



Air Conditioning & Heating

DSXC18

SPLIT SYSTEM AIR CONDITIONER

UP TO 18 SEER

COOLING CAPACITY:

34,000 - 56,000 BTU/H



Contents

Nomenclature	2
Product Specifications	3
Expanded Cooling Data	4
AHRI Ratings.....	16
Dimensions	26
Wiring Diagram.....	27
Accessories	28

Standard Features

- R-410A chlorine-free refrigerant
- Two-Stage Copeland® UltraTech™ scroll compressor
- High-density foam compressor sound blanket
- ComfortNet™ Communications System compatible
- Expanded ComfortAlert™ diagnostics built in
- Set-up capable with 2 low-voltage wires to outdoor unit
- Diagnostic indicator lights and storage of 6 fault codes
- Color-coded terminal strip for non-communicating set-up
- High- and low-pressure switches
- Factory-installed filter drier
- Coil and ambient temperature sensors
- Two-speed, super-quiet condenser fan motor
- Sweat connection service valves with easy access to gauge ports
- AHRI Certified; ETL Listed

Cabinet Features

- Goodman® brand sound control top design
- Wire fan discharge grille
- Steel louver coil guard
- Baked-on powder-paint finish with 500-hour salt-spray approval
- Top and side maintenance access
- Single-panel access to controls with space provided for field-installed accessories
- When properly anchored, meets the 2010 Florida Building Code unit integrity requirements for hurricane-type winds (Anchor bracket kits available.)



* Complete warranty details available from your local dealer or at www.goodmanmfg.com. To receive the Lifetime Compressor Limited Warranty (good for as long as you own your home), 10-Year Unit Replacement Limited Warranty and 10-Year Parts Limited Warranty, online registration must be completed within 60 days of installation. Online registration is not required in California or Québec.



NOMENCLATURE

	D	S	X	C	18	036	1	A	A
	1	2	3	4	5,6	7,8,9	10	11	12
Brand D Goodman® Brand									Engineering * Minor Revision
Product Category S Split System									Engineering * Major Revision
Unit Type X Condenser R-410A Z Heat Pump R-410A									Electrical
Communication Feature C ComfortNet 4-wire communications ready									1 208/230 V, 1 Phase, 60 Hz 2 220/240 V, 1 Phase, 50 Hz 3 208/230 V, 3 Phase, 60 Hz 4 460 V, 3 Phase, 60 Hz 5 380/415 V, 3 Phase, 50 Hz
Efficiency 16 16 SEER 18 18 SEER									Nominal Capacity 036 3 Tons 060 5 Tons 048 4 Tons

* Neither used for order entry or inventory management.



SPECIFICATIONS

	DSXC18 0361A	DSXC18 0481A	DSXC18 0601A
COOLING CAPACITY			
Nominal Cooling (BTU/h)	35,000	47,000	57,000
Decibels	71	72	74
COMPRESSOR			
RLA	15.3	21.2	27.1
LRA	83	104	152.9
CONDENSER FAN MOTOR			
Horsepower (RPM)	⅓	⅓	⅓
FLA	2.80	2.80	2.80
REFRIGERATION SYSTEM			
Refrigerant Line Size ¹			
Liquid Line Size ("O.D.)	⅝"	⅝"	⅝"
Suction Line Size ("O.D.)	⅞"	1⅛"	1⅛"
Refrigerant Connection Size			
Liquid Valve Size ("O.D.)	⅝"	⅝"	⅝"
Suction Valve Size ("O.D.)	⅞"	⅞"	⅞"
Valve Connection Type	Sweat	Sweat	Sweat
Refrigerant Charge	184	259	259
Expansion Device	TXV	TXV	TXV
Superheat at Service Valve	7-9°F	7-9°F	7-9°F
Subcooling at Service Valve	5-7°F	5-7°F	5-7°F
ELECTRICAL DATA			
Voltage-Phase-Hz	208/230-1-60	208/230-1-60	208/230-1-60
Minimum Circuit Ampacity ¹	21.9	29.3	36.7
Max. Overcurrent Protection ²	35	50	60
Min / Max Volts	197 / 253	197 / 253	197 / 253
Electrical Conduit Size	½" or ¾"	½" or ¾"	½" or ¾"
EQUIPMENT WEIGHT (LBS)	206	268	274
SHIP WEIGHT (LBS)	228	290	296

¹ Wire size should be determined in accordance with National Electrical Codes; extensive wire runs will require larger wire sizes

² Must use time-delay fuses or HACR-type circuit breakers of the same size as noted.

NOTES

- Always check the S&R plate for electrical data on the unit being installed.
- Installer will need to supply ⅞" to 1⅛" adapters for suction line connections.
- Unit is charged with refrigerant for 15' of ⅝" liquid line. System charge must be adjusted per Installation Instructions Final Charge Procedure.
- Installation of these units that require a TXV Kit to be installed on the indoor coil.
- PLEASE NOTE: the specified TXV is determined by the outdoor unit, not the indoor coil.

COOLING DATA — DSXC180361A* / CA*F4961*6** +TXV / MBVC2000** -1 LOW STAGE

IDB	AIRFLOW	OUTDOOR AMBIENT TEMPERATURE												ENTERING INDOOR WET BULB TEMPERATURE											
		65°F				75°F				85°F				95°F				105°F				115°F			
		59	63	67	71	59	63	67	71	59	63	67	71	59	63	67	71	59	63	67	71	59	63	67	71
70	MBh	25.3	26.2	28.8	-	24.7	25.6	28.1	-	24.1	25.0	27.4	-	23.6	24.4	26.8	-	22.4	23.2	25.4	-	20.7	21.5	23.5	-
	S/T	0.76	0.63	0.44	-	0.79	0.66	0.45	-	0.81	0.67	0.47	-	0.83	0.70	0.48	-	0.86	0.72	0.50	-	0.87	0.73	0.50	-
	ΔT	19	16	12	-	19	17	13	-	19	17	13	-	19	17	13	-	19	17	13	-	18	15	12	-
	kW	1.30	1.33	1.38	-	1.41	1.45	1.50	-	1.51	1.55	1.60	-	1.60	1.63	1.69	-	1.67	1.71	1.77	-	1.73	1.77	1.84	-
	Amps	5.3	5.5	5.7	-	5.8	5.9	6.1	-	6.3	6.5	6.7	-	6.7	6.9	7.1	-	7.2	7.4	7.6	-	7.6	7.8	8.1	-
	HI PR	210	226	229	-	237	255	259	-	270	290	295	-	308	331	335	-	332	357	362	-	394	423	429	-
	Lo PR	124	128	140	-	128	132	144	-	132	136	149	-	135	140	153	-	138	143	156	-	142	146	159	-
	MBh	24.6	25.5	27.9	-	24.0	24.9	27.3	-	23.4	24.3	26.6	-	22.9	23.7	26.0	-	21.7	22.5	24.7	-	20.1	20.9	22.9	-
	S/T	0.72	0.60	0.42	-	0.75	0.63	0.43	-	0.77	0.64	0.44	-	0.79	0.66	0.46	-	0.82	0.69	0.48	-	0.83	0.69	0.48	-
	ΔT	20	17	13	-	20	17	13	-	20	17	13	-	20	18	13	-	20	17	13	-	19	16	12	-
kW	1.29	1.32	1.37	-	1.40	1.43	1.48	-	1.50	1.53	1.59	-	1.58	1.62	1.68	-	1.65	1.69	1.75	-	1.72	1.76	1.82	-	
Amps	5.3	5.4	5.6	-	5.7	5.9	6.1	-	6.2	6.4	6.6	-	6.7	6.8	7.1	-	7.1	7.3	7.5	-	7.6	7.7	8.0	-	
HI PR	208	224	227	-	235	253	256	-	267	288	292	-	305	327	332	-	329	354	359	-	390	419	425	-	
Lo PR	123	127	138	-	126	130	142	-	131	135	147	-	134	138	151	-	137	141	154	-	140	145	158	-	
MBh	22.7	23.5	25.8	-	22.2	23.0	25.2	-	21.6	22.4	24.6	-	21.1	21.9	24.0	-	20.1	20.8	22.8	-	18.6	19.3	21.1	-	
S/T	0.70	0.58	0.40	-	0.72	0.60	0.42	-	0.74	0.62	0.43	-	0.77	0.64	0.44	-	0.79	0.66	0.46	-	0.80	0.67	0.46	-	
ΔT	20	18	13	-	20	18	13	-	20	18	13	-	21	18	14	-	20	18	13	-	19	16	12	-	
kW	1.28	1.31	1.36	-	1.39	1.42	1.47	-	1.48	1.52	1.57	-	1.57	1.60	1.66	-	1.64	1.68	1.74	-	1.70	1.74	1.80	-	
Amps	5.2	5.4	5.5	-	5.7	5.8	6.0	-	6.2	6.3	6.5	-	6.6	6.8	7.0	-	7.1	7.2	7.5	-	7.5	7.7	7.9	-	
HI PR	206	221	225	-	233	250	254	-	265	285	289	-	302	324	329	-	326	350	355	-	386	415	421	-	
Lo PR	122	125	137	-	125	129	141	-	129	133	146	-	133	137	150	-	135	140	153	-	139	143	156	-	

75	MBh	25.8	26.5	28.7	30.8	25.2	25.9	28.0	30.1	24.6	25.3	27.4	29.4	24.0	24.7	26.7	28.7	22.8	23.4	25.4	27.2	21.1	21.7	23.5	25.2
	S/T	0.86	0.77	0.58	0.38	0.89	0.80	0.60	0.39	0.92	0.82	0.62	0.40	0.95	0.85	0.64	0.41	0.98	0.88	0.66	0.43	0.99	0.89	0.67	0.43
	ΔT	22	20	17	11	22	20	17	12	22	20	17	12	22	21	17	12	22	20	17	12	21	19	16	11
	kW	1.30	1.33	1.38	1.43	1.41	1.45	1.50	1.55	1.51	1.55	1.60	1.66	1.60	1.63	1.69	1.75	1.67	1.71	1.77	1.83	1.73	1.77	1.84	1.90
	Amps	5.3	5.5	5.7	5.9	5.8	5.9	6.1	6.4	6.3	6.5	6.7	6.9	6.7	6.9	7.1	7.4	7.2	7.4	7.6	7.9	7.6	7.8	8.1	8.4
	HI PR	210	226	229	234	237	255	259	265	270	290	295	301	308	331	335	343	332	357	362	370	394	423	429	439
	Lo PR	124	128	140	149	128	132	144	153	132	136	149	158	135	140	153	162	138	143	156	166	142	146	159	170
	MBh	25.0	25.7	27.9	29.9	24.4	25.1	27.2	29.2	23.8	24.5	26.6	28.5	23.3	23.9	25.9	27.8	22.1	22.8	24.6	26.4	20.5	21.1	22.8	24.5
	S/T	0.82	0.74	0.56	0.36	0.85	0.76	0.58	0.37	0.87	0.78	0.59	0.38	0.90	0.81	0.61	0.39	0.94	0.84	0.63	0.41	0.94	0.84	0.64	0.41
	ΔT	23	21	17	12	23	21	17	12	23	21	18	12	23	22	18	12	23	21	17	12	22	20	16	11
kW	1.29	1.32	1.37	1.42	1.40	1.43	1.48	1.54	1.50	1.53	1.59	1.64	1.58	1.62	1.68	1.74	1.65	1.69	1.75	1.82	1.72	1.76	1.82	1.88	
Amps	5.3	5.4	5.6	5.8	5.7	5.9	6.1	6.3	6.2	6.4	6.6	6.9	6.7	6.8	7.1	7.4	7.1	7.3	7.5	7.8	7.6	7.7	8.0	8.3	
HI PR	208	224	227	232	235	253	256	262	267	288	292	298	305	327	332	339	329	354	359	367	390	419	425	435	
Lo PR	123	127	138	147	126	130	142	152	131	135	147	157	134	138	151	161	137	141	154	164	140	145	158	168	
MBh	23.1	23.8	25.7	27.6	22.5	23.2	25.1	27.0	22.0	22.7	24.5	26.3	21.5	22.1	23.9	25.7	20.4	21.0	22.7	24.4	18.9	19.5	21.1	22.6	
S/T	0.79	0.71	0.54	0.35	0.82	0.74	0.56	0.36	0.84	0.75	0.57	0.37	0.87	0.78	0.59	0.38	0.90	0.81	0.61	0.39	0.91	0.81	0.62	0.40	
ΔT	23	22	18	12	24	22	18	12	24	22	18	12	24	22	18	12	24	22	18	12	22	20	17	11	
kW	1.28	1.31	1.36	1.40	1.39	1.42	1.47	1.52	1.48	1.52	1.57	1.63	1.57	1.60	1.66	1.72	1.64	1.68	1.74	1.80	1.70	1.74	1.80	1.87	
Amps	5.2	5.4	5.5	5.8	5.7	5.8	6.0	6.2	6.2	6.3	6.5	6.8	6.6	6.8	7.0	7.3	7.1	7.2	7.5	7.8	7.5	7.7	7.9	8.2	
HI PR	206	221	225	230	233	250	254	259	265	285	289	295	302	324	329	336	326	350	355	363	386	415	421	430	
Lo PR	122	125	137	146	125	129	141	150	129	133	146	155	133	137	150	159	135	140	153	162	139	143	156	166	

IDB = Entering Indoor Dry Bulb Temperature
 High and low pressures are measured at the liquid and suction service valves.
 Shaded area reflects ACCA (TVA) conditions
 kW = Total system power
 Amps = outdoor unit amps (comp. + fan)

COOLING DATA — DSXC180361A* / CA*F4961*6**+TXV / MBVC2000**-1 Low Stage (CONT.)

IDB	AIRFLOW	OUTDOOR AMBIENT TEMPERATURE												ENTERING INDOOR WET BULB TEMPERATURE											
		65°F				75°F				85°F				95°F				105°F				115°F			
		59	63	67	71	59	63	67	71	59	63	67	71	59	63	67	71	59	63	67	71	59	63	67	71
80	MBh	26.2	26.8	28.6	30.6	25.6	26.2	28.0	29.9	25.0	25.5	27.3	29.2	24.4	24.9	26.6	28.5	23.2	23.7	25.3	27.0	21.5	21.9	23.4	25.0
	S/T	0.95	0.89	0.72	0.54	1.00	0.92	0.75	0.56	1.00	0.94	0.77	0.57	1.00	1.00	0.79	0.59	1.00	1.00	0.82	0.61	1.00	1.00	0.83	0.62
	ΔT	25	23	20	16	25	24	21	17	25	24	21	17	24	25	21	17	23	23	21	16	21	22	19	15
	kW	1.30	1.33	1.38	1.43	1.41	1.45	1.50	1.55	1.51	1.55	1.60	1.66	1.60	1.63	1.69	1.75	1.67	1.71	1.77	1.83	1.73	1.77	1.84	1.90
	Amps	5.3	5.5	5.7	5.9	5.8	5.9	6.1	6.4	6.3	6.5	6.7	6.9	6.7	6.9	7.1	7.4	7.2	7.4	7.6	7.9	7.6	7.8	8.1	8.4
	HI PR	210	226	229	234	237	255	259	265	270	290	295	301	308	331	335	343	332	357	362	370	394	423	429	439
	Lo PR	124	128	140	149	128	132	144	153	132	136	149	158	135	140	153	162	138	143	156	166	142	146	159	170
	MBh	25.4	26.0	27.8	29.7	24.9	25.4	27.1	29.0	24.3	24.8	26.5	28.3	23.7	24.2	25.8	27.6	22.5	23.0	24.6	26.2	20.8	21.3	22.7	24.3
	S/T	0.90	0.85	0.69	0.51	0.93	0.88	0.71	0.53	0.96	0.90	0.73	0.55	0.99	0.93	0.76	0.56	1.00	0.96	0.78	0.59	1.00	0.97	0.79	0.59
	ΔT	26	25	21	17	26	25	22	17	26	25	22	17	26	25	22	17	25	25	21	17	23	23	20	16
kW	1.29	1.32	1.37	1.42	1.40	1.43	1.48	1.54	1.50	1.53	1.59	1.64	1.58	1.62	1.68	1.74	1.65	1.69	1.75	1.82	1.72	1.76	1.82	1.88	
Amps	5.3	5.4	5.6	5.8	5.7	5.9	6.1	6.3	6.2	6.4	6.6	6.9	6.7	6.8	7.1	7.4	7.1	7.3	7.5	7.8	7.6	7.7	8.0	8.3	
HI PR	208	224	227	232	235	253	256	262	267	288	292	298	305	327	332	339	329	354	359	367	390	419	425	435	
Lo PR	123	127	138	147	126	130	142	152	131	135	147	157	134	138	151	161	137	141	154	164	140	145	158	168	
MBh	23.5	24.0	25.6	27.4	22.9	23.4	25.0	26.8	22.4	22.9	24.5	26.1	21.9	22.3	23.9	25.5	20.8	21.2	22.7	24.2	19.2	19.6	21.0	22.4	
S/T	0.87	0.82	0.66	0.50	0.90	0.85	0.69	0.51	0.92	0.87	0.71	0.53	0.95	0.89	0.73	0.54	0.99	0.93	0.76	0.56	1.00	0.94	0.76	0.57	
ΔT	26	25	22	17	26	25	22	18	26	25	22	18	27	26	22	18	26	25	22	17	25	24	20	16	
kW	1.28	1.31	1.36	1.40	1.39	1.42	1.47	1.52	1.48	1.52	1.57	1.63	1.57	1.60	1.66	1.72	1.64	1.68	1.74	1.80	1.70	1.74	1.80	1.87	
Amps	5.2	5.4	5.5	5.8	5.7	5.8	6.0	6.2	6.2	6.3	6.5	6.8	6.6	6.8	7.0	7.3	7.1	7.2	7.5	7.8	7.5	7.7	7.9	8.2	
HI PR	206	221	225	230	233	250	254	259	265	285	289	295	302	324	329	336	326	350	355	363	386	415	421	430	
Lo PR	122	125	137	146	125	129	141	150	129	133	146	155	133	137	150	159	135	140	153	162	139	143	156	166	
85	MBh	26.7	27.2	28.5	30.4	26.0	26.6	27.8	29.7	25.4	25.9	27.1	29.0	24.8	25.3	26.5	28.3	23.6	24.0	25.2	26.8	21.8	22.3	23.3	24.9
	S/T	0.99	0.96	0.86	0.70	1.00	0.99	0.89	0.73	1.00	1.00	0.92	0.74	1.00	1.00	0.95	0.77	1.00	1.00	0.98	0.80	1.00	1.00	0.99	0.80
	ΔT	26	26	24	21	26	26	25	21	25	26	25	21	25	25	25	21	23	24	24	21	22	22	23	20
	kW	1.30	1.33	1.38	1.43	1.41	1.45	1.50	1.55	1.51	1.55	1.60	1.66	1.60	1.63	1.69	1.75	1.67	1.71	1.77	1.83	1.73	1.77	1.84	1.90
	Amps	5.3	5.5	5.7	5.9	5.8	5.9	6.1	6.4	6.3	6.5	6.7	6.9	6.7	6.9	7.1	7.4	7.2	7.4	7.6	7.9	7.6	7.8	8.1	8.4
	HI PR	210	226	229	234	237	255	259	265	270	290	295	301	308	331	335	343	332	357	362	370	394	423	429	439
	Lo PR	124	128	140	149	128	132	144	153	132	136	149	158	135	140	153	162	138	143	156	166	142	146	159	170
	MBh	25.9	26.4	27.6	29.5	25.3	25.8	27.0	28.8	24.7	25.2	26.4	28.1	24.1	24.6	25.7	27.4	22.9	23.3	24.4	26.1	21.2	21.6	22.6	24.1
	S/T	0.95	0.91	0.82	0.67	0.98	0.95	0.85	0.69	1.00	0.97	0.88	0.71	1.00	1.00	0.90	0.73	1.00	1.00	0.94	0.76	1.00	1.00	0.95	0.77
	ΔT	27	27	25	22	28	27	26	22	28	27	26	22	27	27	26	22	25	26	26	22	24	24	24	21
kW	1.29	1.32	1.37	1.42	1.40	1.43	1.48	1.54	1.50	1.53	1.59	1.64	1.58	1.62	1.68	1.74	1.65	1.69	1.75	1.82	1.72	1.76	1.82	1.88	
Amps	5.3	5.4	5.6	5.8	5.7	5.9	6.1	6.3	6.2	6.4	6.6	6.9	6.7	6.8	7.1	7.4	7.1	7.3	7.5	7.8	7.6	7.7	8.0	8.3	
HI PR	208	224	227	232	235	253	256	262	267	288	292	298	305	327	332	339	329	354	359	367	390	419	425	435	
Lo PR	123	127	138	147	126	130	142	152	131	135	147	157	134	138	151	161	137	141	154	164	140	145	158	168	
MBh	23.9	24.4	25.5	27.2	23.3	23.8	24.9	26.6	22.8	23.2	24.3	26.0	22.2	22.7	23.7	25.3	21.1	21.5	22.5	24.1	19.6	19.9	20.9	22.3	
S/T	0.91	0.88	0.79	0.64	0.94	0.91	0.82	0.67	0.97	0.93	0.84	0.68	1.00	0.97	0.87	0.71	1.00	1.00	0.90	0.73	1.00	1.00	0.91	0.74	
ΔT	27.8	27	26	22	28	28	26	23	28	28	26	23	28	28	26	23	27	27	26	23	25	25	24	21	
kW	1.28	1.31	1.36	1.40	1.39	1.42	1.47	1.52	1.48	1.52	1.57	1.63	1.57	1.60	1.66	1.72	1.64	1.68	1.74	1.80	1.70	1.74	1.80	1.87	
Amps	5.2	5.4	5.5	5.8	5.7	5.8	6.0	6.2	6.2	6.3	6.5	6.8	6.6	6.8	7.0	7.3	7.1	7.2	7.5	7.8	7.5	7.7	7.9	8.2	
HI PR	206	221	225	230	233	250	254	259	265	285	289	295	302	324	329	336	326	350	355	363	386	415	421	430	
Lo PR	122	125	137	146	125	129	141	150	129	133	146	155	133	137	150	159	135	140	153	162	139	143	156	166	

kW = Total system power
Amps = outdoor unit amps (comp. fan)

Shaded area reflects AHRI (TIVA) conditions

IDB = Entering Indoor Dry Bulb Temperature
High and low pressures are measured at the liquid and suction service valves.

COOLING DATA — DSXC180361A* / CA*F4961*6** +TXV / MBVC2000** -1 HIGH STAGE

IDB	AIRFLOW	OUTDOOR AMBIENT TEMPERATURE												ENTERING INDOOR WET BULB TEMPERATURE											
		65°F				75°F				85°F				95°F				105°F				115°F			
		59	63	67	71	59	63	67	71	59	63	67	71	59	63	67	71	59	63	67	71	59	63	67	71
70	MBh	36.7	38.1	41.7	-	35.9	37.2	40.7	-	35.0	36.3	39.8	-	34.2	35.4	38.8	-	32.4	33.6	36.8	-	30.1	31.2	34.1	-
	S/T	0.74	0.62	0.43	-	0.76	0.64	0.44	-	0.78	0.65	0.45	-	0.81	0.68	0.47	-	0.84	0.70	0.49	-	0.85	0.71	0.49	-
	ΔT	19	16	12	-	19	16	12	-	19	16	12	-	19	17	13	-	19	16	12	-	18	15	12	-
	kW	2.09	2.14	2.21	-	2.26	2.31	2.39	-	2.41	2.47	2.56	-	2.55	2.61	2.70	-	2.66	2.73	2.82	-	2.76	2.83	2.93	-
	Amps	8.2	8.4	8.7	-	8.9	9.1	9.4	-	9.7	9.9	10.3	-	10.4	10.7	11.0	-	11.1	11.4	11.8	-	11.8	12.1	12.5	-
	HI PR	220	237	240	-	249	268	271	-	283	304	309	-	322	347	352	-	348	374	380	-	413	444	450	-
	Lo PR	118	122	133	-	122	126	137	-	126	130	142	-	129	134	146	-	132	136	149	-	135	140	152	-
	MBh	35.6	36.9	40.5	-	34.8	36.1	39.5	-	34.0	35.2	38.6	-	33.2	34.4	37.7	-	31.5	32.7	35.8	-	29.2	30.2	33.1	-
	S/T	0.70	0.59	0.41	-	0.73	0.61	0.42	-	0.75	0.62	0.43	-	0.77	0.64	0.45	-	0.80	0.67	0.46	-	0.81	0.67	0.47	-
	ΔT	20	17	13	-	20	17	13	-	20	17	13	-	20	17	13	-	20	17	13	-	18	16	12	-
kW	2.07	2.12	2.19	-	2.24	2.29	2.37	-	2.39	2.45	2.53	-	2.53	2.59	2.68	-	2.64	2.70	2.80	-	2.74	2.80	2.90	-	
Amps	8.1	8.3	8.6	-	8.8	9.0	9.3	-	9.6	9.9	10.2	-	10.3	10.6	10.9	-	11.0	11.3	11.7	-	11.7	12.0	12.4	-	
HI PR	218	234	238	-	246	265	269	-	280	301	306	-	319	343	348	-	345	371	376	-	409	439	446	-	
Lo PR	117	121	132	-	121	125	136	-	125	129	141	-	128	132	144	-	131	135	147	-	134	138	151	-	
MBh	32.9	34.1	37.4	-	32.1	33.3	36.5	-	31.4	32.5	35.6	-	30.6	31.7	34.8	-	29.1	30.1	33.0	-	26.9	27.9	30.6	-	
S/T	0.68	0.57	0.39	-	0.70	0.59	0.41	-	0.72	0.60	0.42	-	0.74	0.62	0.43	-	0.77	0.65	0.45	-	0.78	0.65	0.45	-	
ΔT	20	17	13	-	20	18	13	-	20	18	13	-	20	18	13	-	20	17	13	-	19	16	12	-	
kW	2.05	2.10	2.17	-	2.22	2.27	2.35	-	2.37	2.43	2.51	-	2.50	2.56	2.65	-	2.62	2.68	2.77	-	2.71	2.78	2.88	-	
Amps	8.1	8.3	8.5	-	8.7	9.0	9.3	-	9.5	9.8	10.1	-	10.2	10.5	10.8	-	10.9	11.2	11.5	-	11.6	11.8	12.3	-	
HI PR	216	232	235	-	244	262	266	-	278	298	303	-	316	340	345	-	341	367	372	-	405	435	441	-	
Lo PR	116	120	131	-	120	123	135	-	124	127	139	-	127	131	143	-	129	134	146	-	133	137	149	-	
75	MBh	37.3	38.4	41.6	44.7	36.5	37.5	40.6	43.6	35.6	36.7	39.7	42.6	34.7	35.8	38.7	41.5	33.0	34.0	36.8	39.5	30.6	31.5	34.1	36.6
	S/T	0.84	0.75	0.57	0.37	0.87	0.78	0.59	0.38	0.89	0.80	0.60	0.39	0.92	0.82	0.62	0.40	0.95	0.85	0.65	0.42	0.96	0.86	0.65	0.42
	ΔT	22	20	16	11	22	20	17	11	22	20	17	11	22	20	17	12	22	20	16	11	20	19	15	11
	kW	2.09	2.14	2.21	2.28	2.26	2.31	2.39	2.48	2.41	2.47	2.56	2.65	2.55	2.61	2.70	2.80	2.66	2.73	2.82	2.92	2.76	2.83	2.93	3.03
	Amps	8.2	8.4	8.7	9.0	8.9	9.1	9.4	9.8	9.7	9.9	10.3	10.7	10.4	10.7	11.0	11.5	11.1	11.4	11.8	12.2	11.8	12.1	12.5	13.0
	HI PR	220	237	240	245	249	268	271	277	283	304	309	316	322	347	352	359	348	374	380	388	413	444	450	460
	Lo PR	118	122	133	142	122	126	137	146	126	130	142	151	129	134	146	155	132	136	149	158	135	140	152	162
	MBh	36.3	37.3	40.4	43.4	35.4	36.5	39.5	42.4	34.6	35.6	38.5	41.3	33.7	34.7	37.6	40.3	32.0	33.0	35.7	38.3	29.7	30.6	33.1	35.5
	S/T	0.80	0.72	0.54	0.35	0.83	0.74	0.56	0.36	0.85	0.76	0.58	0.37	0.88	0.78	0.59	0.38	0.91	0.81	0.62	0.40	0.92	0.82	0.62	0.40
	ΔT	23	21	17	12	23	21	17	12	23	21	17	12	23	21	17	12	23	21	17	12	21	20	16	11
kW	2.07	2.12	2.19	2.26	2.24	2.29	2.37	2.45	2.39	2.45	2.53	2.62	2.53	2.59	2.68	2.77	2.64	2.70	2.80	2.90	2.74	2.80	2.90	3.01	
Amps	8.1	8.3	8.6	9.0	8.8	9.0	9.3	9.7	9.6	9.9	10.2	10.6	10.3	10.6	10.9	11.4	11.0	11.3	11.7	12.1	11.7	12.0	12.4	12.9	
HI PR	218	234	238	243	246	265	269	275	280	301	306	312	319	343	348	356	345	371	376	384	409	439	446	455	
Lo PR	117	121	132	141	121	125	136	145	125	129	141	150	128	132	144	154	131	135	147	157	134	138	151	161	
MBh	33.5	34.5	37.3	40.0	32.7	33.6	36.4	39.1	31.9	32.8	35.6	38.2	31.1	32.0	34.7	37.2	29.6	30.4	33.0	35.4	27.4	28.2	30.5	32.8	
S/T	0.77	0.69	0.52	0.34	0.80	0.71	0.54	0.35	0.82	0.73	0.55	0.36	0.85	0.76	0.57	0.37	0.88	0.79	0.59	0.38	0.89	0.79	0.60	0.39	
ΔT	23	21	17	12	23	22	18	12	23	22	18	12	24	22	18	12	24	21	18	12	22	20	16	11	
kW	2.05	2.10	2.17	2.24	2.22	2.27	2.35	2.43	2.37	2.43	2.51	2.60	2.50	2.56	2.65	2.75	2.62	2.68	2.77	2.87	2.71	2.78	2.88	2.98	
Amps	8.1	8.3	8.5	8.9	8.7	9.0	9.3	9.6	9.5	9.8	10.1	10.5	10.2	10.5	10.8	11.2	10.9	11.2	11.5	12.0	11.6	11.8	12.3	12.7	
HI PR	216	232	235	241	244	262	266	272	278	298	303	309	316	340	345	352	341	367	372	380	405	435	441	451	
Lo PR	116	120	131	139	120	123	135	143	124	127	139	148	127	131	143	152	129	134	146	155	133	137	149	159	

IDB = Entering Indoor Dry Bulb Temperature
 High and low pressures are measured at the liquid and suction service valves.
 Shaded area reflects ACCA (TVA) conditions
 kW = Total system power
 Amps = outdoor unit amps (comp. + fan)

COOLING DATA — DSXC180361A* / CA*F4961**6** +TXV / MBVC2000** -1 HIGH STAGE (CONT.)

IDB	AIRFLOW	OUTDOOR AMBIENT TEMPERATURE												ENTERING INDOOR WET BULB TEMPERATURE											
		65°F				75°F				85°F				95°F				105°F				115°F			
		59	63	67	71	59	63	67	71	59	63	67	71	59	63	67	71	59	63	67	71	59	63	67	71
80	MBh	38.0	38.8	41.5	44.4	37.1	37.9	40.5	43.3	36.2	37.0	39.6	42.3	35.4	36.1	38.6	41.3	33.6	34.3	36.7	39.2	31.1	31.8	34.0	36.3
	S/T	0.92	0.86	0.70	0.52	0.95	0.89	0.73	0.54	1.00	0.92	0.75	0.56	1.00	0.95	0.77	0.58	1.00	1.00	0.80	0.60	1.00	1.00	0.81	0.60
	ΔT	24	23	20	16	24	23	20	16	25	23	20	16	24	24	21	16	24	24	20	16	22	22	19	15
	kW	2.09	2.14	2.21	2.28	2.26	2.31	2.39	2.48	2.41	2.47	2.56	2.65	2.55	2.61	2.70	2.80	2.66	2.73	2.82	2.92	2.76	2.83	2.93	3.03
	Amps	8.2	8.4	8.7	9.0	8.9	9.1	9.4	9.8	9.7	9.9	10.3	10.7	10.4	10.7	11.0	11.5	11.1	11.4	11.8	12.2	11.8	12.1	12.5	13.0
	HI PR	220	237	240	245	249	268	271	277	283	304	309	316	322	347	352	359	348	374	380	388	413	444	450	460
	Lo PR	118	122	133	142	122	126	137	146	126	130	142	151	129	134	146	155	132	136	149	158	135	140	152	162
	MBh	36.9	37.7	40.3	43.1	36.0	36.8	39.3	42.1	35.2	35.9	38.4	41.1	34.3	35.1	37.5	40.1	32.6	33.3	35.6	38.1	30.2	30.9	33.0	35.2
	S/T	0.88	0.82	0.67	0.50	0.91	0.85	0.69	0.52	0.93	0.87	0.71	0.53	0.96	0.90	0.73	0.55	1.00	0.94	0.76	0.57	1.00	0.94	0.77	0.57
	ΔT	25	24	21	17	26	25	21	17	26	25	21	17	26	25	22	17	25	24	21	17	24	23	20	16
	kW	2.07	2.12	2.19	2.26	2.24	2.29	2.37	2.45	2.39	2.45	2.53	2.62	2.53	2.59	2.68	2.77	2.64	2.70	2.80	2.90	2.74	2.80	2.90	3.01
	Amps	8.1	8.3	8.6	9.0	8.8	9.0	9.3	9.7	9.6	9.9	10.2	10.6	10.3	10.6	10.9	11.4	11.0	11.3	11.7	12.1	11.7	12.0	12.4	12.9
HI PR	218	234	238	243	246	265	269	275	280	301	306	312	319	343	348	356	345	371	376	384	409	439	446	455	
Lo PR	117	121	132	141	121	125	136	145	125	129	141	150	128	132	144	154	131	135	147	157	134	138	151	161	
MBh	34.1	34.8	37.2	39.7	33.3	34.0	36.3	38.8	32.5	33.2	35.4	37.9	31.7	32.4	34.6	37.0	30.1	30.8	32.9	35.1	27.9	28.5	30.4	32.5	
S/T	0.85	0.79	0.65	0.48	0.88	0.82	0.67	0.50	0.90	0.84	0.69	0.51	0.93	0.87	0.71	0.53	0.96	0.90	0.74	0.55	0.97	0.91	0.74	0.55	
ΔT	26	25	22	17	26	25	22	17	26	25	22	17	26	25	22	18	26	25	22	17	24	23	20	16	
kW	2.05	2.10	2.17	2.24	2.22	2.27	2.35	2.43	2.37	2.43	2.51	2.60	2.50	2.56	2.65	2.75	2.62	2.68	2.77	2.87	2.71	2.78	2.88	2.98	
Amps	8.1	8.3	8.5	8.9	8.7	9.0	9.3	9.6	9.5	9.8	10.1	10.5	10.2	10.5	10.8	11.2	10.9	11.2	11.5	12.0	11.6	11.8	12.3	12.7	
HI PR	216	232	235	241	244	262	266	272	278	298	303	309	316	340	345	352	341	367	372	380	405	435	441	451	
Lo PR	116	120	131	139	120	123	135	143	124	127	139	148	127	131	143	152	129	134	146	155	133	137	149	159	
85	MBh	38.7	39.4	41.3	44.0	37.8	38.5	40.3	43.0	36.9	37.6	39.4	42.0	36.0	36.7	38.4	41.0	34.2	34.8	36.5	38.9	31.7	32.3	33.8	36.1
	S/T	0.96	0.93	0.84	0.68	1.00	0.96	0.87	0.71	1.00	0.99	0.89	0.72	1.00	1.00	0.92	0.75	1.00	1.00	0.96	0.78	1.00	1.00	0.96	0.78
	ΔT	26	25	24	21	26	26	24	21	25	26	24	21	25	25	24	21	24	24	24	21	22	22	23	19
	kW	2.09	2.14	2.21	2.28	2.26	2.31	2.39	2.48	2.41	2.47	2.56	2.65	2.55	2.61	2.70	2.80	2.66	2.73	2.82	2.92	2.76	2.83	2.93	3.03
	Amps	8.2	8.4	8.7	9.0	8.9	9.1	9.4	9.8	9.7	9.9	10.3	10.7	10.4	10.7	11.0	11.5	11.1	11.4	11.8	12.2	11.8	12.1	12.5	13.0
	HI PR	220	237	240	245	249	268	271	277	283	304	309	316	322	347	352	359	348	374	380	388	413	444	450	460
	Lo PR	118	122	133	142	122	126	137	146	126	130	142	151	129	134	146	155	132	136	149	158	135	140	152	162
	MBh	37.5	38.3	40.1	42.8	36.7	37.4	39.1	41.8	35.8	36.5	38.2	40.8	34.9	35.6	37.3	39.8	33.2	33.8	35.4	37.8	30.7	31.3	32.8	35.0
	S/T	0.92	0.89	0.80	0.65	0.95	0.92	0.83	0.67	0.98	0.94	0.85	0.69	1.00	0.97	0.88	0.71	1.00	1.00	0.91	0.74	1.00	1.00	0.92	0.75
	ΔT	27	27	25	22	27	27	25	22	27	27	25	22	27	27	26	22	26	26	25	22	24	25	24	20
	kW	2.07	2.12	2.19	2.26	2.24	2.29	2.37	2.45	2.39	2.45	2.53	2.62	2.53	2.59	2.68	2.77	2.64	2.70	2.80	2.90	2.74	2.80	2.90	3.01
	Amps	8.1	8.3	8.6	9.0	8.8	9.0	9.3	9.7	9.6	9.9	10.2	10.6	10.3	10.6	10.9	11.4	11.0	11.3	11.7	12.1	11.7	12.0	12.4	12.9
HI PR	218	234	238	243	246	265	269	275	280	301	306	312	319	343	348	356	345	371	376	384	409	439	446	455	
Lo PR	117	121	132	141	121	125	136	145	125	129	141	150	128	132	144	154	131	135	147	157	134	138	151	161	
MBh	34.6	35.3	37.0	39.5	33.8	34.5	36.1	38.5	33.0	33.7	35.3	37.6	32.2	32.9	34.4	36.7	30.6	31.2	32.7	34.9	28.4	28.9	30.3	32.3	
S/T	0.89	0.86	0.77	0.63	0.92	0.89	0.80	0.65	0.94	0.91	0.82	0.67	0.97	0.94	0.85	0.69	1.00	0.97	0.88	0.71	1.00	0.98	0.89	0.72	
ΔT	28	27	26	22	28	27	26	22	28	27	26	22	28	28	26	23	27	27	26	22	25	25	24	21	
kW	2.05	2.10	2.17	2.24	2.22	2.27	2.35	2.43	2.37	2.43	2.51	2.60	2.50	2.56	2.65	2.75	2.62	2.68	2.77	2.87	2.71	2.78	2.88	2.98	
Amps	8.1	8.3	8.5	8.9	8.7	9.0	9.3	9.6	9.5	9.8	10.1	10.5	10.2	10.5	10.8	11.2	10.9	11.2	11.5	12.0	11.6	11.8	12.3	12.7	
HI PR	216	232	235	241	244	262	266	272	278	298	303	309	316	340	345	352	341	367	372	380	405	435	441	451	
Lo PR	116	120	131	139	120	123	135	143	124	127	139	148	127	131	143	152	129	134	146	155	133	137	149	159	

IDB = Entering Indoor Dry Bulb Temperature
 High and low pressures are measured at the liquid and suction service valves.
 Shaded area reflects AHRI (TVA) conditions
 kW = Total system power
 Amps = outdoor unit amps (comp. + fan)

COOLING DATA — DSXC180481A* / CA*F4961*6** +TXV / MBVC2000** -1 Low Stage

IDB	AIRFLOW	OUTDOOR AMBIENT TEMPERATURE																								
		65°F				75°F				85°F				95°F				105°F				115°F				
		59	63	67	71	59	63	67	71	59	63	67	71	59	63	67	71	59	63	67	71	59	63	67	71	
70	1325	MBh	34.6	35.8	39.3	-	33.8	35.0	38.3	-	33.0	34.2	37.4	-	32.2	33.3	36.5	-	30.5	31.7	34.7	-	28.3	29.3	32.1	-
		S/T	0.76	0.64	0.44	-	0.79	0.66	0.46	-	0.81	0.68	0.47	-	0.83	0.70	0.48	-	0.87	0.72	0.50	-	0.87	0.73	0.51	-
		ΔT	18	16	12	-	18	16	12	-	18	16	12	-	19	16	12	-	18	16	12	-	17	15	11	-
		kW	1.87	1.91	1.97	-	2.02	2.07	2.14	-	2.16	2.21	2.29	-	2.28	2.34	2.42	-	2.39	2.44	2.53	-	2.47	2.53	2.62	-
	1175	Amps	7.2	7.4	7.6	-	7.8	8.0	8.3	-	8.5	8.7	9.0	-	9.1	9.4	9.7	-	9.7	10.0	10.3	-	10.4	10.6	11.0	-
		HI PR	216	232	235	-	244	262	266	-	277	298	303	-	316	340	345	-	356	382	388	-	398	428	434	-
		Lo PR	121	125	137	-	125	129	141	-	129	133	146	-	133	137	149	-	135	140	152	-	139	143	156	-
		MBh	33.6	34.8	38.1	-	32.8	34.0	37.2	-	32.0	33.2	36.3	-	31.2	32.4	35.5	-	29.7	30.7	33.7	-	27.5	28.5	31.2	-
	1025	S/T	0.73	0.61	0.42	-	0.75	0.63	0.44	-	0.77	0.64	0.45	-	0.80	0.66	0.46	-	0.83	0.69	0.48	-	0.83	0.70	0.48	-
		ΔT	19	16	13	-	19	17	13	-	19	17	13	-	19	17	13	-	19	17	13	-	18	16	12	-
		kW	1.85	1.89	1.96	-	2.00	2.05	2.12	-	2.14	2.19	2.27	-	2.26	2.32	2.40	-	2.36	2.42	2.51	-	2.45	2.51	2.60	-
		Amps	7.1	7.3	7.6	-	7.7	7.9	8.2	-	8.4	8.7	9.0	-	9.0	9.3	9.6	-	9.7	9.9	10.2	-	10.3	10.5	10.9	-
1025	HI PR	214	230	233	-	242	260	263	-	275	295	300	-	313	336	341	-	352	378	384	-	394	424	430	-	
	Lo PR	120	124	135	-	124	128	139	-	128	132	144	-	131	136	148	-	134	138	151	-	137	142	155	-	
	MBh	31.0	32.1	35.2	-	30.3	31.4	34.4	-	29.5	30.6	33.5	-	28.8	29.9	32.7	-	27.4	28.4	31.1	-	25.4	26.3	28.8	-	
	S/T	0.70	0.58	0.40	-	0.73	0.61	0.42	-	0.74	0.62	0.43	-	0.77	0.64	0.44	-	0.80	0.67	0.46	-	0.80	0.67	0.46	-	
1025	ΔT	19	17	13	-	20	17	13	-	20	17	13	-	20	17	13	-	20	17	13	-	18	16	12	-	
	kW	1.83	1.88	1.94	-	1.99	2.03	2.10	-	2.12	2.17	2.25	-	2.24	2.29	2.38	-	2.34	2.40	2.48	-	2.43	2.49	2.58	-	
	Amps	7.1	7.2	7.5	-	7.7	7.9	8.1	-	8.4	8.6	8.9	-	9.0	9.2	9.5	-	9.6	9.8	10.1	-	10.2	10.4	10.8	-	
	HI PR	212	227	231	-	239	257	261	-	272	292	297	-	310	333	338	-	348	375	380	-	390	420	426	-	
1025	Lo PR	119	123	134	-	123	126	138	-	127	131	143	-	130	134	147	-	133	137	149	-	136	140	153	-	

75	1325	MBh	35.2	36.2	39.2	42.0	34.3	35.4	38.3	41.1	33.5	34.5	37.4	40.1	32.7	33.7	36.4	39.1	31.1	32.0	34.6	37.2	28.8	29.6	32.1	34.4
		S/T	0.86	0.77	0.59	0.38	0.90	0.80	0.61	0.39	0.92	0.82	0.62	0.40	0.95	0.85	0.64	0.41	0.98	0.88	0.67	0.43	0.99	0.89	0.67	0.43
		ΔT	21	19	16	11	21	20	16	11	21	20	16	11	22	20	16	11	21	20	16	11	20	18	15	10
		kW	1.87	1.91	1.97	2.04	2.02	2.07	2.14	2.22	2.16	2.21	2.29	2.37	2.28	2.34	2.42	2.51	2.39	2.44	2.53	2.62	2.47	2.53	2.62	2.72
	1175	Amps	7.2	7.4	7.6	7.9	7.8	8.0	8.3	8.6	8.5	8.7	9.0	9.4	9.1	9.4	9.7	10.1	9.7	10.0	10.3	10.8	10.4	10.6	11.0	11.4
		HI PR	216	232	235	241	244	262	266	272	277	298	303	309	316	340	345	352	356	382	388	396	398	428	434	444
		Lo PR	121	125	137	146	125	129	141	150	129	133	146	155	133	137	149	159	135	140	152	162	139	143	156	166
		MBh	34.1	35.1	38.0	40.8	33.3	34.3	37.2	39.9	32.5	33.5	36.3	38.9	31.7	32.7	35.4	38.0	30.2	31.1	33.6	36.1	27.9	28.8	31.1	33.4
	1025	S/T	0.82	0.74	0.56	0.36	0.85	0.76	0.58	0.37	0.88	0.78	0.59	0.38	0.90	0.81	0.61	0.39	0.94	0.84	0.64	0.41	0.95	0.85	0.64	0.41
		ΔT	22	20	17	11	22	21	17	12	22	21	17	12	22	21	17	12	22	20	17	12	21	19	16	11
		kW	1.85	1.89	1.96	2.03	2.00	2.05	2.12	2.20	2.14	2.19	2.27	2.35	2.26	2.32	2.40	2.48	2.36	2.42	2.51	2.60	2.45	2.51	2.60	2.69
		Amps	7.1	7.3	7.6	7.9	7.7	7.9	8.2	8.5	8.4	8.7	9.0	9.3	9.0	9.3	9.6	10.0	9.7	9.9	10.2	10.6	10.3	10.5	10.9	11.3
1025	HI PR	214	230	233	238	242	260	263	269	275	295	300	306	313	336	341	349	352	378	384	392	394	424	430	439	
	Lo PR	120	124	135	144	124	128	139	148	128	132	144	154	131	136	148	158	134	138	151	161	137	142	155	165	
	MBh	31.5	32.4	35.1	37.7	30.8	31.7	34.3	36.8	30.0	30.9	33.5	35.9	29.3	30.2	32.7	35.1	27.8	28.7	31.0	33.3	25.8	26.6	28.7	30.8	
	S/T	0.80	0.71	0.54	0.35	0.82	0.74	0.56	0.36	0.85	0.76	0.57	0.37	0.87	0.78	0.59	0.38	0.91	0.81	0.61	0.39	0.91	0.82	0.62	0.40	
1025	ΔT	22	21	17	12	23	21	17	12	23	21	17	12	23	21	17	12	23	21	17	12	21	19	16	11	
	kW	1.83	1.88	1.94	2.01	1.99	2.03	2.10	2.18	2.12	2.17	2.25	2.33	2.24	2.29	2.38	2.46	2.34	2.40	2.48	2.57	2.43	2.49	2.58	2.67	
	Amps	7.1	7.2	7.5	7.8	7.7	7.9	8.1	8.4	8.4	8.6	8.9	9.2	9.0	9.2	9.5	9.9	9.6	9.8	10.1	10.5	10.2	10.4	10.8	11.2	
	HI PR	212	227	231	236	239	257	261	267	272	292	297	303	310	333	338	345	348	375	380	388	390	420	426	435	
1025	Lo PR	119	123	134	143	123	126	138	147	127	131	143	152	130	134	147	156	133	137	149	159	136	140	153	163	

IDB = Entering Indoor Dry Bulb Temperature
 High and low pressures are measured at the liquid and suction service valves.
 Shaded area reflects ACCA (TVA) conditions
 kW = Total system power
 Amps = outdoor unit amps (comp.+fan)

COOLING DATA — DSXC180481A* / CA*F4961*6** +TXV / MBVC2000** -1 Low Stage (CONT.)

IDB	AIRFLOW	OUTDOOR AMBIENT TEMPERATURE												ENTERING INDOOR WET BULB TEMPERATURE											
		65°F				75°F				85°F				95°F				105°F				115°F			
		59	63	67	71	59	63	67	71	59	63	67	71	59	63	67	71	59	63	67	71	59	63	67	71
80	MBh	35.8	36.6	39.1	41.8	34.9	35.7	38.2	40.8	34.1	34.9	37.2	39.8	33.3	34.0	36.3	38.8	31.6	32.3	34.5	36.9	29.3	29.9	32.0	34.2
	S/T	0.95	0.89	0.72	0.54	1.00	0.92	0.75	0.56	1.00	0.95	0.77	0.58	1.00	1.00	0.79	0.59	1.00	1.00	0.82	0.62	1.00	1.00	0.83	0.62
	ΔT	24	23	20	16	24	23	20	16	24	23	20	16	23	24	20	16	22	24	20	16	20	21	18	15
	1325 kW	1.87	1.91	1.97	2.04	2.02	2.07	2.14	2.22	2.16	2.21	2.29	2.37	2.28	2.34	2.42	2.51	2.39	2.44	2.53	2.62	2.47	2.53	2.62	2.72
	Amps	7.2	7.4	7.6	7.9	7.8	8.0	8.3	8.6	8.5	8.7	9.0	9.4	9.1	9.4	9.7	10.1	9.7	10.0	10.3	10.8	10.4	10.6	11.0	11.4
	Hi PR	216	232	235	241	244	262	266	272	277	298	303	309	316	340	345	352	356	382	388	396	398	428	434	444
	Lo PR	121	125	137	146	125	129	141	150	129	133	146	155	133	137	149	159	135	140	152	162	139	143	156	166
	MBh	34.7	35.5	37.9	40.5	33.9	34.7	37.0	39.6	33.1	33.8	36.2	38.7	32.3	33.0	35.3	37.7	30.7	31.4	33.5	35.8	28.4	29.1	31.0	33.2
	S/T	0.90	0.85	0.69	0.52	0.94	0.88	0.72	0.53	0.96	0.90	0.73	0.55	0.99	0.93	0.76	0.57	1.00	0.97	0.79	0.59	1.00	0.97	0.79	0.59
	ΔT	25	24	20	16	25	24	21	17	25	24	21	17	25	24	21	17	24	24	21	16	22	22	19	15
1175 kW	1.85	1.89	1.96	2.03	2.00	2.05	2.12	2.20	2.14	2.19	2.27	2.35	2.26	2.32	2.40	2.48	2.36	2.42	2.51	2.60	2.45	2.51	2.60	2.69	
Amps	7.1	7.3	7.6	7.9	7.7	7.9	8.2	8.5	8.4	8.7	9.0	9.3	9.0	9.3	9.6	10.0	9.7	9.9	10.2	10.6	10.3	10.5	10.9	11.3	
Hi PR	214	230	233	238	242	260	263	269	275	295	300	306	313	336	341	349	352	378	384	392	394	424	430	439	
Lo PR	120	124	135	144	124	128	139	148	128	132	144	154	131	136	148	158	134	138	151	161	137	142	155	165	
MBh	32.1	32.8	35.0	37.4	31.3	32.0	34.2	36.5	30.6	31.2	33.4	35.7	29.8	30.5	32.6	34.8	28.3	29.0	30.9	33.1	26.2	26.8	28.7	30.6	
S/T	0.87	0.82	0.67	0.50	0.90	0.85	0.69	0.52	0.93	0.87	0.71	0.53	0.96	0.90	0.73	0.55	0.99	0.93	0.76	0.57	1.00	0.94	0.76	0.57	
ΔT	25	24	21	17	25	24	21	17	25	24	21	17	26	25	21	17	25	24	21	17	24	23	20	16	
1025 kW	1.83	1.88	1.94	2.01	1.99	2.03	2.10	2.18	2.12	2.17	2.25	2.33	2.24	2.29	2.38	2.46	2.34	2.40	2.48	2.57	2.43	2.49	2.58	2.67	
Amps	7.1	7.2	7.5	7.8	7.7	7.9	8.1	8.4	8.4	8.6	8.9	9.2	9.0	9.2	9.5	9.9	9.6	9.8	10.1	10.5	10.2	10.4	10.8	11.2	
Hi PR	212	227	231	236	239	257	261	267	272	292	297	303	310	333	338	345	348	375	380	388	390	420	426	435	
Lo PR	119	123	134	143	123	126	138	147	127	131	143	152	130	134	147	156	133	137	149	159	136	140	153	163	
85	MBh	36.4	37.1	38.9	41.5	35.6	36.2	38.0	40.5	34.7	35.4	37.1	39.5	33.9	34.5	36.2	38.6	32.2	32.8	34.3	36.6	29.8	30.4	31.8	33.9
	S/T	0.99	0.96	0.87	0.70	1.00	0.99	0.90	0.73	1.00	1.00	0.92	0.75	1.00	1.00	0.95	0.77	1.00	1.00	0.99	0.80	1.00	1.00	0.99	0.81
	ΔT	25	25	23	20	25	25	24	20	24	25	24	20	23	24	24	21	22	23	23	20	21	21	22	19
	1325 kW	1.87	1.91	1.97	2.04	2.02	2.07	2.14	2.22	2.16	2.21	2.29	2.37	2.28	2.34	2.42	2.51	2.39	2.44	2.53	2.62	2.47	2.53	2.62	2.72
	Amps	7.2	7.4	7.6	7.9	7.8	8.0	8.3	8.6	8.5	8.7	9.0	9.4	9.1	9.4	9.7	10.1	9.7	10.0	10.3	10.8	10.4	10.6	11.0	11.4
	Hi PR	216	232	235	241	244	262	266	272	277	298	303	309	316	340	345	352	356	382	388	396	398	428	434	444
	Lo PR	121	125	137	146	125	129	141	150	129	133	146	155	133	137	149	159	135	140	152	162	139	143	156	166
	MBh	35.3	36.0	37.7	40.3	34.5	35.2	36.9	39.3	33.7	34.4	36.0	38.4	32.9	33.5	35.1	37.4	31.2	31.8	33.3	35.6	28.9	29.5	30.9	33.0
	S/T	0.95	0.92	0.83	0.67	0.98	0.95	0.86	0.69	1.00	0.97	0.88	0.71	1.00	1.00	0.91	0.74	1.00	1.00	0.94	0.76	1.00	1.00	0.95	0.77
	ΔT	26	26	24	21	27	26	25	21	26	26	25	21	26	26	25	22	24	25	25	21	23	23	23	20
1175 kW	1.85	1.89	1.96	2.03	2.00	2.05	2.12	2.20	2.14	2.19	2.27	2.35	2.26	2.32	2.40	2.48	2.36	2.42	2.51	2.60	2.45	2.51	2.60	2.69	
Amps	7.1	7.3	7.6	7.9	7.7	7.9	8.2	8.5	8.4	8.7	9.0	9.3	9.0	9.3	9.6	10.0	9.7	9.9	10.2	10.6	10.3	10.5	10.9	11.3	
Hi PR	214	230	233	238	242	260	263	269	275	295	300	306	313	336	341	349	352	378	384	392	394	424	430	439	
Lo PR	120	124	135	144	124	128	139	148	128	132	144	154	131	136	148	158	134	138	151	161	137	142	155	165	
MBh	32.6	33.3	34.8	37.2	31.9	32.5	34.0	36.3	31.1	31.7	33.2	35.4	30.3	30.9	32.4	34.6	28.8	29.4	30.8	32.8	26.7	27.2	28.5	30.4	
S/T	0.91	0.88	0.80	0.65	0.95	0.91	0.83	0.67	0.97	0.94	0.85	0.69	1.00	0.97	0.87	0.71	1.00	1.00	0.91	0.74	1.00	1.00	0.91	0.74	
ΔT	26.8	26	25	22	27	27	25	22	27	27	25	22	27	27	25	22	26	26	25	22	24	24	23	20	
1025 kW	1.83	1.88	1.94	2.01	1.99	2.03	2.10	2.18	2.12	2.17	2.25	2.33	2.24	2.29	2.38	2.46	2.34	2.40	2.48	2.57	2.43	2.49	2.58	2.67	
Amps	7.1	7.2	7.5	7.8	7.7	7.9	8.1	8.4	8.4	8.6	8.9	9.2	9.0	9.2	9.5	9.9	9.6	9.8	10.1	10.5	10.2	10.4	10.8	11.2	
Hi PR	212	227	231	236	239	257	261	267	272	292	297	303	310	333	338	345	348	375	380	388	390	420	426	435	
Lo PR	119	123	134	143	123	126	138	147	127	131	143	152	130	134	147	156	133	137	149	159	136	140	153	163	

IDB = Entering Indoor Dry Bulb Temperature
 High and low pressures are measured at the liquid and suction service valves.
 Shaded area reflects AHRI (TVSA) conditions
 kW = Total system power
 Amps = outdoor unit amps (comp.+fan)

COOLING DATA — DSXC180481A* / CA*F4961*6** +TXV / MBVC2000** -1 HIGH STAGE

IDB	AIRFLOW	OUTDOOR AMBIENT TEMPERATURE												ENTERING INDOOR WET BULB TEMPERATURE											
		65°F				75°F				85°F				95°F				105°F				115°F			
		59	63	67	71	59	63	67	71	59	63	67	71	59	63	67	71	59	63	67	71	59	63	67	71
70	MBh	48.2	50.0	54.8	-	47.1	48.8	53.5	-	46.0	47.7	52.2	-	44.9	46.5	50.9	-	42.6	44.2	48.4	-	39.5	40.9	44.8	-
	S/T	0.77	0.64	0.44	-	0.79	0.66	0.46	-	0.81	0.68	0.47	-	0.84	0.70	0.49	-	0.87	0.73	0.50	-	0.88	0.73	0.51	-
	ΔT	17	15	11	-	17	15	11	-	17	15	11	-	18	15	12	-	17	15	11	-	16	14	11	-
	kW	2.87	2.94	3.03	-	3.10	3.17	3.27	-	3.30	3.37	3.48	-	3.47	3.55	3.67	-	3.62	3.70	3.83	-	3.75	3.84	3.97	-
	Amps	10.2	10.5	10.8	-	11.1	11.4	11.7	-	12.1	12.4	12.8	-	13.0	13.3	13.7	-	13.8	14.2	14.7	-	14.7	15.1	15.6	-
	Hi PR	228	245	248	-	257	277	280	-	292	315	319	-	333	358	363	-	375	403	409	-	420	451	458	-
	Lo PR	121	124	136	-	124	128	140	-	128	132	145	-	132	136	148	-	134	139	151	-	138	142	155	-
	MBh	46.8	48.5	53.2	-	45.7	47.4	51.9	-	44.6	46.3	50.7	-	43.5	45.1	49.5	-	41.4	42.9	47.0	-	38.3	39.7	43.5	-
	S/T	0.73	0.61	0.42	-	0.76	0.63	0.44	-	0.78	0.65	0.45	-	0.80	0.67	0.46	-	0.83	0.69	0.48	-	0.84	0.70	0.48	-
	ΔT	18	16	12	-	18	16	12	-	18	16	12	-	18	16	12	-	18	16	12	-	17	15	11	-
	kW	2.85	2.91	3.01	-	3.07	3.14	3.24	-	3.27	3.34	3.45	-	3.44	3.52	3.64	-	3.59	3.67	3.80	-	3.72	3.80	3.93	-
	Amps	10.1	10.4	10.7	-	11.0	11.2	11.6	-	12.0	12.3	12.7	-	12.8	13.2	13.6	-	13.7	14.0	14.5	-	14.5	14.9	15.4	-
Hi PR	225	242	246	-	255	274	278	-	290	311	316	-	330	355	360	-	371	399	405	-	416	447	453	-	
Lo PR	119	123	134	-	123	127	138	-	127	131	143	-	130	135	147	-	133	137	150	-	136	141	154	-	
MBh	43.2	44.8	49.1	-	42.2	43.7	47.9	-	41.2	42.7	46.8	-	40.2	41.7	45.6	-	38.2	39.6	43.4	-	35.4	36.7	40.2	-	
S/T	0.70	0.59	0.41	-	0.73	0.61	0.42	-	0.75	0.62	0.43	-	0.77	0.64	0.45	-	0.80	0.67	0.46	-	0.81	0.67	0.47	-	
ΔT	18	16	12	-	19	16	12	-	19	16	12	-	19	16	12	-	18	16	12	-	17	15	11	-	
kW	2.83	2.89	2.98	-	3.05	3.12	3.22	-	3.24	3.32	3.43	-	3.42	3.49	3.61	-	3.56	3.64	3.76	-	3.69	3.77	3.90	-	
Amps	10.0	10.3	10.6	-	10.9	11.1	11.5	-	11.9	12.2	12.6	-	12.7	13.0	13.5	-	13.6	13.9	14.4	-	14.4	14.8	15.3	-	
Hi PR	223	240	243	-	252	271	275	-	287	308	313	-	327	351	356	-	367	395	401	-	411	442	449	-	
Lo PR	118	122	133	-	122	125	137	-	126	130	142	-	129	133	145	-	132	136	148	-	135	139	152	-	

75	MBh	49.0	50.5	54.6	58.7	47.9	49.3	53.4	57.3	46.8	48.1	52.1	55.9	45.6	47.0	50.8	54.6	43.3	44.6	48.3	51.8	40.1	41.3	44.7	48.0
	S/T	0.87	0.78	0.59	0.38	0.90	0.81	0.61	0.39	0.92	0.83	0.63	0.40	0.95	0.85	0.65	0.42	0.99	0.89	0.67	0.43	1.00	0.89	0.68	0.44
	ΔT	20	18	15	10	20	19	15	11	20	19	15	11	20	19	15	11	20	18	15	10	19	17	14	10
	kW	2.87	2.94	3.03	3.13	3.10	3.17	3.27	3.38	3.30	3.37	3.48	3.60	3.47	3.55	3.67	3.80	3.62	3.70	3.83	3.96	3.75	3.84	3.97	4.10
	Amps	10.2	10.5	10.8	11.2	11.1	11.4	11.7	12.2	12.1	12.4	12.8	13.3	13.0	13.3	13.7	14.3	13.8	14.2	14.7	15.3	14.7	15.1	15.6	16.2
	Hi PR	228	245	248	254	257	277	280	287	292	315	319	326	333	358	363	371	375	403	409	418	420	451	458	468
	Lo PR	121	124	136	145	124	128	140	149	128	132	145	154	132	136	148	158	134	139	151	161	138	142	155	165
	MBh	47.6	49.0	53.1	56.9	46.5	47.9	51.8	55.6	45.4	46.7	50.6	54.3	44.3	45.6	49.4	53.0	42.1	43.3	46.9	50.3	39.0	40.1	43.4	46.6
	S/T	0.83	0.74	0.56	0.36	0.86	0.77	0.58	0.37	0.88	0.79	0.60	0.38	0.91	0.81	0.62	0.40	0.94	0.84	0.64	0.41	0.95	0.85	0.64	0.41
	ΔT	21	19	16	11	21	19	16	11	21	19	16	11	21	20	16	11	21	19	16	11	20	18	15	10
	kW	2.85	2.91	3.01	3.10	3.07	3.14	3.24	3.35	3.27	3.34	3.45	3.57	3.44	3.52	3.64	3.76	3.59	3.67	3.80	3.93	3.72	3.80	3.93	4.07
	Amps	10.1	10.4	10.7	11.1	11.0	11.2	11.6	12.1	12.0	12.3	12.7	13.2	12.8	13.2	13.6	14.2	13.7	14.0	14.5	15.1	14.5	14.9	15.4	16.0
Hi PR	225	242	246	251	255	274	278	284	290	311	316	323	330	355	360	368	371	399	405	414	416	447	453	463	
Lo PR	119	123	134	143	123	127	138	147	127	131	143	152	130	135	147	156	133	137	150	160	136	141	154	163	
MBh	43.9	45.2	49.0	52.6	42.9	44.2	47.8	51.3	41.9	43.1	46.7	50.1	40.9	42.1	45.6	48.9	38.8	40.0	43.3	46.4	36.0	37.0	40.1	43.0	
S/T	0.80	0.72	0.54	0.35	0.83	0.74	0.56	0.36	0.85	0.76	0.58	0.37	0.88	0.79	0.59	0.38	0.91	0.81	0.62	0.40	0.92	0.82	0.62	0.40	
ΔT	21	19	16	11	21	20	16	11	21	20	16	11	22	20	16	11	21	20	16	11	20	18	15	10	
kW	2.83	2.89	2.98	3.08	3.05	3.12	3.22	3.32	3.24	3.32	3.43	3.54	3.42	3.49	3.61	3.73	3.56	3.64	3.76	3.89	3.69	3.77	3.90	4.03	
Amps	10.0	10.3	10.6	11.0	10.9	11.1	11.5	12.0	11.9	12.2	12.6	13.1	12.7	13.0	13.5	14.0	13.6	13.9	14.4	15.0	14.4	14.8	15.3	15.9	
Hi PR	223	240	243	249	252	271	275	281	287	308	313	320	327	351	356	364	367	395	401	409	411	442	449	459	
Lo PR	118	122	133	142	122	125	137	146	126	130	142	151	129	133	145	155	132	136	148	158	135	139	152	162	

IDB = Entering Indoor Dry Bulb Temperature
 High and low pressures are measured at the liquid and suction service valves.
 Shaded area reflects ACCA (TVA) conditions
 kW = Total system power
 Amps = outdoor unit amps (comp. + fan)

COOLING DATA — DSXC180481A* / CA*F4961*6** +TXV / MBVC2000** -1 HIGH STAGE (CONT.)

IDB	AIRFLOW	OUTDOOR AMBIENT TEMPERATURE												ENTERING INDOOR WET BULB TEMPERATURE											
		65°F				75°F				85°F				95°F				105°F				115°F			
		59	63	67	71	59	63	67	71	59	63	67	71	59	63	67	71	59	63	67	71	59	63	67	71
1970	MBh	49.9	51.0	54.5	58.2	48.7	49.8	53.2	56.9	47.6	48.6	52.0	55.5	46.4	47.4	50.7	54.2	44.1	45.1	48.1	51.5	40.9	41.7	44.6	47.7
	S/T	0.95	0.89	0.73	0.54	1.00	0.93	0.75	0.56	1.00	0.95	0.77	0.58	1.00	1.00	0.80	0.60	1.00	1.00	0.83	0.62	1.00	1.00	0.84	0.63
	ΔT	22	21	19	15	23	22	19	15	22	22	19	15	22	22	19	15	21	21	19	15	19	19	17	14
	kW	2.87	2.94	3.03	3.13	3.10	3.17	3.27	3.38	3.30	3.37	3.48	3.60	3.47	3.55	3.67	3.80	3.62	3.70	3.83	3.96	3.75	3.84	3.97	4.10
	Amps	10.2	10.5	10.8	11.2	11.1	11.4	11.7	12.2	12.1	12.4	12.8	13.3	13.0	13.3	13.7	14.3	13.8	14.2	14.7	15.3	14.7	15.1	15.6	16.2
	HI PR	228	245	248	254	257	277	280	287	292	315	319	326	333	358	363	371	375	403	409	418	420	451	458	468
Lo PR	121	124	136	145	124	128	140	149	128	132	145	154	132	136	148	158	134	139	151	161	138	142	155	165	
80	MBh	48.5	49.5	52.9	56.5	47.3	48.4	51.7	55.2	46.2	47.2	50.4	53.9	45.1	46.1	49.2	52.6	42.8	43.8	46.7	50.0	39.7	40.5	43.3	46.3
	S/T	0.91	0.85	0.69	0.52	0.94	0.88	0.72	0.54	0.97	0.91	0.74	0.55	1.00	0.94	0.76	0.57	1.00	0.97	0.79	0.59	1.00	0.98	0.80	0.60
	ΔT	23	22	19	15	23	22	20	16	23	22	20	16	24	23	20	16	22	22	19	16	21	21	18	14
	kW	2.85	2.91	3.01	3.10	3.07	3.14	3.24	3.35	3.27	3.34	3.45	3.57	3.44	3.52	3.64	3.76	3.59	3.67	3.80	3.93	3.72	3.80	3.93	4.07
	Amps	10.1	10.4	10.7	11.1	11.0	11.2	11.6	12.1	12.0	12.3	12.7	13.2	12.8	13.2	13.6	14.2	13.7	14.0	14.5	15.1	14.5	14.9	15.4	16.0
	HI PR	225	242	246	251	255	274	278	284	290	311	316	323	330	355	360	368	371	399	405	414	416	447	453	463
Lo PR	119	123	134	143	123	127	138	147	127	131	143	152	130	135	147	156	133	137	150	160	136	141	154	163	
1530	MBh	44.7	45.7	48.8	52.2	43.7	44.6	47.7	51.0	42.6	43.6	46.6	49.8	41.6	42.5	45.4	48.6	39.5	40.4	43.1	46.1	36.6	37.4	40.0	42.7
	S/T	0.88	0.82	0.67	0.50	0.91	0.85	0.69	0.52	0.93	0.87	0.71	0.53	0.96	0.90	0.73	0.55	1.00	0.94	0.76	0.57	1.01	0.94	0.77	0.57
	ΔT	24	23	20	16	24	23	20	16	24	23	20	16	24	23	20	16	24	23	20	16	22	21	18	15
	kW	2.83	2.89	2.98	3.08	3.05	3.12	3.22	3.32	3.24	3.32	3.43	3.54	3.42	3.49	3.61	3.73	3.56	3.64	3.76	3.89	3.69	3.77	3.90	4.03
	Amps	10.0	10.3	10.6	11.0	10.9	11.1	11.5	12.0	11.9	12.2	12.6	13.1	12.7	13.0	13.5	14.0	13.6	13.9	14.4	15.0	14.4	14.8	15.3	15.9
	HI PR	223	240	243	249	252	271	275	281	287	308	313	320	327	351	356	364	367	395	401	409	411	442	449	459
Lo PR	118	122	133	142	122	125	137	146	126	130	142	151	129	133	145	155	132	136	148	158	135	139	152	162	
1970	MBh	50.8	51.8	54.2	57.8	49.6	50.6	53.0	56.5	48.4	49.4	51.7	55.1	47.2	48.2	50.4	53.8	44.9	45.7	47.9	51.1	41.6	42.4	44.4	47.3
	S/T	1.00	0.97	0.87	0.71	1.00	1.00	0.90	0.73	1.00	1.00	0.93	0.75	1.00	1.00	0.96	0.78	1.00	1.00	0.99	0.80	1.00	1.00	1.00	0.81
	ΔT	24	23	22	19	23	24	22	19	23	23	22	19	22	22	22	19	21	21	22	19	19	20	21	18
	kW	2.87	2.94	3.03	3.13	3.10	3.17	3.27	3.38	3.30	3.37	3.48	3.60	3.47	3.55	3.67	3.80	3.62	3.70	3.83	3.96	3.75	3.84	3.97	4.10
	Amps	10.2	10.5	10.8	11.2	11.1	11.4	11.7	12.2	12.1	12.4	12.8	13.3	13.0	13.3	13.7	14.3	13.8	14.2	14.7	15.3	14.7	15.1	15.6	16.2
	HI PR	228	245	248	254	257	277	280	287	292	315	319	326	333	358	363	371	375	403	409	418	420	451	458	468
Lo PR	121	124	136	145	124	128	140	149	128	132	145	154	132	136	148	158	134	139	151	161	138	142	155	165	
1750	MBh	49.3	50.3	52.6	56.2	48.2	49.1	51.4	54.8	47.0	47.9	50.2	53.5	45.9	46.7	49.0	52.2	43.6	44.4	46.5	49.6	40.4	41.1	43.1	46.0
	S/T	0.95	0.92	0.83	0.67	0.99	0.95	0.86	0.70	1.00	0.98	0.88	0.72	1.00	1.00	0.91	0.74	1.00	1.00	0.95	0.77	1.00	1.00	0.95	0.77
	ΔT	25	24	23	20	25	25	23	20	25	25	23	20	24	25	23	20	23	23	23	20	21	22	22	19
	kW	2.85	2.91	3.01	3.10	3.07	3.14	3.24	3.35	3.27	3.34	3.45	3.57	3.44	3.52	3.64	3.76	3.59	3.67	3.80	3.93	3.72	3.80	3.93	4.07
	Amps	10.1	10.4	10.7	11.1	11.0	11.2	11.6	12.1	12.0	12.3	12.7	13.2	12.8	13.2	13.6	14.2	13.7	14.0	14.5	15.1	14.5	14.9	15.4	16.0
	HI PR	225	242	246	251	255	274	278	284	290	311	316	323	330	355	360	368	371	399	405	414	416	447	453	463
Lo PR	119	123	134	143	123	127	138	147	127	131	143	152	130	135	147	156	133	137	150	160	136	141	154	163	
1530	MBh	45.5	46.4	48.6	51.8	44.4	45.3	47.5	50.6	43.4	44.2	46.3	49.4	42.3	43.1	45.2	48.2	40.2	41.0	42.9	45.8	37.3	38.0	39.8	42.4
	S/T	0.92	0.89	0.80	0.65	0.95	0.92	0.83	0.67	0.98	0.94	0.85	0.69	1.00	0.97	0.88	0.71	1.00	1.00	0.91	0.74	1.00	1.00	0.92	0.75
	ΔT	25	25	23	20	25	25	24	21	25	25	24	21	25	25	24	21	24	25	24	20	22	23	22	19
	kW	2.83	2.89	2.98	3.08	3.05	3.12	3.22	3.32	3.24	3.32	3.43	3.54	3.42	3.49	3.61	3.73	3.56	3.64	3.76	3.89	3.69	3.77	3.90	4.03
	Amps	10.0	10.3	10.6	11.0	10.9	11.1	11.5	12.0	11.9	12.2	12.6	13.1	12.7	13.0	13.5	14.0	13.6	13.9	14.4	15.0	14.4	14.8	15.3	15.9
	HI PR	223	240	243	249	252	271	275	281	287	308	313	320	327	351	356	364	367	395	401	409	411	442	449	459
Lo PR	118	122	133	142	122	125	137	146	126	130	142	151	129	133	145	155	132	136	148	158	135	139	152	162	

IDB = Entering Indoor Dry Bulb Temperature
 High and low pressures are measured at the liquid and suction service valves.
 Shaded area reflects AHRI (TVA) conditions
 kW = Total system power
 Amps = outdoor unit amps (comp. + fan)

COOLING DATA — DSXC180601A* / CA*F4961*6** +TXV / MBVC2000** -1 LOW STAGE

IDB	AIRFLOW	OUTDOOR AMBIENT TEMPERATURE																									
		65°F				75°F				85°F				95°F				105°F				115°F					
		59	63	67	71	59	63	67	71	59	63	67	71	59	63	67	71	59	63	67	71	59	63	67	71		
70	1520	MBh	42.4	43.9	48.1	-	41.4	42.9	47.0	-	40.4	41.9	45.9	-	39.4	40.8	44.7	-	37.4	38.8	42.5	-	34.7	35.9	39.4	-	
		S/T	0.73	0.61	0.42	-	0.75	0.63	0.44	-	0.77	0.65	0.45	-	0.80	0.67	0.46	-	0.83	0.69	0.48	-	0.83	0.70	0.48	-	
	ΔT	19	16	12	-	19	16	12	-	19	16	12	-	19	16	12	-	19	16	12	-	17	15	11	-		
	1350	kW	2.43	2.49	2.57	-	2.64	2.70	2.79	-	2.82	2.89	2.99	-	2.98	3.05	3.16	-	3.12	3.19	3.31	-	3.24	3.31	3.43	-	
		Amps	9.4	9.6	10.0	-	10.2	10.4	10.8	-	11.1	11.4	11.8	-	11.9	12.2	12.6	-	14.0	14.3	14.8	-	14.8	15.1	15.7	-	
	1180	HI PR	226	243	247	-	248	267	271	-	291	313	317	-	331	356	361	-	372	400	406	-	430	463	469	-	
		Lo PR	118	122	133	-	121	125	137	-	125	129	141	-	129	133	145	-	131	136	148	-	135	139	152	-	
	75	1520	MBh	41.1	42.6	46.7	-	40.2	41.6	45.6	-	39.2	40.6	44.5	-	38.3	39.6	43.4	-	36.3	37.7	41.3	-	33.7	34.9	38.2	-
			S/T	0.69	0.58	0.40	-	0.72	0.60	0.42	-	0.74	0.62	0.43	-	0.76	0.64	0.44	-	0.79	0.66	0.46	-	0.80	0.66	0.46	-
		ΔT	19	17	13	-	20	17	13	-	20	17	13	-	20	17	13	-	20	17	13	-	18	16	12	-	
		1350	kW	2.41	2.47	2.55	-	2.61	2.68	2.77	-	2.80	2.86	2.96	-	2.95	3.03	3.13	-	3.09	3.16	3.28	-	3.21	3.28	3.40	-
			Amps	9.3	9.5	9.9	-	10.1	10.3	10.7	-	11.0	11.3	11.7	-	11.8	12.1	12.5	-	13.8	14.2	14.7	-	14.6	15.0	15.5	-
1180		HI PR	224	241	244	-	246	264	268	-	288	309	314	-	328	352	357	-	369	397	402	-	426	458	465	-	
		Lo PR	117	120	131	-	120	124	135	-	124	128	140	-	128	132	144	-	130	134	146	-	133	137	150	-	
75		1520	MBh	38.0	39.3	43.1	-	37.1	38.4	42.1	-	36.2	37.5	41.1	-	35.3	36.6	40.1	-	33.5	34.8	38.1	-	31.1	32.2	35.3	-
			S/T	0.67	0.56	0.39	-	0.69	0.58	0.40	-	0.71	0.59	0.41	-	0.73	0.61	0.42	-	0.76	0.64	0.44	-	0.77	0.64	0.44	-
		ΔT	20	17	13	-	20	17	13	-	20	17	13	-	20	17	13	-	20	17	13	-	19	16	12	-	
		1350	kW	2.39	2.44	2.53	-	2.59	2.65	2.75	-	2.77	2.84	2.94	-	2.93	3.00	3.10	-	3.06	3.14	3.25	-	3.18	3.25	3.37	-
			Amps	9.2	9.4	9.8	-	10.0	10.2	10.6	-	10.9	11.2	11.6	-	11.7	12.0	12.4	-	13.7	14.0	14.5	-	14.5	14.8	15.4	-
	1180	HI PR	222	238	242	-	243	262	265	-	285	306	311	-	325	349	354	-	365	393	398	-	422	454	460	-	
		Lo PR	116	119	130	-	119	123	134	-	123	127	138	-	126	130	142	-	129	133	145	-	132	136	149	-	
	75	1520	MBh	43.1	44.3	48.0	51.5	42.1	43.3	46.9	50.3	41.1	42.3	45.8	49.1	40.1	41.3	44.7	47.9	38.1	39.2	42.4	45.5	35.3	36.3	39.3	42.2
			S/T	0.83	0.74	0.56	0.36	0.86	0.77	0.58	0.37	0.88	0.79	0.59	0.38	0.91	0.81	0.61	0.39	0.94	0.84	0.64	0.41	0.95	0.85	0.64	0.41
		ΔT	22	20	16	11	22	20	16	11	22	20	16	11	22	20	17	11	22	20	16	11	20	19	15	11	
		1350	kW	2.43	2.49	2.57	2.67	2.64	2.70	2.79	2.89	2.82	2.89	2.99	3.10	2.98	3.05	3.16	3.28	3.12	3.19	3.31	3.43	3.24	3.31	3.43	3.56
			Amps	9.4	9.6	10.0	10.3	10.2	10.4	10.8	11.2	11.1	11.4	11.8	12.2	11.9	12.2	12.6	13.1	14.0	14.3	14.8	15.4	14.8	15.1	15.7	16.3
1180		HI PR	226	243	247	252	248	267	271	277	291	313	317	324	331	356	361	369	372	400	406	415	430	463	469	480	
		Lo PR	118	122	133	141	121	125	137	146	125	129	141	150	129	133	145	154	131	136	148	158	135	139	152	161	
75		1520	MBh	41.8	43.1	46.6	50.0	40.8	42.1	45.5	48.9	39.9	41.1	44.4	47.7	38.9	40.1	43.4	46.5	37.0	38.0	41.2	44.2	34.2	35.2	38.1	40.9
			S/T	0.79	0.70	0.53	0.34	0.82	0.73	0.55	0.36	0.84	0.75	0.57	0.36	0.86	0.77	0.59	0.38	0.90	0.80	0.61	0.39	0.90	0.81	0.61	0.39
		ΔT	22	21	17	12	23	21	17	12	23	21	17	12	23	21	17	12	23	21	17	12	21	19	16	11	
		1350	kW	2.41	2.47	2.55	2.64	2.61	2.68	2.77	2.87	2.80	2.86	2.96	3.07	2.95	3.03	3.13	3.25	3.09	3.16	3.28	3.40	3.21	3.28	3.40	3.53
			Amps	9.3	9.5	9.9	10.2	10.1	10.3	10.7	11.1	11.0	11.3	11.7	12.1	11.8	12.1	12.5	13.0	13.8	14.2	14.7	15.3	14.6	15.0	15.5	16.1
	1180	HI PR	224	241	244	250	246	264	268	274	288	309	314	321	328	352	357	365	369	397	402	411	426	458	465	475	
		Lo PR	117	120	131	140	120	124	135	144	124	128	140	149	128	132	144	153	130	134	146	156	133	137	150	160	
	75	1520	MBh	38.6	39.7	43.0	46.2	37.7	38.8	42.0	45.1	36.8	37.9	41.0	44.0	35.9	37.0	40.0	42.9	34.1	35.1	38.0	40.8	31.6	32.5	35.2	37.8
			S/T	0.76	0.68	0.51	0.33	0.79	0.70	0.53	0.34	0.81	0.72	0.55	0.35	0.83	0.75	0.56	0.36	0.87	0.77	0.59	0.38	0.87	0.78	0.59	0.38
		ΔT	23	21	17	12	23	21	17	12	23	21	17	12	23	21	18	12	23	21	17	12	21	20	16	11	
		1350	kW	2.39	2.44	2.53	2.62	2.59	2.65	2.75	2.84	2.77	2.84	2.94	3.04	2.93	3.00	3.10	3.22	3.06	3.14	3.25	3.37	3.18	3.25	3.37	3.49
			Amps	9.2	9.4	9.8	10.1	10.0	10.2	10.6	11.0	10.9	11.2	11.6	12.0	11.7	12.0	12.4	12.9	13.7	14.0	14.5	15.1	14.5	14.8	15.4	16.0
1180		HI PR	222	238	242	247	243	262	265	271	285	306	311	318	325	349	354	362	365	393	398	407	422	454	460	470	
		Lo PR	116	119	130	139	119	123	134	143	123	127	138	147	126	130	142	151	129	133	145	154	132	136	149	158	

IDB = Entering Indoor Dry Bulb Temperature
 High and low pressures are measured at the liquid and suction service valves.
 Shaded area reflects ACCA (TVA) conditions
 kW = Total system power
 Amps = outdoor unit amps (comp.+fan)

COOLING DATA — DSXC180601A* / CA*F4961*6** +TXV / MBVC2000*-1 LOW STAGE (CONT.)

IDB	AIRFLOW	OUTDOOR AMBIENT TEMPERATURE												ENTERING INDOOR WET BULB TEMPERATURE													
		65°F				75°F				85°F				95°F				105°F				115°F					
		59	63	67	71	59	63	67	71	59	63	67	71	59	63	67	71	59	63	67	71	59	63	67	71		
80	1520	MBh	43.8	44.8	47.9	51.2	42.8	43.8	46.7	50.0	41.8	42.7	45.6	48.8	40.8	41.7	44.5	47.6	38.7	39.6	42.3	45.2	35.9	36.7	39.2	41.9	
		S/T	0.91	0.85	0.69	0.52	0.94	0.88	0.72	0.54	0.96	0.90	0.74	0.55	1.00	0.93	0.76	0.57	1.00	0.97	0.79	0.59	1.00	1.00	0.79	0.59	
		ΔT	24	23	20	16	24	23	20	16	24	23	20	16	25	23	20	16	22	23	20	16	22	22	19	15	
	1350	kW	2.43	2.49	2.57	2.67	2.64	2.70	2.79	2.89	2.82	2.89	2.99	3.10	2.98	3.05	3.16	3.28	3.12	3.19	3.31	3.43	3.24	3.31	3.43	3.56	
		Amps	9.4	9.6	10.0	10.3	10.2	10.4	10.8	11.2	11.1	11.4	11.8	12.2	11.9	12.2	12.6	13.1	14.0	14.3	14.8	15.4	14.8	15.1	15.7	16.3	
		Hi PR	226	243	247	252	248	267	271	277	291	291	313	317	324	331	356	361	369	372	400	406	415	430	463	469	480
	1180	Lo PR	118	122	133	141	121	125	137	146	125	129	141	150	129	133	145	154	131	136	148	158	135	139	152	161	
		MBh	42.6	43.5	46.5	49.7	41.6	42.5	45.4	48.5	40.6	41.5	44.3	47.4	39.6	40.5	43.2	46.2	37.6	38.4	41.1	43.9	34.8	35.6	38.0	40.7	
		S/T	0.86	0.81	0.66	0.49	0.90	0.84	0.68	0.51	0.92	0.86	0.70	0.52	0.95	0.89	0.72	0.54	0.98	0.92	0.75	0.56	0.99	0.93	0.76	0.57	
	85	1520	ΔT	25	24	21	17	25	24	21	17	25	24	21	17	26	24	21	17	25	24	21	17	24	23	20	16
			kW	2.41	2.47	2.55	2.64	2.61	2.68	2.77	2.87	2.80	2.86	2.96	3.07	2.95	3.03	3.13	3.25	3.09	3.16	3.28	3.40	3.21	3.28	3.40	3.53
			Amps	9.3	9.5	9.9	10.2	10.1	10.3	10.7	11.1	11.0	11.3	11.7	12.1	11.8	12.1	12.5	13.0	13.8	14.2	14.7	15.3	14.6	15.0	15.5	16.1
1350		Hi PR	224	241	244	250	246	264	268	274	288	309	314	321	328	352	357	365	369	397	402	411	426	458	465	475	
		Lo PR	117	120	131	140	120	124	135	144	124	128	140	149	128	132	144	153	130	134	146	156	133	137	150	160	
		MBh	39.3	40.1	42.9	45.8	38.4	39.2	41.9	44.8	37.5	38.3	40.9	43.7	36.5	37.3	39.9	42.6	34.7	35.5	37.9	40.5	32.2	32.9	35.1	37.5	
1180		S/T	0.83	0.78	0.64	0.48	0.86	0.81	0.66	0.49	0.89	0.83	0.68	0.51	0.91	0.86	0.70	0.52	0.95	0.89	0.72	0.54	0.96	0.90	0.73	0.55	
		ΔT	26	24	21	17	26	25	22	17	26	25	22	17	26	25	22	17	26	25	22	17	24	23	20	16	
		kW	2.39	2.44	2.53	2.62	2.59	2.65	2.75	2.84	2.77	2.84	2.94	3.04	2.93	3.00	3.10	3.22	3.06	3.14	3.25	3.37	3.18	3.25	3.37	3.49	
85		1520	Amps	9.2	9.4	9.8	10.1	10.0	10.2	10.6	11.0	10.9	11.2	11.6	12.0	11.7	12.0	12.4	12.9	13.7	14.0	14.5	15.1	14.5	14.8	15.4	16.0
			Hi PR	222	238	242	247	243	262	265	271	285	306	311	318	325	349	354	362	365	393	398	407	422	454	460	470
			Lo PR	116	119	130	139	119	123	134	143	123	127	138	147	126	130	142	151	129	133	145	154	132	136	149	158
	1350	MBh	44.6	45.5	47.6	50.8	43.6	44.4	46.5	49.6	42.5	43.4	45.4	48.4	41.5	42.3	44.3	47.3	39.4	40.2	42.1	44.9	36.5	37.2	39.0	41.6	
		S/T	0.95	0.92	0.83	0.67	0.98	0.95	0.86	0.70	1.00	0.97	0.88	0.71	1.00	1.00	0.91	0.74	1.00	1.00	0.94	0.76	1.00	1.00	0.95	0.77	
		ΔT	26	25	24	21	26	26	24	21	26	26	24	21	25	26	24	21	25	24	24	21	22	23	22	19	
	1180	kW	2.43	2.49	2.57	2.67	2.64	2.70	2.79	2.89	2.82	2.89	2.99	3.10	2.98	3.05	3.16	3.28	3.12	3.19	3.31	3.43	3.24	3.31	3.43	3.56	
		Amps	9.4	9.6	10.0	10.3	10.2	10.4	10.8	11.2	11.1	11.4	11.8	12.2	11.9	12.2	12.6	13.1	14.0	14.3	14.8	15.4	14.8	15.1	15.7	16.3	
		Hi PR	226	243	247	252	248	267	271	277	291	313	317	324	331	356	361	369	372	400	406	415	430	463	469	480	
	85	1350	Lo PR	118	122	133	141	121	125	137	146	125	129	141	150	129	133	145	154	131	136	148	158	135	139	152	161
			MBh	43.3	44.1	46.2	49.3	42.3	43.1	45.2	48.2	41.3	42.1	44.1	47.0	40.3	41.1	43.0	45.9	38.3	39.0	40.9	43.6	35.4	36.1	37.8	40.4
			S/T	0.91	0.87	0.79	0.64	0.94	0.91	0.82	0.66	0.96	0.93	0.84	0.68	0.99	0.96	0.87	0.70	1.00	1.00	0.90	0.73	1.00	1.00	0.91	0.73
1180	ΔT	27	26	25	22	27	27	25	22	27	27	25	22	27	27	25	22	26	26	25	22	24	25	23	20		
	kW	2.41	2.47	2.55	2.64	2.61	2.68	2.77	2.87	2.80	2.86	2.96	3.07	2.95	3.03	3.13	3.25	3.09	3.16	3.28	3.40	3.21	3.28	3.40	3.53		
	Amps	9.3	9.5	9.9	10.2	10.1	10.3	10.7	11.1	11.0	11.3	11.7	12.1	11.8	12.1	12.5	13.0	13.8	14.2	14.7	15.3	14.6	15.0	15.5	16.1		
85	1350	Hi PR	224	241	244	250	246	264	268	274	288	309	314	321	328	352	357	365	369	397	402	411	426	458	465	475	
		Lo PR	117	120	131	140	120	124	135	144	124	128	140	149	128	132	144	153	130	134	146	156	133	137	150	160	
		MBh	40.0	40.7	42.7	45.5	39.0	39.8	41.7	44.5	38.1	38.8	40.7	43.4	37.2	37.9	39.7	42.3	35.3	36.0	37.7	40.2	32.7	33.4	34.9	37.3	
85	1350	S/T	0.87	0.84	0.76	0.62	0.91	0.87	0.79	0.64	0.93	0.90	0.81	0.66	0.96	0.92	0.83	0.68	0.99	0.96	0.87	0.70	1.00	0.97	0.87	0.71	
		ΔT	27.2	27	25	22	28	27	26	22	28	27	26	22	28	27	26	22	27	27	25	22	25	25	24	21	
		kW	2.39	2.44	2.53	2.62	2.59	2.65	2.75	2.84	2.77	2.84	2.94	3.04	2.93	3.00	3.10	3.22	3.06	3.14	3.25	3.37	3.18	3.25	3.37	3.49	
85	1350	Amps	9.2	9.4	9.8	10.1	10.0	10.2	10.6	11.0	10.9	11.2	11.6	12.0	11.7	12.0	12.4	12.9	13.7	14.0	14.5	15.1	14.5	14.8	15.4	16.0	
		Hi PR	222	238	242	247	243	262	265	271	285	306	311	318	325	349	354	362	365	393	398	407	422	454	460	470	
		Lo PR	116	119	130	139	119	123	134	143	123	127	138	147	126	130	142	151	129	133	145	154	132	136	149	158	

IDB = Entering Indoor Dry Bulb Temperature
 High and low pressures are measured at the liquid and suction service valves.
 Shaded area reflects AHRI (TVA) conditions
 kW = Total system power
 Amps = outdoor unit amps (comp.+fan)

COOLING DATA — DSXC180601A* / CA*F4961*6** +TXV / MBVC2000** -1 HIGH STAGE

IDB	AIRFLOW	OUTDOOR AMBIENT TEMPERATURE												ENTERING INDOOR WET BULB TEMPERATURE											
		65°F				75°F				85°F				95°F				105°F				115°F			
		59	63	67	71	59	63	67	71	59	63	67	71	59	63	67	71	59	63	67	71	59	63	67	71
70	MBh	58.5	60.6	66.4	-	57.1	59.2	64.9	-	55.8	57.8	63.3	-	54.4	56.4	61.8	-	51.7	53.6	58.7	-	47.9	49.6	54.4	-
	S/T	0.73	0.61	0.42	-	0.76	0.63	0.44	-	0.78	0.65	0.45	-	0.80	0.67	0.47	-	0.83	0.70	0.48	-	0.84	0.70	0.49	-
	ΔT	18	15	12	-	18	15	12	-	18	15	12	-	18	15	12	-	18	15	12	-	16	14	11	-
	kW	3.87	3.96	4.09	-	4.18	4.27	4.41	-	4.45	4.55	4.70	-	4.69	4.80	4.96	-	4.89	5.00	5.17	-	5.07	5.18	5.36	-
	Amps	13.8	14.2	14.7	-	15.0	15.4	15.9	-	16.4	16.8	17.4	-	17.6	18.0	18.7	-	20.6	21.2	21.9	-	21.8	22.4	23.2	-
	HI PR	241	259	263	-	265	285	289	-	310	333	338	-	353	380	385	-	397	427	433	-	459	493	500	-
	Lo PR	115	119	130	-	118	122	133	-	123	126	138	-	126	130	142	-	128	132	144	-	131	136	148	-
	MBh	56.8	58.9	64.5	-	55.5	57.5	63.0	-	54.2	56.1	61.5	-	52.8	54.8	60.0	-	50.2	52.0	57.0	-	46.5	48.2	52.8	-
	S/T	0.70	0.58	0.40	-	0.72	0.60	0.42	-	0.74	0.62	0.43	-	0.77	0.64	0.44	-	0.80	0.66	0.46	-	0.80	0.67	0.46	-
	ΔT	18	16	12	-	18	16	12	-	18	16	12	-	19	16	12	-	18	16	12	-	17	15	11	-
	kW	3.84	3.93	4.05	-	4.15	4.24	4.38	-	4.41	4.51	4.66	-	4.65	4.75	4.91	-	4.85	4.96	5.13	-	5.02	5.14	5.31	-
	Amps	13.7	14.0	14.5	-	14.9	15.2	15.8	-	16.2	16.6	17.2	-	17.4	17.8	18.5	-	20.4	21.0	21.7	-	21.6	22.2	23.0	-
HI PR	239	257	260	-	262	282	286	-	307	330	335	-	349	376	381	-	393	423	429	-	454	488	495	-	
Lo PR	114	118	128	-	117	121	132	-	121	125	137	-	125	128	140	-	127	131	143	-	130	134	147	-	
MBh	52.4	54.3	59.5	-	51.2	53.1	58.1	-	50.0	51.8	56.8	-	48.8	50.5	55.4	-	46.3	48.0	52.6	-	42.9	44.5	48.7	-	
S/T	0.67	0.56	0.39	-	0.70	0.58	0.40	-	0.72	0.60	0.41	-	0.74	0.62	0.43	-	0.77	0.64	0.44	-	0.77	0.65	0.45	-	
ΔT	19	16	12	-	19	16	12	-	19	16	12	-	19	16	12	-	19	16	12	-	17	15	11	-	
kW	3.81	3.89	4.02	-	4.11	4.20	4.34	-	4.38	4.47	4.62	-	4.61	4.71	4.87	-	4.81	4.92	5.08	-	4.98	5.09	5.27	-	
Amps	13.5	13.9	14.4	-	14.7	15.1	15.6	-	16.1	16.5	17.1	-	17.2	17.7	18.3	-	20.2	20.8	21.5	-	21.4	22.0	22.7	-	
HI PR	236	254	258	-	259	279	283	-	304	327	331	-	346	372	377	-	389	419	424	-	450	484	490	-	
Lo PR	113	116	127	-	116	120	131	-	120	124	135	-	123	127	139	-	126	130	142	-	129	133	145	-	
75	MBh	59.5	61.3	66.3	71.2	58.1	59.8	64.8	69.5	56.7	58.4	63.2	67.8	55.3	57.0	61.7	66.2	52.6	54.1	58.6	62.9	48.7	50.1	54.3	58.3
	S/T	0.83	0.75	0.56	0.36	0.86	0.77	0.58	0.38	0.89	0.79	0.60	0.39	0.91	0.82	0.62	0.40	0.95	0.85	0.64	0.41	0.96	0.86	0.65	0.42
	ΔT	20	19	15	11	20	19	15	11	21	19	15	11	21	19	16	11	20	19	15	11	19	18	14	10
	kW	3.87	3.96	4.09	4.22	4.18	4.27	4.41	4.56	4.45	4.55	4.70	4.86	4.69	4.80	4.96	5.13	4.89	5.00	5.17	5.35	5.07	5.18	5.36	5.55
	Amps	13.8	14.2	14.7	15.2	15.0	15.4	15.9	16.6	16.4	16.8	17.4	18.1	17.6	18.0	18.7	19.4	20.6	21.2	21.9	22.8	21.8	22.4	23.2	24.1
	HI PR	241	259	263	269	265	285	289	295	310	333	338	345	353	380	385	393	397	427	433	443	459	493	500	511
	Lo PR	115	119	130	138	118	122	133	142	123	126	138	147	126	130	142	151	128	132	144	154	131	136	148	158
	MBh	57.8	59.5	64.4	69.1	56.4	58.1	62.9	67.5	55.1	56.7	61.4	65.9	53.7	55.3	59.9	64.3	51.0	52.6	56.9	61.1	47.3	48.7	52.7	56.6
	S/T	0.79	0.71	0.54	0.35	0.82	0.74	0.56	0.36	0.84	0.76	0.57	0.37	0.87	0.78	0.59	0.38	0.90	0.81	0.61	0.39	0.91	0.82	0.62	0.40
	ΔT	21	19	16	11	21	20	16	11	21	20	16	11	22	20	16	11	21	20	16	11	20	18	15	10
	kW	3.84	3.93	4.05	4.19	4.15	4.24	4.38	4.52	4.41	4.51	4.66	4.82	4.65	4.75	4.91	5.08	4.85	4.96	5.13	5.31	5.02	5.14	5.31	5.50
	Amps	13.7	14.0	14.5	15.1	14.9	15.2	15.8	16.4	16.2	16.6	17.2	17.9	17.4	17.8	18.5	19.2	20.4	21.0	21.7	22.6	21.6	22.2	23.0	23.9
HI PR	239	257	260	266	262	282	286	292	307	330	335	342	349	376	381	389	393	423	429	438	454	488	495	506	
Lo PR	114	118	128	137	117	121	132	141	121	125	137	145	125	128	140	149	127	131	143	152	130	134	147	156	
MBh	53.3	54.9	59.4	63.8	52.1	53.6	58.0	62.3	50.8	52.3	56.7	60.8	49.6	51.1	55.3	59.3	47.1	48.5	52.5	56.4	43.6	44.9	48.6	52.2	
S/T	0.77	0.69	0.52	0.33	0.79	0.71	0.54	0.35	0.81	0.73	0.55	0.35	0.84	0.75	0.57	0.37	0.87	0.78	0.59	0.38	0.88	0.79	0.60	0.38	
ΔT	21	20	16	11	22	20	16	11	22	20	16	11	22	20	17	11	22	20	16	11	20	19	15	11	
kW	3.81	3.89	4.02	4.15	4.11	4.20	4.34	4.49	4.38	4.47	4.62	4.78	4.61	4.71	4.87	5.04	4.81	4.92	5.08	5.26	4.98	5.09	5.27	5.45	
Amps	13.5	13.9	14.4	14.9	14.7	15.1	15.6	16.2	16.1	16.5	17.1	17.7	17.2	17.7	18.3	19.0	20.2	20.8	21.5	22.3	21.4	22.0	22.7	23.6	
HI PR	236	254	258	263	259	279	283	289	304	327	331	339	346	372	377	386	389	419	424	434	450	484	490	501	
Lo PR	113	116	127	135	116	120	131	139	120	124	135	144	123	127	139	148	126	130	142	151	129	133	145	155	

IDB = Entering Indoor Dry Bulb Temperature
 High and low pressures are measured at the liquid and suction service valves.
 Shaded area reflects ACCA (TVA) conditions
 kW = Total system power
 Amps = outdoor unit amps (comp. + fan)

COOLING DATA — DSXC180601A* / CA*F4961*6** +TXV / MBVC2000** -1 HIGH STAGE (CONT.)

IDB	AIRFLOW	OUTDOOR AMBIENT TEMPERATURE																																			
		65°F						75°F						85°F						95°F						105°F						115°F					
		59	63	67	71	75	79	59	63	67	71	75	79	59	63	67	71	75	79	59	63	67	71	75	79	59	63	67	71	75	79	59	63	67	71	75	79
2250	MBh	60.6	61.9	66.1	70.7	59.1	60.4	64.6	69.0	57.7	59.0	63.0	67.4	56.3	57.6	61.5	65.7	53.5	54.7	58.4	62.4	49.6	50.6	54.1	57.8												
	S/T	0.91	0.86	0.70	0.52	0.95	0.89	0.72	0.54	1.00	0.91	0.74	0.55	1.00	0.94	0.77	0.57	1.00	1.00	0.79	0.59	1.00	1.00	0.80	0.60												
	ΔT	23	22	19	15	23	22	19	15	24	22	19	15	23	22	19	15	22	21	19	15	22	21	18	14												
	kW	3.87	3.96	4.09	4.22	4.18	4.27	4.41	4.56	4.45	4.55	4.70	4.86	4.69	4.80	4.96	5.13	4.89	5.00	5.17	5.35	5.07	5.18	5.36	5.55												
	Amps	13.8	14.2	14.7	15.2	15.0	15.4	15.9	16.6	16.4	16.8	17.4	18.1	17.6	18.0	18.7	19.4	20.6	21.2	21.9	22.8	21.8	22.4	23.2	24.1												
2000	HI PR	241	259	263	269	265	285	289	295	310	333	338	345	353	380	385	393	397	427	433	443	459	493	500	511												
	Lo PR	115	119	130	138	118	122	133	142	123	126	138	147	126	130	142	151	128	132	144	154	131	136	148	158												
	MBh	58.8	60.1	64.2	68.6	57.4	58.7	62.7	67.0	56.1	57.3	61.2	65.4	54.7	55.9	59.7	63.8	52.0	53.1	56.7	60.6	48.1	49.2	52.5	56.2												
	S/T	0.87	0.82	0.67	0.50	0.90	0.85	0.69	0.52	0.93	0.87	0.71	0.53	0.96	0.90	0.73	0.55	0.99	0.93	0.76	0.57	1.00	0.94	0.76	0.57												
	ΔT	24	23	20	16	24	23	20	16	24	23	20	16	24	23	20	16	24	23	20	16	22	21	18	15												
1750	kW	3.84	3.93	4.05	4.19	4.15	4.24	4.38	4.52	4.41	4.51	4.66	4.82	4.65	4.75	4.91	5.08	4.85	4.96	5.13	5.31	5.02	5.14	5.31	5.50												
	Amps	13.7	14.0	14.5	15.1	14.9	15.2	15.8	16.4	16.2	16.6	17.2	17.9	17.4	17.8	18.5	19.2	20.4	21.0	21.7	22.6	21.6	22.2	23.0	23.9												
	HI PR	239	257	260	266	262	282	286	292	307	330	335	342	349	376	381	389	393	423	429	438	454	488	495	506												
	Lo PR	114	118	128	137	117	121	132	141	121	125	137	145	125	128	140	149	127	131	143	152	130	134	147	156												
	MBh	54.3	55.4	59.2	63.3	53.0	54.2	57.9	61.9	51.7	52.9	56.5	60.4	50.5	51.6	55.1	58.9	48.0	49.0	52.3	56.0	44.4	45.4	48.5	51.8												
80	S/T	0.84	0.79	0.64	0.48	0.87	0.82	0.66	0.50	0.89	0.84	0.68	0.51	0.92	0.86	0.70	0.53	0.96	0.90	0.73	0.55	0.96	0.90	0.74	0.55												
	ΔT	24	23	20	16	24	23	20	16	24	23	20	16	24	23	20	16	24	23	20	16	23	22	19	15												
	kW	3.81	3.89	4.02	4.15	4.11	4.20	4.34	4.49	4.38	4.47	4.62	4.78	4.61	4.71	4.87	5.04	4.81	4.92	5.08	5.26	4.98	5.09	5.27	5.45												
	Amps	13.5	13.9	14.4	14.9	14.7	15.1	15.6	16.2	16.1	16.5	17.1	17.7	17.2	17.7	18.3	19.0	20.2	20.8	21.5	22.3	21.4	22.0	22.7	23.6												
	HI PR	236	254	258	263	259	279	283	289	304	327	331	339	346	372	377	386	389	419	424	434	450	484	490	501												
Lo PR	113	116	127	135	116	120	131	139	120	124	135	144	123	127	139	148	126	130	142	151	129	133	145	155													

2250	MBh	61.6	62.8	65.8	70.2	60.2	61.3	64.2	68.5	58.7	59.9	62.7	66.9	57.3	58.4	61.2	65.3	54.4	55.5	58.1	62.0	50.4	51.4	53.8	57.4
	S/T	0.96	0.92	0.83	0.68	0.99	0.96	0.86	0.70	1.00	0.98	0.89	0.72	1.00	1.00	0.91	0.74	1.00	1.00	0.95	0.77	1.00	1.00	0.96	0.78
	ΔT	24	24	22	19	24	24	23	20	24	24	23	20	23	24	23	20	22	23	23	20	21	21	21	18
	kW	3.87	3.96	4.09	4.22	4.18	4.27	4.41	4.56	4.45	4.55	4.70	4.86	4.69	4.80	4.96	5.13	4.89	5.00	5.17	5.35	5.07	5.18	5.36	5.55
	Amps	13.8	14.2	14.7	15.2	15.0	15.4	15.9	16.6	16.4	16.8	17.4	18.1	17.6	18.0	18.7	19.4	20.6	21.2	21.9	22.8	21.8	22.4	23.2	24.1
2000	HI PR	241	259	263	269	265	285	289	295	310	333	338	345	353	380	385	393	397	427	433	443	459	493	500	511
	Lo PR	115	119	130	138	118	122	133	142	123	126	138	147	126	130	142	151	128	132	144	154	131	136	148	158
	MBh	59.8	61.0	63.9	68.1	58.4	59.6	62.4	66.5	57.0	58.1	60.9	65.0	55.6	56.7	59.4	63.4	52.9	53.9	56.4	60.2	49.0	49.9	52.3	55.8
	S/T	0.91	0.88	0.80	0.65	0.95	0.91	0.82	0.67	0.97	0.94	0.85	0.69	1.00	0.97	0.87	0.71	1.00	1.00	0.91	0.73	1.00	1.00	0.91	0.74
	ΔT	25	25	23	20	25	25	24	20	25	25	24	21	26	25	24	21	24	25	23	20	23	23	22	19
1750	kW	3.84	3.93	4.05	4.19	4.15	4.24	4.38	4.52	4.41	4.51	4.66	4.82	4.65	4.75	4.91	5.08	4.85	4.96	5.13	5.31	5.02	5.14	5.31	5.50
	Amps	13.7	14.0	14.5	15.1	14.9	15.2	15.8	16.4	16.2	16.6	17.2	17.9	17.4	17.8	18.5	19.2	20.4	21.0	21.7	22.6	21.6	22.2	23.0	23.9
	HI PR	239	257	260	266	262	282	286	292	307	330	335	342	349	376	381	389	393	423	429	438	454	488	495	506
	Lo PR	114	118	128	137	117	121	132	141	121	125	137	145	125	128	140	149	127	131	143	152	130	134	147	156
	MBh	55.2	56.3	58.9	62.9	53.9	55.0	57.6	61.4	52.6	53.7	56.2	60.0	51.4	52.4	54.8	58.5	48.8	49.7	52.1	55.6	45.2	46.1	48.2	51.5
85	S/T	0.88	0.85	0.77	0.62	0.91	0.88	0.79	0.64	0.94	0.90	0.82	0.66	0.97	0.93	0.84	0.68	1.00	0.97	0.87	0.71	1.00	0.98	0.88	0.71
	ΔT	26	25	24	21	26	25	24	21	26	25	24	21	26	26	24	21	26	25	24	21	24	24	22	19
	kW	3.81	3.89	4.02	4.15	4.11	4.20	4.34	4.49	4.38	4.47	4.62	4.78	4.61	4.71	4.87	5.04	4.81	4.92	5.08	5.26	4.98	5.09	5.27	5.45
	Amps	13.5	13.9	14.4	14.9	14.7	15.1	15.6	16.2	16.1	16.5	17.1	17.7	17.2	17.7	18.3	19.0	20.2	20.8	21.5	22.3	21.4	22.0	22.7	23.6
	HI PR	236	254	258	263	259	279	283	289	304	327	331	339	346	372	377	386	389	419	424	434	450	484	490	501
Lo PR	113	116	127	135	116	120	131	139	120	124	135	144	123	127	139	148	126	130	142	151	129	133	145	155	

IDB = Entering Indoor Dry Bulb Temperature
 High and low pressures are measured at the liquid and suction service valves.
 Shaded area reflects AHRI (TVA) conditions
 kW = Total system power
 Amps = outdoor unit amps (comp.+fan)

OUTDOOR UNIT	INDOOR UNITS		COOLING RATINGS				CFM	AHRI #
	COILS/AIR HANDLERS	FURNACES	TOTAL ¹	SENS. ¹	SEER ²	EER ³		
DSXC18 0361A*	CHPF4860D6D*+TXV	A*VM960805CXB*	36,000	27,400	18.00	13.25	1,250	6497815
	CHPF3642D6C*+TXV	A*VM960805DXB*	35,000	26,600	18.00	13.25	1,250	6497781
	CA*F4961*6D*+TXV	G*EC961004CNA*	35,000	26,600	17.50	13.00	1,150	7366145
	CA*F3743*6D*+TXV	G*VM960805DXB*	35,000	26,600	18.00	13.25	1,250	5620886
	CA*F4961*6D*+TXV	A*VM960805CXB*	35,000	26,600	18.00	13.25	1,225	6497771
	CA*F4961*6D*+TXV	G*VM960604CXB*	35,000	26,600	17.50	13.30	1,225	5620870
	CHPF3743D6B*+TXV	G*VM961155DXB*	35,000	26,600	18.00	13.00	1,225	5620903
	CHPF3642C6C*+MBVC1600**-1A*+TXV		35,000	26,600	18.00	13.00	1,250	3654252
	CA*F4961*6D*+TXV	G*VM971205DNA*	34,800	26,400	17.50	13.00	1,150	7356702
	CSCF3642N6D*+TXV	G*VC950704CXB*	34,600	26,200	17.00	13.00	1,225	5620830
	CA*F4961*6D*+TXV	A*VC950915DXB*	35,000	26,600	18.00	13.50	1,225	5620855
	CA*F4961*6D*+TXV	G*VM970603BNA*	34,000	25,800	16.50	13.00	1,075	7356568
	CA*F3743*6D*+TXV	G*VM960805CXB*	35,000	26,600	18.00	13.25	1,200	5620879
	CHPF3743C6B*+TXV	G*VM961005DXB*	35,000	26,600	18.00	13.00	1,225	5620896
	CHPF3743C6B*+TXV	G*VM960805DXB*	35,000	26,600	18.00	13.25	1,250	5620890
	CSCF3642N6D*+TXV	G*VC951155DXB*	34,600	26,200	17.50	13.00	1,225	5620862
	CA*F3743*6D*+TXV	G*VM971205DNA*	34,600	26,200	17.00	13.00	1,150	7356701
	CA*F4961*6D*+TXV	G*VC960403BNA*	34,000	25,800	16.50	13.00	1,075	7356523
	CHPF3743C6B*+TXV	G*VM970803BNA*	34,000	25,800	16.50	13.00	1,100	7356575
	CHPF3743C6B*+TXV	G*VC960403BNA*	34,000	25,800	16.50	13.00	1,075	7356525
	CHPF3743C6B*+TXV	G*VC950704CXB*	35,000	26,600	17.50	13.00	1,275	5620827
	CHPF4860D6D*+TXV	G*VM961155DXB*	35,000	26,600	18.30	13.25	1,225	5620904
	CA*F3743*6D*+TXV	ADVC80805C*B*	35,000	26,600	17.00	13.00	1,190	5039119
	CHPF3642D6C*+TXV	A*VC951155DXB*	35,000	26,600	18.00	13.00	1,225	6497779
	CHPF4860D6D*+TXV	G*VM971005CNA*	34,600	26,200	17.50	13.00	1,175	7356585
	CHPF3743C6B*+TXV	A*VC80805C*B*	35,000	26,600	17.00	13.00	1,190	5038819
	CHPF3743C6B*+TXV	A*VC960603BNA*	34,000	25,800	16.50	13.00	1,075	7356615
	DV48PTCC14A*		34,000	25,800	16.00	12.50	1,100	7079243
	CAPT4961*4A*	A*VM970804CNA*	34,600	26,200	17.00	13.00	1,190	7356663
	CSCF3642N6D*+TXV	G*VC960803BNA*	34,000	25,800	16.50	13.00	1,100	7356536
	CHPF3743C6B*+TXV	G*VM960805CXB*	35,000	26,600	18.00	13.25	1,250	5620883
	CSCF3642N6D*+TXV	A*VM970603BNA*	34,000	25,800	16.50	13.00	1,075	7356656
	CHPF3642C6C*+TXV	G*VM960604CXB*	35,000	26,600	17.50	13.00	1,275	5620872
	CA*F3743*6D*+TXV	A*VM971005CNA*	34,400	26,200	17.00	13.00	1,175	7356714
	CSCF4860N6D*+TXV	G*VC961205DNA*	34,600	26,200	17.00	13.00	1,150	7356698
	CHPF3743D6B*+TXV	A*VC950905CXB*	35,000	26,600	18.00	13.25	1,250	6497799
	CA*F3743*6D*+MBVC1600**-1A*+TXV		35,000	26,600	18.00	13.00	1,200	4415028
	CHPF4860D6D*+TXV	G*VC961005CNA*	34,600	26,200	17.50	13.00	1,175	7356545
	CSCF3642N6D*+TXV	A*VC950453BXB*	34,600	26,200	17.00	13.00	1,200	6497820
	CHPF3743C6B*+TXV	A*VC960804CNA*	34,600	26,200	17.00	13.00	1,190	7356624
	CA*F3743*6D*+TXV	G*VM961005DXB*	35,000	26,600	18.00	13.00	1,225	5620893
	CHPF3642D6C*+TXV	G*VC951155DXB*	35,000	26,600	18.00	13.00	1,225	5620859
	CAPT4961*4A*	G*VC961005CNA*	34,600	26,200	17.00	13.00	1,175	7356543
	CA*F4961*6D*+MBVC2000**-1A*+TXV		36,000	27,400	19.00	13.50	1,250	4431666
	CHPF4860D6D*+TXV	A*VC950453BXB*	34,600	26,200	17.00	13.00	1,200	6497809
	CHPF3743C6B*+TXV	A*VM960805DXB*	35,000	26,600	18.00	13.25	1,250	6497792
	CHPF4860D6D*+TXV	A*VC951155DXB*	35,000	26,600	18.30	13.25	1,225	6497813
	CA*F4961*6D*+TXV	A*VC960403BNA*	34,000	25,800	16.50	13.00	1,075	7356608
	CHPF3743D6B*+TXV	G*VC950905CXB*	35,000	26,600	18.00	13.25	1,250	5620840
	CA*F3743*6D*+TXV	G*VM960604CXB*	35,000	26,600	17.50	13.00	1,250	5620868
CA*F3743*6D*+TXV	A*VM970803BNA*	33,600	25,600	16.00	13.00	1,100	7356657	
CHPF4860D6D*+TXV	A*VC950905CXB*	36,000	27,400	18.00	13.25	1,250	6497811	
CHPF3642D6C*+TXV	G*VM960805CXB*	35,000	26,600	18.00	13.25	1,250	5620882	
CHPF4860D6D*+TXV	A*VC961005CNA*	34,600	26,200	17.50	13.00	1,175	7356630	
CSCF3642N6D*+TXV	G*VC950453BXB*	34,600	26,200	17.00	13.00	1,200	5620823	
CAPT4961*4A*	G*VM970603BNA*	34,000	25,800	16.50	13.00	1,075	7356569	

See Notes on Page 25.

OUTDOOR UNIT	INDOOR UNITS		COOLING RATINGS				CFM	AHRI #
	COILS/AIR HANDLERS	FURNACES	TOTAL ¹	SENS. ¹	SEER ²	EER ³		
DSXC18 0361A* (cont.)	CAPT4961*4A*	A*VC961205DNA*	34,800	26,400	17.00	13.00	1,150	7356710
	CA*F3743*6D*+TXV	G*VC81005C*B*	35,000	26,600	17.00	13.00	1,210	6497758
	CA*F4961*6D*+TXV	G*VC960804CNA*	34,600	26,200	17.50	13.00	1,190	7356537
	CA*F4961*6D*+TXV	G*VC950453BXB*	35,000	26,600	17.00	13.00	1,200	5620819
	CA*F3743*6D*+TXV	A*VM971205DNA*	34,600	26,200	17.00	13.00	1,150	7356715
	CA*F4961*6D*+TXV	A*VM970603BNA*	34,000	25,800	16.50	13.00	1,075	7356653
	CHPF3743D6B*+TXV	A*VM960805CXB*	35,000	26,600	18.00	13.25	1,250	6497803
	CA*F4961*6D*+TXV	G*VC950704CXB*	35,000	26,600	17.50	13.30	1,225	5620825
	CHPF3743D6B*+TXV	A*VC951155DXB*	35,000	26,600	18.00	13.00	1,225	6497801
	CA*F4961*6D*+TXV	A*EC960603BNA*	35,000	26,600	17.00	13.00	1,150	7366158
	CSCF3642N6D*+TXV	A*VC960603BNA*	34,000	25,800	16.50	13.00	1,075	7356616
	CHPF4860D6D*+TXV	A*VC960804CNA*	34,600	26,200	17.50	13.00	1,190	7356625
	CA*F3743*6D*+TXV	G*VC961005CNA*	34,400	26,200	17.00	13.00	1,175	7356693
	CA*F3743*6D*+TXV	G*VM971005CNA*	34,400	26,200	17.00	13.00	1,175	7356700
	CA*F3743*6D*+TXV	A*VC80604B*B*	35,000	26,600	17.00	13.00	1,220	5038969
	CHPF3743C6B*+TXV	G*VC960804CNA*	34,600	26,200	17.00	13.00	1,190	7356539
	CA*F4860*6D*+MBVC2000**-1A*+TXV		36,000	27,400	19.00	13.50	1,250	6497759
	CHPF3743D6B*+TXV	G*VC80604B*B*	35,000	26,600	17.00	13.00	1,220	5038939
	CHPF3743C6B*+TXV	A*VC960403BNA*	34,000	25,800	16.50	13.00	1,075	7356610
	CHPF3743D6B*+TXV	G*VC950905DXB*	35,000	26,600	18.00	13.25	1,250	5620847
	CAPT4961*4A*	G*VM971005CNA*	34,600	26,200	17.00	13.00	1,175	7356583
	CAPT4961*4A*	A*VC960603BNA*	34,000	25,800	16.50	13.00	1,075	7356614
	CHPF4860D6D*+TXV	G*VC950905DXB*	36,000	27,400	18.00	13.25	1,250	5620848
	CA*F3743*6D*+TXV	G*VC961205DNA*	34,600	26,200	17.00	13.00	1,150	7356694
	CHPF3743C6B*+TXV	G*VM970804CNA*	34,600	26,200	17.00	13.00	1,190	7356579
	CAPT4961*4A*	A*VM970603BNA*	34,000	25,800	16.50	13.00	1,075	7356654
	CA*F4961*6D*+TXV	G*VM960805CXB*	35,000	26,600	18.00	13.25	1,225	5620881
	CA*F4961*6D*+TXV	A*VC950905DXB*	35,000	26,600	18.00	13.50	1,225	6497768
	CAPT4961*4A*	A*VM971005CNA*	34,600	26,200	17.00	13.00	1,175	7356668
	CHPF3743C6B*+TXV	G*VC80604B*B*	35,000	26,600	17.00	13.00	1,220	5039229
	CA*F4961*6D*+TXV	G*VC960603BNA*	34,000	25,800	16.50	13.00	1,075	7356528
	CA*F3743*6D*+TXV	G*VC950905DXB*	35,000	26,600	18.00	13.25	1,200	5620843
	CSCF4860N6D*+TXV	A*VM971205DNA*	34,600	26,200	17.00	13.00	1,150	7356719
	CA*F3743*6D*+TXV	G*VM970804CNA*	34,400	26,200	17.00	13.00	1,190	7356699
	CHPF3743C6B*+TXV	A*VM961005DXB*	35,000	26,600	18.00	13.00	1,225	6497793
	CSCF3642N6D*+TXV	A*VC961005CNA*	34,400	26,200	17.00	13.00	1,175	7356631
	CSCF3642N6D*+TXV	G*VC961005CNA*	34,400	26,200	17.00	13.00	1,175	7356546
	CA*F4961*6D*+TXV	G*VC81005C*B*	36,000	27,400	18.00	13.70	1,210	6497775
	CHPF3743C6B*+TXV	A*VC960803BNA*	34,000	25,800	16.50	13.00	1,100	7356620
	CHPF3743D6B*+TXV	G*VM960805CXB*	35,000	26,600	18.00	13.25	1,250	5620884
	CHPF3743C6B*+TXV	G*VC80805C*B*	35,000	26,600	17.00	13.00	1,190	5039016
	CSCF3642N6D*+TXV	G*VM970603BNA*	34,000	25,800	16.50	13.00	1,075	7356571
	CA*F3743*6D*+MBVC2000**-1A*+TXV		35,000	26,600	18.00	13.00	1,200	4415029
	CA*F3743*6D*+TXV	G*EC961004CNA*	34,000	25,800	17.00	13.00	1,150	7366144
	CA*F3743*6D*+TXV	G*VC960403BNA*	33,600	25,600	16.00	13.00	1,075	7356522
	CA*F4961*6D*+TXV	G*VC950714CXB*	35,000	26,600	17.50	13.30	1,225	5620834
	CSCF3642N6D*+TXV	A*VC960804CNA*	34,400	26,200	17.00	13.00	1,190	7356626
	CAPT4961*4A*	G*EC960803BNA*	35,000	26,600	17.00	12.50	1,150	7366142
	CA*F4961*6D*+TXV	G*VM970803BNA*	34,000	25,800	16.50	13.00	1,100	7356573
	CA*F3743*6D*+TXV	G*VC950905CXB*	35,000	26,600	18.00	13.25	1,200	5620835
CA*F3743*6D*+TXV	A*VC960804CNA*	34,400	26,200	17.00	13.00	1,190	7356706	
CHPF3743D6B*+TXV	A*VM960603BXB*	34,600	26,200	17.00	13.00	1,200	6497802	
CHPF3642C6C*+TXV	A*VM960604CXB*	35,000	26,600	17.50	13.00	1,275	5620871	
CA*F4961*6D*+TXV	G*VC950905DXB*	35,000	26,600	18.00	13.50	1,225	5620845	
CA*F4961*6D*+TXV	G*VC950915DXB*	35,000	26,600	18.00	13.50	1,225	5620856	
CA*F3743*6D*+TXV	G*VC91155DXA*	35,000	26,600	18.00	13.00	1,225	4415050	

See Notes on Page 25.

OUTDOOR UNIT	INDOOR UNITS		COOLING RATINGS				CFM	AHRI #
	COILS/AIR HANDLERS	FURNACES	TOTAL ¹	SENS. ¹	SEER ²	EER ³		
DSXC18 0361A* (cont.)	CA*F4860*6D*+TXV	G*VC950915DXB*	35,000	26,600	17.50	13.00	1,225	5620854
	CSCF3642N6D*+TXV	A*VC951155DXB*	34,600	26,200	17.50	13.00	1,225	6497824
	CHPF3743D6B*+TXV	G*VC80805C*B*	35,000	26,600	17.00	13.00	1,190	5038940
	CHPF3743C6B*+TXV	A*VC961005CNA*	34,600	26,200	17.00	13.00	1,175	7356629
	CA*F3743*6D*+TXV	A*VC950704CXB*	35,000	26,600	17.50	13.00	1,275	6497750
	CAPT4961*4A*	G*VC960603BNA*	34,000	25,800	16.50	13.00	1,075	7356529
	CHPF3743C6B*+TXV	A*VC80604B*B*	35,000	26,600	17.00	13.00	1,220	5039122
	CHPF3743C6B*+TXV	A*VM971005CNA*	34,600	26,200	17.00	13.00	1,175	7356669
	CHPF3743C6B*+TXV	A*VM960603BXB*	34,600	26,200	17.00	13.00	1,200	6497790
	CA*F3743*6D*+TXV	G*EC960603BNA*	34,000	25,800	16.00	13.00	1,150	7366136
	CHPF3642D6C*+TXV	G*VM960805DXB*	35,000	26,600	18.00	13.25	1,250	5620889
	CA*F3743*6D*+TXV	G*VM970803BNA*	33,600	25,600	16.00	13.00	1,100	7356572
	CHPF3743D6B*+TXV	G*VC951155DXB*	35,000	26,600	18.00	13.00	1,225	5620860
	CA*F4961*6D*+TXV	ADVC80805C*B*	36,000	27,400	18.00	13.70	1,190	5038968
	CSCF4860N6D*+EEP+TXV		36,000	27,400	15.00	12.50	1,250	5357213
	CA*F4961*6D*+TXV	G*VC961205DNA*	34,800	26,400	17.50	13.00	1,150	7356695
	CA*F3743*6D*+TXV	A*VC960803BNA*	33,600	25,600	16.00	13.00	1,100	7356617
	CHPF4860D6D*+TXV	G*VC960804CNA*	34,600	26,200	17.50	13.00	1,190	7356540
	CSCF3642N6D*+TXV	G*VC960603BNA*	34,000	25,800	16.50	13.00	1,075	7356531
	CAPT4961*4A*	G*VM970804CNA*	34,600	26,200	17.00	13.00	1,190	7356578
	CHPF4860D6D*+TXV	G*VM970804CNA*	34,600	26,200	17.50	13.00	1,190	7356580
	CA*F4860*6D*+TXV	G*VM960805DXB*	35,000	26,600	17.50	13.00	1,225	5620887
	CHPF4860D6D*+TXV	A*VM971205DNA*	34,800	26,400	17.50	13.00	1,150	7356718
	CSCF4860N6D*+TXV	G*VM971205DNA*	34,600	26,200	17.00	13.00	1,150	7356705
	CHPF3743D6B*+TXV	A*VM961005DXB*	35,000	26,600	18.00	13.00	1,225	6497805
	CHPF4860D6D*+TXV	A*VC950905DXB*	36,000	27,400	18.00	13.25	1,250	6497812
	CA*F4961*6D*+TXV	A*VC961005CNA*	34,600	26,200	17.50	13.00	1,175	7356627
	CHPF3743C6B*+TXV	A*VC950905CXB*	35,000	26,600	18.00	13.25	1,250	6497787
	CA*F4961*6D*+TXV	G*VC950905CXB*	35,000	26,600	18.00	13.25	1,225	5620837
	CA*F3743*6D*+TXV	A*VM960805CXB*	35,000	26,600	18.00	13.25	1,200	6497754
	CHPF3743C6B*+TXV	G*VM970603BNA*	34,000	25,800	16.50	13.00	1,075	7356570
	CHPF3743D6B*+TXV	G*VC81005C*B*	35,000	26,600	17.00	13.00	1,210	6497807
	CHPF4860D6D*+TXV	A*VM961005DXB*	35,000	26,600	18.30	13.25	1,225	6497817
	CHPF4860D6D*+TXV	G*VC950453BXB*	34,600	26,200	17.00	13.00	1,200	5620822
	CA*F3743*6D*+TXV	A*VC960403BNA*	33,600	25,600	16.00	13.00	1,075	7356607
	CHPF3642D6C*+TXV	A*VM960805CXB*	35,000	26,600	18.00	13.25	1,250	6497780
	CA*F4961*6D*+TXV	A*EC961004CNA*	35,000	26,600	17.50	13.00	1,150	7366166
	CSCF3642N6D*+TXV	G*VM970804CNA*	34,400	26,200	17.00	13.00	1,190	7356581
	CAPT4961*4A*	G*VC960803BNA*	34,000	25,800	16.50	13.00	1,100	7356534
	CA*F3743*6D*+TXV	G*VC951155DXB*	35,000	26,600	18.00	13.00	1,225	5620857
	CA*F4961*6D*+TXV	G*VC80805C*B*	36,000	27,400	18.00	13.70	1,190	5038816
	CSCF3642N6D*+TXV	A*VM970803BNA*	34,000	25,800	16.50	13.00	1,100	7356661
	CA*F4860*6D*+TXV	A*VC950915DXB*	35,000	26,600	17.50	13.00	1,225	5620853
	CA*F4961*6D*+TXV	G*VM961155DXB*	36,000	27,400	18.30	13.25	1,225	5620900
	CHPF3743C6B*+TXV	G*VM960603BXB*	34,600	26,200	17.00	13.00	1,200	5620864
	CA*F4961*6D*+TXV	G*EC960603BNA*	35,000	26,600	17.00	13.00	1,150	7366137
	CSCF3642N6D*+TXV	A*VC950905CXB*	34,600	26,200	17.50	13.00	1,150	6497822
	CAPT4961*4A*	G*EC960603BNA*	35,000	26,600	17.00	13.00	1,150	7366138
	CA*F4961*6D*+TXV	A*VC950704CXB*	35,000	26,600	17.50	13.30	1,225	6497766
	CHPF3743D6B*+TXV	A*VC950704CXB*	34,600	26,200	17.00	13.00	1,225	6497798
CHPF4860D6D*+TXV	G*VM960603BXB*	34,600	26,200	17.00	13.00	1,200	5620866	
AVPTC48D14A*		36,000	27,400	17.50	13.00	1,200	5924368	
CHPF3743C6B*+TXV	G*VC960603BNA*	34,000	25,800	16.50	13.00	1,075	7356530	
CHPF4860D6D*+MBVC2000**-1A*+TXV		35,000	26,600	18.30	13.00	1,250	3654297	
CA*F4860*6D*+TXV	A*VC950905DXB*	35,000	26,600	17.50	13.00	1,225	6497761	
CSCF3642N6D*+TXV	G*VC960804CNA*	34,400	26,200	17.00	13.00	1,190	7356541	

See Notes on Page 25.

OUTDOOR UNIT	INDOOR UNITS		COOLING RATINGS				CFM	AHRI #
	COILS/AIR HANDLERS	FURNACES	TOTAL ¹	SENS. ¹	SEER ²	EER ³		
DSXC18 0361A* (cont.)	CSCF3642N6D*+TXV	G*VM971005CNA*	34,400	26,200	17.00	13.00	1,175	7356586
	CA*F3743*6D*+TXV	G*EC960803BNA*	34,000	25,800	16.00	12.50	1,150	7366140
	CSCF3642N6D*+TXV	A*VC960803BNA*	34,000	25,800	16.50	13.00	1,100	7356621
	CA*F4961*6D*+TXV	A*VC81005C*B*	36,000	27,400	18.00	13.70	1,210	6497764
	CA*F3743*6D*+TXV	A*EC961004CNA*	34,000	25,800	17.00	13.00	1,150	7366165
	CSCF3642N6D*+TXV	A*VM971005CNA*	34,400	26,200	17.00	13.00	1,175	7356671
	CHPF3743C6B*+TXV	G*VC950905CXB*	35,000	26,600	18.00	13.25	1,250	5620839
	CHPF3743C6B*+MBVC1600**-1A*+TXV		35,000	26,600	18.00	13.00	1,250	3654262
	CHPF4860D6D*+TXV	A*VC81005C*B*	36,000	27,400	18.00	13.70	1,210	6497808
	AVPTC48C14A*		34,000	25,800	16.00	12.50	1,100	7079242
	CHPF3743D6B*+TXV	A*VC81005C*B*	35,000	26,600	17.00	13.00	1,210	6497796
	CHPF3743C6B*+TXV	A*VC81005C*B*	35,000	26,600	17.00	13.00	1,210	6497784
	CAPT4961*4A*	A*VM970803BNA*	34,000	25,800	16.50	13.00	1,100	7356659
	CHPF3743D6B*+TXV	G*VM961005DXB*	35,000	26,600	18.00	13.00	1,225	5620897
	CHPF3743C6B*+TXV	A*VM961155DXB*	35,000	26,600	18.00	13.00	1,225	6497794
	CA*F4961*6D*+TXV	A*VM960603BXB*	35,000	26,600	17.00	13.00	1,200	6497770
	CHPF3642D6C*+TXV	G*VM961005DXB*	35,000	26,600	18.00	13.00	1,225	5620895
	CSCF3642N6D*+TXV	A*VM970804CNA*	34,400	26,200	17.00	13.00	1,190	7356666
	CA*F4860*6D*+TXV	G*VC950905DXB*	35,000	26,600	17.50	13.00	1,225	5620844
	CA*F3743*6D*+TXV	A*VM960604CXB*	35,000	26,600	17.50	13.00	1,275	5620867
	CHPF3642C6C*+TXV	A*VC950704CXB*	35,000	26,600	17.50	13.00	1,275	6497776
	CHPF4860D6D*+TXV	A*VM971005CNA*	34,600	26,200	17.50	13.00	1,175	7356670
	CHPF4860D6D*+TXV	A*VC80805C*B*	36,000	27,400	18.00	13.70	1,190	5038970
	CHPF4860D6D*+TXV	G*VM960604CXB*	35,000	26,600	17.50	13.30	1,225	5620878
	CA*F4961*6D*+MBVC1600**-1A*+TXV		36,000	27,400	17.50	13.00	1,200	4431665
	CHPF4860D6D*+TXV	G*VM960805CXB*	36,000	27,400	18.00	13.25	1,250	5620885
	CA*F3743*6D*+TXV	A*EC960803BNA*	34,000	25,800	16.00	12.50	1,150	7366161
	CAPT4961*4A*	G*VC961205DNA*	34,800	26,400	17.00	13.00	1,150	7356696
	CHPF3743C6B*+TXV	G*VC961005CNA*	34,600	26,200	17.00	13.00	1,175	7356544
	CHPF4860D6D*+TXV	G*VC961205DNA*	34,800	26,400	17.50	13.00	1,150	7356697
	CA*F3743*6D*+TXV	G*VC960804CNA*	34,400	26,200	17.00	13.00	1,190	7356692
	CA*F3743*6D*+TXV	A*VC950905CXB*	35,000	26,600	18.00	13.25	1,200	6497751
	CHPF4860D6D*+TXV	G*VC80805C*B*	36,000	27,400	18.00	13.70	1,190	5039107
	CA*F4961*6D*+TXV	A*VM971205DNA*	34,800	26,400	17.50	13.00	1,150	7356716
	CSCF3642N6D*+TXV	G*VC950905DXB*	34,600	26,200	17.50	13.00	1,150	5620850
	CHPF3743D6B*+TXV	G*VM960805DXB*	35,000	26,600	18.00	13.25	1,250	5620891
	CA*F4961*6D*+TXV	A*VC960804CNA*	34,600	26,200	17.50	13.00	1,190	7356622
	CAPT4961*4A*	A*EC960803BNA*	35,000	26,600	17.00	12.50	1,150	7366163
	CHPF3743C6B*+TXV	A*VC950905DXB*	35,000	26,600	18.00	13.25	1,250	6497788
	CHPF3642C6C*+TXV	G*VC950704CXB*	35,000	26,600	17.50	13.00	1,275	5620826
	CHPF4860D6D*+TXV	G*VC951155DXB*	35,000	26,600	18.30	13.25	1,225	5620861
	CHPF4860D6D*+TXV	A*VC80604B*B*	36,000	27,400	17.50	13.20	1,220	5039017
	CAPT4961*4A*	A*VC961005CNA*	34,600	26,200	17.00	13.00	1,175	7356628
	CHPF4860D6D*+TXV	G*VM971205DNA*	34,800	26,400	17.50	13.00	1,150	7356704
	CA*F4961*6D*+TXV	A*VC80805C*B*	36,000	27,400	18.00	13.70	1,190	5038942
	CHPF3743C6B*+TXV	G*VM961155DXB*	35,000	26,600	18.00	13.00	1,225	5620902
	CA*F3743*6D*+TXV	G*VC950704CXB*	35,000	26,600	17.50	13.00	1,250	5620824
	CA*F4860*6D*+TXV	A*VM960805DXB*	35,000	26,600	17.50	13.00	1,225	6497763
	CHPF3743C6B*+TXV	A*EC960803BNA*	34,000	25,800	16.50	12.50	1,150	7366164
	CAPT4961*4A*	A*EC960603BNA*	35,000	26,600	17.00	13.00	1,150	7366159
	CA*F3743*6D*+TXV	A*EC960603BNA*	34,000	25,800	16.00	13.00	1,150	7366157
	CHPF3743C6B*+TXV	G*VM971005CNA*	34,600	26,200	17.00	13.00	1,175	7356584
	CA*F4961*6D*+TXV	G*VC961005CNA*	34,600	26,200	17.50	13.00	1,175	7356542
	CHPF3743D6B*+TXV	A*VC80604B*B*	35,000	26,600	17.00	13.00	1,220	5038943
	CA*F3743*6D*+TXV	G*VC960603BNA*	33,600	25,600	16.00	13.00	1,075	7356527
	CHPF3743C6B*+TXV	A*VC950453BXB*	34,600	26,200	17.00	13.00	1,200	6497785

See Notes on Page 25.

OUTDOOR UNIT	INDOOR UNITS		COOLING RATINGS				CFM	AHRI #
	COILS/AIR HANDLERS	FURNACES	TOTAL ¹	SENS. ¹	SEER ²	EER ³		
DSXC18 0361A* (cont.)	CSCF3642N6D*+TXV	G*VC950905CXB*	34,600	26,200	17.50	13.00	1,150	5620842
	CA*F4961*6D*+TXV	G*VC80604B*B*	36,000	27,400	17.50	13.20	1,220	5039228
	CHPF3743C6B*+TXV	G*EC960803BNA*	34,000	25,800	16.50	12.50	1,150	7366143
	CA*F3743*6D*+TXV	A*VC80805C*B*	35,000	26,600	17.00	13.00	1,190	5038941
	CHPF4860D6D*+TXV	A*VM960603BXB*	34,600	26,200	17.00	13.00	1,200	6497814
	CHPF3743C6B*+TXV	G*EC960603BNA*	34,000	25,800	16.50	13.00	1,150	7366139
	CHPF3743D6B*+TXV	A*VM960604CXB*	34,600	26,200	17.00	13.00	1,225	5620875
	CA*F4961*6D*+TXV	G*VC960803BNA*	34,000	25,800	16.50	13.00	1,100	7356533
	CA*F4860*6D*+TXV	A*VM960805CXB*	35,000	26,600	17.50	13.00	1,225	6497762
	CA*F4961*6D*+TXV	A*VC950714CXB*	35,000	26,600	17.50	13.30	1,225	5620833
	CA*F4961*6D*+TXV	G*EC960803BNA*	35,000	26,600	17.00	12.50	1,150	7366141
	CA*F4860*6D*+TXV	A*VC950905CXB*	35,000	26,600	17.50	13.00	1,225	6497760
	CSCF3642N6D*+TXV	A*VC960403BNA*	34,000	25,800	16.50	13.00	1,075	7356611
	CA*F4961*6D*+TXV	ADVC81005C*B*	36,000	27,400	18.00	13.70	1,230	6497774
	CA*F4961*6D*+TXV	G*VM961005DXB*	36,000	27,400	18.30	13.25	1,225	5620894
	CHPF4860D6D*+TXV	A*VC950704CXB*	35,000	26,600	17.50	13.30	1,225	6497810
	CHPF3743D6B*+TXV	A*VM960805DXB*	35,000	26,600	18.00	13.25	1,250	6497804
	CHPF3743C6B*+TXV	A*VM970804CNA*	34,600	26,200	17.00	13.00	1,190	7356664
	CA*F4961*6D*+TXV	A*VC80604B*B*	36,000	27,400	17.50	13.20	1,220	5038818
	CA*F3743*6D*+TXV	A*VC961205DNA*	34,600	26,200	17.00	13.00	1,150	7356708
	CHPF3743C6B*+TXV	A*EC961004CNA*	34,000	25,800	17.00	12.50	1,150	7366168
	CA*F4860*6D*+TXV	G*VM960805CXB*	35,000	26,600	17.50	13.00	1,225	5620880
	CA*F3743*6D*+TXV	A*VC951155DXB*	35,000	26,600	18.00	13.00	1,225	6497753
	CSCF4860N6D*+TXV	A*VC961205DNA*	34,600	26,200	17.00	13.00	1,150	7356712
	CHPF3642D6C*+TXV	G*VC950905CXB*	35,000	26,600	18.00	13.25	1,250	5620838
	CSCF3642N6D*+TXV	G*VM970803BNA*	34,000	25,800	16.50	13.00	1,100	7356576
	CA*F3743*6D*+TXV	A*VC950714CXB*	35,000	26,600	17.50	13.00	1,275	5620831
	CHPF4860D6D*+TXV	A*VM961155DXB*	35,000	26,600	18.30	13.25	1,225	6497818
	CHPF3743C6B*+TXV	A*VM970803BNA*	34,000	25,800	16.50	13.00	1,100	7356660
	CA*F3743*6D*+TXV	G*VC80604B*B*	35,000	26,600	17.00	13.00	1,220	5038845
	CA*F3743*6D*+TXV	A*VM961005DXB*	35,000	26,600	18.00	13.00	1,225	6497755
	CA*F3743*6D*+TXV	A*VC960603BNA*	33,600	25,600	16.00	13.00	1,075	7356612
	CHPF3743C6B*+TXV	G*VC950453BXB*	34,600	26,200	17.00	13.00	1,200	5620820
	CA*F4961*6D*+TXV	A*VC950905CXB*	35,000	26,600	18.00	13.25	1,225	6497767
	CA*F3743*6D*+TXV	G*VC950915DXB*	35,000	26,600	18.00	13.25	1,250	5620852
	CA*F4961*6D*+TXV	A*EC960803BNA*	35,000	26,600	17.00	12.50	1,150	7366162
	CHPF3743D6B*+TXV	A*VC80805C*B*	35,000	26,600	17.00	13.00	1,190	5039108
	CHPF4860D6D*+TXV	A*VM960604CXB*	35,000	26,600	17.50	13.30	1,225	5620877
	CA*F3743*6D*+TXV	A*VM970603BNA*	33,600	25,600	16.00	13.00	1,075	7356652
	CAPT4961*4A*	G*VC960804CNA*	34,600	26,200	17.00	13.00	1,190	7356538
	CHPF4860D6D*+TXV	A*VC961205DNA*	34,800	26,400	17.50	13.00	1,150	7356711
	CHPF3743C6B*+TXV	G*VC81005C*B*	35,000	26,600	17.00	13.00	1,210	6497795
	CA*F4961*6D*+TXV	G*VM971005CNA*	34,600	26,200	17.50	13.00	1,175	7356582
	CA*F4961*6D*+TXV	A*VC950453BXB*	35,000	26,600	17.00	13.00	1,200	6497765
	AVPTC42D14A*		35,000	26,600	17.00	13.00	1,280	5924367
	CHPF3743C6B*+TXV	A*VM960604CXB*	35,000	26,600	17.50	13.00	1,275	5620873
	CA*F3743*6D*+TXV	A*VM970804CNA*	34,400	26,200	17.00	13.00	1,190	7356713
	CHPF4860D6D*+TXV	G*VC950905CXB*	36,000	27,400	18.00	13.25	1,250	5620841
	CA*F3743*6D*+TXV	A*VC950905DXB*	35,000	26,600	18.00	13.25	1,250	6497752
	CHPF3642D6C*+MBVC2000**-1A*+TXV		35,000	26,600	18.00	13.00	1,250	3654256
	CA*F4961*6D*+TXV	A*VM970803BNA*	34,000	25,800	16.50	13.00	1,100	7356658
	CA*F4961*6D*+EEP+TXV		36,000	27,400	15.00	12.50	1,250	5357211
	CAPT4961*4A*	G*VM970803BNA*	34,000	25,800	16.50	13.00	1,100	7356574
	CHPF3743D6B*+MBVC2000**-1A*+TXV		35,000	26,600	18.00	13.00	1,250	3654277
	CHPF4860D6D*+TXV	G*VM960805DXB*	36,000	27,400	18.00	13.25	1,250	5620892
	CA*F4961*6D*+TXV	A*VM961155DXB*	36,000	27,400	18.30	13.25	1,225	6497773
	CA*F4961*6D*+TXV	A*VM970804CNA*	34,600	26,200	17.50	13.00	1,190	7356662
	CHPF4860D6D*+EEP+TXV		36,000	27,400	15.00	12.50	1,250	5357212
	CHPF4860D6D*+TXV	G*VC80604B*B*	36,000	27,400	17.50	13.20	1,220	5038846

See Notes on Page 25.

OUTDOOR UNIT	INDOOR UNITS		COOLING RATINGS				CFM	AHRI #
	COILS/AIR HANDLERS	FURNACES	TOTAL ¹	SENS. ¹	SEER ²	EER ³		
DSXC18 0361A* (cont.)	CA*F4961*6D*+TXV	A*VM971005CNA*	34,600	26,200	17.50	13.00	1,175	7356667
	CHPF3743D6B*+TXV	G*VC950704CXB*	34,600	26,200	17.00	13.00	1,225	5620828
	CHPF3642D6C*+TXV	A*VC950905DXB*	35,000	26,600	18.00	13.25	1,250	6497778
	CHPF3743D6B*+TXV	A*VM961155DXB*	35,000	26,600	18.00	13.00	1,225	6497806
	CHPF4860D6D*+TXV	G*VM961005DXB*	35,000	26,600	18.30	13.25	1,225	5620898
	CAPT4961*4A*	G*VC960403BNA*	34,000	25,800	16.50	13.00	1,075	7356524
	CSCF3642N6D*+TXV	A*VC950704CXB*	34,600	26,200	17.00	13.00	1,225	6497821
	CAPT4961*4A*	G*EC961004CNA*	35,000	26,600	17.00	13.00	1,150	7366146
	CA*F4961*6D*+TXV	A*VM961005DXB*	36,000	27,400	18.30	13.25	1,225	6497772
	CA*F4860*6D*+TXV	G*VC950905CXB*	35,000	26,600	17.50	13.00	1,225	5620836
	CA*F3743*6D*+TXV	A*VC950915DXB*	35,000	26,600	18.00	13.25	1,250	5620851
	CA*F3743*6D*+TXV	A*VC961005CNA*	34,400	26,200	17.00	13.00	1,175	7356707
	CA*F4961*6D*+TXV	A*VC961205DNA*	34,800	26,400	17.50	13.00	1,150	7356709
	CHPF3743D6B*+TXV	G*VM960604CXB*	34,600	26,200	17.00	13.00	1,225	5620876
	CA*F3743*6D*+TXV	G*VC80805C*B*	35,000	26,600	17.00	13.00	1,190	5038938
	CHPF3642D6C*+TXV	A*VM961005DXB*	35,000	26,600	18.00	13.00	1,225	6497782
	CHPF4860D6D*+TXV	G*VC950704CXB*	35,000	26,600	17.50	13.30	1,225	5620829
	CA*F4961*6D*+TXV	G*VM970804CNA*	34,600	26,200	17.50	13.00	1,190	7356577
	CA*F4961*6D*+TXV	G*VM960805DXB*	35,000	26,600	18.00	13.50	1,225	5620888
	CHPF4860D6D*+TXV	A*VM960805DXB*	36,000	27,400	18.00	13.25	1,250	6497816
	CHPF3743C6B*+TXV	G*VC960803BNA*	34,000	25,800	16.50	13.00	1,100	7356535
	CHPF4860D6D*+TXV	G*VC81005C*B*	36,000	27,400	18.00	13.70	1,210	6497819
	CHPF3743C6B*+TXV	A*VC950704CXB*	35,000	26,600	17.50	13.00	1,275	6497786
	CA*F3743*6D*+TXV	G*VM961155DXB*	35,000	26,600	18.00	13.00	1,225	5620899
	CA*F4961*6D*+TXV	A*VC951155DXB*	36,000	27,400	18.30	13.25	1,225	6497769
	CA*F3743*6D*+TXV	A*VC81005C*B*	35,000	26,600	17.00	13.00	1,210	6497749
	CAPT4961*4A*	A*VC960804CNA*	34,600	26,200	17.00	13.00	1,190	7356623
	CAPT4961*4A*	A*VC960803BNA*	34,000	25,800	16.50	13.00	1,100	7356619
	CHPF3743C6B*+TXV	G*EC961004CNA*	34,000	25,800	17.00	12.50	1,150	7366147
	CAPT4961*4A*	A*VC960403BNA*	34,000	25,800	16.50	13.00	1,075	7356609
	CAPT4961*4A*	A*VM971205DNA*	34,800	26,400	17.00	13.00	1,150	7356717
	CHPF3743C6B*+TXV	A*VM970603BNA*	34,000	25,800	16.50	13.00	1,075	7356655
	CHPF3743C6B*+TXV	A*EC960603BNA*	34,000	25,800	16.50	13.00	1,150	7366160
	CAPT4961*4A*	A*EC961004CNA*	35,000	26,600	17.00	13.00	1,150	7366167
	CHPF3743C6B*+TXV	A*VM960805CXB*	35,000	26,600	18.00	13.25	1,250	6497791
	CHPF3743C6B*+TXV	G*VM960604CXB*	35,000	26,600	17.50	13.00	1,275	5620874
	CA*F4961*6D*+TXV	A*VM960604CXB*	35,000	26,600	17.50	13.30	1,225	5620869
	CHPF3743D6B*+TXV	A*VC950905DXB*	35,000	26,600	18.00	13.25	1,250	6497800
	CHPF3743D6B*+TXV	G*VC950453BXB*	34,600	26,200	17.00	13.00	1,200	5620821
	CHPF3642D6C*+TXV	A*VM961155DXB*	35,000	26,600	18.00	13.00	1,225	6497783
	CSCF3642N6D*+TXV	A*VC950905DXB*	34,600	26,200	17.50	13.00	1,150	6497823
	CHPF3743D6B*+TXV	G*VM960603BXB*	34,600	26,200	17.00	13.00	1,200	5620865
	CA*F3743*6D*+TXV	G*VM970603BNA*	33,600	25,600	16.00	13.00	1,075	7356567
	CSCF3642N6D*+TXV	G*VC960403BNA*	34,000	25,800	16.50	13.00	1,075	7356526
	CA*F3743*6D*+TXV	A*VM961155DXB*	35,000	26,600	18.00	13.00	1,225	6497756
	CA*F4961*6D*+TXV	G*VM960603BXB*	35,000	26,600	17.00	13.00	1,200	5620863
	CA*F4961*6D*+TXV	A*VC960603BNA*	34,000	25,800	16.50	13.00	1,075	7356613
	CHPF3743D6B*+TXV	A*VC950453BXB*	34,600	26,200	17.00	13.00	1,200	6497797
	CA*F4961*6D*+TXV	G*VC951155DXB*	36,000	27,400	18.30	13.25	1,225	5620858
	CA*F3743*6D*+TXV	G*VC950714CXB*	35,000	26,600	17.50	13.00	1,250	5620832
	CA*F3743*6D*+TXV	ADVC81005C*B*	35,000	26,600	17.00	13.00	1,230	6497757
	CA*F4961*6D*+TXV	A*VC960803BNA*	34,000	25,800	16.50	13.00	1,100	7356618
	CHPF3642D6C*+TXV	A*VC950905CXB*	35,000	26,600	18.00	13.25	1,250	6497777
	CA*F3743*6D*+TXV	G*VC960803BNA*	33,600	25,600	16.00	13.00	1,100	7356532
	CHPF3642D6C*+TXV	G*VM961155DXB*	35,000	26,600	18.00	13.00	1,225	5620901
	CAPT4961*4A*	G*VM971205DNA*	34,800	26,400	17.00	13.00	1,150	7356703
	CHPF3642D6C*+TXV	G*VC950905DXB*	35,000	26,600	18.00	13.25	1,250	5620846
	CHPF4860D6D*+TXV	A*VM970804CNA*	34,600	26,200	17.50	13.00	1,190	7356665
	CHPF3743C6B*+TXV	A*VC951155DXB*	35,000	26,600	18.00	13.00	1,225	6497789
	CA*F3743*6D*+EEP+TXV		35,000	26,600	15.00	12.50	1,250	5357210

See Notes on Page 25.

OUTDOOR UNIT	INDOOR UNITS		COOLING RATINGS				CFM	AHRI #
	COILS/AIR HANDLERS	FURNACES	TOTAL ¹	SENS. ¹	SEER ²	EER ³		
DSXC18 0481A*	CSCF4860N6D*+TXV	A*VC960804CNA*	45,000	34,200	16.50	12.80	1,525	7356635
	CHPF4860D6D*+TXV	A*VM970804CNA*	45,500	34,600	17.00	12.80	1,525	7356674
	CAPT4961*4A*	A*EC961004CNA*	45,500	34,600	17.00	13.00	1,550	7366170
	CAPT4961*4A*	A*VM971205DNA*	46,000	35,000	17.50	12.80	1,530	7356681
	CA*F4961*6D*+TXV	A*VC960804CNA*	45,500	34,600	17.00	12.80	1,525	7356632
	CA*F4961*6D*+TXV	A*VM961005DXB*	47,500	36,200	18.00	13.00	1,600	6497831
	CA*F4961*6D*+TXV	A*VC951155DXB*	47,500	36,200	18.00	13.00	1,600	6497829
	CHPF4860D6D*+TXV	G*VC961205DNA*	46,000	35,000	17.50	12.80	1,530	7356557
	CA*F4961*6D*+TXV	G*VC961005CNA*	45,500	34,600	17.00	12.80	1,520	7356551
	CHPF4860D6D*+TXV	G*VC81005C*B*	48,000	36,400	17.00	12.20	1,520	6497843
	CA*F4961*6D*+TXV	ADVC80805C*B*	48,000	36,400	17.00	12.80	1,580	5039231
	CHPF4860D6D*+TXV	G*VM960805DXB*	47,000	35,800	17.50	13.00	1,750	5620920
	CAPT4961*4A*	G*EC961004CNA*	45,500	34,600	17.00	13.00	1,550	7366149
	CA*F4961*6D*+TXV	G*VC951155DXB*	47,000	35,800	18.00	13.00	1,750	5620912
	CAPT4961*4A*	G*EC961205DNA*	45,500	34,600	17.00	13.00	1,550	7366152
	CA*F4961*6D*+TXV	G*VM961005DXB*	47,000	35,800	18.00	13.00	1,750	5620921
	CAPT4961*4A*	A*VC961005CNA*	45,500	34,600	17.00	12.80	1,520	7356637
	CHPF4860D6D*+TXV	G*VM971205DNA*	46,000	35,000	17.50	12.80	1,530	7356597
	CSCF4860N6D*+TXV	G*VM970804CNA*	45,000	34,200	16.50	12.80	1,525	7356590
	CA*F4961*6D*+MBVC2000**-1A*+TXV		47,500	36,200	18.00	13.25	1,750	4431668
	CA*F4961*6D*+TXV	G*VM970804CNA*	45,500	34,600	17.00	12.80	1,525	7356587
	CA*F4961*6D*+TXV	A*VM971005CNA*	45,500	34,600	17.00	12.80	1,520	7356676
	CA*F4961*6D*+TXV	A*VC950905DXB*	47,000	35,800	17.50	13.00	1,750	6497828
	DV48PTCC14A*		45,000	34,200	16.00	12.00	1,450	7079245
	CAPT4961*4A*	A*VM971005CNA*	45,500	34,600	17.00	12.80	1,520	7356677
	CA*F4961*6D*+TXV	A*VC961005CNA*	45,500	34,600	17.00	12.80	1,520	7356636
	CA*F4961*6D*+TXV	G*VM961155DXB*	47,000	35,800	18.00	13.00	1,750	5620923
	AVPTC48C14A*		45,000	34,200	16.00	12.00	1,450	7079244
	CHPF4860D6D*+TXV	A*VC81005C*B*	48,000	36,400	17.00	12.20	1,520	6497835
	CSCF4860N6D*+TXV	A*VM970804CNA*	45,000	34,200	16.50	12.80	1,525	7356675
	CA*F4961*6D*+TXV	A*VM961155DXB*	47,500	36,200	18.00	13.00	1,600	6497832
	CHPF4860D6D*+TXV	A*VC80805C*B*	48,000	36,400	17.00	12.80	1,590	5038820
	CA*F4961*6D*+TXV	G*VM960604CXB*	46,000	35,000	17.00	13.00	1,725	5620915
	CHPF4860D6D*+TXV	A*EC961205DNA*	45,500	34,600	17.00	13.00	1,550	7366174
	CA*F4961*6D*+TXV	A*VM971205DNA*	46,000	35,000	17.50	12.80	1,530	7356680
	CHPF4860D6D*+TXV	A*EC961004CNA*	45,500	34,600	17.00	13.00	1,550	7366171
	CA*F4961*6D*+TXV	A*EC961004CNA*	45,500	34,600	17.00	13.00	1,550	7366169
	CA*F4961*6D*+TXV	G*VM971205DNA*	46,000	35,000	17.50	12.80	1,530	7356595
	CAPT4961*4A*	A*VC961205DNA*	46,000	35,000	17.50	12.80	1,530	7356641
	CHPF4860D6D*+TXV	G*VM960604CXB*	46,000	35,000	17.00	13.00	1,725	5620917
	CA*F4961*6D*+TXV	G*VM971005CNA*	45,500	34,600	17.00	12.80	1,520	7356591
	CAPT4961*4A*	G*VC961205DNA*	46,000	35,000	17.50	12.80	1,530	7356556
	CA*F4961*6D*+TXV	G*EC961205DNA*	45,500	34,600	17.00	13.00	1,550	7366151
	CAPT4961*4A*	A*EC961205DNA*	45,500	34,600	17.00	13.00	1,550	7366173
	CHPF4860D6D*+TXV	G*VC950905CXB*	47,000	35,800	16.50	13.00	1,750	5620907
	CA*F4961*6D*+TXV	G*EC961004CNA*	45,500	34,600	17.00	13.00	1,550	7366148
	CAPT4961*4A*	A*VC960804CNA*	45,500	34,600	17.00	12.80	1,525	7356633
	CHPF4860D6D*+EEP+TXV		48,000	36,400	15.50	12.50	1,500	5357215
	CHPF4860D6D*+TXV	A*VC950905CXB*	47,000	35,800	16.50	13.00	1,750	6497836
	CSCF4860N6D*+TXV	G*VM971005CNA*	45,000	34,200	16.50	12.80	1,520	7356594
CHPF4860D6D*+TXV	A*VM961005DXB*	47,500	36,200	18.00	13.00	1,600	6497841	
CAPT4961*4A*	G*VC961005CNA*	45,500	34,600	17.00	12.80	1,520	7356552	
CHPF4860D6D*+TXV	A*VM960805CXB*	47,000	35,800	16.50	13.00	1,750	6497839	
CA*F4961*6D*+TXV	G*VC81005C*B*	48,000	36,400	17.00	12.20	1,520	6497834	
CSCF4860N6D*+TXV	A*VC961205DNA*	45,500	34,600	17.00	12.80	1,530	7356643	
AVPTC48D14A*		47,000	35,800	17.50	13.00	1,700	5924369	
CA*F4961*6D*+TXV	A*VC81005C*B*	48,000	36,400	17.00	12.20	1,520	6497826	
CHPF4860D6D*+TXV	A*VC960804CNA*	45,500	34,600	17.00	12.80	1,525	7356634	

See Notes on Page 25.

OUTDOOR UNIT	INDOOR UNITS		COOLING RATINGS				CFM	AHRI #
	COILS/AIR HANDLERS	FURNACES	TOTAL ¹	SENS. ¹	SEER ²	EER ³		
DSXC18 0481A* (cont.)	CHPF4860D6D*+TXV	G*VC960804CNA*	45,500	34,600	17.00	12.80	1,525	7356549
	CSCF4860N6D*+TXV	G*VC961005CNA*	45,000	34,200	16.50	12.80	1,520	7356554
	CAPT4961*4A*	G*VC960804CNA*	45,500	34,600	17.00	12.80	1,525	7356548
	CA*F4961*6D*+TXV	G*VC950714CXB*	46,000	35,000	17.00	13.00	1,725	5620906
	CA*F4961*6D*+TXV	G*VC91155DXA*	46,500	35,400	16.50	13.00	1,650	4431743
	CHPF4860D6D*+TXV	G*VC80805C*B*	48,000	36,400	17.00	12.80	1,590	5039018
	CA*F4961*6D*+TXV	A*VC950915DXB*	47,000	35,800	17.50	13.00	1,750	5620910
	CA*F4961*6D*+TXV	A*VM960604CXB*	46,000	35,000	17.00	13.00	1,725	5620914
	CA*F4860*6D*+EEP+TXV		47,000	35,800	15.00	12.00	1,500	6497825
	CA*F4961*6D*+TXV	A*VC961205DNA*	46,000	35,000	17.50	12.80	1,530	7356640
	CA*F4961*6D*+TXV	A*VM970804CNA*	45,500	34,600	17.00	12.80	1,525	7356672
	CA*F4961*6D*+TXV	G*VC950905DXB*	47,000	35,800	17.50	13.00	1,750	5620908
	CHPF4860D6D*+TXV	G*VC961005CNA*	45,500	34,600	17.00	12.80	1,520	7356553
	CSCF4860N6D*+TXV	A*VM971205DNA*	45,500	34,600	17.00	12.80	1,530	7356683
	CHPF4860D6D*+TXV	G*VC950905DXB*	47,000	35,800	17.50	13.00	1,750	5620909
	CA*F4961*6D*+TXV	G*VC950915DXB*	47,000	35,800	17.50	13.00	1,750	5620911
	CA*F4961*6D*+TXV	A*VC80805C*B*	48,000	36,400	17.00	12.80	1,590	5038944
	CA*F4961*6D*+MBVC1600**-1A*+TXV		46,000	35,000	17.00	13.00	1,725	4431667
	CSCF4860N6D*+TXV	G*VC961205DNA*	45,500	34,600	17.00	12.80	1,530	7356558
	CHPF4860D6D*+TXV	A*VM971205DNA*	46,000	35,000	17.50	12.80	1,530	7356682
	CHPF4860D6D*+TXV	G*EC961004CNA*	45,500	34,600	17.00	13.00	1,550	7366150
	CA*F4961*6D*+TXV	ADVC81005C*B*	48,000	36,400	17.00	12.20	1,550	6497833
	CA*F4961*6D*+TXV	G*VM960805DXB*	47,000	35,800	17.50	13.00	1,750	5620919
	CA*F4961*6D*+TXV	A*EC961205DNA*	45,500	34,600	17.00	13.00	1,550	7366172
	CA*F4961*6D*+TXV	G*VC961205DNA*	46,000	35,000	17.50	12.80	1,530	7356555
	CHPF4860D6D*+TXV	G*VM970804CNA*	45,500	34,600	17.00	12.80	1,525	7356589
	CHPF4860D6D*+TXV	G*VC951155DXB*	47,500	36,200	18.00	13.00	1,600	5620913
	CHPF4860D6D*+TXV	A*VM971005CNA*	45,500	34,600	17.00	12.80	1,520	7356678
	CA*F4961*6D*+TXV	A*VC950714CXB*	46,000	35,000	17.00	13.00	1,725	5620905
	CHPF4860D6D*+TXV	G*VM971005CNA*	45,500	34,600	17.00	12.80	1,520	7356593
	CHPF4860D6D*+MBVC1600**-1A*+TXV		46,000	35,000	17.00	13.00	1,725	3654393
	CA*F4961*6D*+EEP+TXV		48,000	36,400	15.50	12.50	1,500	5357214
	CHPF4860D6D*+TXV	A*VC951155DXB*	47,500	36,200	18.00	13.00	1,600	6497838
	CSCF4860N6D*+EEP+TXV		48,000	36,400	15.50	12.50	1,500	5357216
	CHPF4860D6D*+TXV	G*EC961205DNA*	45,500	34,600	17.00	13.00	1,550	7366153
	CA*F4961*6D*+TXV	G*VC960804CNA*	45,500	34,600	17.00	12.80	1,525	7356547
	CAPT4961*4A*	G*VM971005CNA*	45,500	34,600	17.00	12.80	1,520	7356592
	CA*F4961*6D*+TXV	G*VC80805C*B*	48,000	36,400	17.00	12.80	1,590	5039230
	CSCF4860N6D*+TXV	A*VM971005CNA*	45,000	34,200	16.50	12.80	1,520	7356679
	CHPF4860D6D*+TXV	A*VC961005CNA*	45,500	34,600	17.00	12.80	1,520	7356638
	CSCF4860N6D*+TXV	G*VC960804CNA*	45,000	34,200	16.50	12.80	1,525	7356550
	CHPF4860D6D*+TXV	G*VM960805CXB*	47,000	35,800	16.50	13.00	1,750	5620918
	CSCF4860N6D*+TXV	A*VC961005CNA*	45,000	34,200	16.50	12.80	1,520	7356639
	CHPF4860D6D*+TXV	A*VM961155DXB*	47,500	36,200	18.00	13.00	1,600	6497842
	CA*F4961*6D*+TXV	A*VC950905CXB*	46,000	35,000	16.50	13.00	1,650	6497827
	CAPT4961*4A*	A*VM970804CNA*	45,500	34,600	17.00	12.80	1,525	7356673
	CHPF4860D6D*+TXV	A*VC961205DNA*	46,000	35,000	17.50	12.80	1,530	7356642
	CHPF4860D6D*+TXV	A*VM960604CXB*	46,000	35,000	17.00	13.00	1,725	5620916
	CA*F4961*6D*+TXV	A*VM960805DXB*	47,000	35,800	17.50	13.00	1,750	6497830
	CHPF4860D6D*+TXV	G*VM961005DXB*	47,500	36,200	18.00	13.00	1,600	5620922
CHPF4860D6D*+TXV	A*VC950905DXB*	47,000	35,800	17.50	13.00	1,750	6497837	
CHPF4860D6D*+TXV	G*VM961155DXB*	47,500	36,200	18.00	13.00	1,600	5620924	
CAPT4961*4A*	G*VM970804CNA*	45,500	34,600	17.00	12.80	1,525	7356588	
CSCF4860N6D*+TXV	G*VM971205DNA*	45,500	34,600	17.00	12.80	1,530	7356598	
CHPF4860D6D*+TXV	A*VM960805DXB*	47,000	35,800	16.50	13.00	1,750	6497840	
CHPF4860D6D*+MBVC2000**-1A*+TXV		47,500	36,200	18.00	13.25	1,750	3654394	
CAPT4961*4A*	G*VM971205DNA*	46,000	35,000	17.50	12.80	1,530	7356596	

See Notes on Page 25.

OUTDOOR UNIT	INDOOR UNITS		COOLING RATINGS				CFM	AHRI #
	COILS/AIR HANDLERS	FURNACES	TOTAL ¹	SENS. ¹	SEER ²	EER ³		
DSXC18 0601A*	CA*F4961*6D*+TXV	A*VC961005CNA*	56,000	40,500	15.50	11.80	1,750	7356644
	CAPT4961*4A*	A*VM971005CNA*	56,000	40,500	15.50	11.80	1,750	7356685
	CHPF4860D6D*+MBVC2000**-1A*+TXV		58,000	42,000	17.00	12.00	2,000	3654439
	CA*F4961*6D*+TXV	G*VC950905DXB*	58,000	42,000	16.00	11.50	1,750	5620927
	CHPF4860D6D*+TXV	A*VM961005DXB*	58,000	42,000	16.00	11.75	1,750	6497857
	CA*F4961*6D*+TXV	G*VM961155DXB*	58,000	42,000	16.00	11.50	1,900	5620939
	CA*F4961*6D*+TXV	G*VC961205DNA*	56,000	40,500	16.00	11.80	1,600	7356563
	CHPF4860D6D*+TXV	G*VC961005CNA*	56,000	40,500	15.50	11.80	1,750	7356561
	CA*F4961*6D*+TXV	G*VC80805C*B*	56,000	40,500	16.00	11.20	1,890	6484852
	CAPT4961*4A*	A*VM971205DNA*	56,000	40,500	16.00	11.80	1,600	7356689
	CA*F4961*6D*+TXV	G*VC951155DXB*	58,000	42,000	16.00	11.50	1,900	5620931
	CSCF4860N6D*+TXV	A*VC961005CNA*	56,000	40,500	15.50	11.80	1,750	7356647
	CA*F4961*6D*+MBVC2000**-1A*+TXV		58,000	42,000	17.00	12.00	2,000	4431669
	CHPF4860D6D*+TXV	G*VM961155DXB*	58,000	42,000	16.00	11.75	1,750	5620940
	CAPT4961*4A*	G*VC961205DNA*	56,000	40,500	16.00	11.80	1,600	7356564
	CA*F4961*6D*+TXV	G*VC961005CNA*	56,000	40,500	15.50	11.80	1,750	7356559
	CHPF4860D6D*+TXV	G*VM971205DNA*	56,000	40,500	16.00	11.80	1,600	7356605
	CHPF4860D6D*+TXV	G*VM971005CNA*	56,000	40,500	15.50	11.80	1,750	7356601
	CHPF4860D6D*+TXV	G*VM960805CXB*	58,000	42,000	16.00	11.50	1,900	5620934
	CA*F4961*6D*+TXV	A*VM960805CXB*	58,000	42,000	16.00	11.50	1,750	6497847
	CHPF4860D6D*+TXV	A*VM961155DXB*	58,000	42,000	16.00	11.75	1,750	6497858
	CHPF4860D6D*+TXV	G*VC950905CXB*	58,000	42,000	16.00	11.50	1,900	5620926
	CAPT4961*4A*	A*VC961005CNA*	56,000	40,500	15.50	11.80	1,750	7356645
	CHPF4860D6D*+TXV	A*VC80805C*B*	56,000	40,500	16.00	11.20	1,890	6484854
	CHPF4860D6D*+TXV	A*VC961005CNA*	56,000	40,500	15.50	11.80	1,750	7356646
	CA*F4961*6D*+EEP+TXV		57,000	41,000	15.00	12.00	1,500	5357217
	CA*F4961*6D*+TXV	G*VM971205DNA*	56,000	40,500	16.00	11.80	1,600	7356603
	CAPT4961*4A*	A*VC961205DNA*	56,000	40,500	16.00	11.80	1,600	7356649
	CA*F4961*6D*+TXV	G*VM960805DXB*	58,000	42,000	16.00	11.50	1,750	5620935
	CHPF4860D6D*+TXV	G*VM961005DXB*	58,000	42,000	16.00	11.75	1,750	5620938
	CA*F4961*6D*+TXV	A*VM961005DXB*	58,000	42,000	16.00	11.50	1,900	6497848
	CA*F4961*6D*+TXV	G*VM971005CNA*	56,000	40,500	15.50	11.80	1,750	7356599
	AVPTC60D14A*		58,000	42,000	16.00	11.75	1,780	5924370
	CHPF4860D6D*+TXV	A*VC950905DXB*	58,000	42,000	16.00	11.50	1,900	6497853
	CA*F4961*6D*+TXV	A*VM961155DXB*	58,000	42,000	16.00	11.50	1,900	6497849
	CHPF4860D6D*+TXV	A*VC951155DXB*	58,000	42,000	16.00	11.75	1,750	6497854
	CAPT4961*4A*	G*VM971005CNA*	56,000	40,500	15.50	11.80	1,750	7356600
	CA*F4961*6D*+TXV	A*VC81005C*B*	56,000	40,500	16.00	11.20	1,800	6484851
	CAPT4961*4A*	G*EC961205DNA*	56,000	40,500	16.00	11.50	1,550	7366155
	CSCF4860N6D*+TXV	G*VM971205DNA*	55,500	40,000	15.50	11.80	1,600	7356606
	CHPF4860D6D*+TXV	A*VM971205DNA*	56,000	40,500	16.00	11.80	1,600	7356690
	CHPF4860D6D*+TXV	G*VC961205DNA*	56,000	40,500	16.00	11.80	1,600	7356565
	CHPF4860D6D*+TXV	G*VC950905DXB*	58,000	42,000	16.00	11.50	1,900	5620928
	CSCF4860N6D*+TXV	G*VC961205DNA*	55,500	40,000	15.50	11.80	1,600	7356566
	CHPF4860D6D*+TXV	G*VC951155DXB*	58,000	42,000	16.00	11.75	1,750	5620932
	CA*F4961*6D*+TXV	A*VC951155DXB*	58,000	42,000	16.00	11.50	1,900	6497846
	CA*F4961*6D*+TXV	A*VC950905CXB*	58,000	42,000	16.00	11.50	1,750	6497844
	CHPF4860D6D*+TXV	A*VM960805DXB*	58,000	42,000	16.00	11.50	1,900	6497856
	CA*F4961*6D*+TXV	A*VC961205DNA*	56,000	40,500	16.00	11.80	1,600	7356648
	CHPF4860D6D*+TXV	A*VC950905CXB*	58,000	42,000	16.00	11.50	1,900	6497852
CA*F4961*6D*+TXV	ADVC81005C*B*	56,000	40,500	16.00	11.20	1,820	6497851	
CSCF4860N6D*+TXV	A*VM971205DNA*	55,500	40,000	15.50	11.80	1,600	7356691	

See Notes on Page 25.

OUTDOOR UNIT	INDOOR UNITS		COOLING RATINGS				CFM	AHRI #
	COILS/AIR HANDLERS	FURNACES	TOTAL ¹	SENS. ¹	SEER ²	EER ³		
DSXC18 0601A* (cont.)	CHPF4860D6D*+TXV	A*VC961205DNA*	56,000	40,500	16.00	11.80	1,600	7356650
	CA*F4961*6D*+TXV	A*VM971005CNA*	56,000	40,500	15.50	11.80	1,750	7356684
	CHPF4860D6D*+TXV	A*EC961205DNA*	56,000	40,500	16.00	11.50	1,550	7366177
	CAPT4961*4A*	A*EC961205DNA*	56,000	40,500	16.00	11.50	1,550	7366176
	CA*F4961*6D*+TXV	A*VM971205DNA*	56,000	40,500	16.00	11.80	1,600	7356688
	CHPF4860D6D*+TXV	G*VC80805C*B*	56,000	40,500	16.00	11.20	1,890	6484856
	CHPF4860D6D*+TXV	A*VM960805CXB*	58,000	42,000	16.00	11.50	1,900	6497855
	CA*F4961*6D*+TXV	G*VC950915DXB*	58,000	42,000	16.00	11.50	1,750	5620930
	CA*F4961*6D*+TXV	A*VC950915DXB*	58,000	42,000	16.00	11.50	1,750	5620929
	CSCF4860N6D*+TXV	G*VM971005CNA*	56,000	40,500	15.50	11.80	1,750	7356602
	CA*F4961*6D*+TXV	A*VC80805C*B*	56,000	40,500	16.00	11.20	1,890	6484850
	CA*F4961*6D*+TXV	G*VC950905CXB*	58,000	42,000	16.00	11.50	1,750	5620925
	CSCF4860N6D*+EEP+TXV		57,000	41,000	15.00	12.00	1,500	5357219
	CA*F4961*6D*+TXV	G*EC961205DNA*	56,000	40,500	16.00	11.50	1,550	7366154
	CAPT4961*4A*	G*VC961005CNA*	56,000	40,500	15.50	11.80	1,750	7356560
	CSCF4860N6D*+TXV	A*VC961205DNA*	55,500	40,000	15.50	11.80	1,600	7356651
	CA*F4961*6D*+TXV	A*EC961205DNA*	56,000	40,500	16.00	11.50	1,550	7366175
	CA*F4961*6D*+TXV	G*VM960805CXB*	58,000	42,000	16.00	11.50	1,750	5620933
	CHPF4860D6D*+TXV	A*VM971005CNA*	56,000	40,500	15.50	11.80	1,750	7356686
	CA*F4961*6D*+TXV	A*VC950905DXB*	58,000	42,000	16.00	11.50	1,750	6497845
	CA*F4961*6D*+TXV	G*VM961005DXB*	58,000	42,000	16.00	11.50	1,900	5620937
	CAPT4961*4A*	G*VM971205DNA*	56,000	40,500	16.00	11.80	1,600	7356604
	CA*F4961*6D*+TXV	ADVC80805C*B*	56,000	40,500	16.00	11.20	1,940	6497850
	CHPF4860D6D*+TXV	A*VC81005C*B*	56,000	40,500	16.00	11.20	1,800	6484855
	CHPF4860D6D*+TXV	G*VM960805DXB*	58,000	42,000	16.00	11.50	1,900	5620936
	CSCF4860N6D*+TXV	A*VM971005CNA*	56,000	40,500	15.50	11.80	1,750	7356687
	CHPF4860D6D*+TXV	G*EC961205DNA*	56,000	40,500	16.00	11.50	1,550	7366156
	CA*F4961*6D*+TXV	G*VC81005C*B*	56,000	40,500	16.00	11.20	1,800	6484853
	CHPF4860D6D*+EEP+TXV		57,000	41,000	15.00	12.00	1,500	5357218
	CHPF4860D6D*+TXV	G*VC81005C*B*	56,000	40,500	16.00	11.20	1,800	6484857
CSCF4860N6D*+TXV	G*VC961005CNA*	56,000	40,500	15.50	11.80	1,750	7356562	

¹ BTU/h

² Seasonal Energy Efficiency Ratio; Certified per AHRI 210/240 @ 80°F/ 67°F/ 95°F

³ Energy Efficiency Ratio @ 80°F/ 67°F/ 95°F

NOTES

- Always check the S&R plate for electrical data on the unit being installed.
- When matching the outdoor unit to the indoor unit, use the piston supplied with the outdoor unit or that specified on the piston kit chart supplied with the indoor unit.
- EEP - Order from Service Dept. Part No. B13707-38 or new Solid State Board B13707-35S. Part No. B13707-38 is not interchangeable with B13707-35S. The Goodman Gas Furnace contains the EEP cooling time delay

DIMENSIONS

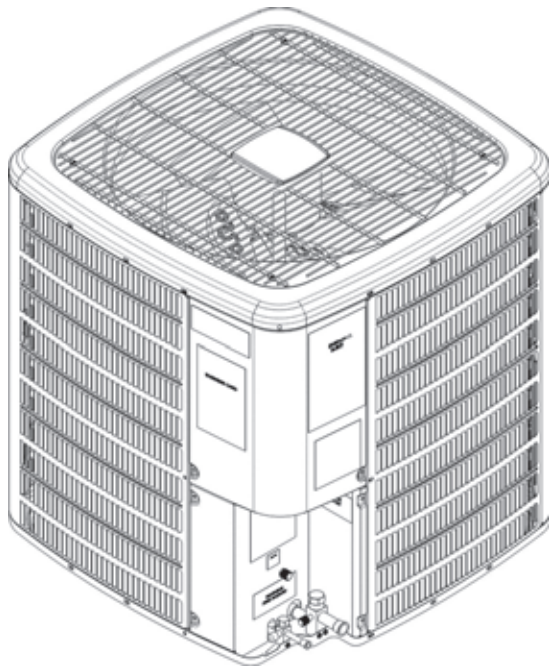

MODEL	W	D	H
DSXC180361A*	35½	35½	38¾
DSXC180481A*	35½	35½	38¾
DSXC180601A*	35½	35½	38¾

WIRING DIAGRAM

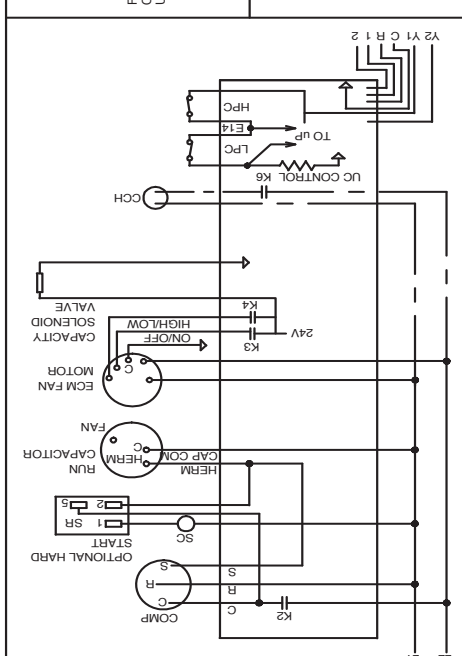
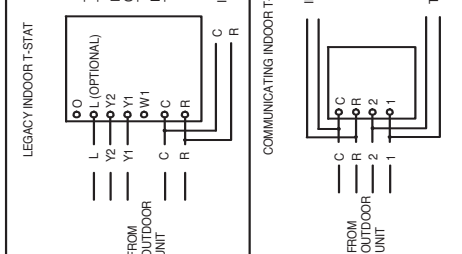
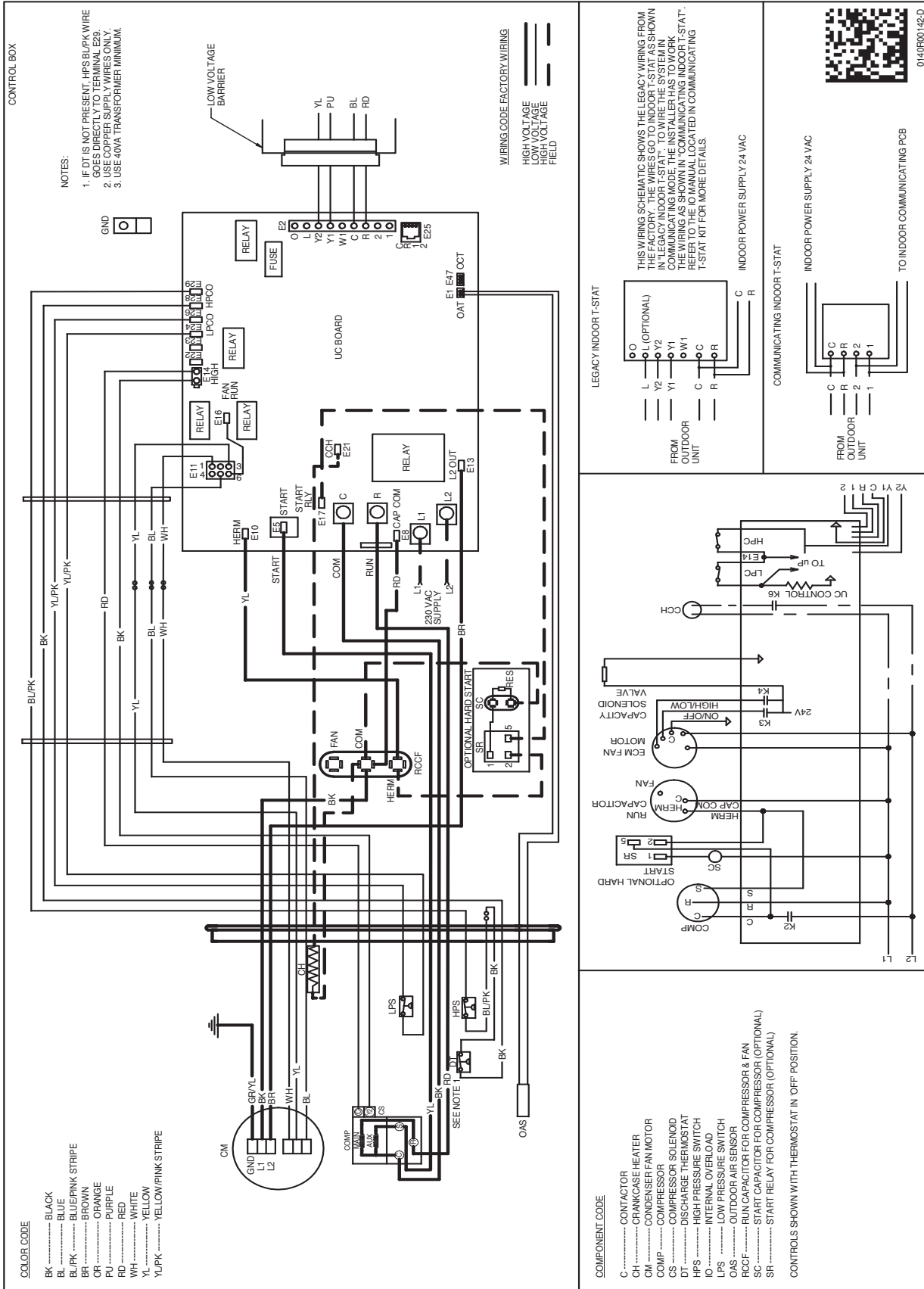

Wiring is subject to change. Always refer to the wiring diagram or the unit for the most up-to-date wiring.

WARNING

High Voltage: Disconnect all power before servicing or installing this unit. Multiple power sources may be present. Failure to do so may cause property damage, personal injury, or death.



0140R00142-D

ACCESSORIES

MODEL	DESCRIPTION	DSXC18 036**	DSXC18 048**	DSXC18 060**
ABK-20	Anchor Bracket Kit ⁰	X	X	X
ASC-01	Anti-Short Cycle Kit	X	X	X
B1141643 ¹	24V Transformer	X	X	X
CSR-U-1	Hard-start Kit	X	X	
CSR-U-2	Hard-start Kit			
CSR-U-3	Hard-start Kit			X
FSK01A ²	Freeze Protection Kit	X	X	X
LSK02A	Liquid Line Solenoid Valve	X	X	X
OT18-60A ³	Outdoor Thermostat/Lockout Thermostat	X	X	X
TX3N4 ⁴	TXV Kit	X		
TX5N4	TXV Kit		X	X

⁰ Contains 20 brackets; four brackets needed to anchor unit to pad

¹ This component is included in the CTK01AA communicating thermostat kit.

² Installed on indoor coil

³ Available in 24V legacy mode only. This feature is integrated in the communicating mode.

⁴ Condensing units and heat pumps with reciprocating compressors require the use of start-assist components when used in conjunction with an indoor coil using a non-bleed thermal expansion valve refrigerant metering device or liquid line solenoid kit. The TXV should always be sized based on the tonnage of the outdoor unit.