



# PCD110XH - Premium Choice with DC Motor

(Ceiling Mounted Ventilation Fans)

## Performance & Dimensions

|                              |                            |     |      |      |
|------------------------------|----------------------------|-----|------|------|
| CFM @ 0.1" SP                | 90                         | 110 | 120  | 140  |
| CFM @ 0.25" SP               | 64                         | 77  | 89   | 100  |
| Sones @ 0.1" SP              | 0.3                        | 0.5 | 0.8  | 1.1  |
| Watts @ 0.1" SP              | 5.5                        | 10  | 11.5 | 14.5 |
| Energy Efficiency (CFM/Watt) | 16.4                       | 11  | 10.4 | 9.7  |
| Amps                         | .16                        | .18 | .22  | .23  |
| Sensor                       | Built-in Humidity Sensor   |     |      |      |
| Duct Connector Diameter (in) | 6"                         |     |      |      |
| Grille Size (in)             | 13" x 14"                  |     |      |      |
| Dimensions (w x d x h) (in)  | 11-3/8" x 10-1/2" x 7-5/8" |     |      |      |

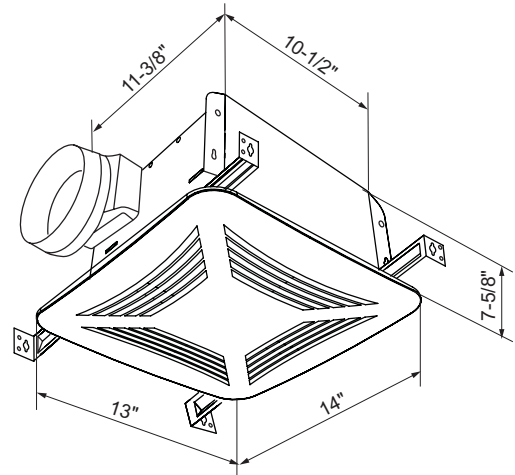

### Features:

- Detects rapid rise in humidity
- Senses humidity at ceiling level
- Adjustable Time Delay shut-off from 3 to 30 minutes
- Field adjustable humidity sensitivity with 50-100% range. Factory setting is 75%

### Optional Accessories:

- Lighted Grille (CFL or LED)
- Metal Grille
- Radiation Damper

### Typical Specifications:

Ventilating fan shall be S&P fan shall be mounted in the ceiling. PCD110XH shall come with a built-in humidity sensor and speed delay timer. The fan shall have a 6-year warranty. The fan shall be HVI Certified at 0.1 inch water gauge for CFM performance above. The motor shall be ETL and cETL Listed with impedance protection plus additional thermal protection.