

INSTALLATION INSTRUCTIONS

COIL ADAPTER KIT

NAHB00101CA, NAHB00201CA, NAHB00301CA

NOTE: Please read these instructions completely before attempting installation.

SAFETY CONSIDERATIONS

Installing and servicing heating equipment can be hazardous due to gas and electrical components. **Only trained and qualified personnel should install, repair, or service heating equipment.** Untrained personnel can perform basic maintenance functions such as cleaning and replacing air filters. All other operations must be performed by trained service personnel. When working on heating equipment, observe precautions in literature, on tags, and on labels attached to or shipped with unit and other safety precautions that may apply.

These instructions cover the minimum requirements and conform to existing national standards and safety codes. In some instances, these instructions exceed certain local codes and ordinances, especially those that may not have kept up with changing residential construction practices. We require these instructions as a minimum for a safe installation.

Wear safety glasses and work gloves. Have a fire extinguisher available during start-up and adjustment procedures and service calls.

Recognize safety information. This is the safety-alert symbol . When you see this symbol on the furnace and in instructions or manuals, be alert to the potential for personal injury.

Understand the signal words DANGER, WARNING, and CAUTION. These words are used with the safety-alert symbol. DANGER identifies the most serious hazards which **will** result in severe personal injury or death. WARNING signifies a hazard which **could** result in personal injury or death. CAUTION is used to identify unsafe practices which **may** result in minor personal injury or product and property damage. NOTE is used to highlight suggestions which **will** result in enhanced installation, reliability, or operation.

INTRODUCTION

This instruction covers the installation of Coil Adapter kit for 35-in tall condensing gas furnaces. The adapters are adjustable to fit all four furnace cabinet widths. The adapters can be used to provide proper fit up of a coil in the upflow or horizontal position, including a coil that is one opening size larger than the furnace supply air opening. The adapters can also be used to make up the difference in height when a 40 inch furnace is replaced by a 35 inch furnace.

The adapters may also be used on 33 1/3-in mid efficiency furnaces. However, due to the shorter length of these furnaces, additional sheet metal transitions or filler pieces may be required.



WARNING

ELECTRICAL SHOCK HAZARD

Failure to follow this warning could result in personal injury or death.

Before installing, modifying, or servicing system, main electrical disconnect switch must be in the OFF position. There may be more than 1 disconnect switch. Lock out and tag switch with a suitable warning label.

DESCRIPTION AND USAGE

There are 3 different kits. Each kit is matched to a specific type of coil offset.

The kit comes in two pieces with screws to attach the assembly together and secure it to the furnace. It is best to assemble the kit on the furnace to optimize fit-up of the adapter to the furnace.

Table 1	Coil Alignment Table	
KIT PART NUMBER	COIL ORIENTATION	COIL ALIGNMENT
NAHB00101CA	No Offset	Coil same width as furnace
NAHB00201CA	Single Offset	Coil flush with one side of furnace
NAHB00301CA	Double Offset	Coil centered on furnace

INSTALLATION

NOTE: For replacement applications, make sure the coil is properly supported to prevent kinking or twisting refrigerant lines.



CAUTION

CUT HAZARD

Failure to follow this caution may result in personal injury.

Sheet metal parts may have sharp edges or burrs. Use care and wear appropriate protective clothing and gloves when handling parts and servicing furnaces.

To install the Coil Adapter kit, perform the following steps.

1. Ensure that the flanges on the supply air outlet of the furnace are turned up 90 degrees.
2. Set each piece of the Coil Adapter on the supply air outlet of the furnace.
3. Slide the adapter half without screw holes in it inside the adapter half with screw holes in it. See **Figure 1**, **Figure 2** and **Figure 3**.
4. Align the Coil Adapter on the supply air outlet of the furnace and secure the front and back halves of the Coil Adapter together with one screw in each hole closest to the furnace supply air outlet.
5. Remove the Coil Adapter and install it on the inlet of the indoor coil.
6. Adjust the Coil Adapter for proper-fit up to the coil and install the remaining screws.
7. Attach the adapter to the furnace as shown in Figure 4. For horizontal installations, refer to the indoor coil orientations and attachment methods shown in Fig 5 and 6. Install the indoor coil in the required orientation for proper airflow through the indoor coil. Refer to the indoor coil installation instructions.
8. If required, seal the Coil Adapter to the furnace and the coil with code approved tape or mastic.

Complete the installation per the requirements in the equipment installation instructions.

Figure 1 **Coil Adapter – Coil Width Same as Furnace**

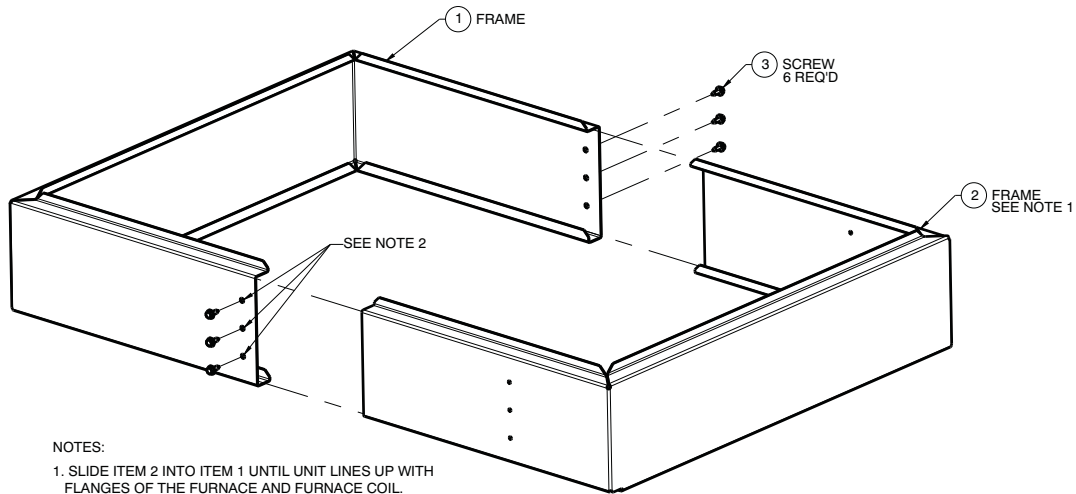

- NOTES:
1. SLIDE ITEM 2 INTO ITEM 1 UNTIL UNIT LINES UP WITH FLANGES OF THE FURNACE AND FURNACE COIL.
 2. INSERT SELF TAPPING SCREWS THRU ITEM 1 INTO ITEM 2.

A11350

Figure 2 **Coil Adapter – Coil One Size Wider than Furnace, Coil Offset to One Side of Furnace**

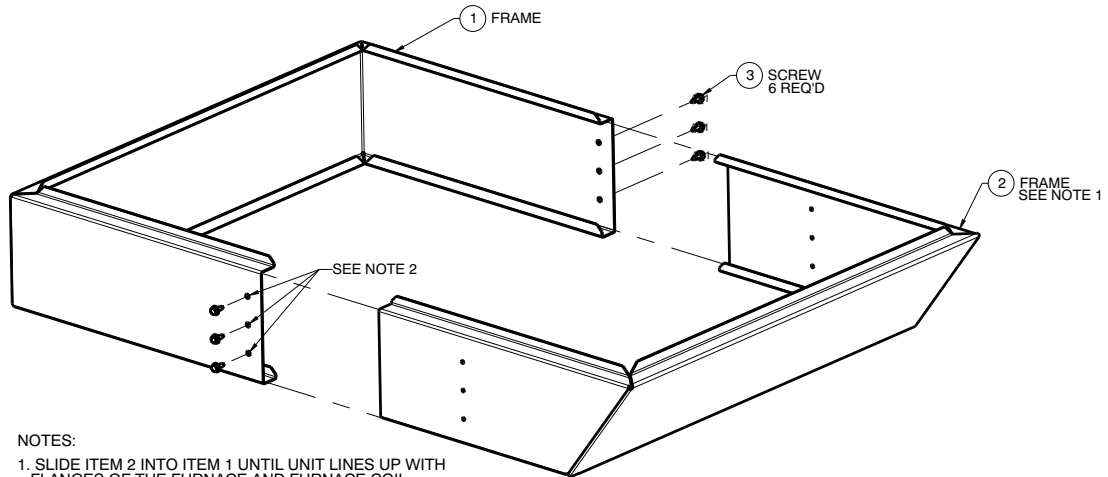

- NOTES:
1. SLIDE ITEM 2 INTO ITEM 1 UNTIL UNIT LINES UP WITH FLANGES OF THE FURNACE AND FURNACE COIL.
 2. INSERT SELF TAPPING SCREWS THRU ITEM 1 INTO ITEM 2.

A11351

Figure 3 **Coil Adapter – Coil One Size Wider than Furnace, Coil Centered on Furnace**

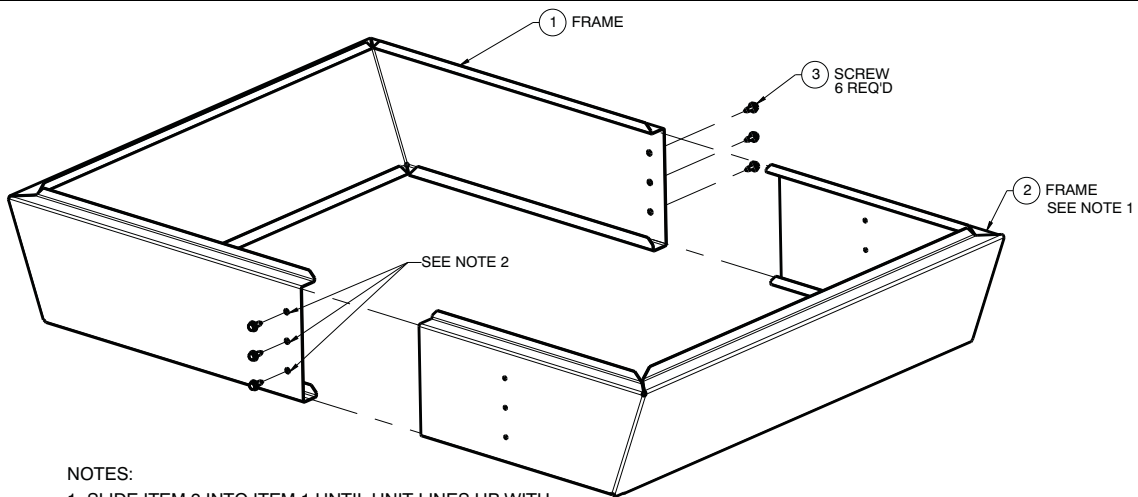

- NOTES:
1. SLIDE ITEM 2 INTO ITEM 1 UNTIL UNIT LINES UP WITH FLANGES OF THE FURNACE AND FURNACE COIL.
 2. INSERT SELF TAPPING SCREWS THRU ITEM 1 INTO ITEM 2.

A11352

Figure 4

Adapter Attachment to Furnace

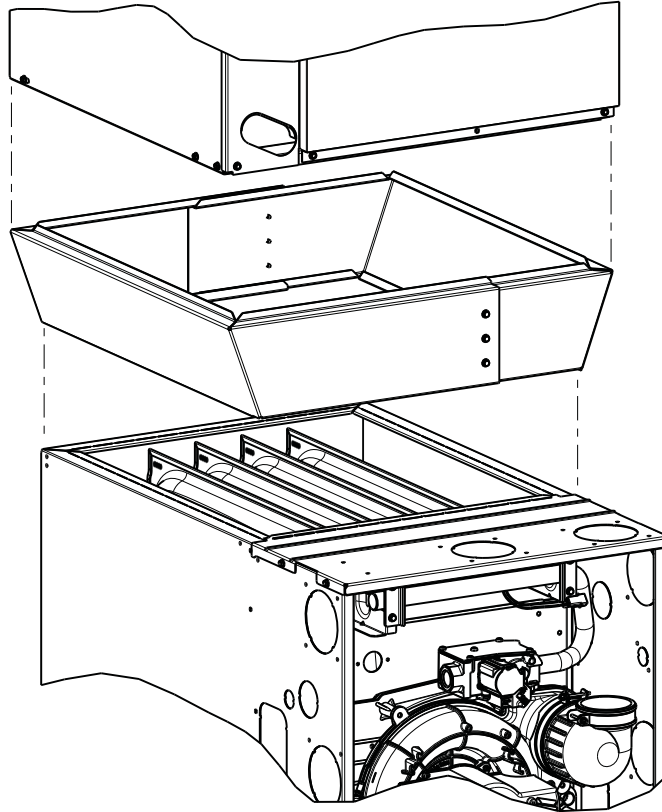

A11355

Figure 5

Horizontal-Right Installation

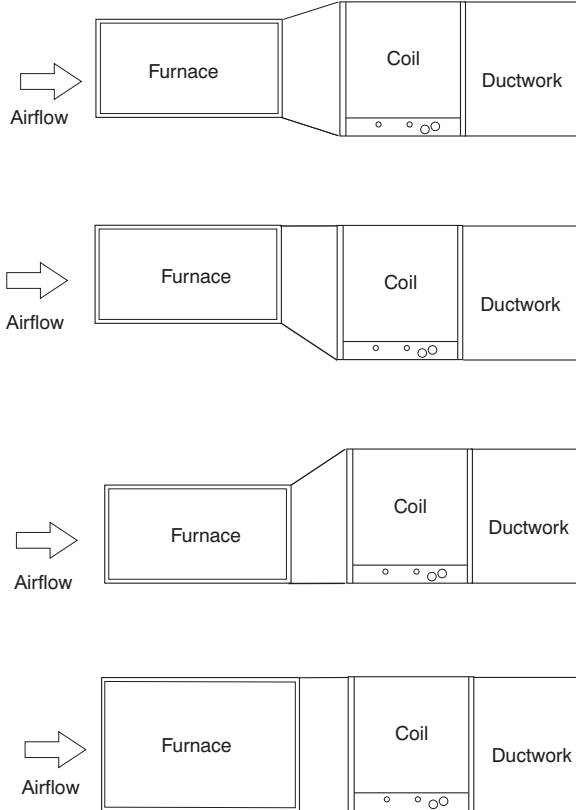

A11353

Figure 6

Horizontal Left Installation

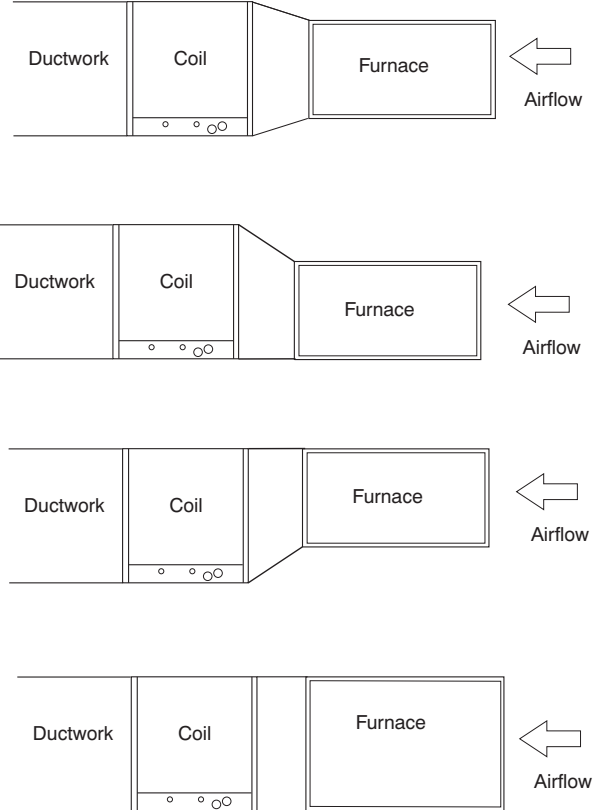

A11354