

INSTALLER: LEAVE THIS MANUAL WITH THE APPLIANCE.  
CONSUMER: RETAIN THIS MANUAL FOR FUTURE REFERENCE.  
NEVER LEAVE CHILDREN OR OTHER AT RISK INDIVIDUALS ALONE WITH THE APPLIANCE.



# INSTALLATION AND OPERATING INSTRUCTIONS

CERTIFIED UNDER AMERICAN NATIONAL STANDARDS, ANSI Z21.11.2b, VOLUME II FOR UNVENTED ROOM HEATERS.

## GVFS60N

NATURAL GAS MODEL

## GVFS60P

PROPANE GAS MODEL

### UNVENTED MILLIVOLT SYSTEM

CERTIFIED FOR THE UNITED STATES USING ANSI METHODS.

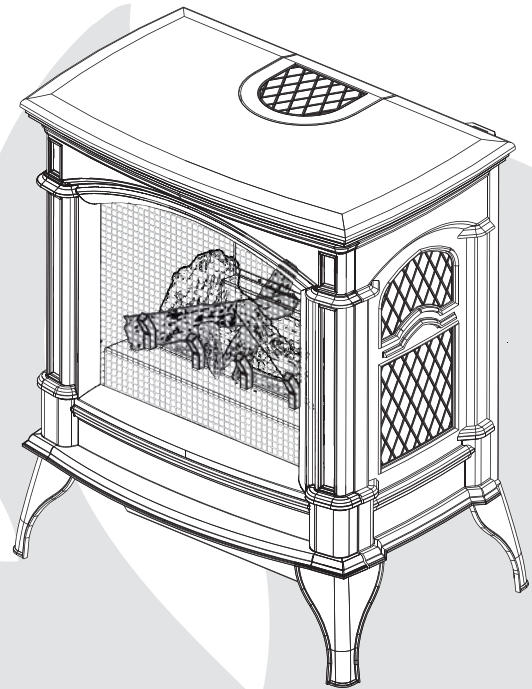

### SAFETY INFORMATION

## ! WARNING

If the information in these instructions are not followed exactly, a fire or explosion may result causing property damage, personal injury or loss of life.

- Do not store or use gasoline or other flammable vapors and liquids in the vicinity of this or any other appliance.
- WHAT TO DO IF YOU SMELL GAS:
  - Do not try to light any appliance.
  - Do not touch any electrical switch; do not use any phone in your building.
  - Immediately call your gas supplier from a neighbour's phone. Follow the gas supplier's instructions.
  - If you cannot reach your gas supplier, call the fire department.
- Installation and service must be performed by a qualified installer, service agency or the supplier.
- This is an unvented gas-fired heater that uses air (oxygen) from the room in which it is installed. Provisions for adequate combustion and ventilation air must be provided. Refer to section "COMBUSTION AND VENTILATION AIR PROVISIONS".

This appliance may be installed in an aftermarket, permanently located, manufactured (mobile) home, where not prohibited by local codes. This appliance is only for use with the type of gas indicated on the rating plate. This appliance is not convertible for use with other gases.

## ! WARNING

HOT GLASS WILL CAUSE BURNS.

DO NOT TOUCH GLASS UNTIL COOLED.

NEVER ALLOW CHILDREN TO TOUCH GLASS.



Wolf Steel Ltd., 24 Napoleon Rd., Barrie, ON, L4M 0G8 Canada /  
103 Miller Drive, Crittenden, Kentucky, USA, 41030

Phone (705)721-1212 • Fax (705)722-6031 • [www.napoleonfireplaces.com](http://www.napoleonfireplaces.com) • [ask@napoleonproducts.com](mailto:ask@napoleonproducts.com)

# TABLE OF CONTENTS

<b>1.0</b>	<b>INSTALLATION OVERVIEW</b>	<b>3</b>
<b>2.0</b>	<b>INTRODUCTION</b>	<b>4</b>
2.1	DIMENSIONS	5
2.2	GENERAL INSTRUCTIONS	5
2.3	GENERAL INFORMATION	6
2.4	RATING PLATE INFORMATION	7
2.5	SHIPPING BRACKET	7
<b>3.0</b>	<b>INSTALLATION</b>	<b>8</b>
3.1	COMBUSTION AND VENTILATION AIR PROVISIONS	8
3.2	DETERMINING CONFINED OR UNCONFINED SPACE	9
3.3	GAS INSTALLATION	10
3.4	OPTIONAL WALL SWITCH	11
3.5	MOBILE HOME	11
<b>4.0</b>	<b>FINISHING</b>	<b>11</b>
4.1	CAST FRONT REMOVAL	11
4.2	LOG PLACEMENT	12
4.3	LOGO PLACEMENT	13
<b>5.0</b>	<b>BLOWER INSTALLATION</b>	<b>13</b>
5.1	SWITCH AND BRACKET INSTALLATION	14
<b>6.0</b>	<b>OPERATION</b>	<b>15</b>
<b>7.0</b>	<b>ADJUSTMENT</b>	<b>16</b>
7.1	VENTURI ADJUSTMENT	16
7.2	FLAME CHARACTERISTICS	16
<b>8.0</b>	<b>MAINTENANCE</b>	<b>17</b>
8.1	OXYGEN DEPLETION SENSOR PILOT CLEANING	17
<b>9.0</b>	<b>REPLACEMENTS</b>	<b>18</b>
<b>10.0</b>	<b>TROUBLESHOOTING</b>	<b>20</b>
<b>11.0</b>	<b>WARRANTY</b>	<b>23</b>
<b>12.0</b>	<b>SERVICE HISTORY</b>	<b>24</b>

**NOTE: Changes, other than editorial, are denoted by a vertical line in the margin**

# 1.0 INSTALLATION OVERVIEW

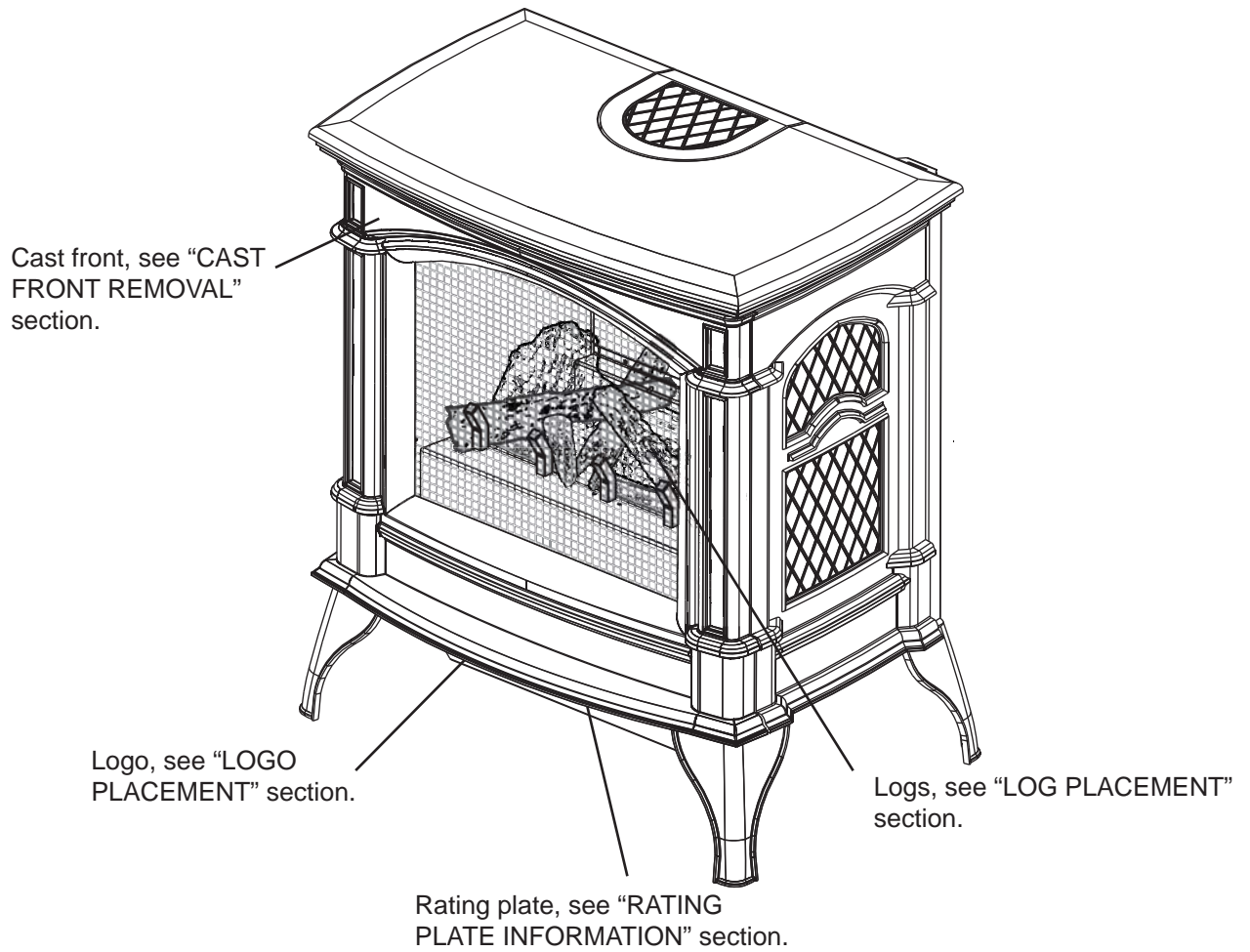

## 2.0 INTRODUCTION

### WARNING

- **THIS APPLIANCE IS HOT WHEN OPERATED AND CAN CAUSE SEVERE BURNS IF CONTACTED.**
- **ANY CHANGES TO THIS APPLIANCE OR ITS CONTROLS CAN BE DANGEROUS AND IS PROHIBITED.**
- Under no circumstances should this appliance be modified.
- Do not operate appliance before reading and understanding operating instructions. Failure to operate appliance according to operating instructions could cause fire or injury.
- Risk of burns. The appliance should be turned off and cooled before servicing.
- Do not install damaged, incomplete or substitute components.
- Risk of cuts and abrasions. Wear protective gloves and safety glasses during installation. Sheet metal edges may be sharp.
- Provide adequate ventilation and combustion air. Provide adequate accessibility clearance for servicing and operating the appliance. Never obstruct the front opening of the appliance.
- If the appliance shuts off, do not re-light until you provide fresh air. If appliance keeps shutting off, have it serviced. Keep burner and control compartment clean.
- Do not burn wood or other materials in this appliance.
- Children and adults should be alerted to the hazards of high surface temperature and should stay away to avoid burns or clothing ignition.
- Young children should be carefully supervised when they are in the same room as the appliance. Toddlers, young children and others may be susceptible to accidental contact burns. A physical barrier is recommended if there are at risk individuals in the house. To restrict access to an appliance, install an adjustable safety gate to keep toddlers, young children and other at risk individuals out of the room and away from hot surfaces.
- Due to high temperatures, the appliance should be located out of traffic and away from furniture and draperies.
- Ensure you have incorporated adequate safety measures to protect infants/toddlers from touching hot surfaces.
- Clothing or other flammable material should not be placed on or near the appliance.
- Check with your local hearth specialty dealer for safety screens and hearth guards to protect children from hot surfaces. These screens and guards must be fastened to the floor.
- Any safety screen or guard removed for servicing must be replaced prior to operating the appliance.
- It is imperative that the control compartments, burners and circulating blower and its passageway in the appliance are kept clean. The appliance should be inspected before use and at least annually by a qualified service person. More frequent cleaning may be required due to excessive lint from carpeting, bedding material, etc. The appliance area must be kept clear and free from combustible materials, gasoline and other flammable vapours and liquids.
- Furniture or other objects must be kept a minimum of 4 feet away from the front of the appliance.
- Do not use this appliance if any part has been under water. Immediately call a qualified service technician to inspect the appliance and to replace any part of the control system and any gas control which has been under water.
- Do not allow fans to blow directly into the appliance. Avoid any drafts that alter burner flame patterns.
- Do not use a blower insert, heat exchanger insert or other accessory not approved for use with this appliance.
- Carbon or soot should not occur in a vent free appliance as it can distribute into the living area of your home. If you notice any signs of carbon or soot, immediately turn off your appliance and arrange to have it serviced by a qualified technician before operating it again.
- Keep the packaging material out of reach of children and dispose of the material in a safe manner. As with all plastic bags, these are not toys and should be kept away from children and infants.
- As with any combustion appliance, we recommend having your appliance regularly inspected and serviced as well as having a Carbon Monoxide Detector installed in the same area to defend you and your family against Carbon Monoxide.
- If equipped, the screen must be in place (closed) when the appliance is in operation.
- Ensure clearances to combustibles are maintained when building a mantel or shelves above the appliance. Elevated temperatures on the wall or in the air above the appliance can cause melting, discolouration or damage to decorations, a T.V. or other electronic components.

3.4B

## 2.1 DIMENSIONS

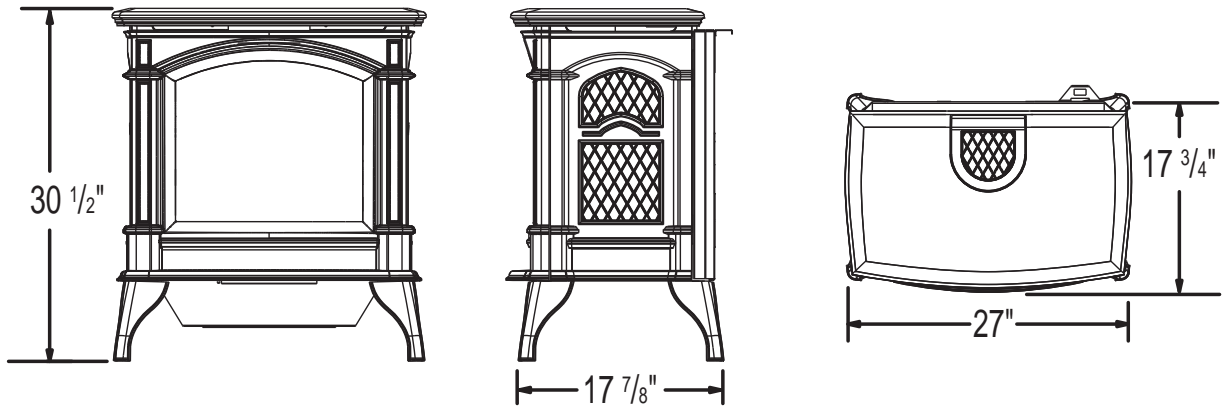

## 2.2 GENERAL INSTRUCTIONS

<b>! WARNING</b>
<p><b>* CARBON MONOXIDE POISONING MAY LEAD TO DEATH</b>  <b>EARLY SIGNS OF CARBON MONOXIDE POISONING RESEMBLE THE FLU, WITH HEADACHE, DIZZINESS AND/OR NAUSEA. IF YOU HAVE THESE SIGNS, THE HEATER MAY NOT BE WORKING PROPERLY. GET FRESH AIR AT ONCE! HAVE HEATER SERVICED.</b>  <b>SOME PEOPLE---PREGNANT WOMEN, PERSONS WITH HEART OR LUNG DISEASE, ANEMIA, THOSE UNDER THE INFLUENCE OF ALCOHOL, THOSE AT HIGH ALTITUDES--- ARE MORE AFFECTED BY CARBON MONOXIDE THAN OTHERS.</b></p>
<p><b>THE APPLIANCE IS ONLY FOR USE WITH THE TYPE OF GAS INDICATED ON THE RATING PLATE. THIS APPLIANCE IS NOT CONVERTIBLE FOR USE WITH OTHER GASES.</b></p>
<p><b>OBJECTS PLACED IN FRONT OF THE HEATER SHOULD BE KEPT A MINIMUM OF 48" AWAY FROM THE FRONT FACE OF THE APPLIANCE.</b></p>
<p><b>USE ONLY WOLF STEEL APPROVED OPTIONAL ACCESSORIES AND REPLACEMENT PARTS WITH THIS APPLIANCE. USING NON-LISTED ACCESSORIES AND REPLACEMENT PARTS (BLOWERS, LOUVRES, TRIMS, GAS COMPONENTS, VENT COMPONENTS, ETC.) COULD RESULT IN A SAFETY HAZARD AND WILL VOID THE LIMITED LIFETIME WARRANTY.</b></p>
<p><b>NOT DESIGNED FOR USE WITH A GLASS DOOR. SCREEN MUST BE CLOSED WHEN APPLIANCE IS IN OPERATION.</b></p>
<p><b>THIS APPLIANCE MUST NOT BE INSTALLED IN A BEDROOM OR BATHROOM.</b></p>

This gas appliance should be installed and serviced by a qualified installer to conform with local codes. Installation practices vary from region to region and it is important to know the specifics that apply to your area, for example: in Massachusetts State:

- The appliance off valve must be a "T" handle gas cock.
- The flexible connector must not be longer than 36".
- The appliance is not approved for installation in a bedroom or bathroom unless the appliance is a direct vent sealed combustion product.
- A carbon monoxide detector is required in all rooms containing gas fired appliances.
- **WARNING:** This product must be installed by a licensed plumber or gas fitter when installed within the commonwealth of Massachusetts.
- Un-vented room appliance shall be installed in accordance with 527 CMR 30.00 and 248 CMR 3.00 through 7.00.
- Sellers of un-vented propane or natural gas-fired space / room appliances shall provide to each purchaser a copy of 527 CMR 30.00 upon the sale of the appliance from [http://www.napoleonfireplaces.com/Webshare/installation\\_manuals/mass\\_requirements.pdf](http://www.napoleonfireplaces.com/Webshare/installation_manuals/mass_requirements.pdf)

In absence of local codes, install the appliance to the current National Fuel Gas Code, ANSI Z223.1 Installation Code which can be obtained from:

**American National Standards Institute Inc.**  
1430 Broadway  
New York, NY 10018

or **National Fire Protection Association Inc.**  
Batterymarch Park  
Quincy, MA 02269

The appliance and its individual shutoff valve must be disconnected from the gas supply piping system during any pressure testing of that system at test pressures in excess of 1/2 psig (3.5 kPa). The appliance must be isolated from the gas supply piping system by closing its individual manual shutoff valve during any pressure testing of the gas supply piping system at test pressures equal to or less than 1/2 psig (3.5 kPa). When installed with a blower the junction box must be electrically connected and grounded in accordance with local codes. In the absence of local codes, use the current ANSI / NFPA 70 National Electric Code. In the case where the blower is equipped with a power cord it must be connected into a properly grounded receptacle. The grounding prong must not be removed from the cord plug.

As long as the required clearance to combustibles is maintained, the most desirable and beneficial location for the appliance is in the center of a building, thereby allowing the most efficient use of the heat created. The location of windows, doors and the traffic flow in the room where the appliance is to be located should be considered.



If the appliance is installed directly on carpeting, vinyl tile or other combustible material other than wood flooring, the appliance shall be installed on a metal or wood panel extending the full width and depth. **NOTE: This does not apply to stoves.**

\* Air shortage caused by an inadequate air supply, improper log positions, the addition of foreign or unapproved materials or the failure to properly maintain the appliance, may result in incomplete combustion of the fuel. Incomplete combustion results in soot being deposited inside the firebox as well as surfaces outside the appliance. If any soot deposits are observed, shut off the appliance immediately and arrange for it to be serviced by a qualified technician.

4.2C

## 2.3 GENERAL INFORMATION

**FOR YOUR SATISFACTION, THIS APPLIANCE HAS BEEN TEST-FIRED TO ASSURE ITS OPERATION AND QUALITY!**

<b>GVFS60</b>		
	<b>NG</b>	<b>LP</b>
Altitude (FT)	0 - 2,000	0 - 2,000
Max. Input (BTU/HR)	30,000	30,000
Min. Inlet Gas Supply Pressure	4.5" Water Column	11" Water Column
Max. Inlet Gas Supply Pressure	7" Water Column	13" Water Column
Manifold Pressure (Under Flow Conditions)	3.5" Water Column	10" Water Column

No external electricity (110 volts or 24 volts) is required for the gas system operation. Expansion / contraction noises during heating up and cooling down cycles are normal and are to be expected.

The appliance is equipped with a pilot light safety system referred to as an oxygen depletion sensor and is designed to turn off the appliance if not enough fresh air is available.

When the appliance is installed at elevations above 2,000 ft and in the absence of specific recommendations from the local authority having jurisdiction, the certified high altitude input rating shall be reduced at the rate of 4% for each additional 1,000 ft.

## 2.4 RATING PLATE INFORMATION

CERTIFIED UNDER: ANSI Z21.11.2b-2008 VOLUME II, UNVENTED ROOM HEATER

THIS IS A GAS-FIRED UNVENTED ROOM HEATER THAT REQUIRES ADEQUATE COMBUSTION AND VENTILATION AIR. THIS APPLIANCE IS NOT FIELD CONVERTIBLE FOR USE WITH OTHER FUELS.

THIS UNIT IS NOT APPROVED FOR BEDROOM, BATHROOM AND BED-SITTING ROOM INSTALLATION.

DIAGRAM TO AID IN THE OPERATION OF THIS FIREPLACE:

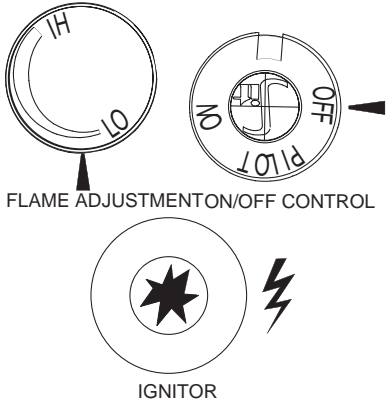

9700539 (WSL) ■ Intertek ■ 4001657 (NGZ)  
4001658 (NAC) ■ 4001659 (WUSA)

GVFS60-N ■ CVFS600-N ■ MODEL ■ GVFS60-P ■ CVFS600-P

\*\* 0-2000FT (0-610M) ALTITUDE INPUT \*\* 0-2000FT (0-610M)

30,000 BTU/h 30,000 BTU/h  
20,000 BTU/h 20,000 BTU/h

REDUCED INPUT

MANIFOLD PRESSURE: 3.5" WATER COLUMN  
MINIMUM SUPPLY PRESSURE: 4.5" WATER COLUMN  
MAXIMUM SUPPLY PRESSURE: 7.0" WATER COLUMN  
SIT CONTROL: #820637  
OPERATING PILOT OXYPROTECTOR: # 8214

MANIFOLD PRESSURE: 10" WATER COLUMN  
MINIMUM SUPPLY PRESSURE: 11" WATER COLUMN  
MAXIMUM SUPPLY PRESSURE: 13" WATER COLUMN  
SIT CONTROL: #820636  
OPERATING PILOT OXYPROTECTOR: #8404

\*\*ABOVE 2,000FT, CONSULT LOCAL AUTHORITY HAVING JURISDICTION

**NOT FOR USE WITH SOLID FUEL.**

MINIMUM CLEARANCE TO COMBUSTIBLE MATERIALS

A	6"	B/W (W/A)	B/W (W/A)
B	6"	45°	45°
C	2"	170° W/S	170° W/S

46" TO CEILING FROM STOVE TOP

WARNING: DO NOT ADD ANY MATERIAL TO THE APPLIANCE, WHICH WILL COME IN CONTACT WITH THE FLAMES, OTHER THAN THAT SUPPLIED BY THE MANUFACTURER WITH THE APPLIANCE!  
SCREEN MUST BE IN PLACE WHILE THE FIREPLACE IS IN OPERATION.  
ELECTRICAL RATING: 115V 0.82AMP, 60HZ  
OPTIONAL FAN KIT: GS-64KT

WOLF STEEL LTD.  
24 NAPOLEON ROAD, BARRIE, ONTARIO L4M 0G8 CANADA

SERIAL NUMBER GVFS60

W385-0184 / F

This illustration is for reference only. Refer to the rating plate on the appliance for accurate information.

For rating plate location, see "INSTALLATION OVERVIEW" section.

## 2.5 SHIPPING BRACKET

**! WARNING**

THE TOP CASTING IS NOT FASTENED TO THE APPLIANCE ASSEMBLY. IT SIMPLY SITS ON THE APPLIANCE AS A LID. FOR SHIPPING PURPOSES IT IS HELD IN PLACE BY PLASTIC STRAPPING. ONCE THE STRAPPING IS CUT, THE TOP SHOULD BE LIFTED OFF CAREFULLY AND STORED IN A SAFE PLACE TO AVOID DAMAGE WHILE COMPLETING THE INSTALLATION OF THE APPLIANCE. TO AVOID THE APPLIANCE BEING DAMAGED DURING SHIPPING, A SHIPPING BRACKET HAS BEEN USED AND MUST BE UNBOLTED BEFORE THE APPLIANCE CAN BE INSTALLED.

### SHIPPING BRACKET REMOVAL

- Remove the four screws holding the shipping bracket to the bottom of the appliance.
- Lift the appliance off the skid and set on a flat surface.
- Discard the screws, brackets and skid.

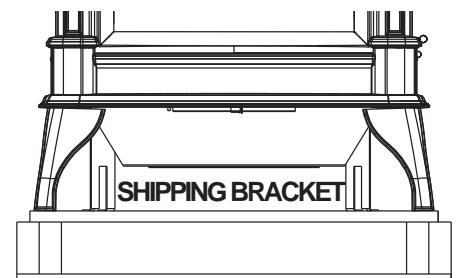

## 3.0 INSTALLATION

Provide adequate ventilation and combustion air, see “COMBUSTION AND VENTILATION AIR PROVISIONS” section. Provide adequate accessibility clearance for servicing and operating the appliance.

**Never obstruct the front opening of the appliance.**

As long as clearance to combustibles is kept within the required distances, the most desirable and beneficial location for an appliance is in the centre of a building, thereby allowing the most efficient use of the heat created. The location of windows, doors and the traffic flow in the room where the appliance is to be located should be considered.

**Maintain these minimum clearances to combustibles:**

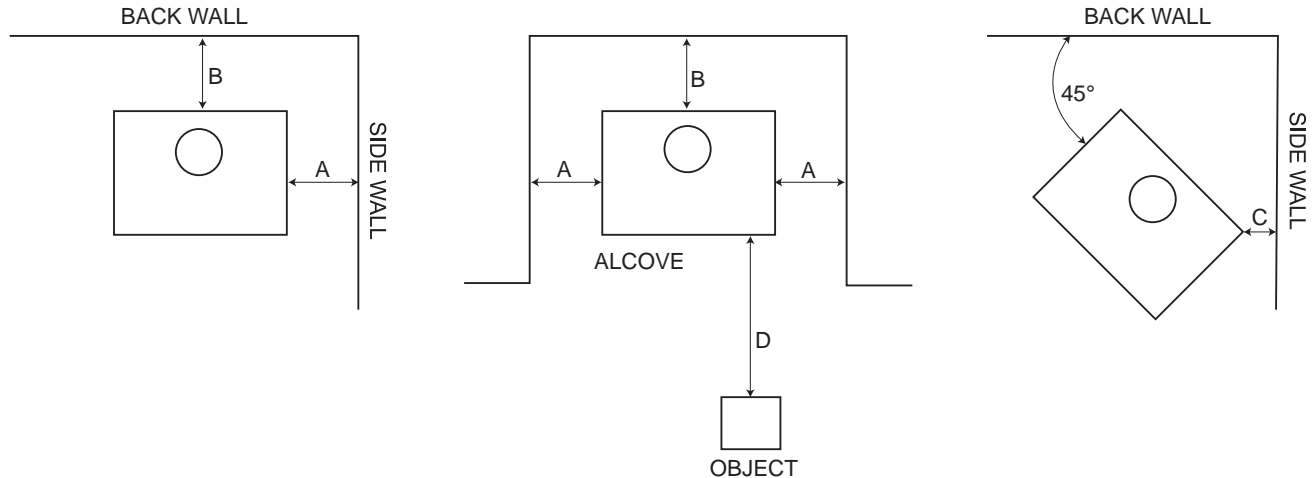

**A. 6" B. 6" C. 2"\* D. 4'**

No additional floor protection is required.

Minimum 46" from appliance top to ceiling.

\* At a distance of 2" from the wall, access to the blower switch, on-off switch or the blower power cord may not be practical.

### 3.1 COMBUSTION AND VENTILATION AIR PROVISIONS

This appliance shall not be installed in a confined space or unusually tight construction unless provisions are provided for adequate combustion and ventilation air.

The National Fuel Gas Code, ANSI Z223.1 / NFPA 54 defines a confined space as a space whose volume is less than 50 cubic feet per 1,000 Btu per hour (4.8 m<sup>3</sup> per kw) of the aggregate input rating of all appliances installed in that space and an unconfined space as a space whose volume is not less than 50 cubic feet per 1,000 Btu per hour (4.8 m<sup>3</sup> per kw) of the aggregate input rating of all appliances installed in that space. Rooms communicating directly with the space in which the appliances are installed, through openings not furnished with doors are considered a part of the unconfined space.

17.1A

The GVFS60 is rated at 30,000 BTUs per hour and therefore requires a minimum unconfined space of 1,500 cubic feet.



### 3.2 DETERMINING CONFINED OR UNCONFINED SPACE

To determine the volume of the room where the appliance is to be installed, multiply the width x the length x the ceiling height of that room measured in feet. If any adjoining rooms are connected by grilles or openings such as kitchen pass-throughs, etc., the volume of those rooms may be added to the total.

Multiply the room volume by 1000 and divide this amount by 50 to determine the maximum BTU/hr that the space can support with adequate combustion and ventilation air.

Add the Btu/hr of all fuel burning appliances located within the space such as gas furnace, gas water appliance, etc. Do not include direct vent gas appliances which draw their input and output air from and to the outdoors.

#### **! WARNING**

**IF THE AREA IN WHICH THE APPLIANCE MAY BE OPERATED IS SMALLER THAN THAT DEFINED AS AN UNCONFINED SPACE OR IF THE BUILDING IS OF UNUSUALLY TIGHT CONSTRUCTION, PROVIDE ADEQUATE COMBUSTION AND VENTILATION AIR BY ONE OF THE METHODS DESCRIBED IN THE NATIONAL FUEL GAS CODE ANSI Z223.1/ NFPA 54 , AIR FOR COMBUSTION AND VENTILATION, OR THE APPLICABLE LOCAL CODE.**

**IF THE AREA IN WHICH THE APPLIANCE MAY BE OPERATED DOES NOT MEET THE REQUIRED VOLUME FOR INDOOR COMBUSTION AIR, COMBUSTION AND VENTILATION AIR SHALL BE PROVIDED BY ONE OF THE METHODS DESCRIBED IN THE ANSI Z223.1 / NFPA 54, THE INTERNATIONAL FUEL GAS CODE, OR APPLICABLE LOCAL CODES.**

Unusually tight construction is defined as construction where:

- A) Walls and ceilings exposed to the outside atmosphere have a continuous water vapour retarder with a rating of 1 perm (6 x 10<sup>-11</sup> kg per pa-sec-m<sup>2</sup>) or less with openings gasketed or sealed, and
- B) Weather stripping has been added on openable windows and doors, and
- C) Caulking or sealants are applied to areas such as joints around window and door frames, between sole plates and floors, between wall-ceiling joints, between wall panels, at penetrations for plumbing, electrical, and gas lines, and at other openings.

An unvented room appliance is recommended for use as a secondary heat source rather than as a primary source. Gas combustion produces water vapour which could occur at the rate of approximately one ounce of water for every 1,000 BTU/hr of gas input. During the cold weather season, indoor humidity levels tend to be low. Consequently, this water vapour can enhance the living space. However if a problem should occur:

- A) Ensure sufficient combustion and circulation air
- B) Use a dehumidifier
- C) Do not use the unvented room appliance as a primary heat source

Without sufficient fresh air for proper operation, poor fuel combustion can result. Carbon Monoxide is a result of poor combustion.

If additional fresh air is required, use one of the methods described in the National Fuel Gas Code, ANSI Z223.1 / NFPA54 or the applicable local code.

Room Volume = Length x Width x Height

Max BTU/hr = Room Volume x 1000 / 50

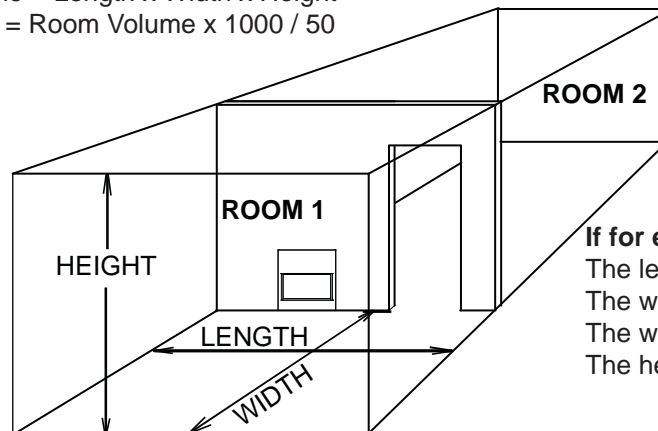

**If for example:**

The length of the rooms is 10 feet,  
The width of Room 1 is 10 feet,  
The width of Room 2 is 15 feet,  
The height of the rooms is 8 feet.

The volume of Room 1: 10x10x8 = 800 cubic feet  
The volume of Room 2: 10x15x8 = 1200 cubic feet

**EXAMPLE 1:**

In this example, because there is no door to the adjoining room, the volume of the adjoining room may be added to the volume of the room with the heater to get a total unconfined space.

The total unconfined space:  $800 + 1200 = 2000$  cubic feet.

Maximum BTU/h:  $\frac{2000 \times 1000}{50} = 40,000$  BTU/h

19.2

If there are no more fuel burning appliances within this space then the 30,000 BTU/h input of the appliance is suitable to be installed. This also assumes that the construction of this space is not unusually tight.

**EXAMPLE 2:**

If in this example a solid door separates Room 1 from Room 2, the volume of Room 2 could not be used. In this case the maximum BTU/h would be:

Maximum BTU/h:  $\frac{800 \times 1000}{50} = 16,000$  BTU/h

19.3

This would be considered a confined space since it can not support the 30,000 BTU/h input of the appliance and it would be necessary to provide adequate combustion and ventilation air to Room 1.

## 3.3 GAS INSTALLATION

 <b>WARNING</b>
<b>RISK OF FIRE, EXPLOSION OR ASPHYXIATION. ENSURE THERE ARE NO IGNITION SOURCES SUCH AS SPARKS OR OPEN FLAMES.</b>
<b>SUPPORT GAS CONTROL WHEN ATTACHING GAS SUPPLY PIPE TO PREVENT DAMAGING GAS LINE.</b>
<b>ALWAYS LIGHT THE PILOT WHETHER FOR THE FIRST TIME OR IF THE GAS SUPPLY HAS RUN OUT WITH THE GLASS DOOR OPENED OR REMOVED. PURGING OF THE GAS SUPPLY LINE SHOULD BE PERFORMED BY A QUALIFIED SERVICE TECHNICIAN. ASSURE THAT A CONTINUOUS GAS FLOW IS AT THE BURNER BEFORE CLOSING THE DOOR. ENSURE ADEQUATE VENTILATION. FOR GAS AND ELECTRICAL LOCATIONS, SEE "DIMENSION" SECTION.</b>
<b>ALL GAS CONNECTIONS MUST BE CONTAINED WITHIN THE APPLIANCE WHEN COMPLETE.</b>
<b>HIGH PRESSURE WILL DAMAGE VALVE. DISCONNECT GAS SUPPLY PIPING BEFORE TESTING GAS LINE AT TEST PRESSURES ABOVE 1/2 PSIG.</b>
<b>VALVE SETTINGS HAVE BEEN FACTORY SET, DO NOT CHANGE.</b>

Installation and servicing to be done by a qualified installer.

- A. Move the appliance into position and secure.
- B. If equipped with a flex connector the appliance is designed to accept a 1/2" gas supply. Without the connector it is designed to accept a 3/8" gas supply. The appliance is equipped with a manual shut off valve to turn off the gas supply to the appliance.
- C. Connect the gas supply in accordance to local codes. In the absence of local codes, install to the current CAN/CSA-B149.1 Installation Code in Canada or to the current National Fuel Gas Code, ANSI Z223.1 / NFPA 54 in the United States.
- D. When flexing any gas line, support the gas valve so that the lines are not bent or kinked.
- E. The gas line flex-connector should be installed to provide sufficient movement for shifting the burner assembly on it's side to aid with servicing components.
- F. Check for gas leaks by brushing on a soap and water solution. **Do not use open flame.**

30.1A

3.4 OPTIONAL WALL SWITCH

**! WARNING**

**DO NOT CONNECT EITHER THE WALL SWITCH, THERMOSTAT OR GAS VALVE DIRECTLY TO 110 VOLT ELECTRICITY.**

For ease of accessibility, an optional remote wall switch or millivolt thermostat may be installed in a convenient location. Route a 2 strand, solid core millivolt wire from the valve to the wall switch or millivolt thermostat. The recommended maximum lead length depends on wire size:

WIRE SIZE	MAX. LENGTH
14 gauge	100 feet
16 gauge	60 feet
18 gauge	40 feet

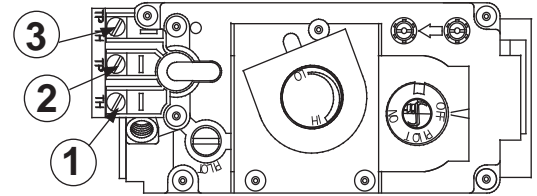

Disconnect the existing wires from terminals 1 and 3 (from the ON/OFF switch) and replace with the leads from the wall switch / millivolt thermostat.

50.1

3.5 MOBILE HOME

Suitable for mobile home installation where the mobile home has been permanently placed on its site. This appliance may be installed in an aftermarket permanently located, manufactured (mobile) home, where not prohibited by local codes. For mobile home installations, the appliance must be fastened in place. It is recommended that the appliance be secured in all installations. See "REPLACEMENTS" section for the levelling / securing kit specific to your appliance.

29.2

4.0 FINISHING

**! WARNING**

**RISK OF FIRE!**

**NEVER OBSTRUCT THE FRONT OPENING OF THE APPLIANCE.**

**DO NOT STRIKE, SLAM OR SCRATCH GLASS. DO NOT OPERATE APPLIANCE WITH GLASS REMOVED, CRACKED, BROKEN OR SCRATCHED.**

72.4

4.1 CAST FRONT REMOVAL

**! WARNING**

**FRONT / SCREEN MUST BE IN PLACE WHILE THE APPLIANCE IS IN OPERATION.**

- A. Lift the top casting off the unit.
- B. Loosen the securing bolts on the cast front off of each of the respective retainer brackets (located at either side on the top). Lift the front casting off and place the cast front face down on a protective surface such as a carpet or blanket to avoid scratching the finished surface.
- C. To re-install the front, repeat in reverse order and ensure bottom locating tabs engage on either leg.

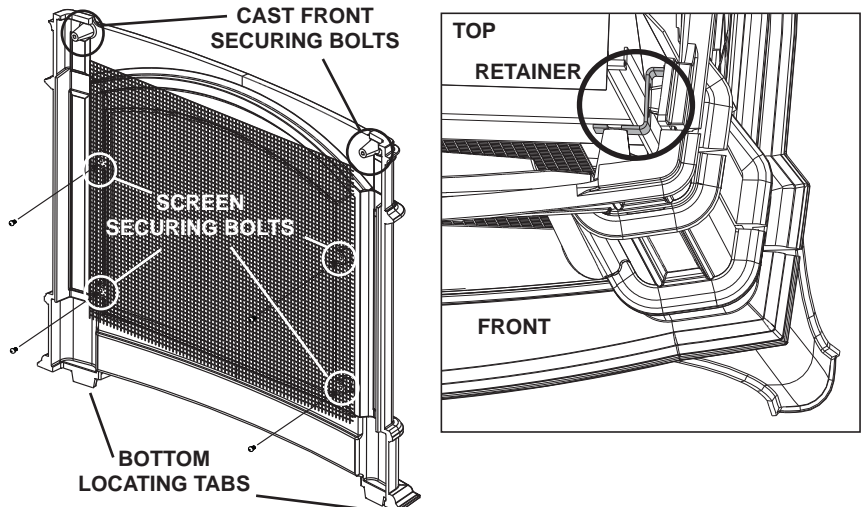

## ! WARNING

**FAILURE TO POSITION THE LOGS IN ACCORDANCE WITH THESE DIAGRAMS OR FAILURE TO USE ONLY LOGS SPECIFICALLY APPROVED WITH THIS APPLIANCE MAY RESULT IN PROPERTY DAMAGE OR PERSONAL INJURY.**

**LOGS MUST BE PLACED IN THEIR EXACT LOCATION IN THE APPLIANCE. DO NOT MODIFY THE PROPER LOG POSITIONS, SINCE APPLIANCE MAY NOT FUNCTION PROPERLY AND DELAYED IGNITION MAY OCCUR.**

**THE LOGS ARE FRAGILE AND SHOULD BE HANDLED WITH CARE.**

76.1A

Blocked burner ports can cause an incorrect flame pattern, carbon deposits and delayed ignition. **PHAZER™** logs glow when exposed to direct flame and provide a unique and realistic glowing effect. Use only certified **PHAZER™** logs available from your local authorized dealer / distributor.

- A. Place log #1 onto the burner, centering it onto the burner tray and pushing it as close to the rear wall of the firebox as possible. Move logs #2 and #3 into position, lining up the studs located on the burner with the holes on the bottom of the logs. Sit the notch at the bottom of log #4 against the left outermost grate post and position the top of the log into the pocket provided on the rear log (#1).
- B. The notch in log #5 should be pressed down onto the skewering pin located at the end of the grate as shown to prevent it from rocking.
- C. Position the notch located in log #6 against the grate post and rest it within the notch in log #4.
- D. Place the bottom of log #7 against the right outermost grate post and the top into the pocket provided on the center log (#6). Bend up the tab in the log support to cradle log #7. Tear the glowing embers into pieces and place onto the front of the burner. Care should be taken to shred the embers into thin, small irregular pieces as only the exposed edges of the fibre hairs will glow when exposed to direct flame; however care should be taken to not block the burner ports. Blocked ports can cause an incorrect flame pattern, carbon deposits and delayed ignition.

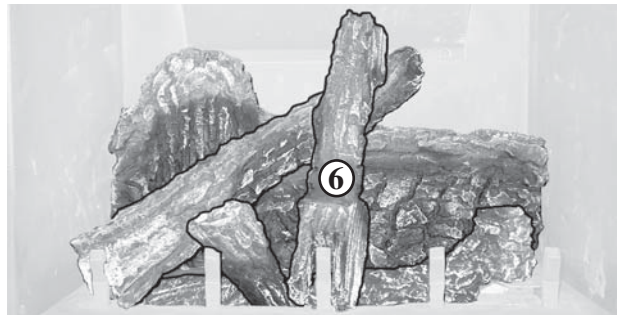
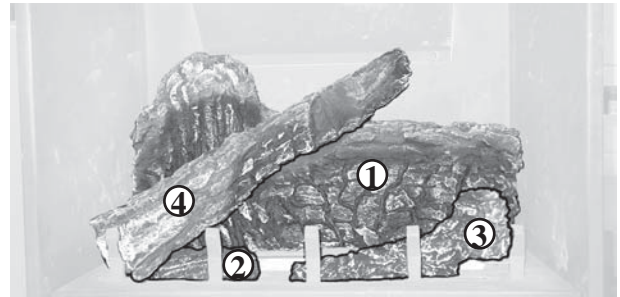

Replacement loose material must be purchased from the original room appliance manufacturer. Application of excess loose material may adversely affect the performance of the appliance.

Log colours may vary. During the initial use of the appliance, the colours will become more uniform as colour pigments burn in during the heat activated curing process.

**POSITIONING THE LOGS IMPROPERLY WILL CAUSE FLAME IMPINGEMENT AND CARBONING.**

### 4.3 LOGO PLACEMENT

Remove the backing of the logo supplied and centre over the logo installation holes, as indicated.

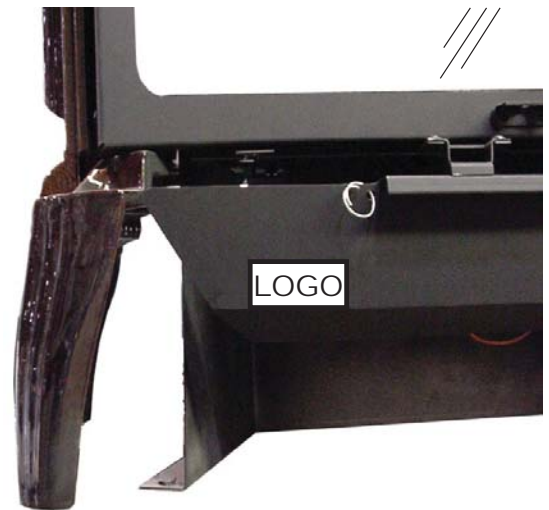

## 5.0 BLOWER INSTALLATION

- A. Ensure that the access cover plate has been installed.
- B. Remove the on/off switch bracket and the cover plate below it. The cover plate may now be discarded.
- C. Decide which side of the blower housing you prefer the on/off switch to be located on.
- D. Remove the 2 screws from the top outer edge of the rear appliance panel. The housing is mounted using these two holes, as well as two other holes located in the rear panel.
- E. Mount and secure the blower housing using 4 screws. Ensure that the on/off switch wires pass through the appropriate slot located on either side of the blower housing.
- F. Remove the 2 screws from the side of the blower housing that you want the switch to be located on and re-secure the on/off switch.

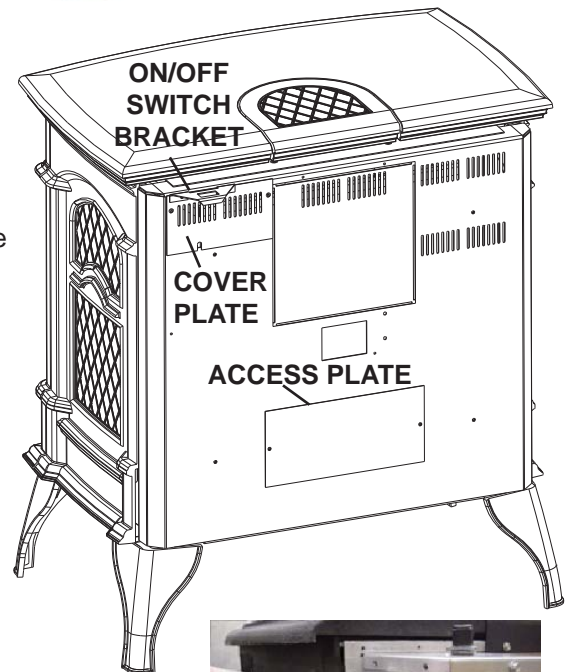

Because the blower is thermally activated, when turned on, it will automatically start approximately 15-30 minutes after lighting the appliance and will run for approximately 30-45 minutes after the appliance has been turned off. Use of the fan increases the output of heat.

Drywall dust will penetrate into the blower bearings, causing irreparable damage. Care must be taken to prevent drywall dust from coming into contact with the blower or its compartment. Any damage resulting from this condition is not covered by the warranty policy.



5.1 SWITCH AND BRACKET INSTALLATION

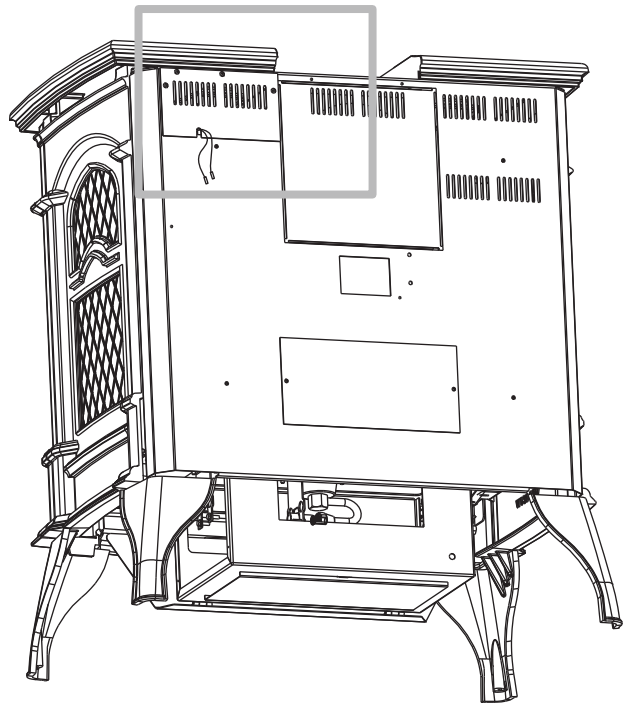
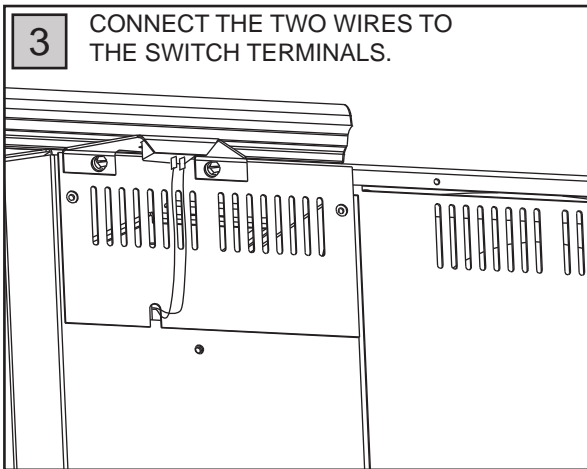
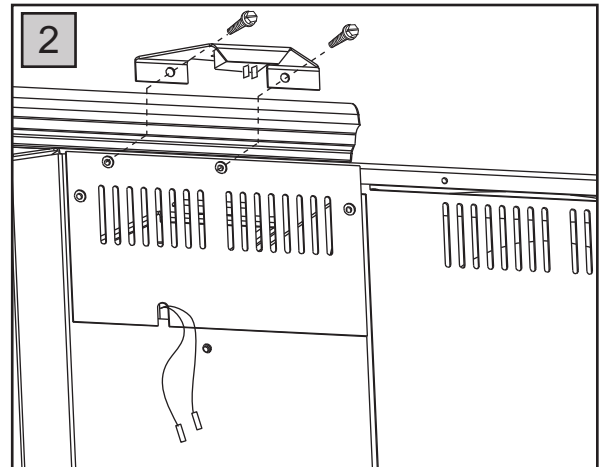
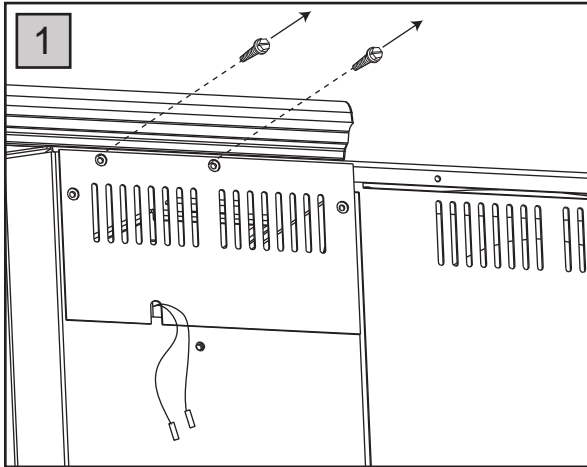

## 6.0 OPERATION

### **! WARNING**

**IF YOU DO NOT FOLLOW THESE INSTRUCTIONS EXACTLY, A FIRE OR EXPLOSION MAY RESULT CAUSING PROPERTY DAMAGE, PERSONAL INJURY OR LOSS OF LIFE.**

**IF APPLICABLE ALWAYS LIGHT THE PILOT WHETHER FOR THE FIRST TIME OR IF THE GAS SUPPLY HAS RUN OUT WITH THE GLASS DOOR OPENED OR REMOVED.**

**If appliance shuts off, do not relight until you provide fresh air. If appliance keeps shutting off, have it serviced. Keep burner and control compartment clean.**

When lit for the first time, the appliance will emit a slight odour for a few hours. This is a normal temporary condition caused by the curing of the logs and the "burn-in" of internal paints and lubricants used in the manufacturing process and will not occur again. After extended periods of non-operation such as following a vacation or a warm weather season, the appliance may emit a slight odour for a few hours. This is caused by dust particles burning off. In both cases, open a window to sufficiently ventilate the room.

#### FOR YOUR SAFETY READ BEFORE LIGHTING:

- This appliance is equipped with a pilot which must be lit by hand while following these instructions exactly.
- Before operating smell all around the appliance area for gas and next to the floor because some gas is heavier than air and will settle on the floor.
- Use only your hand to push in and turn the gas control knob. Never use tools. If the knob will not push in and turn by hand, do not try to repair it. Call a qualified service technician. Force or attempted repair may result in a fire or explosion.
- Do not use this appliance if any part has been under water. Immediately call a qualified service technician to inspect the appliance and replace any part of the control system and any gas control which has been under water.

#### WHAT TO DO IF YOU SMELL GAS:

- Do not try to light any appliance.
- Do not touch any electric switch; do not use any phone in your building.
- Immediately call your gas supplier from a neighbour's phone. Follow the gas supplier's instructions.
- If you cannot reach your gas supplier, call the fire department.

#### OXYGEN DEPLETION SENSOR

#### GAS KNOB

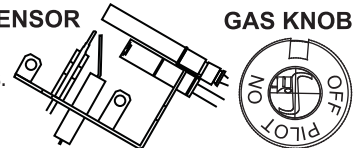

#### LIGHTING INSTRUCTIONS:

When lighting and re-lighting, the gas knob cannot be turned from pilot to off unless the knob is depressed.

- STOP! Read the above safety information on this label.
- Set the thermostat to lowest setting.
- Turn off all electric power to the appliance.
- Open the control door. Turn the gas knob clockwise to off.
- Wait five (5) minutes to clear out any gas. If you smell gas including near the floor, STOP! Follow "B" in the above safety information on this label. If you don't smell gas go to the next step.
- Find pilot located in front of the back log.
- Turn gas knob counter-clockwise to pilot.
- Depress and hold gas knob while lighting the pilot with the push button ignitor. Keep knob fully depressed for one minute, then release. If pilot does not continue to burn repeat steps 3 through 7.
- With pilot lit, turn gas knob counter-clockwise to on. When the pilot has been turned off, ignition of the main burner may be delayed from 1-2 minutes. When the pilot has been left burning, ignition of the main burner should occur almost immediately.
- If equipped with remote on-off switch, main burner may not come on when you turn the valve to on. Remote switch must be in the on position to ignite burner.
- Turn on all electric power to the appliance.

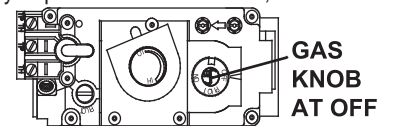

#### TO TURN OFF GAS

- Turn off all electric power to the appliance if service is to be performed.
- Push in gas control knob slightly and turn clockwise to off. Do not force.

## 7.0 ADJUSTMENT

### 7.1 VENTURI ADJUSTMENT

**! WARNING**

**CARBON CAN BE DISTRIBUTED IN SURROUNDING LIVING AREA IF THE AIR SHUTTER IS IMPROPERLY ADJUSTED.**

49.5

This appliance has an air shutter that has been factory set open according to the chart below:

Regardless of venturi orientation, closing the air shutter will cause a more yellow flame, but can lead to carboning. Opening the air shutter will cause a more blue flame, but can cause flame lifting from the burner ports. The flame may not appear yellow immediately; allow 15 to 30 minutes for the final flame colour to be established.

**AIR SHUTTER ADJUSTMENT MUST ONLY BE DONE BY A QUALIFIED INSTALLER!**

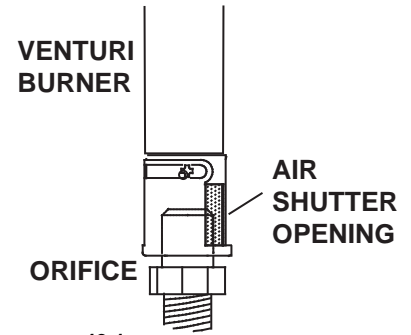

49.1

AIR SHUTTER OPENINGS	
NG	5/16" (0.313)
LP	5/16" (0.313)

### 7.2 FLAME CHARACTERISTICS

It's important to periodically perform a visual check of the pilot and burner flames. Compare them to the illustrations provided. If any flames appear abnormal call a service person.

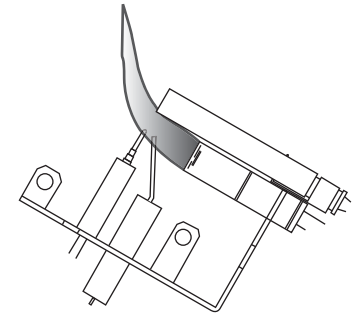
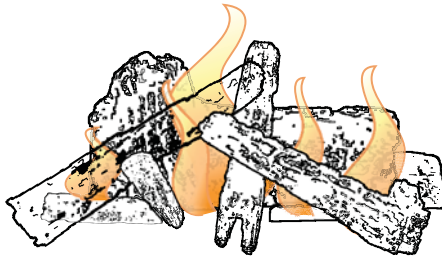

54.5



## 8.0 MAINTENANCE

<b>! WARNING</b>
<b>TURN OFF THE GAS AND ELECTRICAL POWER BEFORE SERVICING THE APPLIANCE.</b>
<b>APPLIANCE MAY BE HOT, DO NOT SERVICE UNTIL APPLIANCE HAS COOLED.</b>
<b>DO NOT USE ABRASIVE CLEANERS.</b>

**CAUTION:** Label all wires prior to disconnection when servicing controls. Wiring errors can cause improper and dangerous operation. Verify proper operation after servicing. This appliance and its venting system should be inspected before use and at least annually by a qualified service person. The appliance area must be kept clear and free of combustible materials, gasoline or other flammable vapors and liquids. The flow of combustion and ventilation air must not be obstructed.

1. In order to properly clean the burner and pilot assembly, remove the logs, rocks and/or glass to expose both assemblies.
2. Keep the control compartment, media, burner, air shutter opening and the area surrounding the logs clean by vacuuming or brushing, at least once a year.
3. Check to see that all burner ports are burning. Clean out any of the ports which may not be burning or are not burning properly.
4. Check to see that the pilot flame is large enough to engulf the flame sensor and/or thermocouple / thermopile as well as reaches the burner.
5. Replace the cleaned logs, rocks or glass. Failure to properly position the media may cause carboning which can be distributed in the surrounding living area.
6. Check to see that the main burner ignites completely on all openings when turned on. A 5 to 10 second total light-up period is satisfactory. If ignition takes longer, consult your local authorized dealer / distributor.

---

40.16

### 8.1 OXYGEN DEPLETION SENSOR PILOT CLEANING

This procedure must be performed by a qualified service person!  
Inspect the pilot for any visible contamination or debris (usually lint, pet hair, spider webs, carpet fibre, etc.) and remove.

Disconnect the pilot from the pilot tubing line, using a 7/16" wrench. Blow out the housing in the same direction as the gas flow. Re-install the pilot tube, turn on the gas and check for leaks.

If this does not improve the performance, replace the ODS with an exact replacement. The device is tamper resistant with no field serviceable parts.

**CORRECT PILOT FLAME**  
(Clean, stable, pronounced blue flame).

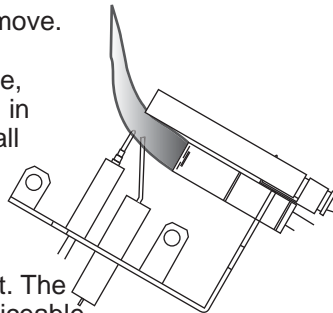

**INCORRECT PILOT FLAME**  
(Flame lifts upwards, becomes unstable with more of an orange tip).

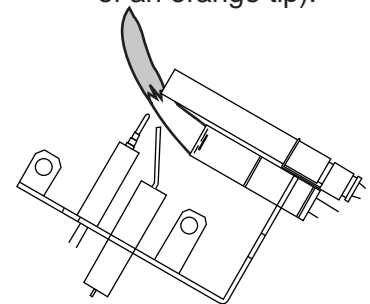

---

46.1

## 9.0 REPLACEMENTS

Contact your dealer or the factory for questions concerning prices and policies on replacement parts. Normally all parts can be ordered through your Authorized dealer / distributor.

**FOR WARRANTY REPLACEMENT PARTS, A PHOTOCOPY OF THE ORIGINAL INVOICE WILL BE REQUIRED TO HONOUR THE CLAIM.**

When ordering replacement parts always give the following information:

- Model & Serial Number of appliance
- Installation date of appliance
- Part number
- Description of part
- Finish

**\* IDENTIFIES ITEMS WHICH ARE NOT ILLUSTRATED. FOR FURTHER INFORMATION, CONTACT YOUR AUTHORIZED DEALER.**

### WARNING

**FAILURE TO POSITION THE PARTS IN ACCORDANCE WITH THIS MANUAL OR FAILURE TO USE ONLY PARTS SPECIFICALLY APPROVED WITH THIS APPLIANCE MAY RESULT IN PROPERTY DAMAGE OR PERSONAL INJURY.**

41.1

COMPONENTS		
REF	PART NO.	DESCRIPTION
1	W725-0030	SIT VALVE - NG
1	W725-0031	SIT VALVE - LP
2	W010-0757	BURNER
3	W456-0038	#38 BURNER ORIFICE - NG
3	W456-0053	#53 BURNER ORIFICE - LP
4	W662-0001	OXYGEN DEPLETION SENSOR SYSTEM - NG
4	W662-0005	OXYGEN DEPLETION SENSOR SYSTEM - LP
5*	W680-0004	THERMOPILE
6	W357-0001	PIEZO IGNITOR
7*	W660-0009	ON/OFF SWITCH
8*	W690-0002	THERMODISC
9	GL-646	LOG SET
10	W135-0209	LOG #1
11	W135-0082	CHARCOAL PIECE (LOG #2)
12	W135-0182	LOG #3
13	W135-0210	LOG #4
14	W135-0211	LOG #5
15	W135-0212	LOG #6
16	W135-0213	LOG #7
17*	W361-0079	GLOWING EMBERS
18*	W385-0334	NAPOLEON LOGO
19	W565-0110	SCREEN
20	W135-0384	BLACK TRIVET
21	W135-0377**	SIDE (LEFT OR RIGHT)
22	W135-0375**	TOP
23	W135-0376**	FRONT

ACCESSORIES		
REF	PART NO.	DESCRIPTION
24*	F50	THERMOSTATIC REMOTE
25*	GDSLL-KT	LEVELLING / SECURING KIT
26	GS-64KT	BLOWER KIT
27*	GS831C	CHROME TRIVET
28*	W550-0001	CHARCOAL EMBERS
29*	W380-0002	VARIABLE SPEED SWITCH KNOB
30	KB-35	VARIABLE SPEED SWITCH
31*	GDS819KT	DECORATIVE BRICK PANELS
32*	ANI-K	BLACK ANDIRONS
33*	ANI-O	OBELISK ANDIRONS

\*\*FOR OTHER AVAILABLE COLOURS, ADD THESE LETTERS TO THE BASE PART NUMBER:

COLOR	LETTER	FINISH
MAJOLICA BROWN	N	PORCELAIN
WROUGHT IRON	WI	PAINTED

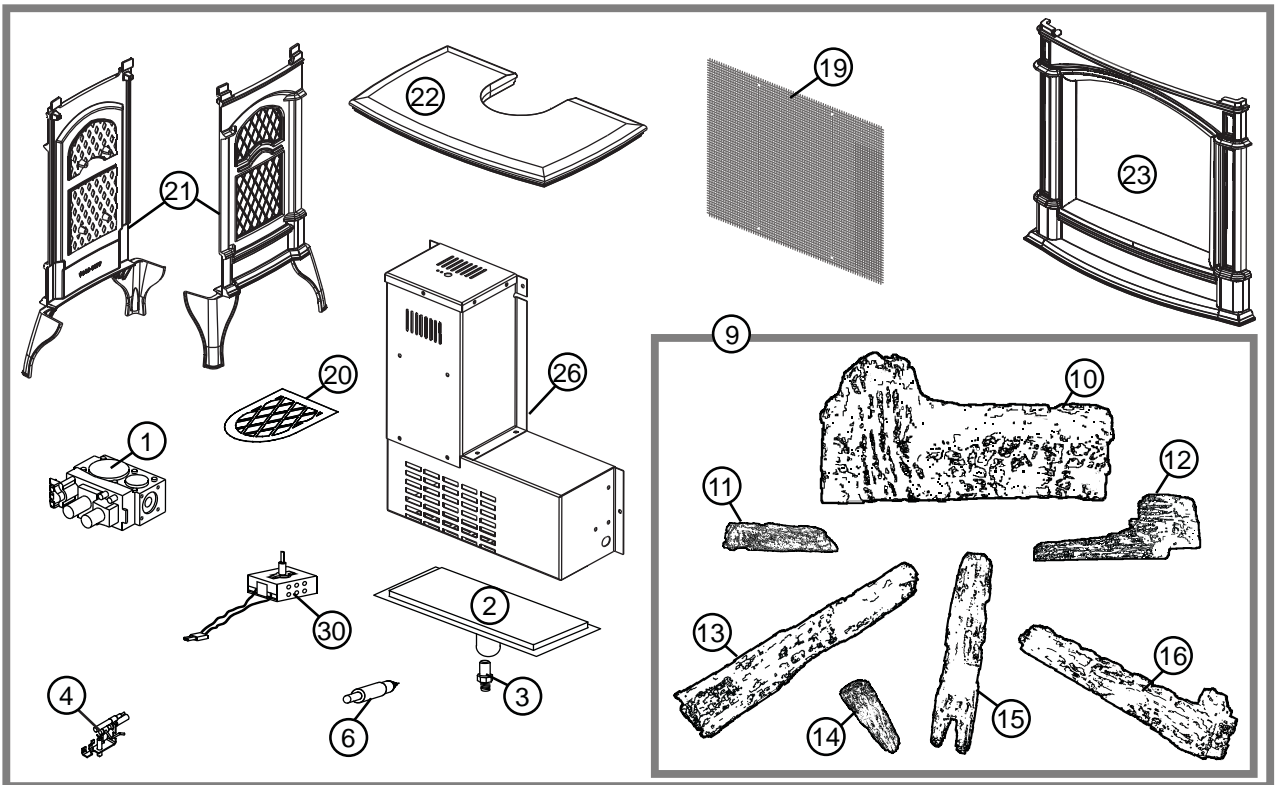

## 10.0 TROUBLESHOOTING

**! WARNING**

**ALWAYS LIGHT THE PILOT WHETHER FOR THE FIRST TIME OR IF THE GAS SUPPLY HAS RAN OUT, WITH THE GLASS DOOR OPEN OR REMOVED.**

**TURN OFF THE GAS AND ELECTRICAL POWER BEFORE SERVICING THE APPLIANCE.**

**APPLIANCE MAY BE HOT, DO NOT SERVICE UNTIL APPLIANCE HAS COOLED.**

**DO NOT USE ABRASIVE CLEANERS.**

<b>SYMPTOM</b>	<b>PROBLEM</b>	<b>TEST SOLUTION</b>
Main burner goes out; pilot stays on.	Pilot flame is not large enough or not engulfing the thermopile.	<ul style="list-style-type: none"> <li>- Ensure adequate supply pressure.</li> <li>- Replace pilot assembly.</li> </ul>
	Thermopile shorting / loose connection.	<ul style="list-style-type: none"> <li>- Clean thermopile connection to the valve. Reconnect.</li> <li>- Replace thermopile / valve.</li> </ul>
	Remote wall switch wire is too long; too much resistance in the system.	<ul style="list-style-type: none"> <li>- Shorten wire to connect length or wire gauge.</li> </ul>
	Faulty thermostat or switch.	<ul style="list-style-type: none"> <li>- Replace.</li> </ul>
Main burner goes out; pilot goes out.	Insufficient air supply.	<ul style="list-style-type: none"> <li>- Open window or door. (Use one of the methods described in ANSI Z223.1 / NFPA54 or the applicable local code.)</li> <li>- Have room checked for adequate air exchange.</li> <li>- See "COMBUSTION AND VENTILATION AIR PROVISIONS" section to ensure adequate air supply.</li> </ul>
	Out of propane gas.	<ul style="list-style-type: none"> <li>- Fill the tank.</li> </ul>
	Pilot flame is not large enough. (Supply pressure too low.)	<ul style="list-style-type: none"> <li>- Service or replace Oxygen Depletion Sensor System.</li> <li>- Correct piping and / or regulator to provide correct pressure.</li> <li>- Ensure adequate supply pressure.</li> </ul>
Pilot goes out when the gas knob is released. The gas valve has an interlock device which will not allow the pilot burner to be lit until the thermocouple has cooled. Allow approximately 60 seconds for the thermocouple to cool.	System is not correctly purged.	<ul style="list-style-type: none"> <li>- Purge the gas line.</li> </ul>
	Out of propane gas.	<ul style="list-style-type: none"> <li>- Fill the tank.</li> </ul>
	Pilot flame is not large enough. (Supply pressure too low.)	<ul style="list-style-type: none"> <li>- Service or replace Oxygen Depletion Sensor System.</li> </ul>
	Thermocouple shorting / faulty.	<ul style="list-style-type: none"> <li>- Loosen and tighten thermocouple.</li> <li>- Clean thermocouple and valve connection.</li> <li>- Replace Oxygen Depletion Sensor System.</li> <li>- Test and replace valve.</li> </ul>
	Faulty valve / high low knob does not depress smoothly.	<ul style="list-style-type: none"> <li>- Replace.</li> </ul>

42.4\_A

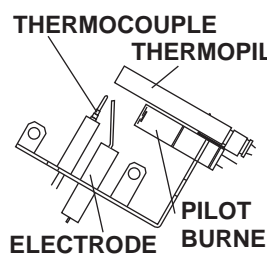
SYMPTOM	PROBLEM	TEST SOLUTION
Pilot burning; no gas to main burner; gas knob is on 'HI'; wall switch / thermostat is on.	Thermostat or switch is defective.	- Connect a jumper wire across the wall switch terminals; if main burner lights, replace switch / thermostat.
	Wall switch wiring is defective.	- Disconnect wires from valve. Connect a jumper wire across terminals 1 & 3; if the main burner lights, check the wires for defects and / or replace wires.
	Main burner orifice is plugged.	- Remove stoppage in orifice.
	Faulty valve.	- Replace.
Pilot will not light.	Out of propane gas.	- Fill the tank.
	No spark at pilot burner.	- Check if pilot can be lit by a match.
		- Check that the wire is connected to the push button ignitor.
		- Check if the push button ignitor needs tightening.
	- Replace the wire if the wire insulation is broken or frayed.	
	- Replace the electrode if the ceramic insulator is cracked or broken.	
	- Replace the push button ignitor.	
	- Replace the push button ignitor.	
Pilot goes out while standing; Main burner is in 'OFF' position.	No gas at the pilot burner.	- Check that the manual valve is turned on.
		- Check the pilot orifice for blockage.
		- Replace the valve / Oxygen Depletion Sensor System.
Pilot goes out while standing; Main burner is in 'OFF' position.	Gas piping is undersized.	- Call the gas distributor.
		- Turn on all gas appliances and see if pilot flame flutters, diminishes or extinguishes, especially when main burner ignites. Monitor appliance supply working pressure.
Pilot goes out while standing; Main burner is in 'OFF' position.	Pilot flame is not large enough.	- Check if supply piping size is to code. Correct all undersized piping.
	Inlet pressure too high. Pilot flame blowing off, missing thermopile.	- ODS Burner requires checking.
Main burner will not light; or is slow to light, noisy pilot.		Adjust inlet pressure to ensure maximum 7.0" W.C. at gas valve for natural gas and 13.0" W.C. for propane.
	Air shutter has become blocked.	- Ensure air shutter opening is free of lint or other obstructions.
	Flame is impinging on the glass, logs, rocks, media or combustion chamber.	- Check that the logs are correctly positioned.
	Flame is impinging on the glass, logs, rocks, media or combustion chamber.	- Check for ceiling or oscillating fans that may be influencing the flame.
Carbon is being deposited on glass, logs, rocks, media or combustion chamber.	Air shutter has become blocked.	- Open air shutter to increase the primary air. See "VENTURI ADJUSTMENT" section.
		- Check the input rate: check the manifold pressure and orifice size as specified by the rating plate.
		- Check the input rate: check the manifold pressure and orifice size as specified by the rating plate.

42.4\_2\_A

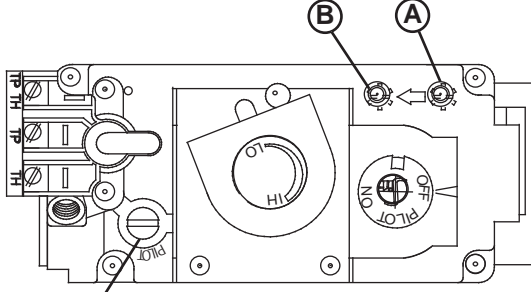
SYMPTOM	PROBLEM	TEST SOLUTION
<p>Flames are consistently too large or too small. Carboning occurs.</p>	<p>Unit is over-fired or under-fired.</p>	<ul style="list-style-type: none"> <li>- Check pressure readings:</li> <li>- Inlet pressure can be checked by turning screw (A) counter-clockwise 2 or 3 turns and then placing pressure gauge tubing over the test point. Check with burner operating on "HI". Gauge should read 7" (minimum 4.5") water column for natural gas or 13" (11" minimum) water column for propane.</li> <li>- Outlet pressure can be checked the same as above using screw (B). Check with burner operating on "HI". Gauge should read 3.5" water column for natural gas or 10" water column for propane.</li> <li>- <b>AFTER TAKING PRESSURE READINGS, BE SURE TO TURN SCREWS CLOCKWISE FIRMLY TO RESEAL. DO NOT OVER TORQUE.</b></li> <li>- Leak test with a soap and water solution.</li> </ul>
 <p style="text-align: center;"><b>PILOT SCREW</b></p>	<p>Air shutter improperly adjusted.</p>	<ul style="list-style-type: none"> <li>- Return air shutter to specified opening, see "VENTURI ADJUSTMENT" section.</li> </ul>
	<p>Exhaust fumes smelled in room, headaches.</p>	<p>Not enough combustion air.</p>
	<p>Not enough ventilation air.</p>	<ul style="list-style-type: none"> <li>- Increase fresh air supply. (Use one of the methods described in ANSI Z223.1 / NFPA 54 or the applicable local code.)</li> </ul>
	<p>Flame is impinging on the logs or combustion chamber.</p>	<ul style="list-style-type: none"> <li>- Check that the logs are correctly positioned.</li> <li>- Open air shutter to increase the primary air. See "VENTURI ADJUSTMENT" section.</li> <li>- Check the input rate: check the manifold pressure and orifice size as specified by the rating plate values.</li> </ul>
<p>Remote wall switch is in "off" position; main burner comes on when gas knob is turned to "ON" position.</p>	<p>Wall switch is mounted upside down.</p>	<ul style="list-style-type: none"> <li>- Reverse.</li> </ul>
	<p>Remote wall switch is grounding.</p>	<ul style="list-style-type: none"> <li>- Replace.</li> </ul>
	<p>Remote wall switch wire is grounding.</p>	<ul style="list-style-type: none"> <li>- Check for ground (short); repair ground or replace wire.</li> </ul>
	<p>Faulty valve.</p>	<ul style="list-style-type: none"> <li>- Replace.</li> </ul>
<p>If optional catalytic door is used, White / grey film forms on the glass.</p>	<p>Sulphur from fuel is being deposited on the glass, logs, rocks, media or combustion surfaces.</p>	<ul style="list-style-type: none"> <li>- Clean glass with recommended gas appliance glass cleaner. <b>DO NOT CLEAN GLASS WHEN HOT!</b></li> <li>- If deposits are not cleaned off regularly, the glass may become permanently marked.</li> </ul>

## 11.0 WARRANTY

NAPOLEON® products are manufactured under the strict Standard of the world recognized ISO 9001 : 2008 Quality Assurance Certificate.

NAPOLEON® products are designed with superior components and materials assembled by trained craftsmen who take great pride in their work. The burner and valve assembly are leak and test-fired at a quality test station. The complete appliance is again thoroughly inspected by a qualified technician before packaging to ensure that you, the customer, receives the quality product that you expect from NAPOLEON®.

### NAPOLEON® GAS APPLIANCE PRESIDENT'S LIFETIME LIMITED WARRANTY

The following materials and workmanship in your new NAPOLEON® gas appliance are warranted against defects for as long as you own the appliance. This covers: combustion chamber, heat exchanger, stainless steel burner, phazer™ logs and embers, rocks, ceramic glass (thermal breakage only), gold plated parts against tarnishing, porcelainized enameled components and aluminum extrusion trims.\*

Electrical (110V and millivolt) components and wearable parts such as blowers, gas valves, thermal switch, switches, wiring, remote controls, ignitor, gasketing, and pilot assembly are covered and NAPOLEON® will provide replacement parts free of charge during the first year of the limited warranty.\*

Labour related to warranty repair is covered free of charge during the first year. Repair work, however, requires the prior approval of an authorized company official. Labour costs to the account of NAPOLEON® are based on a predetermined rate schedule and any repair work must be done through an authorized NAPOLEON® dealer.

\* Construction of models vary. Warranty applies only to components included with your specific appliance.

### CONDITIONS AND LIMITATIONS

NAPOLEON® warrants its products against manufacturing defects to the original purchaser only. Registering your warranty is not necessary. Simply provide your proof of purchase along with the model and serial number to make a warranty claim. NAPOLEON® reserves the right to have its representative inspect any product or part thereof prior to honouring any warranty claim. Provided that the purchase was made through an authorized NAPOLEON® dealer your appliance is subject to the following conditions and limitations:

Warranty coverage begins on the date of original installation.

This factory warranty is non-transferable and may not be extended whatsoever by any of our representatives.

The gas appliance must be installed by a licensed, authorized service technician or contractor. Installation must be done in accordance with the installation instructions included with the product and all local and national building and fire codes.

This limited warranty does not cover damages caused by misuse, lack of maintenance, accident, alterations, abuse or neglect and parts installed from other manufacturers will nullify this warranty.

This limited warranty further does not cover any scratches, dents, corrosion or discoloring caused by excessive heat, abrasive and chemical cleaners nor chipping on porcelain enamel parts, mechanical breakage of PHAZER™ logs and embers.

This warranty extends to the repair or replacement of warranted parts which are defective in material or workmanship provided that the product has been operated in accordance with the operation instructions and under normal conditions.

After the first year, with respect to this President's Lifetime Limited Warranty, NAPOLEON® may, at its discretion, fully discharge all obligations with respect to this warranty by refunding to the original warranted purchaser the wholesale price of any warranted but defective part(s).

NAPOLEON® will not be responsible for installation, labour or any other expenses related to the reinstallation of a warranted part and such expenses are not covered by this warranty.

Notwithstanding any provisions contained in the President's Lifetime Limited Warranty, NAPOLEON'S responsibility under this warranty is defined as above and it shall not in any event extend to any incidental, consequential or indirect damages.

This warranty defines the obligations and liability of NAPOLEON® with respect to the NAPOLEON® gas appliance and any other warranties expressed or implied with respect to this product, its components or accessories are excluded.

NAPOLEON® neither assumes, nor authorizes any third party to assume, on its behalf, any other liabilities with respect to the sale of this product.

NAPOLEON® will not be responsible for: over-firing, downdrafts, spillage caused by environmental conditions such as rooftops, buildings, nearby trees, hills, mountains, inadequate vents or ventilation, excessive venting configurations, insufficient makeup air, or negative air pressures which may or may not be caused by mechanical systems such as exhaust fans, furnaces, clothes dryers, etc.

Any damages to the appliance, combustion chamber, heat exchanger, plated trim or other components due to water, weather damage, long periods of dampness, condensation, damaging chemicals or cleaners will not be the responsibility of NAPOLEON®.

All parts replaced under the President's Limited Lifetime Warranty Policy are subject to a single claim.

During the first 10 years NAPOLEON® will replace or repair the defective parts covered by the lifetime warranty at our discretion free of charge. From 10 years to life, NAPOLEON® will provide replacement parts at 50% of the current retail price.

All parts replaced under the warranty will be covered for a period of 90 days from the date of their installation.

The manufacturer may require that defective parts or products be returned or that digital pictures be provided to support the claim. Returned products are to be shipped prepaid to the manufacturer for investigation. If a product is found to be defective, the manufacturer will repair or replace such defect.

Before shipping your appliance or defective components, your dealer must obtain an authorization number. Any merchandise shipped without authorization will be refused and returned to sender.

Shipping costs are not covered under this warranty.

Additional service fees may apply if you are seeking warranty service from a dealer.

Warranty labour allowance is only for the replacement of the warranted part. Travel, diagnostic tests, shipping and other related charges are not covered by this warranty.

ALL SPECIFICATIONS AND DESIGNS ARE SUBJECT TO CHANGE WITHOUT PRIOR NOTICE DUE TO ON-GOING PRODUCT IMPROVEMENTS. NAPOLEON® IS A REGISTERED TRADEMARK OF WOLF STEEL LTD.

# 12.0 SERVICE HISTORY

**Appliance Service History**  
This heater must be serviced annually depending on usage.

Date	Dealer Name	Service Technician Name	Service Performed	Special Concerns