



WIRING DIAGRAMS

gas-fired, power vented and separated combustion unit heaters
for models HD/HDB, HDS/HDC, PTP, PTS/BTS, PTC/BTC - Before 10/2014



WARNING

1. Fuel supply shall be shut-off and the electrical power disconnected before proceeding with the installation. Failure to do so could result in fire, explosion, electrical shock, or the unit starting suddenly resulting in injury.
2. All units must be wired strictly in accordance with wiring diagram furnished with the unit. Failure to wire this unit according to this wiring diagram could result in a hazard to persons and property. For deviations, contact the factory.
3. All wiring must be done with a wiring material having a temperature rating of at least 105°C.

IMPORTANT

1. The use of this manual is specifically intended for a qualified installation and service agency. All installation and service of these kits must be performed by a qualified installation and service agency.
2. These instructions must also be used in conjunction with the Installation and Service manual originally shipped with the appliance being converted, in addition to any other accompanying component supplier literature which supersedes these instructions.

Diagram Selection

Diagrams are provided for both single and three-phase circuits, and are readily identified in the selection table on page 2. The selection table enables easy selection of the correct wiring diagram after the electrical components of the unit heater have been determined.

NOTE: As indicated in every diagram, all wiring must comply with the National Electrical Code and all local codes. All components must agree with their respective power source.

Abbreviations and Symbols

To facilitate interpretation and enable simplification the abbreviations and symbols have been selected as recommended by ANSI (American National Standards Institute) and NEMA (National Electrical Manufacturers Association) standards.

XFMR or TR	Transformer
H1, H2, etc.	Transformer Primary Terminals
X1, X2, etc.	Transformer Secondary Terminals
V	Volts
Hz	Hertz
∅	Phase
RC	Relay Contactor Coil
G	Ground
H	Hot
SW	Switch
HI	High
LO	Low
C	Common
"J" Box	Junction Box
S/W	Summer/Winter Switch
O.L.C.	Overload Contacts
SPDT	Single Pole Double Throw Switch
DPDT	Double Pole Double Throw Switch
VA	Volt-Ampere
L1, L2, L3	Load Terminals (Connect to Supply Voltage)
T1, T2, T3	Motor or Motor Starter Terminals
Wire Color Coding	
BK	Black
BR	Brown
BL	Blue
R	Red
W	White
GY	Gray
Y	Yellow

THIS MANUAL IS THE PROPERTY OF THE OWNER.
PLEASE BE SURE TO LEAVE IT WITH THE OWNER WHEN YOU LEAVE THE JOB.

Modine Manufacturing Company has a continuous product improvement program, and therefore reserves the right to change design and specifications without notice.

WIRING DIAGRAM – SELECTION

Select the correct wiring diagram as follows:

1. Determine the 16 digit unit heater model number. Example: PTS350SS0122SBAN
2. Breakdown the model number into the following parts (using the above example):
 - a. Model: PTS
 - b. Size: 350
 - c. Power Code: 01
 - d. Control Code: 22
 - e. Factory Option: N
3. Review the model number breakdown against Table 2.1 to select the correct wiring diagram.
For the example in Step 2 above, the correct wiring diagram is located on page 6.
4. Review Table 2.2 to determine if any additional wiring diagrams are necessary based on accessories included.

Table 2.1 – Unit Heater Wiring Diagram Page Location Index

Type	Model	Size	Power Code	Supply Voltage	Control Code	Gas Controls	Wiring Diagram	Page
Propeller	HD/HDS	30-125	01 ①	115V/1ph	11 or 21	Single Stage	5H0799630001	3
					12 or 22	Two Stage	5H0799630002	4
	PTP/PTS	150-350	01 ①	115V/1ph	11 or 21	Single Stage	5H0799630001	3
					12 or 22	Two Stage	5H0799630002	4
		400	01 ①	115V/1ph	11 or 21	Single Stage	5H0799630003	5
					12 or 22	Two Stage	5H0799630004	6
	PTC	55-215	01 ①	115V/1ph	11 or 21	Single Stage	5H0807160001	11
		260-310	01 ①	115V/1ph	11 or 21	Single Stage	5H0807160002	12
Blower	HDB/HDC	60-125	01 ②	115V/1ph	11 or 21	Single Stage	5H0799630001	3
					12 or 22	Two Stage	5H0799630002	4
	BTS	150	01 ②	115V/1ph	11 or 21	Single Stage	5H0799630001	3
					12 or 22	Two Stage	5H0799630002	4
		150-400	02, 13, 24,35 ②	115/230V/1ph	11 or 21	Single Stage	5H0802730001	7
					12 or 22	Two Stage	5H0802730002	8
					11 or 21	Single Stage	5H0802740001	9
					12 or 22	Two Stage	5H0802740002	10
	BTC	215-310	02, 13, 24, 35, 46, 57 ②	115/230V/1ph	11 or 21	Single Stage	5H0807160003	13
					08, 11, 19, 22, 30, 33, 41, 44, 52, 55, 63, 66, 74, 77, 80, 83, 84, 85 ②	208/230/460/575V/3ph	11 or 21	Single Stage

① All propeller models (HD/HDS/PTP/PTS/PTC) are Power Code 01 for 115V/60Hz/1ph supply voltage only. To operate the unit on a supply voltage other than 115V/1ph, an accessory step down transformer is required. Refer to the latest revision of Literature #6-567 for instructions on properly wiring the unit heater and transformer.

② All blower models (HDB/HDC/BTS/BTC) that are operated with a supply voltage other than 115V/1ph, an accessory step down transformer is required. Refer to the latest revision of Literature #6-567 for instructions on properly wiring the unit heater and transformer.

Table 2.2 – Accessory Wiring Diagram Page Location Index

Model	Accessory	Page
All	Thermostat with Fan On/Auto Subbase Switching	15
All	Thermostat without Fan On/Auto Subbase Switching and Summer/Winter Switch	15
All	Wiring Multiple Single Stage Unit Heaters to a Single Thermostat	16
PTC	Terminal Board Jumper Removal for Accessory Wiring	16

WIRING DIAGRAMS – MODELS HD/HDB, HDS/HDC, PTP, PTS/BTS

115V Unit Power

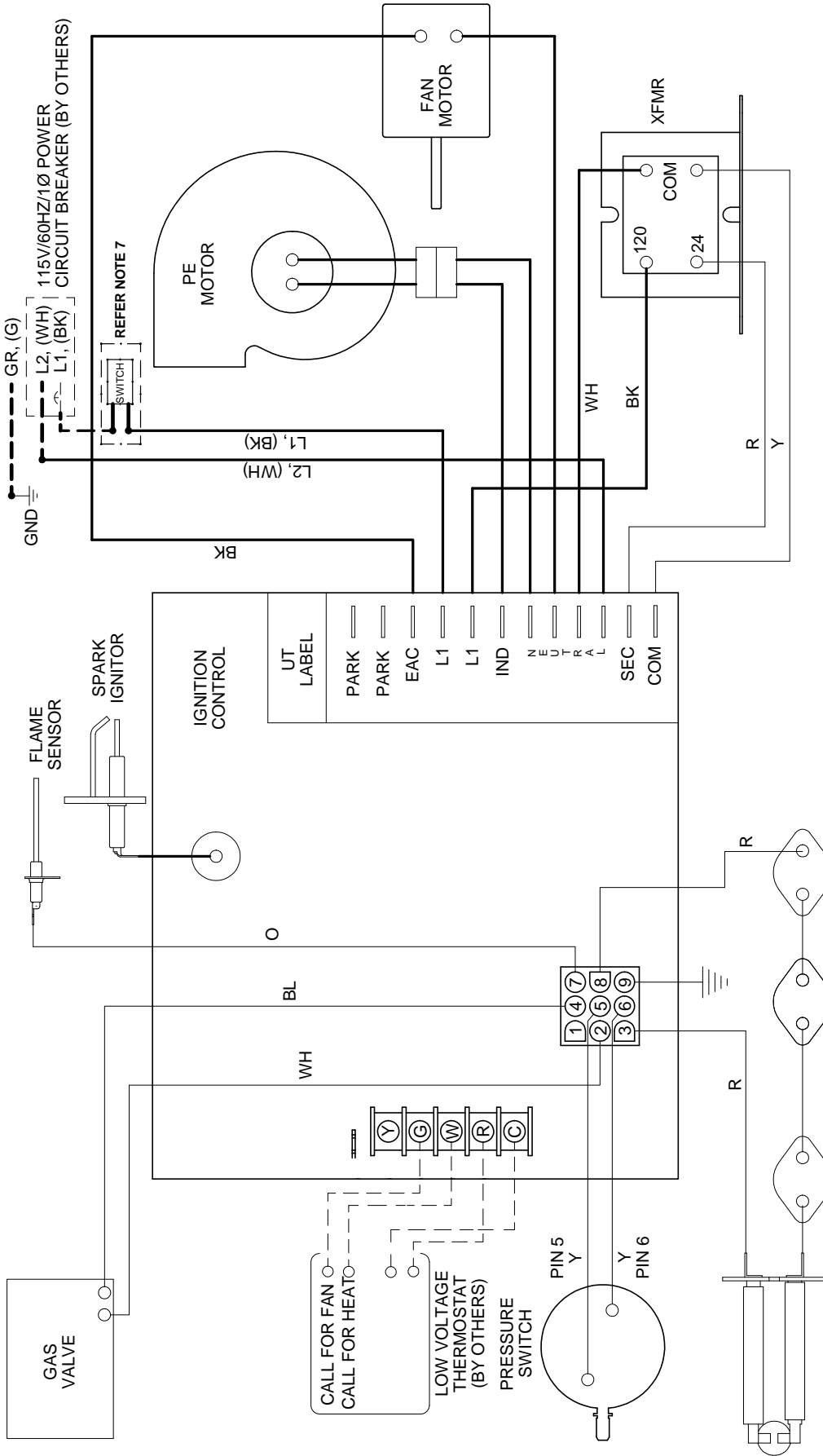

NOTES TO INSTALLER: 5H0799630001 REV J

1. ALL WIRING MUST COMPLY WITH NATIONAL ELECTRIC CODE AND ALL LOCAL CODES.
2. ALL COMPONENTS MUST AGREE WITH THEIR RESPECTIVE POWER SOURCE.
3. VERIFY THE POWER SOURCE AND THE UNIT POLARITY.
4. USE TYPE 105°C REPLACEMENT WIRE 300V OR GREATER.
5. USED ON PROPELLER MODELS 100 AND LARGER.
6. TWO SWITCHES: 30-75, ONE SWITCH: 100-125 NOT USED ON 150-400 UNITS.
7. OPTIONAL UNIT DISCONNECT SWITCH.

FOR BLOWER MOTORS, ATTACH WIRES NOT USED:

- WH-NEUTRAL
- BK-HI
- BL-MED
- RED-LO
- TO "PARK" TERMINALS

FLAME ROLLOUTS (SEE NOTE 6)

LIMIT CONTROL (SEE NOTE 5)

LIMIT CONTROL

CAUTION: FAILURE TO WIRE THIS UNIT ACCORDING TO THIS WIRING DIAGRAM MAY RESULT IN INJURY TO THE INSTALLER OR USER. FOR DEVIATIONS CONTACT THE FACTORY.

WIRING DIAGRAMS – MODELS HD/HDB, HDS/HDC, PTP, PTS/BTS

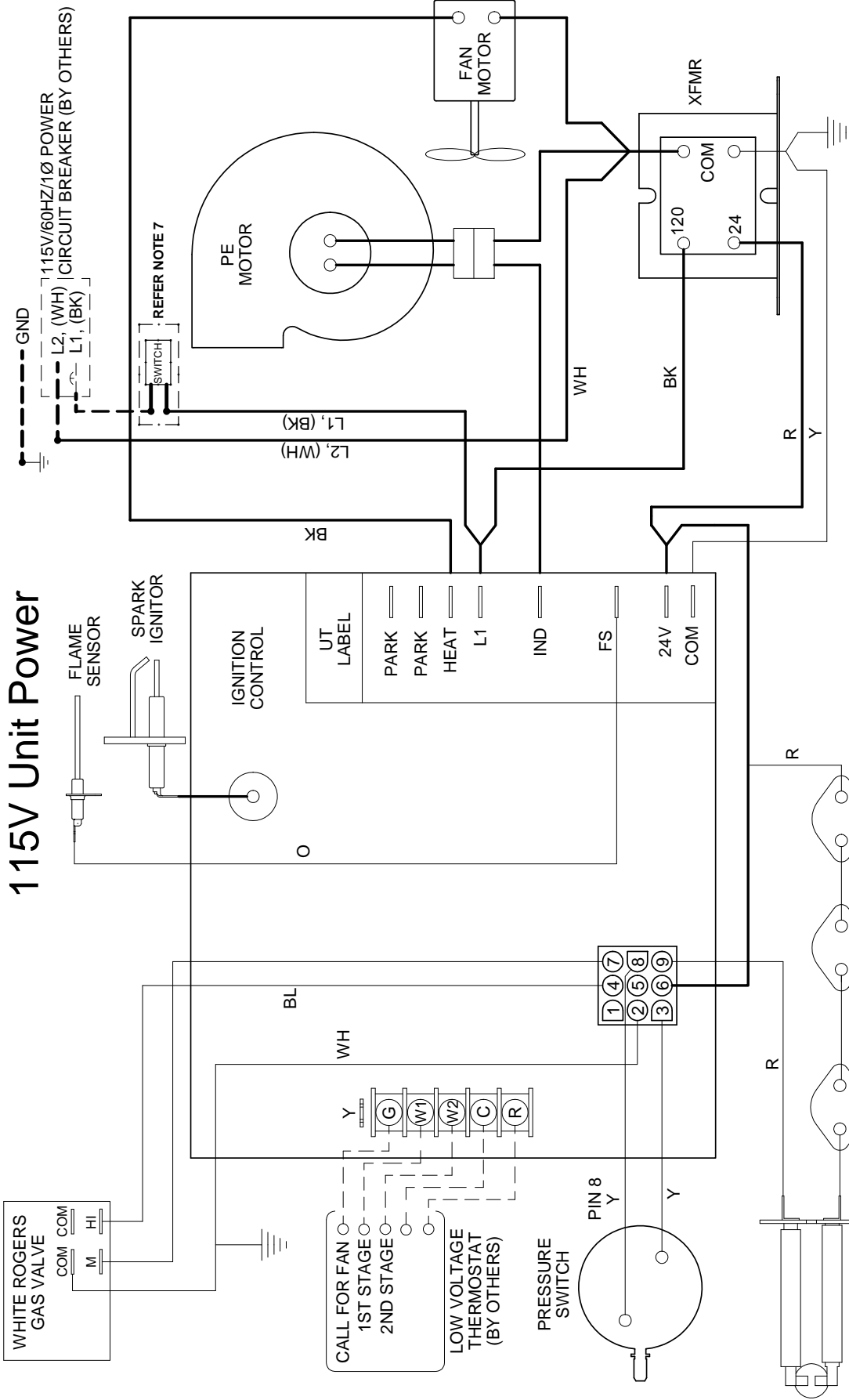

115V Unit Power

5H0799630002 REV J

NOTES TO INSTALLER:

1. ALL WIRING MUST COMPLY WITH NATIONAL ELECTRIC CODE AND ALL LOCAL CODES.
2. ALL COMPONENTS MUST AGREE WITH THEIR RESPECTIVE POWER SOURCE.
3. VERIFY THE POWER SOURCE AND THE UNIT POLARITY.
4. USE TYPE 105°C REPLACEMENT WIRE 300V OR GREATER.
5. USED ON PROPELLER MODELS 100 AND LARGER.
6. TWO SWITCHES: 30-75, ONE SWITCH: 100-125 NOT USED ON 150-400 UNITS.
7. OPTIONAL UNIT DISCONNECT SWITCH.

FOR BLOWER MOTORS, ATTACH WIRES NOT USED:

- WH-NEUTRAL
- BK-HI
- BL-MED
- RED-LO
- TO "PARK" TERMINALS

FLAME ROLLOUTS (SEE NOTE 6)

LIMIT CONTROL (SEE NOTE 5)

LIMIT CONTROL

CAUTION: FAILURE TO WIRE THIS UNIT ACCORDING TO THIS WIRING DIAGRAM MAY RESULT IN INJURY TO THE INSTALLER OR USER. FOR DEVIATIONS CONTACT THE FACTORY.

WIRING DIAGRAM – MODELS HD/HDB, HDS/HDC, PTP, PTS/BTS

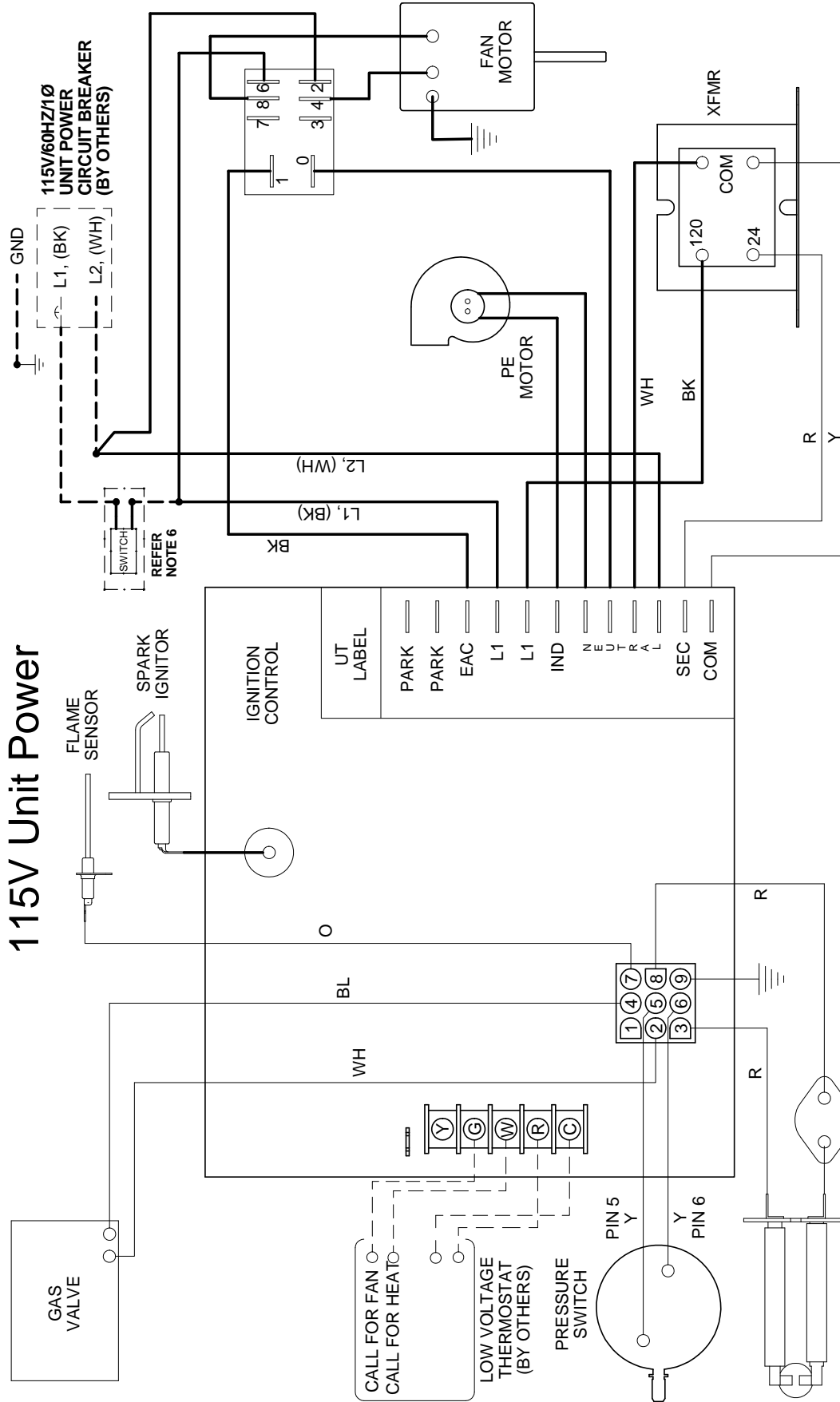

115V Unit Power

NOTES TO INSTALLER: 5H0799630003 REV J

1. ALL WIRING MUST COMPLY WITH NATIONAL ELECTRIC CODE AND ALL LOCAL CODES.
2. ALL COMPONENTS MUST AGREE WITH THEIR RESPECTIVE POWER SOURCE.
3. VERIFY THE POWER SOURCE AND THE UNIT POLARITY.
4. USE TYPE 105°C REPLACEMENT WIRE 300V OR GREATER.
5. USED ON PROPELLER MODELS 100 AND LARGER.
6. OPTIONAL UNIT DISCONNECT SWITCH.

FOR BLOWER MOTORS,

- WH-NEUTRAL
- BK-HI
- BL-MED
- RED-LO

ATTACH WIRES NOT USED TO "PARK" TERMINALS

CAUTION:
FAILURE TO WIRE THIS UNIT ACCORDING TO THIS WIRING DIAGRAM MAY RESULT IN INJURY TO THE INSTALLER OR USER.
FOR DEVIATIONS CONTACT THE FACTORY.

WIRING DIAGRAMS – MODELS HD/HDB, HDS/HDC, PTP, PTS/BTS

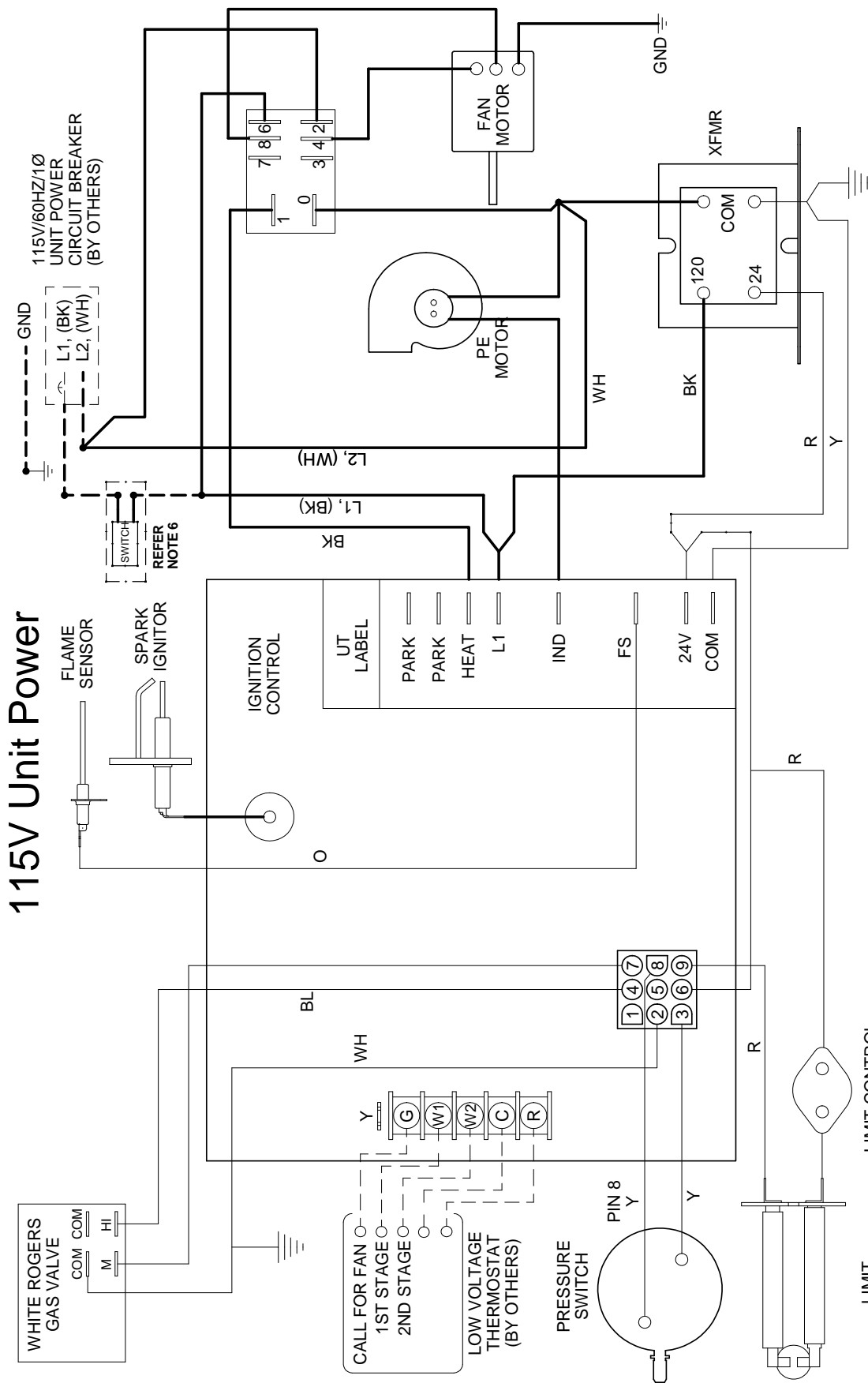

115V Unit Power

5H0799630004 REV J

NOTES TO INSTALLER:

1. ALL WIRING MUST COMPLY WITH NATIONAL ELECTRIC CODE AND ALL LOCAL CODES.
2. ALL COMPONENTS MUST AGREE WITH THEIR RESPECTIVE POWER SOURCE.
3. VERIFY THE POWER SOURCE AND THE UNIT POLARITY.
4. USE TYPE 105°C REPLACEMENT WIRE 300V OR GREATER.
5. USED ON PROPELLER MODELS 100 AND LARGER.
6. OPTIONAL UNIT DISCONNECT SWITCH.

FOR BLOWER MOTORS,

- WH-NEUTRAL
- BK-HI
- BL-MED
- RED-LO

ATTACH WIRES NOT USED TO "PARK" TERMINALS

CAUTION:
FAILURE TO WIRE THIS UNIT ACCORDING TO THIS WIRING DIAGRAM MAY RESULT IN INJURY TO THE INSTALLER OR USER.
FOR DEVIATIONS CONTACT THE FACTORY.

WIRING DIAGRAM – MODELS HD/HDB, HDS/HDC, PTP, PTS/BTS

115V Unit Power

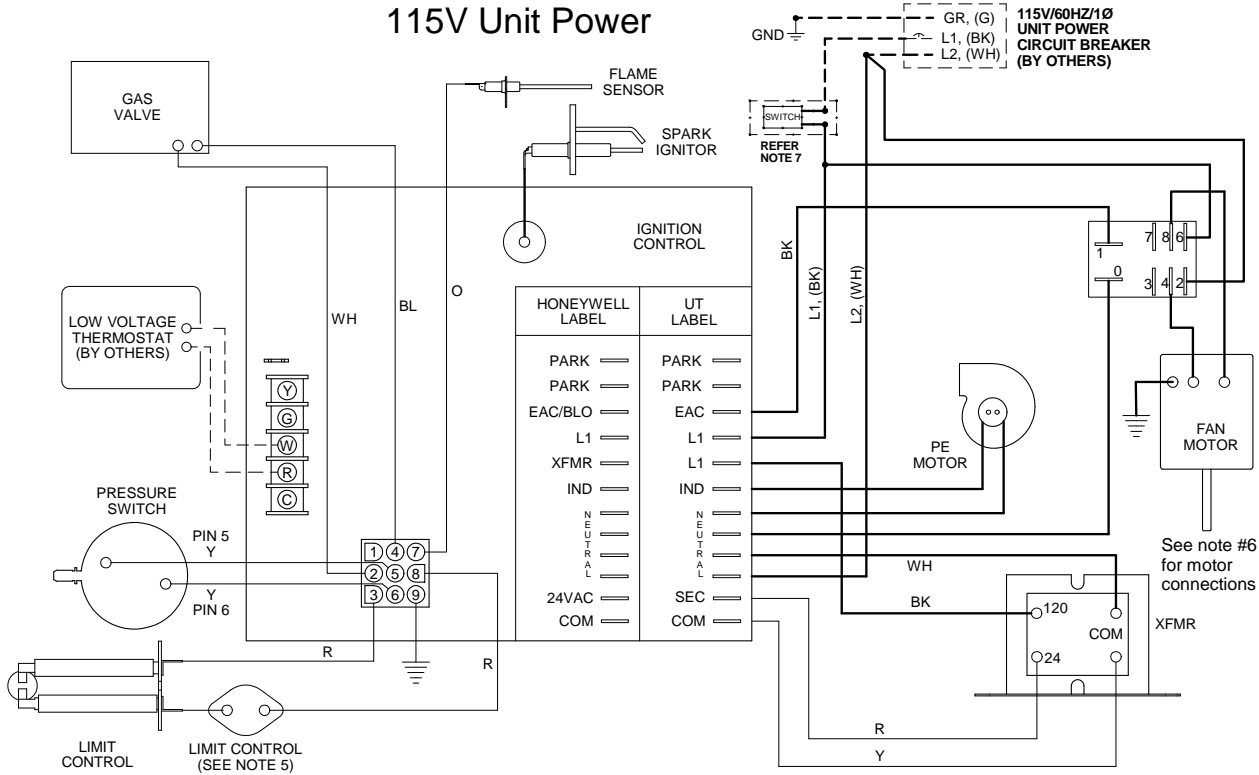

>Disconnect relay power leads (#2 & #6) from 115V supply and connect 230V as shown.
>All other unit power must be 115V as shown.
>See note #6 for motor connections.

230V Fan/Blower Power Only

CONTROL CIRCUIT MUST BE 115V POWER

230V/60HZ/1Ø FAN CIRCUIT POWER CIRCUIT BREAKERS (BY OTHERS)
L2, (BL)
L1, (BK)
GND

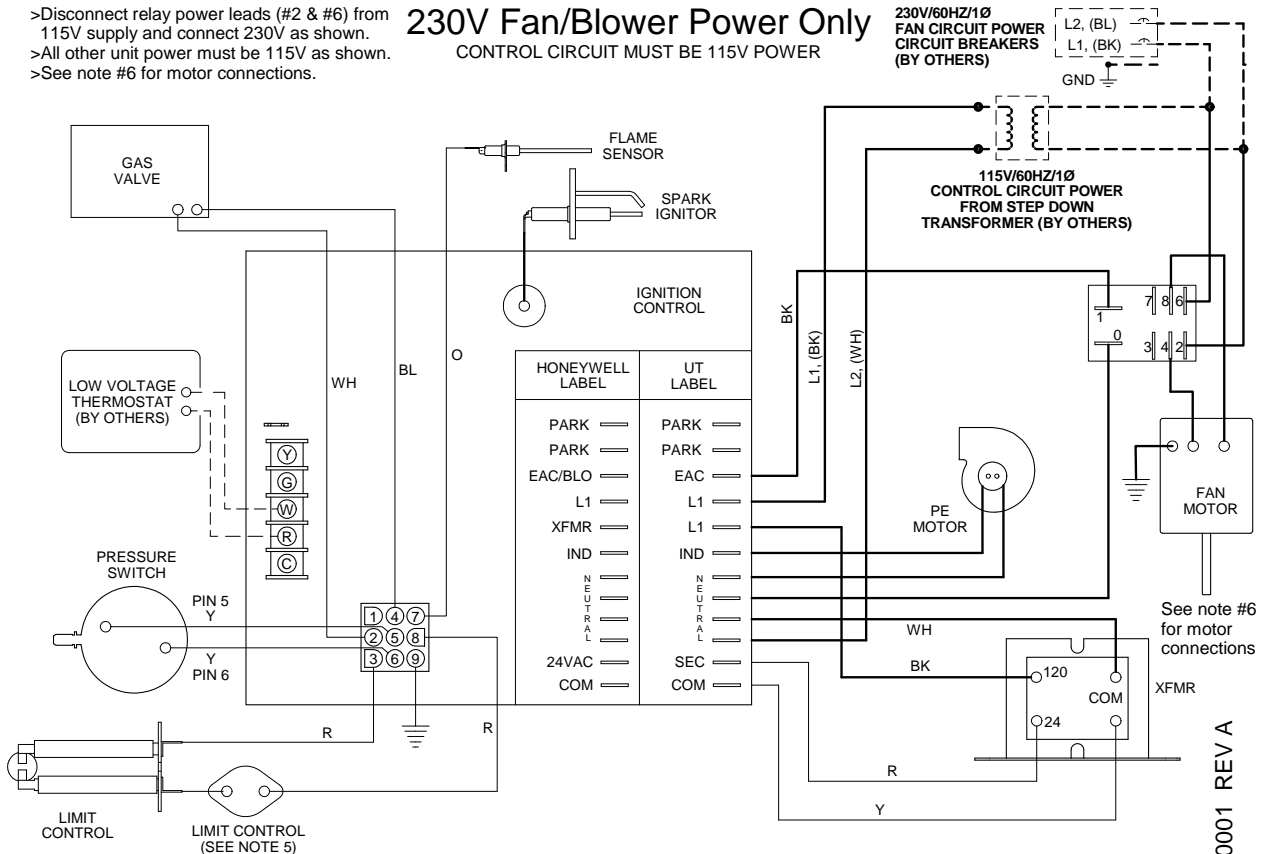

CAUTION:
FAILURE TO WIRE THIS UNIT ACCORDING TO THIS WIRING DIAGRAM MAY RESULT IN INJURY TO THE INSTALLER OR USER. FOR DEVIATIONS CONTACT THE FACTORY.

- NOTES TO INSTALLER:**
1. ALL WIRING MUST COMPLY WITH ALL NATIONAL ELECTRIC AND LOCAL CODES.
 2. ALL COMPONENTS MUST AGREE WITH THEIR RESPECTIVE POWER SOURCE.
 3. VERIFY THE POWER SOURCE AND THE UNIT POLARITY.
 4. USE TYPE 105°C REPLACEMENT WIRE 300V OR GREATER.
 5. RELAY USED ON SINGLE PHASE MOTORS WITH LARGER AMP DRAWS.
 6. UNIT IS SHIPPED WIRED FOR 115V. WHEN WIRING FOR 230V FOLLOW THIS DIAGRAM AND MOTOR WIRE LABELS FOR 230V.
 7. OPTIONAL UNIT DISCONNECT SWITCH USED ON 115V UNITS ONLY.

5H0802730001 REV A

WIRING DIAGRAMS – MODELS HD/HDB, HDS/HDC, PTP, PTS/BTS

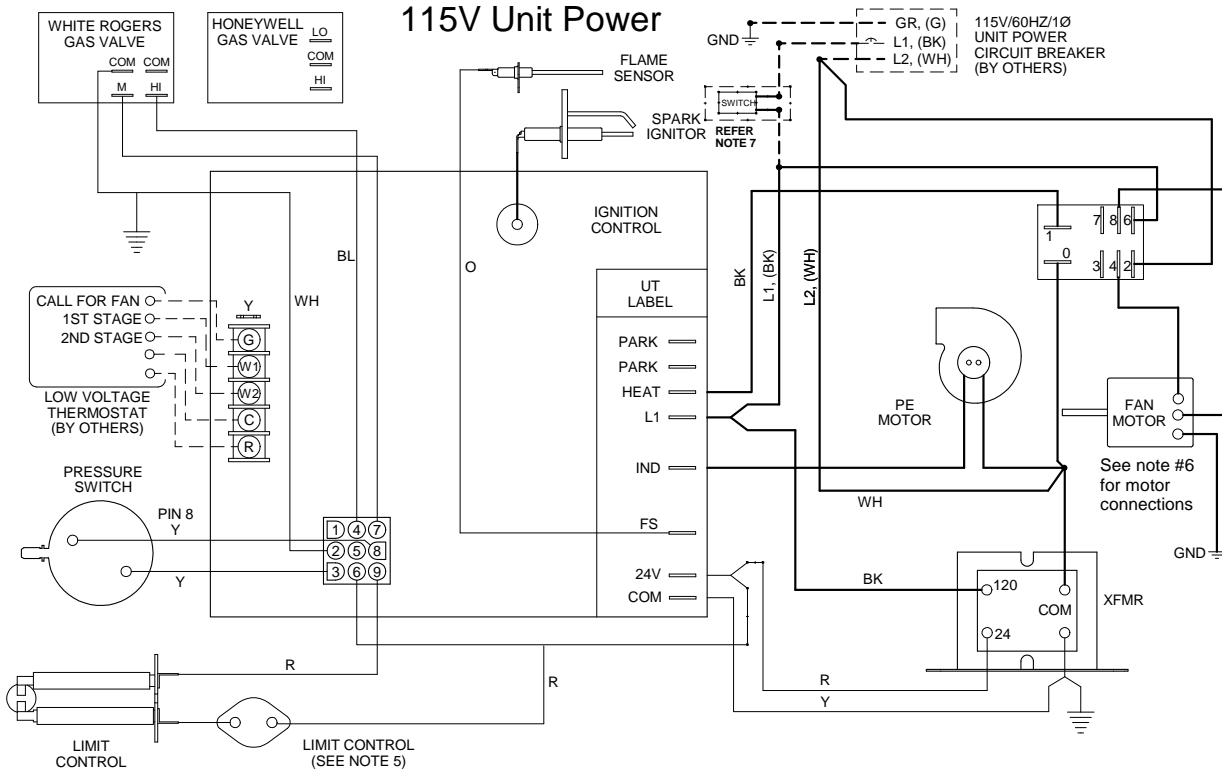

>Disconnect relay power leads (#2 & #6) from 115V supply and connect 230V as shown.
 >All other unit power must be 115V as shown.
 >See note #6 for motor connections.

230V Fan/Blower Power Only

CONTROL CIRCUIT MUST BE 115V POWER

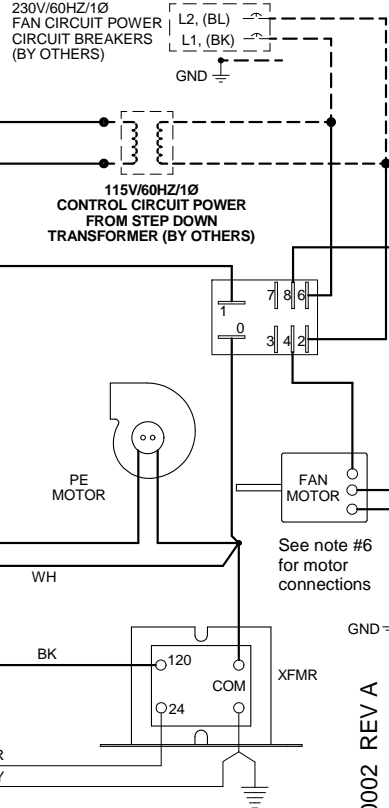

CAUTION:
 FAILURE TO WIRE THIS UNIT ACCORDING TO THIS WIRING DIAGRAM MAY RESULT IN INJURY TO THE INSTALLER OR USER. FOR DEVIATIONS CONTACT THE FACTORY.

- NOTES TO INSTALLER:**
1. ALL WIRING MUST COMPLY WITH ALL NATIONAL ELECTRIC AND LOCAL CODES.
 2. ALL COMPONENTS MUST AGREE WITH THEIR RESPECTIVE POWER SOURCE.
 3. VERIFY THE POWER SOURCE AND THE UNIT POLARITY.
 4. USE TYPE 105°C REPLACEMENT WIRE 300V OR GREATER.
 5. RELAY USED ON SINGLE PHASE MOTORS WITH LARGER AMP DRAWS.
 6. UNIT IS SHIPPED WIRED FOR 115V. WHEN WIRING FOR 230V FOLLOW THIS DIAGRAM AND MOTOR WIRE LABELS FOR 230V.
 7. OPTIONAL UNIT DISCONNECT SWITCH USED ON 115V UNITS ONLY.

5H0802730002 REV A

WIRING DIAGRAMS – MODELS HD/HDB, HDS/HDC, PTP, PTS/BTS

5H0802740001 REV B

NOTES TO INSTALLER:

1. ALL WIRING MUST COMPLY WITH NATIONAL ELECTRIC CODE AND ALL LOCAL CODES.
2. ALL COMPONENTS MUST AGREE WITH THEIR RESPECTIVE POWER SOURCE.
3. VERIFY THE POWER SOURCE AND THE UNIT POLARITY.
4. USE TYPE 105°C REPLACEMENT WIRE 300V OR GREATER.
5. MAKE MOTOR CONNECTIONS PER THE MOTOR WIRE DIAGRAM.
6. OPTIONAL UNIT DISCONNECT SWITCH.

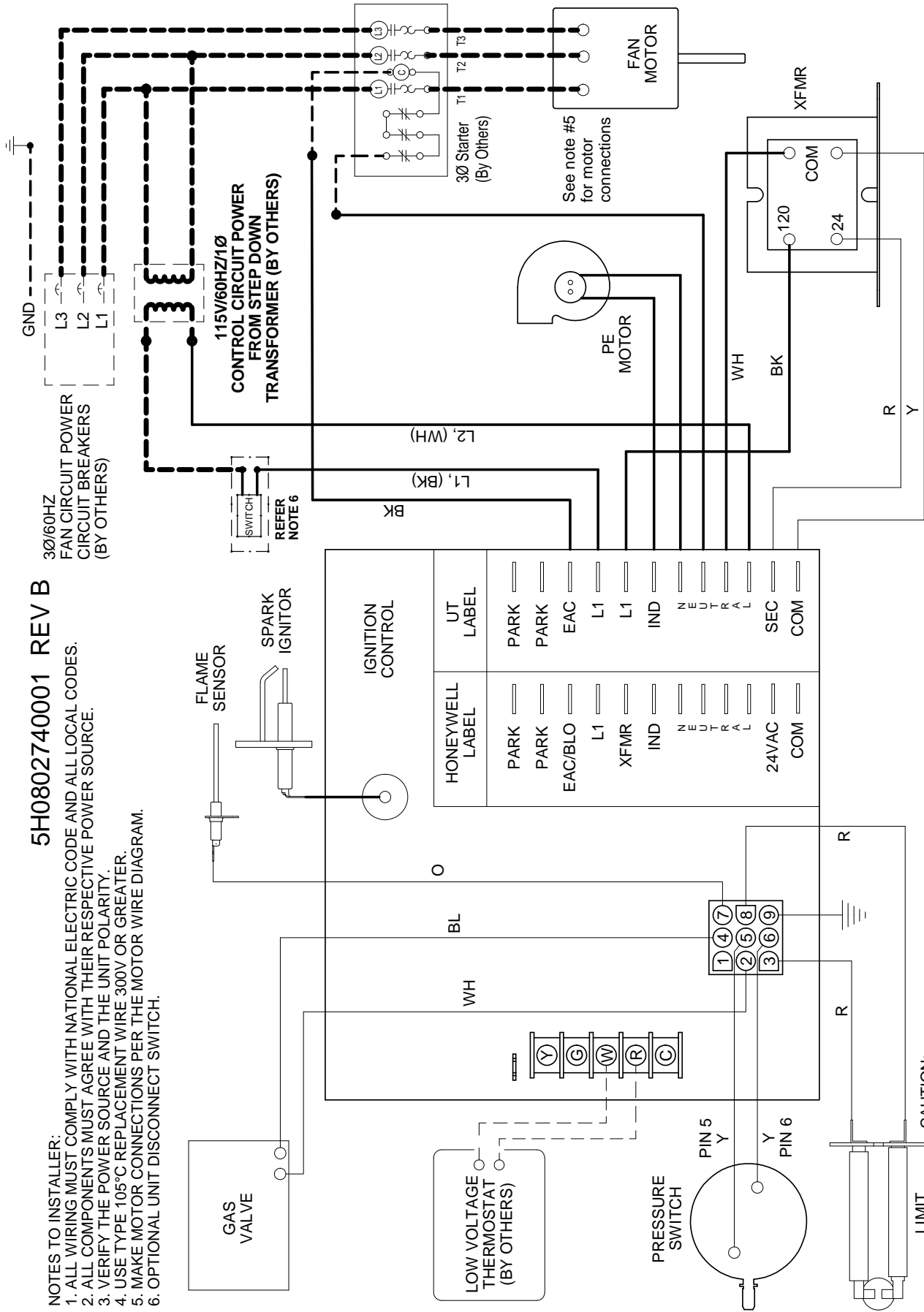

CAUTION:
FAILURE TO WIRE THIS UNIT ACCORDING TO THIS WIRING DIAGRAM MAY RESULT
IN INJURY TO THE INSTALLER OR USER. FOR DEVIATIONS CONTACT THE FACTORY.

WIRING DIAGRAMS – MODELS HD/HDB, HDS/HDC, PTP, PTS/BTS

5H0802740002 REV B

NOTES TO INSTALLER:

1. ALL WIRING MUST COMPLY WITH NATIONAL ELECTRIC CODE AND ALL LOCAL CODES.
2. ALL COMPONENTS MUST AGREE WITH THEIR RESPECTIVE POWER SOURCE.
3. VERIFY THE POWER SOURCE AND THE UNIT POLARITY.
4. USE TYPE 105°C REPLACEMENT WIRE 300V OR GREATER.
5. MAKE MOTOR CONNECTIONS PER THE MOTOR WIRE DIAGRAM.
6. OPTIONAL UNIT DISCONNECT SWITCH.

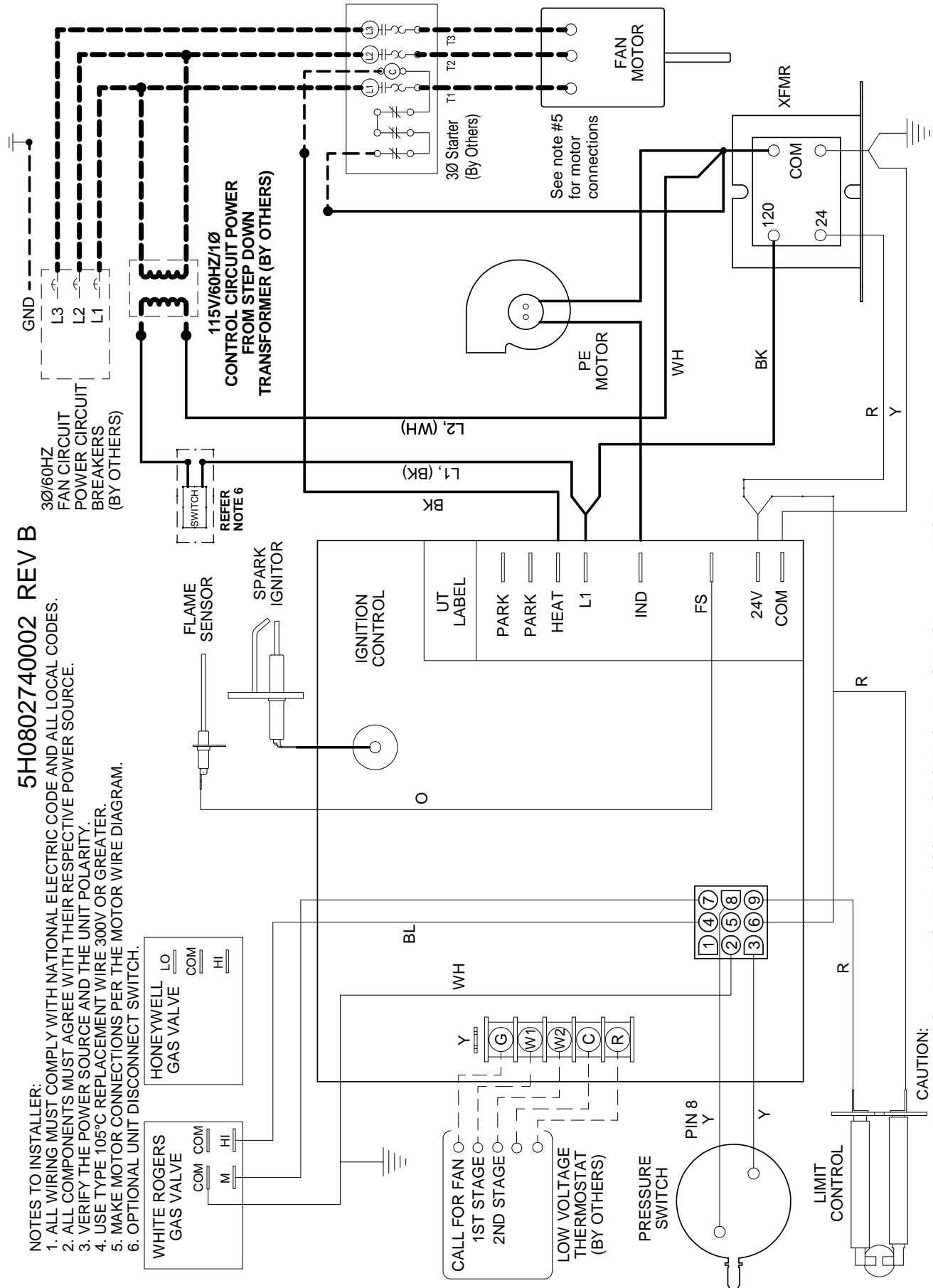

CAUTION:
FAILURE TO WIRE THIS UNIT ACCORDING TO THIS WIRING DIAGRAM MAY RESULT IN INJURY TO THE INSTALLER OR USER. FOR DEVIATIONS CONTACT THE FACTORY.

WIRING DIAGRAM - MODEL PTC

115V Unit Power

5H0807160001 REV K

- NOTES TO INSTALLER:
1. ALL WIRING MUST COMPLY WITH NATIONAL ELECTRIC CODE AND ALL LOCAL CODES.
 2. ALL COMPONENTS MUST AGREE WITH THEIR RESPECTIVE POWER SOURCE.
 3. VERIFY THE POWER SOURCE, AND THE UNIT POLARITY.
 4. USE TYPE 105°C REPLACEMENT WIRE 300V OR GREATER.
 5. FLAME ROLLOUT TO BE USED ON PTC UNITS 55/65/85/110 ONLY.

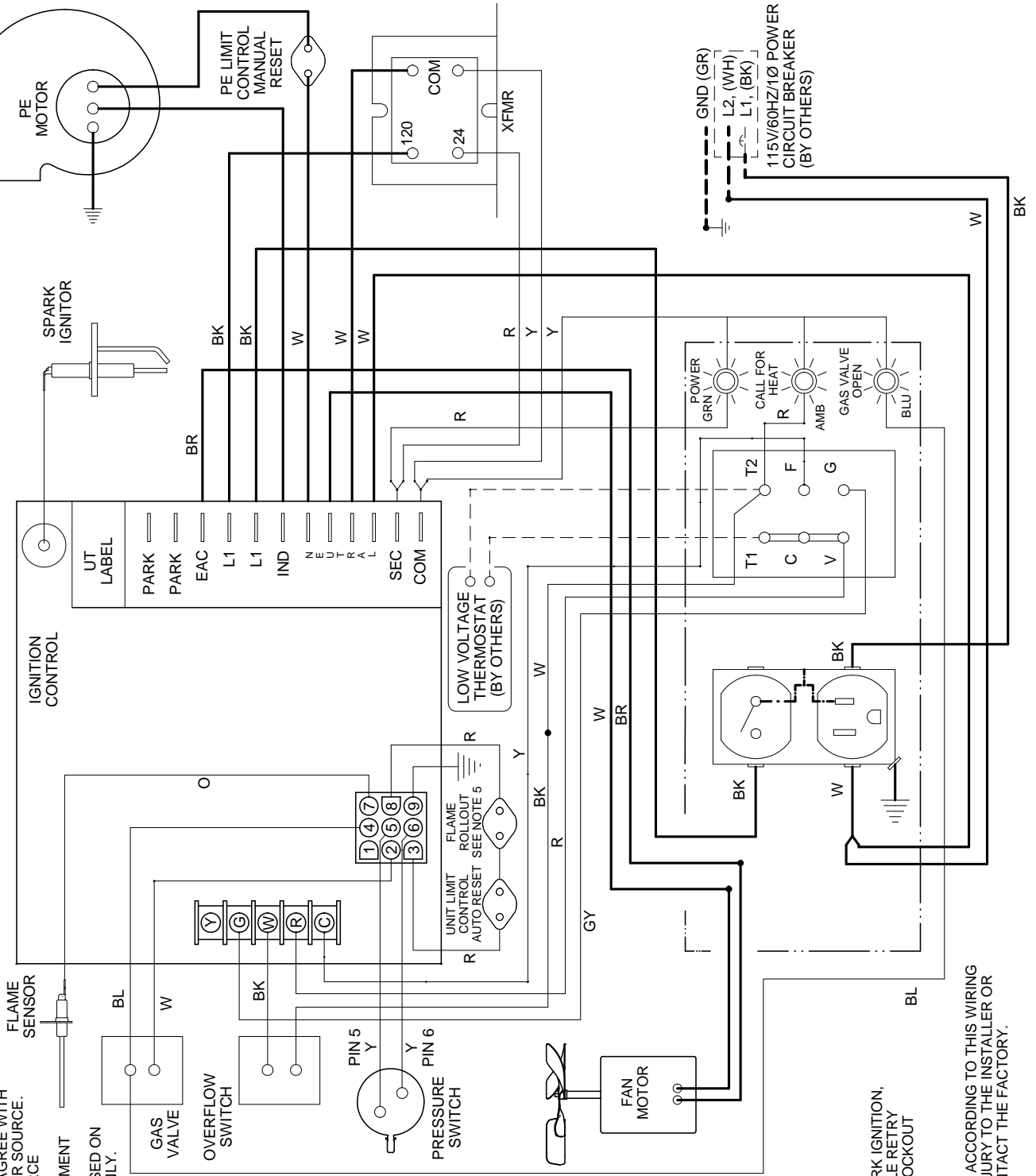

SINGLE STAGE, DIRECT SPARK IGNITION,
100% SHUT-OFF, MULTIPLE RETRY
W/ AUTO RESET FROM LOCKOUT

CAUTION:
FAILURE TO WIRE THIS UNIT ACCORDING TO THIS WIRING DIAGRAM MAY RESULT IN INJURY TO THE INSTALLER OR USER. FOR DEVIATIONS CONTACT THE FACTORY.

WIRING DIAGRAMS - MODEL PTC

115V Unit Power

5H0807160002 REV K

- NOTES TO INSTALLER:
1. ALL WIRING MUST COMPLY WITH NATIONAL ELECTRIC CODE AND ALL LOCAL CODES.
 2. ALL COMPONENTS MUST AGREE WITH THEIR RESPECTIVE POWER SOURCE.
 3. VERIFY THE POWER SOURCE AND THE UNIT POLARITY.
 4. USE TYPE 105°C REPLACEMENT WIRE 300V OR GREATER.

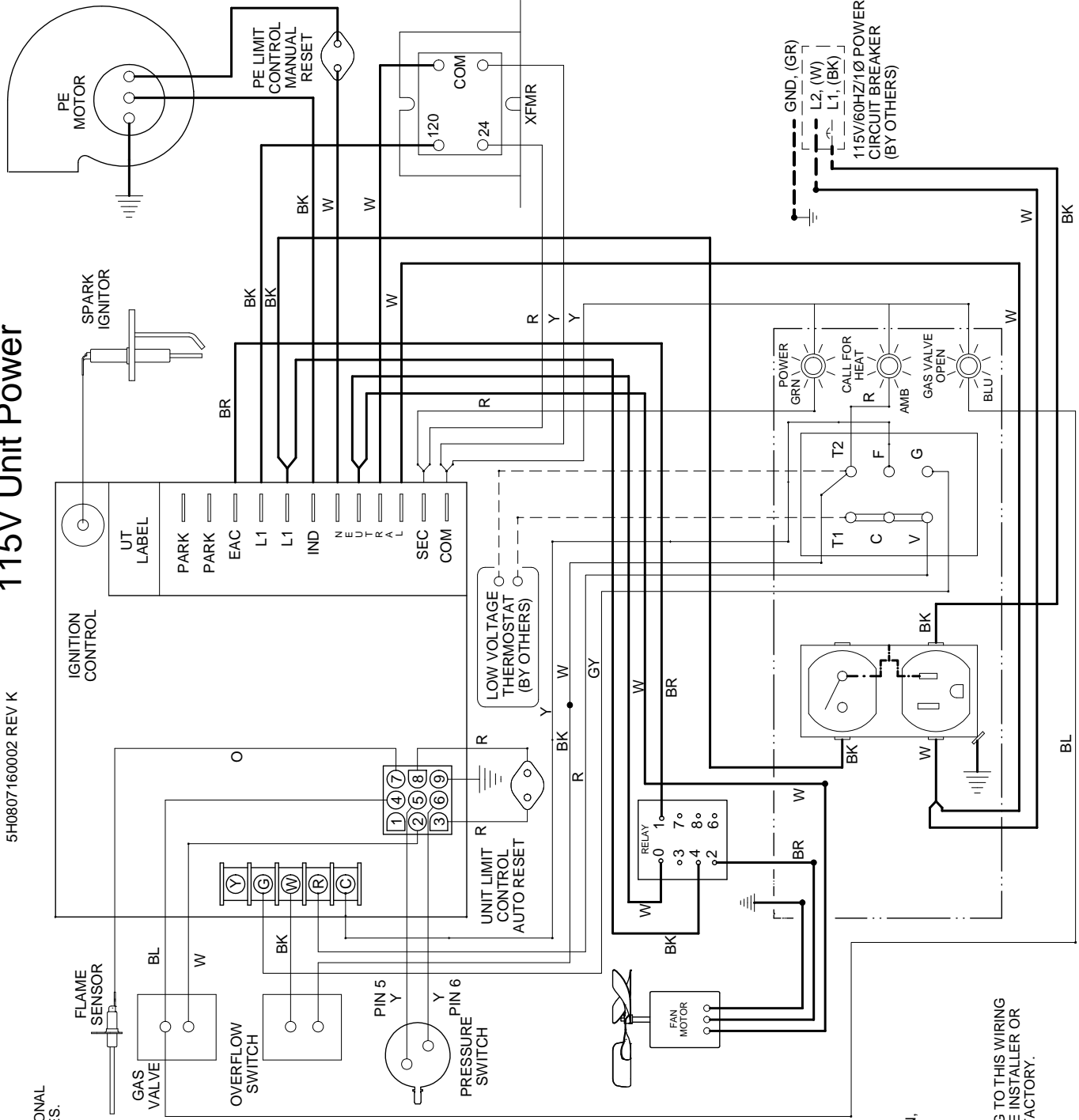

SINGLE STAGE, DIRECT SPARK IGNITION,
100% SHUT-OFF, MULTIPLE RETRY
W/ AUTO RESET FROM LOCKOUT

CAUTION:
FAILURE TO WIRE THIS UNIT ACCORDING TO THIS WIRING
DIAGRAM MAY RESULT IN INJURY TO THE INSTALLER OR
USER. FOR DEVIATIONS CONTACT THE FACTORY.

WIRING DIAGRAM – MODEL BTC

FACTORY - 115V Unit Power

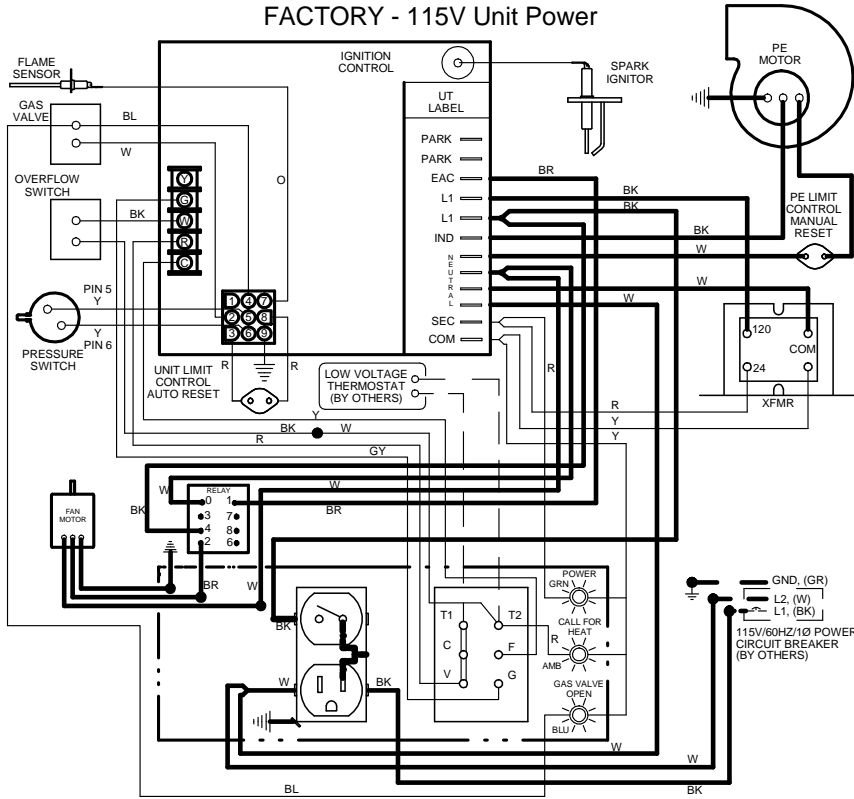

5H0807160003 REV K

CAUTION:
FAILURE TO WIRE THIS UNIT ACCORDING TO THIS WIRING
DIAGRAM MAY RESULT IN INJURY TO THE INSTALLER OR
USER. FOR DEVIATIONS CONTACT THE FACTORY.

SINGLE STAGE, DIRECT SPARK IGNITION,
100% SHUT-OFF, MULTIPLE RETRY
W/ AUTO RESET FROM LOCKOUT

FIELD - 230V Unit Power Conversion From 115V Base Unit

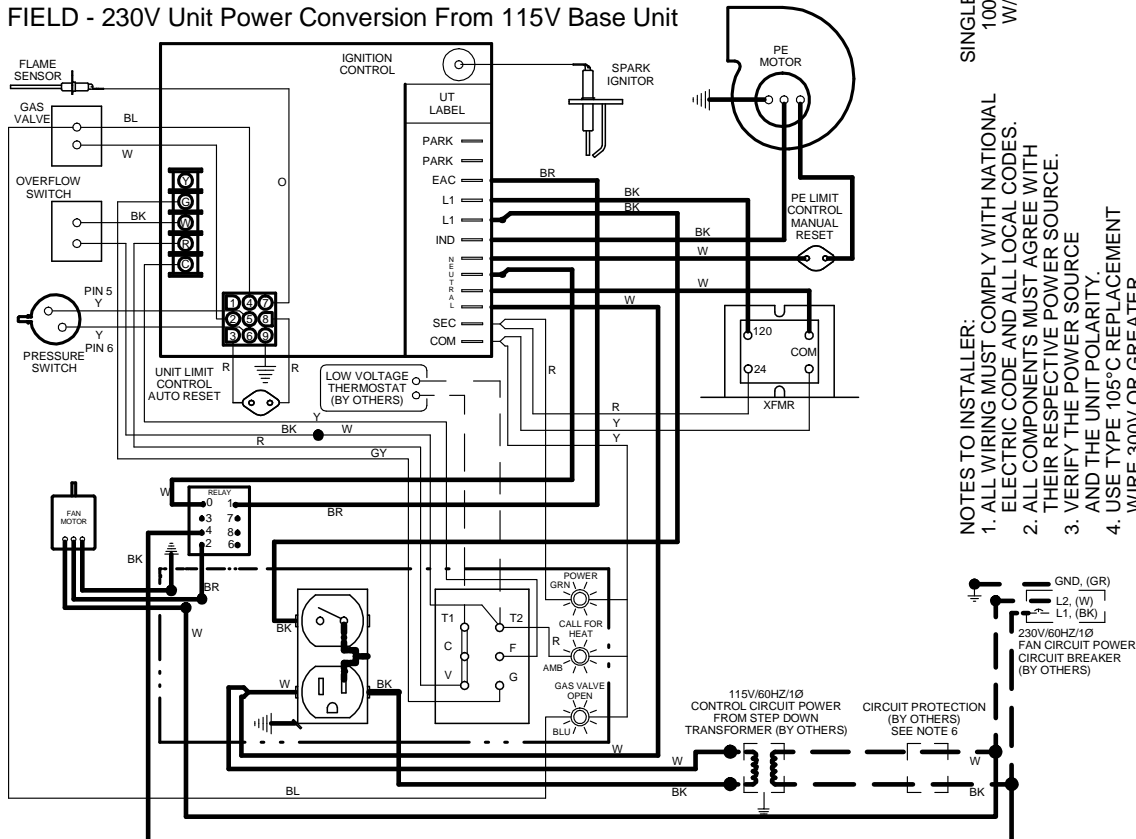

NOTES TO INSTALLER:
1. ALL WIRING MUST COMPLY WITH NATIONAL
ELECTRIC CODE AND ALL LOCAL CODES.
2. ALL COMPONENTS MUST AGREE WITH
THEIR RESPECTIVE POWER SOURCE.
3. VERIFY THE POWER SOURCE
AND THE UNIT POLARITY.
4. USE TYPE 105°C REPLACEMENT
WIRE 300V OR GREATER.

WIRING DIAGRAMS – MODEL BTC

CAUTION: FAILURE TO WIRE THIS UNIT ACCORDING TO THIS WIRING DIAGRAM MAY RESULT IN INJURY TO THE INSTALLER OR USER. FOR DEVIATIONS CONTACT THE FACTORY.

SINGLE STAGE, DIRECT SPARK IGNITION,
100% SHUT-OFF, MULTIPLE RETRY
W/ AUTO RESET FROM LOCKOUT

3Ø Unit Power

5H0807160004 REV K

- NOTES TO INSTALLER:
1. ALL WIRING MUST COMPLY WITH NATIONAL ELECTRIC CODE AND ALL LOCAL CODES.
 2. ALL COMPONENTS MUST AGREE WITH THEIR RESPECTIVE POWER SOURCE.
 3. VERIFY THE POWER SOURCE AND THE UNIT POLARITY.
 4. USE TYPE 105°C REPLACEMENT WIRE 300V OR GREATER.

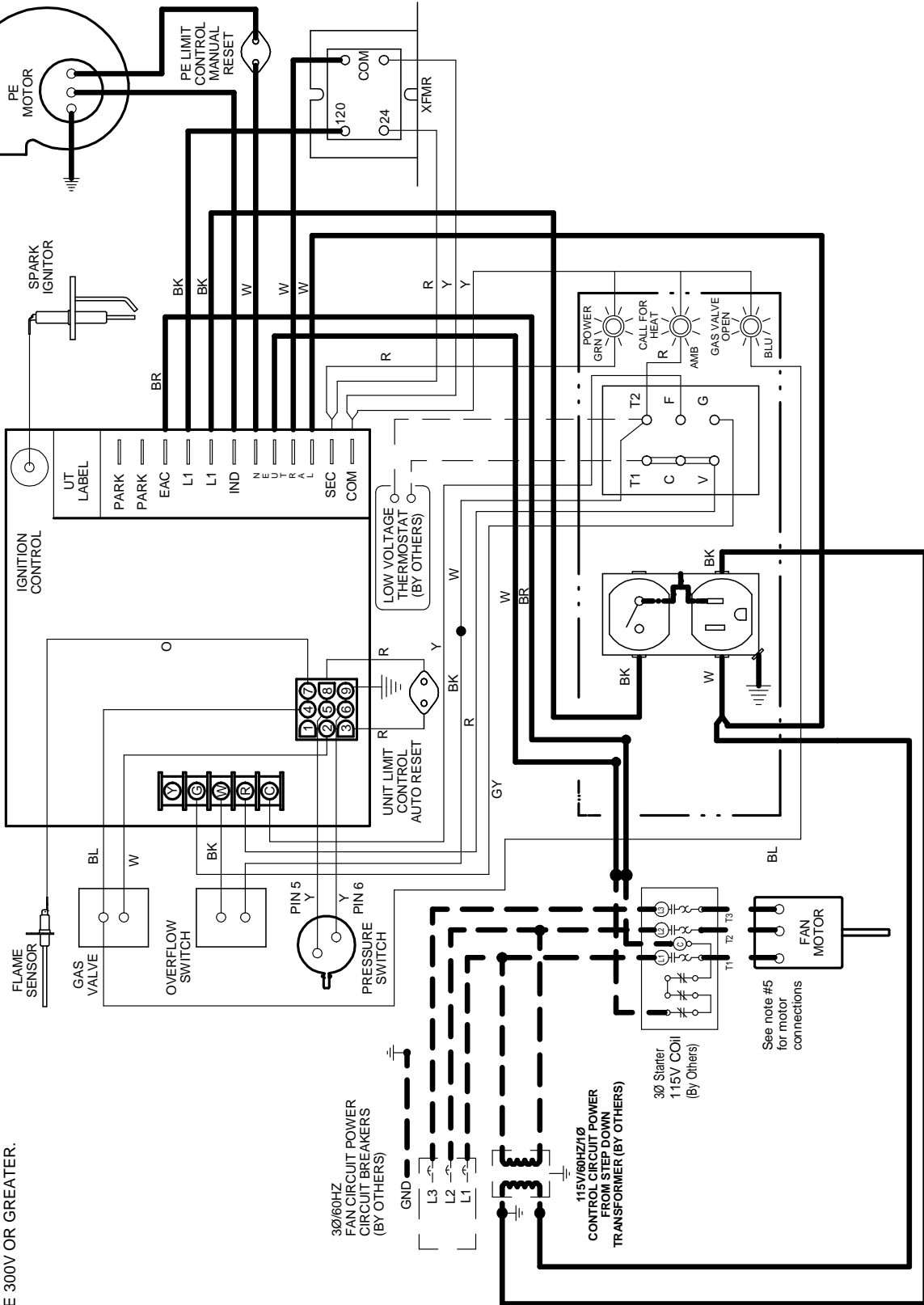

WIRING DIAGRAMS – THERMOSTAT & SUMMER/WINTER SWITCH

Single Stage Thermostat & Summer/Winter Switch Wiring

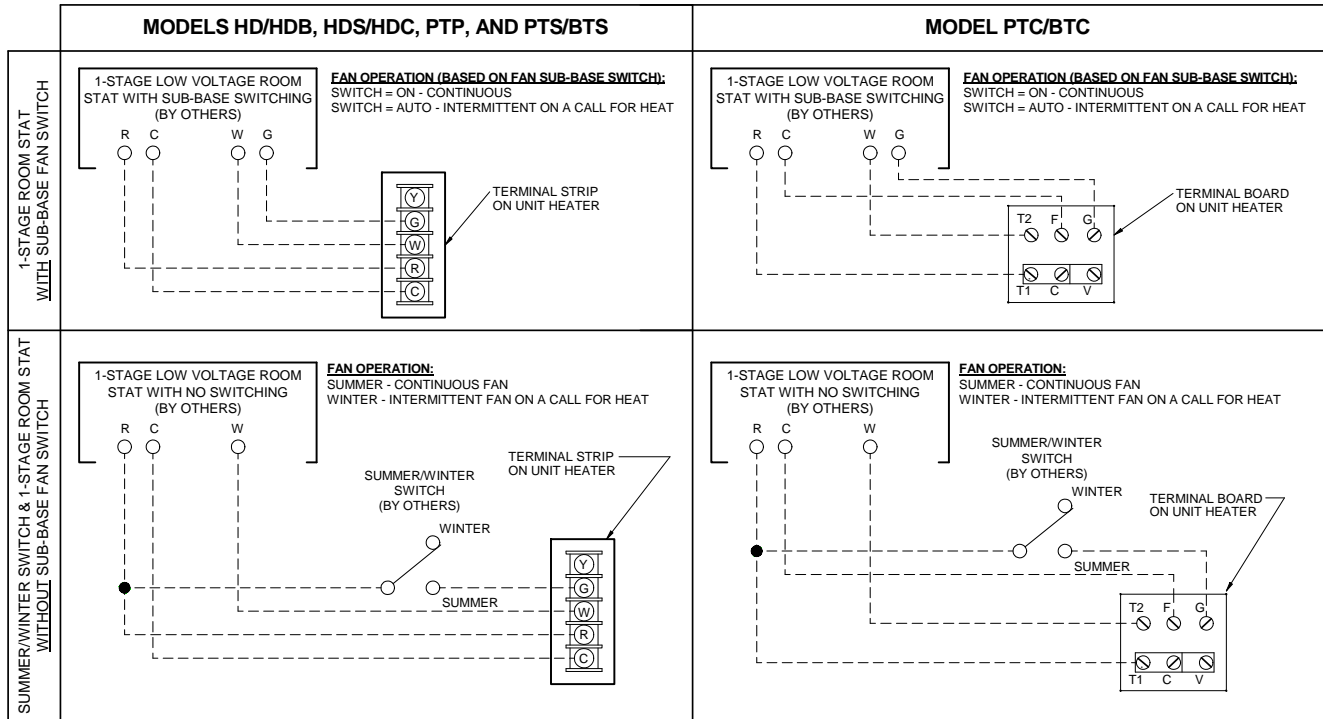

Two Stage Thermostat & Summer/Winter Switch Wiring

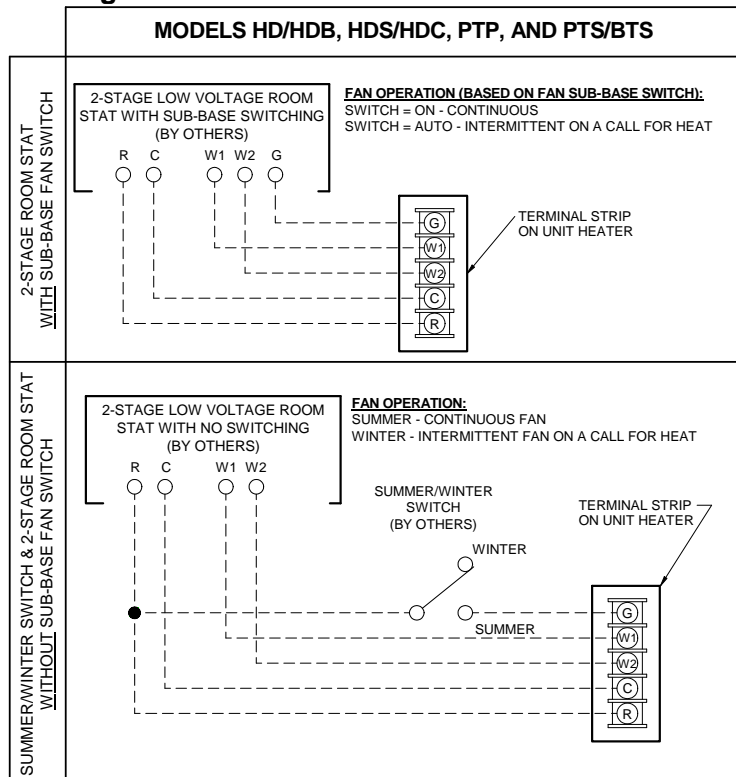

NOTE: GENERIC ROOM STAT TERMINALS SHOWN. ACTUAL STAT MAY USE DIFFERENT TERMINALS AND/OR WIRING. PLEASE CONSULT WIRING INSTRUCTIONS FOR STAT FOR PROPER WIRING.

Notes on Thermostat and Summer/Winter Switch Wiring:

Units are equipped as standard with a controller that activates the unit fan in either of the following ways:

- On a call for heat (thermostat closure between R & W terminals (W1 for 2-stage units) on the unit heater terminal strip (T1 & T2 on the external terminal board for model PTC/BTC units). The control automatically recognizes a call for heat as requiring fan operation.
- With switch closure between R & G terminals on the unit heater terminal strip (T1 & G on the external terminal board for model PTC/BTC units). The control recognizes this as an override to the fan control based on a call for heat and starts the fan.

The diagrams on this page are arranged as follows:

1. Single stage thermostat with a Fan On/Auto switch for fan control.
2. Single stage thermostat without a Fan On/Auto switch and a Summer/Winter switch for fan control.
3. Two stage thermostat with a Fan On/Auto switch for fan control.
4. Two stage thermostat without a Fan On/Auto switch and a Summer/Winter switch for fan control.

Note: A Summer/Winter switch used on these models does NOT require a control relay as was required on previous models.

WIRING DIAGRAMS -- ACCESSORIES

Wiring Multiple Single Stage Units to a Single Thermostat

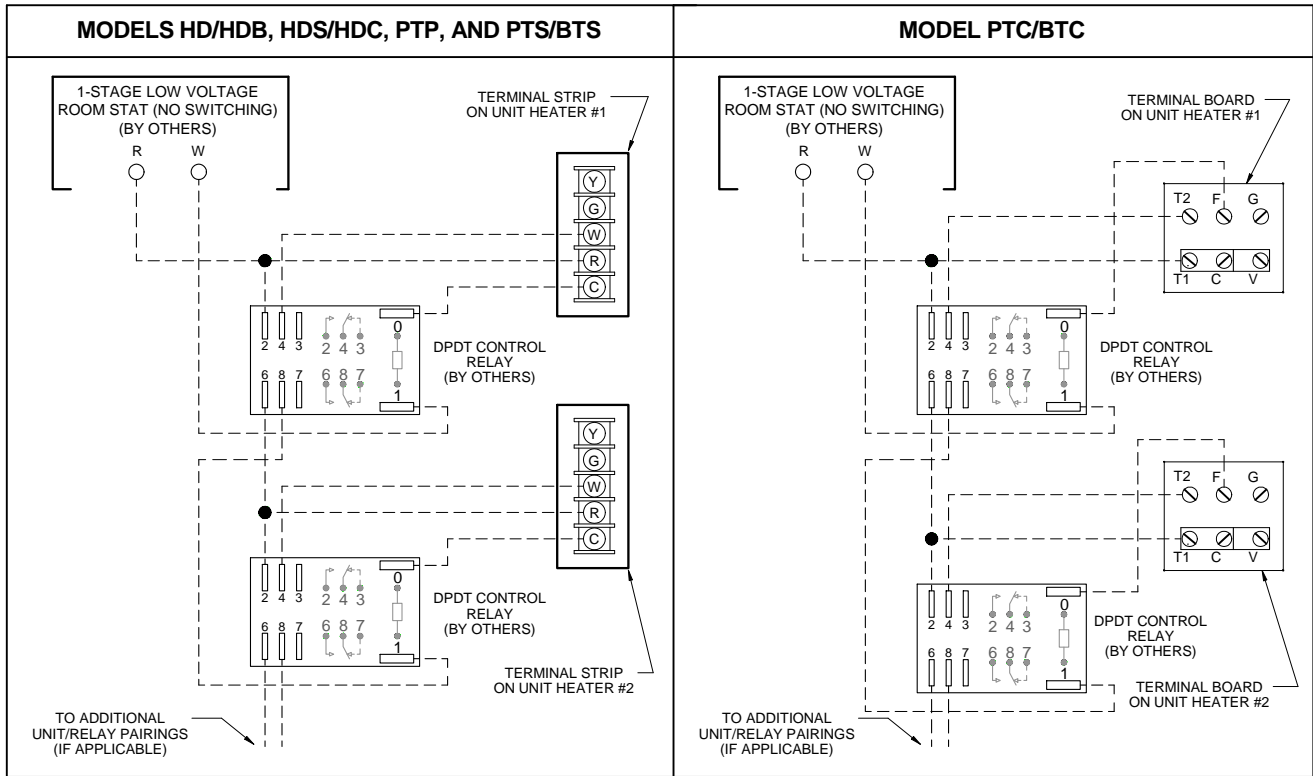

Notes on Wiring Multiple Single Stage Units to a Single Thermostat

When two or more unit heaters are controlled by one thermostat, it is necessary to electrically isolate each unit by using relays. If relays are not used, feedback in the low voltage circuits can occur. This feedback may cause operational problems, damage the electrical components in the low voltage circuit, or cause burnout of the low voltage transformers.

The figure above shows that the thermostat, powered from the terminal strip of unit heater #1 (UH-1), energizes the relay coil of the first relay (RE-1). When the RE-1 coil is energized, the first set of normally open (NO) contacts of that DPDT relay close and activate the gas controls of UH-1. The second set of normally open (NO) contacts on RE-1 are used to energize the relay coil of the second relay RE-2, powered through the terminal strip of UH-2. The first set of NO contacts on RE-2 close and activate the gas controls of UH-2. If a third unit is to be controlled from the same thermostat, a third relay RE-3 coil is wired to the second set of contacts on RE-2. This procedure is repeated for each additional unit which is to be controlled by the thermostat. Generally, there should be a quantity of DPDT relays that is one less than the quantity of heaters to be controlled.

Accessory Wiring for Model PTC/BTC Units

