



SOUTHWARK METAL MANUFACTURING COMPANY

Philadelphia, PA • Greenville, SC • Indianapolis, IN • Southaven, MS • Fremont, NE • Caldwell, ID

Corporate Headquarters: 2800 Red Lion Road, Philadelphia PA 19114

tel: (800) 523-1052 • fax (800) 722-2076 • www.southwarkmetal.com

SUBMITTAL DRAWING

**RETURN AIR PACKAGE
(MODEL NO: 811)**

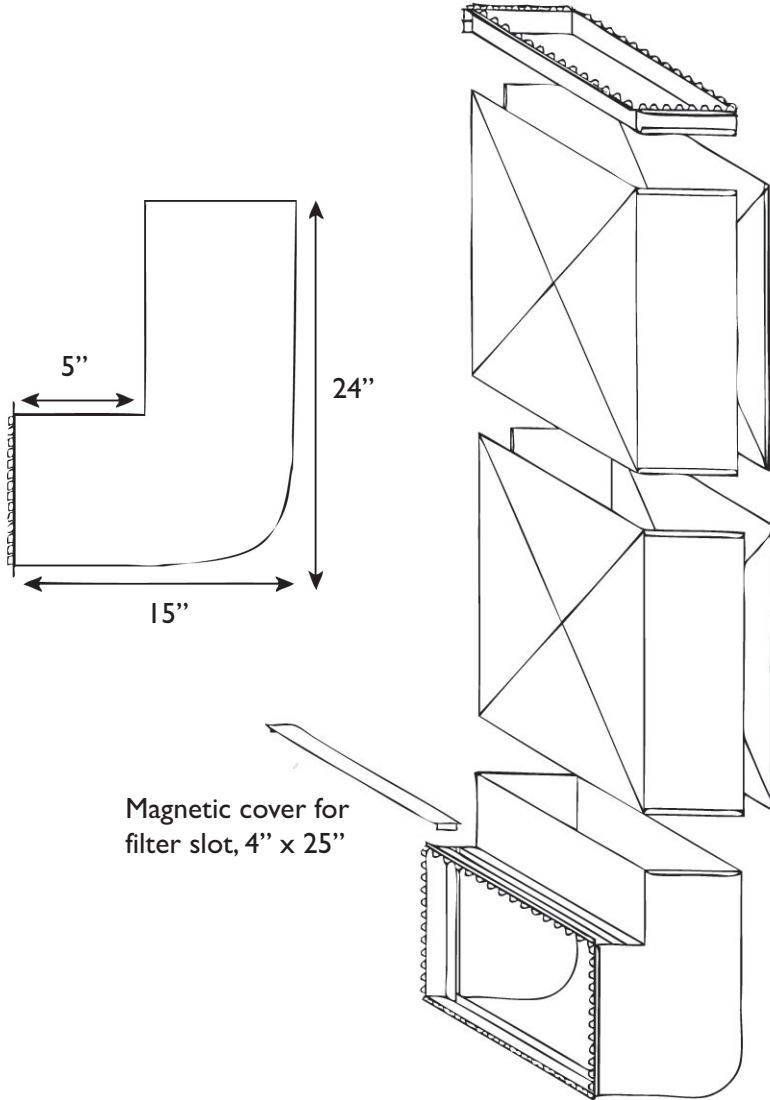

NOTES

- Material: Hot Dipped Galvanized Steel per ASTM A653 CS Type B
- Includes starting collar (#20), two 30" duct sections, one return air boot, and six 10" drive straps
- Ships knocked down in one carton
- S-cleats attached
- Starting collar height 2½" (81 IEC extended collar version 6½")
- 86" overall height when assembled (90" for #81 IEC)
- Duct dimensions 25x10; Return air opening 25x16
- Uses 16x25 1" filters

JOB NAME: _____
 LOCATION: _____
 ARCHITECT: _____
 ENGINEER: _____
 CONTRACTOR: _____

DATE: 10/17/14

SW-811NE

SD-0223

Return Air Package
 MODEL NO: 811