

MODEL ANPD100H-3

Ultra Silent, High Performance, Attractive Design Grille

Description

- Very quiet two speeds EC motor fan for ceiling or wall mounted hold.
- Low speed runs continuously (Adjustable 0, 30CFM - Max CFM).
- ETL evaluated and confirm to UL and cUL safety standards.
- HVI and ENERGY STAR certified.

Housing

- Made of rugged 26 GA galvanized steel
- Detachable 4 inch polymeric collar which includes a light weight built in back draft damper.
- Housing size: 9"x9"x5 3/4"

Motor/Blower

- Total enclosed brushless EC motor designed to operate continuously.
- Power rating should be 120 volts and 60 Hz
- Comes with a built in overload disconnect for safety and longer motor life.

Grille

- The grille is low profile that has elegance and still able to maintain its simplicity.
- Grille dimension: 11-13/16"x11-7/16".

Typical specification

- Ceiling ventilator shall have corrosion resistance galvanized steel.
- Continuous adjustable low speed operation allows accurate CFM selection.
- Built in toggle switch for high speeds (50-80-100CFM) selection.
- Blower assembly shall be removable, have a centrifugal type blower wheel and a permanently lubricated motor designed for continuous operation.
- Includes an attachable non metallic collar with build in back draft damper.
- Air and sound delivery shall meet the ENERGY STAR, HVI certified ratings as per the fan curves attached.



Optional
LED Light grille

Reference	QTY.	Remarks	Project:
			Location:
			Architect:
			Engineer:
			Contractor:
			Submitted by:
			Date:

CERTIFICATIONS



MODEL ANPD100H-3

Model Number	ANPD100H-3					
Static Pressure in inches w.g.	0.1	0.25	0.1	0.25	0.1	0.25
Air Volume (CFM)	50		80		100	
Noise (sones)	<0.3	N/A	0.5	N/A	1.0	N/A
Fan Watts (W)	9.7					
Duct Diameter	4"					
Power Rating (V/Hz)	120/60					

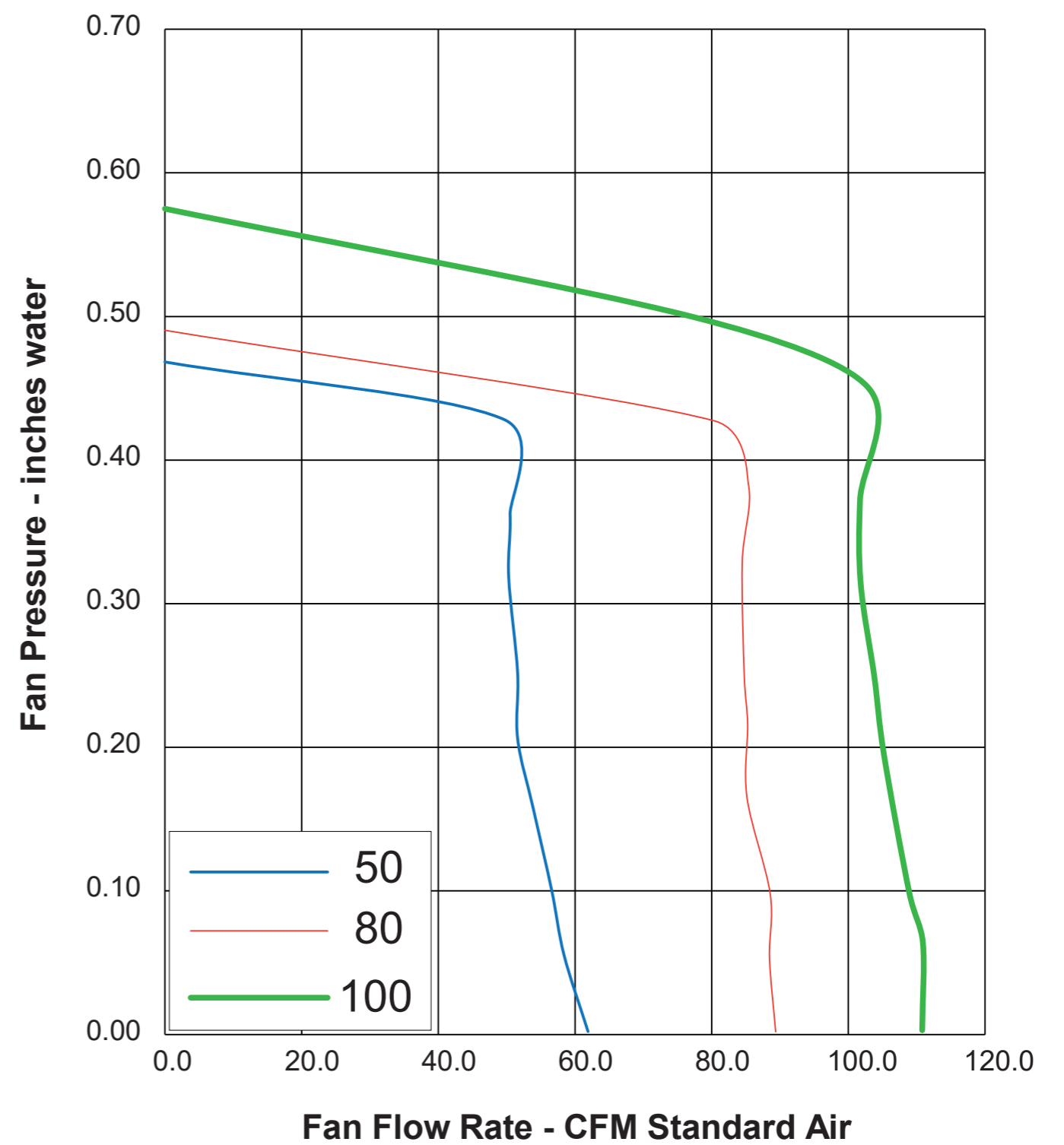
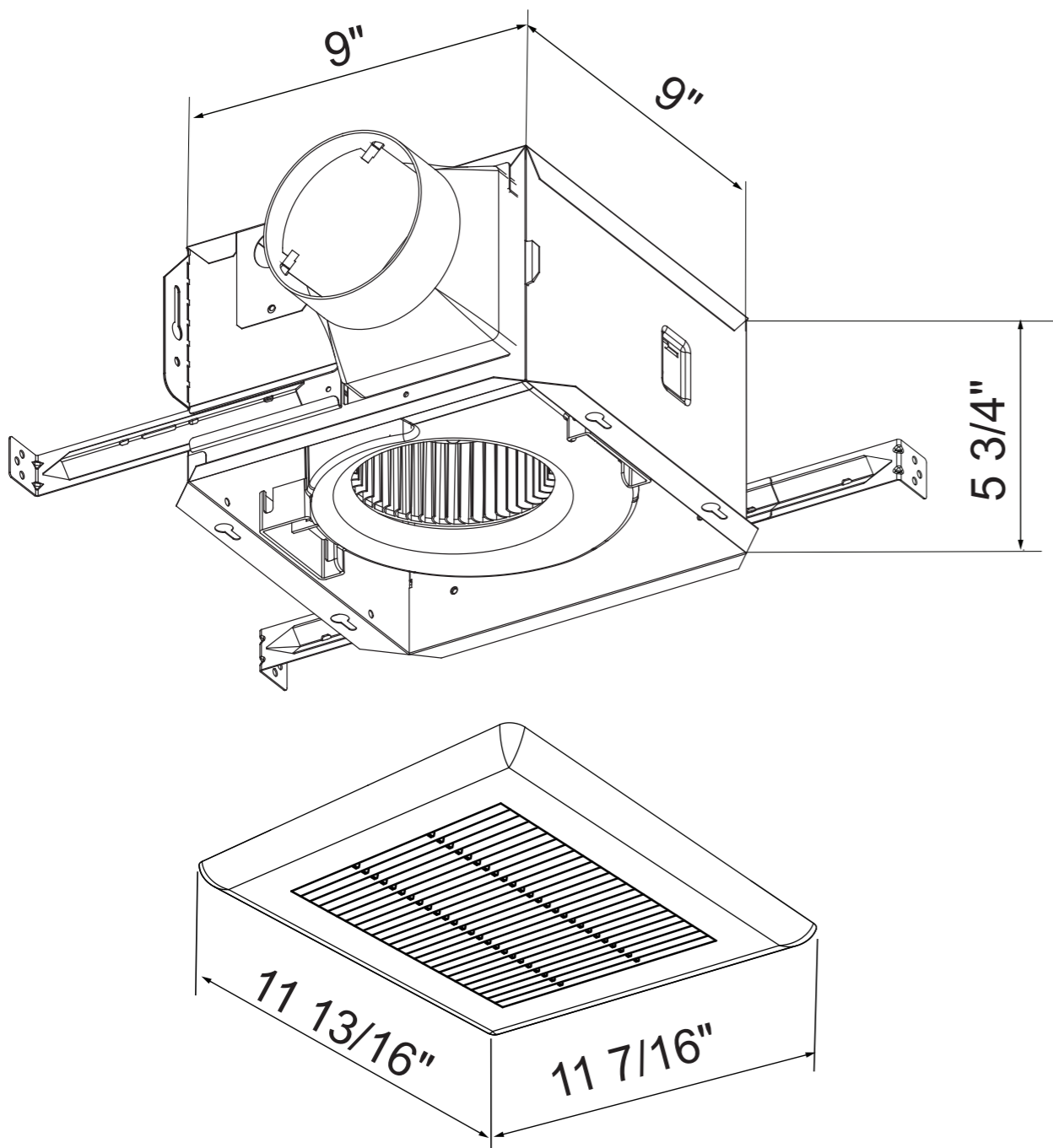

CERTIFICATIONS

