

# ACIQ<sup>®</sup>



# TSK Inline Fan

For United States and Canada

### Main features with TSK Series

- All Mold design construction. Corrosion resistant and baked powder coatings.
- The impeller is backward, centrifugal efficiency axial outlet.
- The fan is compact, so it is easy to installation and repair.
- It is designed for direct connection in line with standard diameter circular ducting.
- Single-phase asynchronous external rotor motor applied; Low noise.
- It is used to ventilate in factory and the building.

### Typical application includes:

Every TSK Fan Has Been Test For Three Different Planes Before Package

- Stairwell Pressurization
- Low noise Industry
- Hydroponic Grow Farm
- Agricultural area

### TSK Series Construction Features

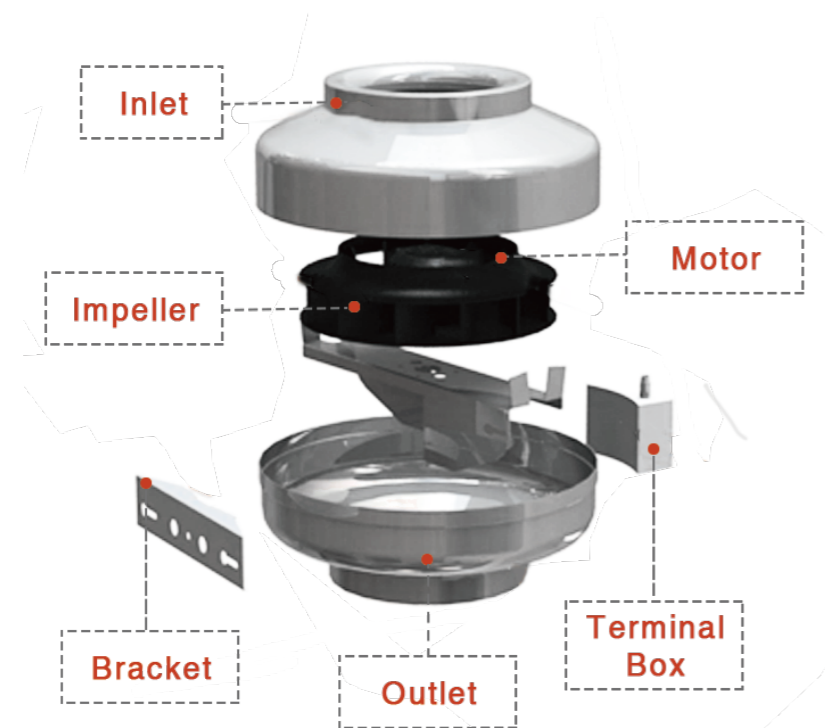

### TSK100 (4") Dimension and Performance

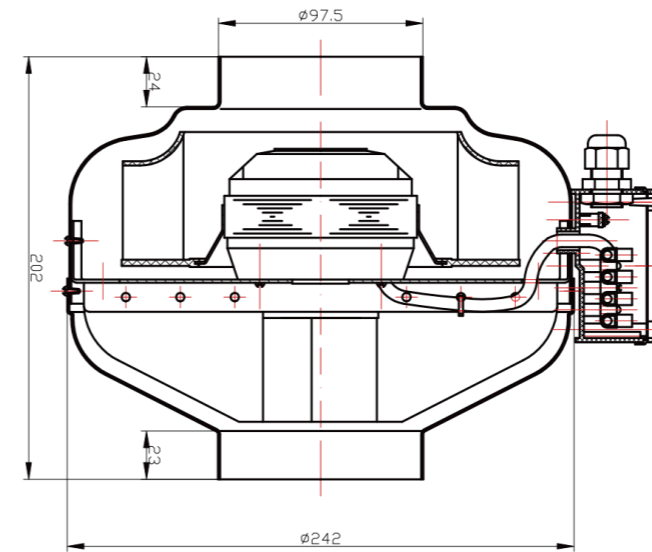

TSK100 (4")	100 (4")
Voltage	AC Technology 110-120v/60Hz
Working Power	98W
Speed	2500RPM
Noise	72dB 60dB (3M)
Working temp	60°C
Maximum Flow Value	171CFM

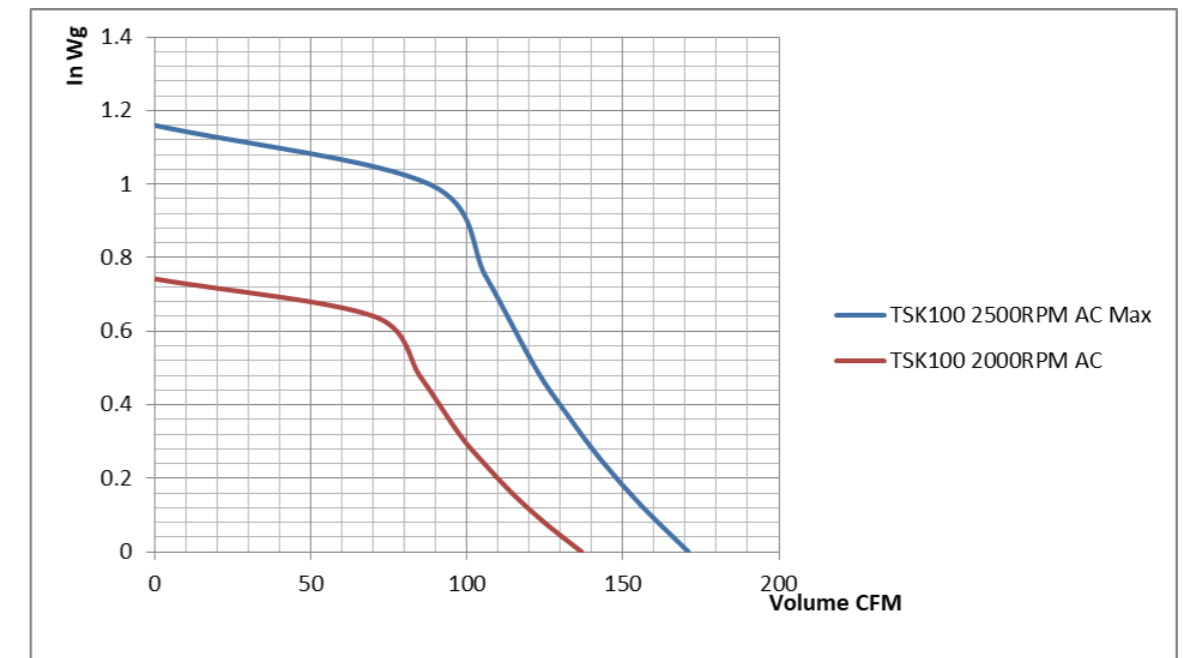

TSK150 (6'') Dimension and Performance

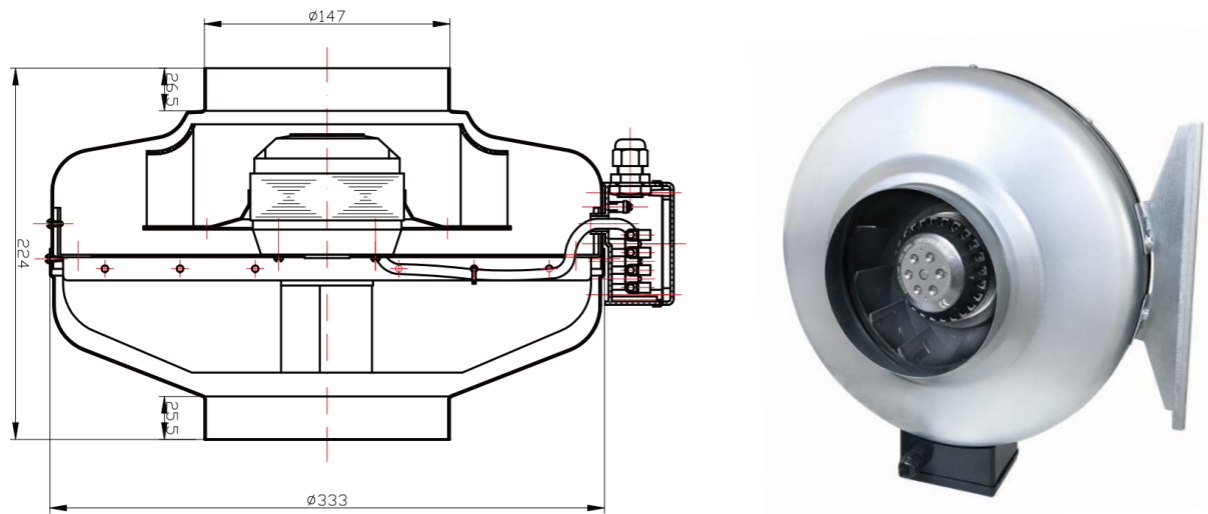

TSK150 (6'')	150 (6'')
Voltage	AC Technology 110-120v/60Hz
Working Power	130W
Speed	2500RPM
Noise	72dB (1M) 60dB (3M)
Working temp	60 C
Maximum Flow Value	435CFM

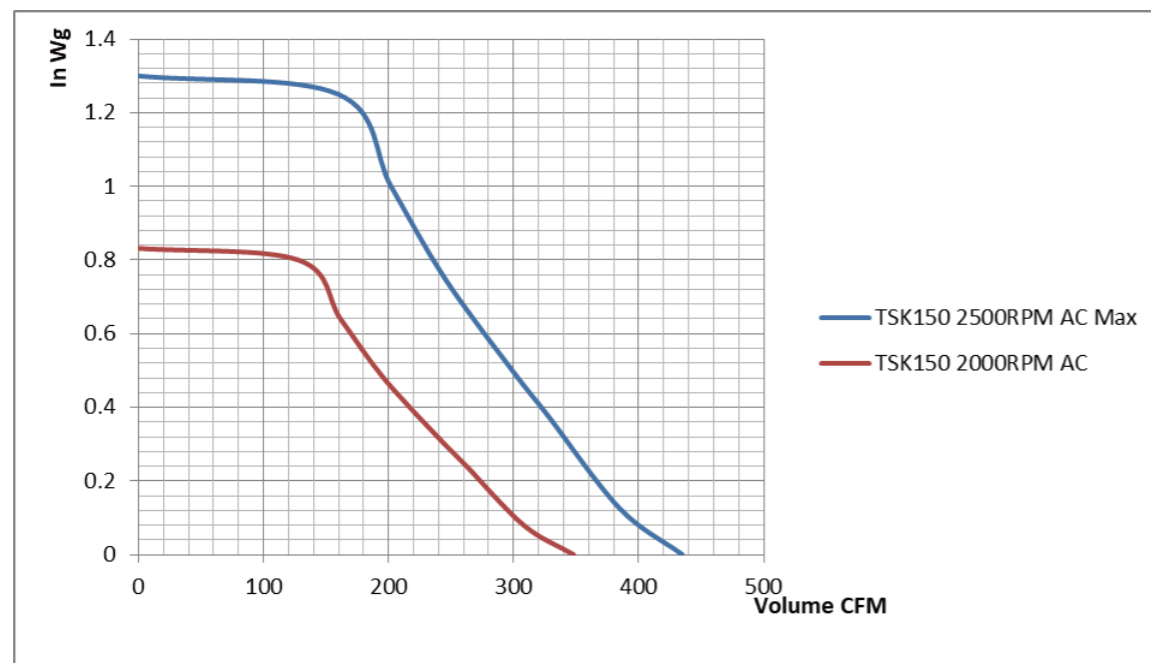

TSK200 (8'') Dimension and Performance

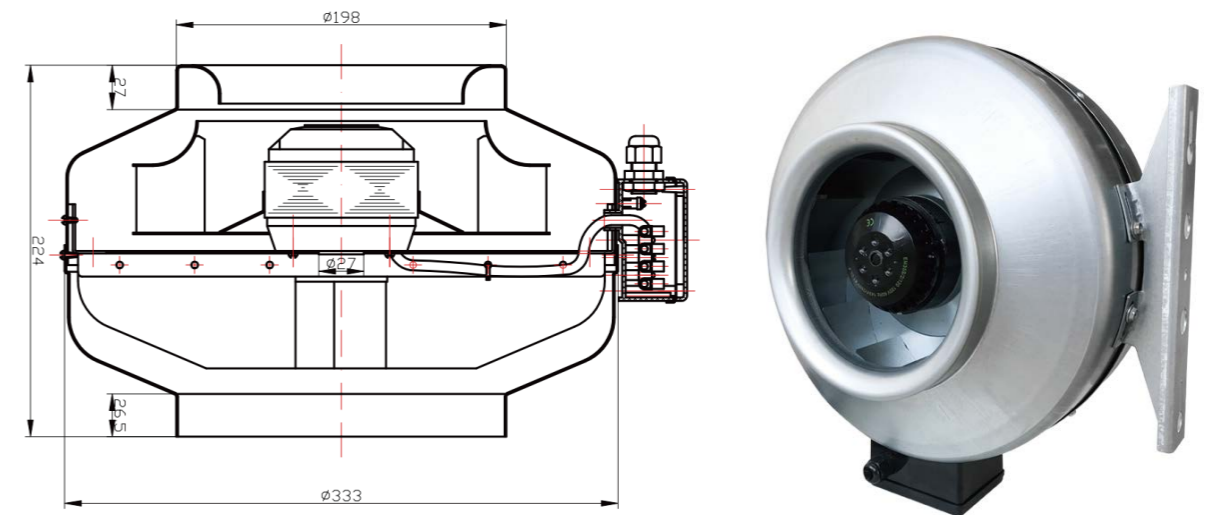

TSK200 (8'')	200 (8'')
Voltage	AC Technology 110-120v/60Hz
Working Power	210W
Speed	2500RPM
Noise	76dB (1M) 64dB (3M)
Working temp	60 C
Maximum Flow Value	598CFM

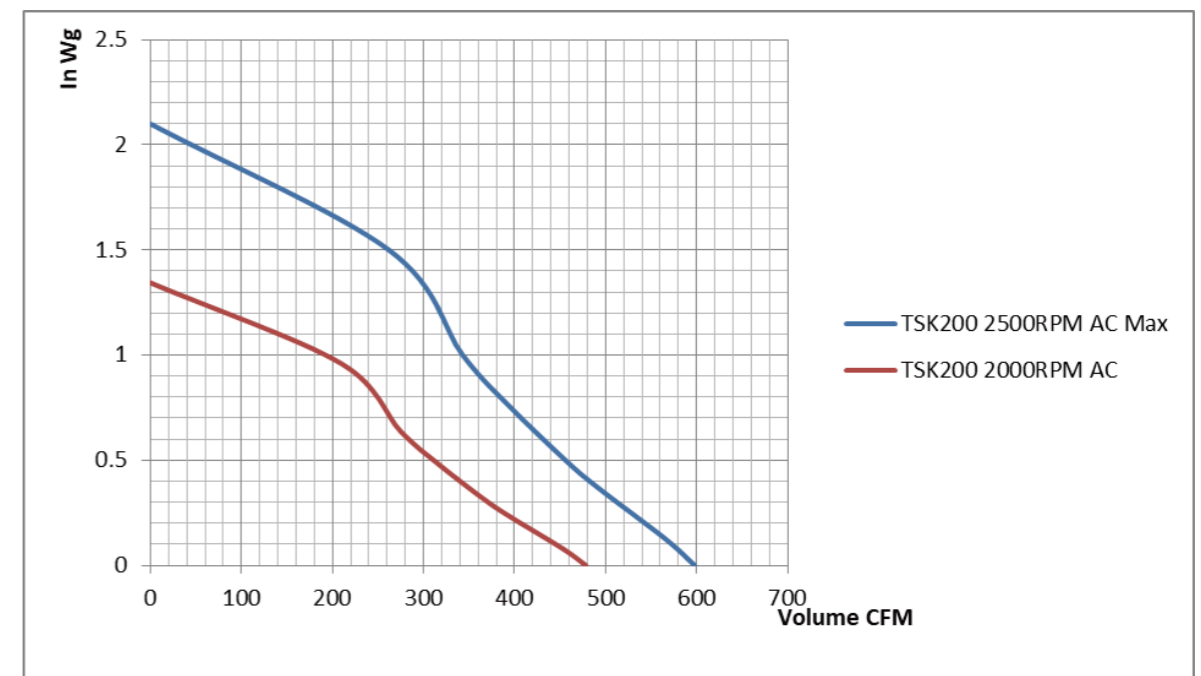

TSK250 (10'') Dimension and Performance

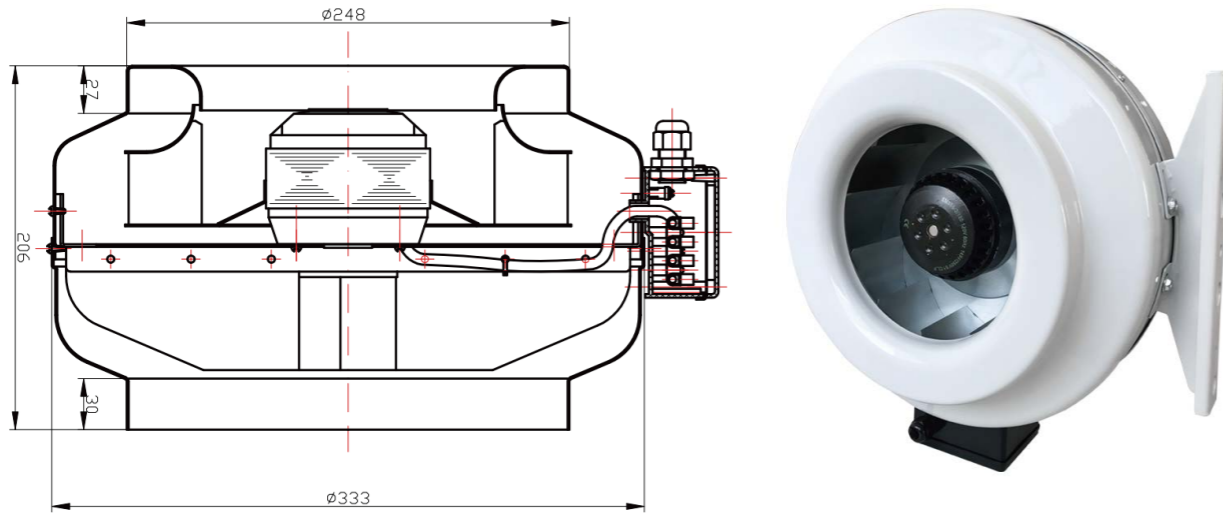

TSK250 (10'')	250 (10'')
Voltage	AC Technology 110-120v/60Hz
Working Power	230W
Speed	2500RPM
Noise	77dB (1M) 65dB (3M)
Working temp	60°C
Maximum Flow Value	618CFM

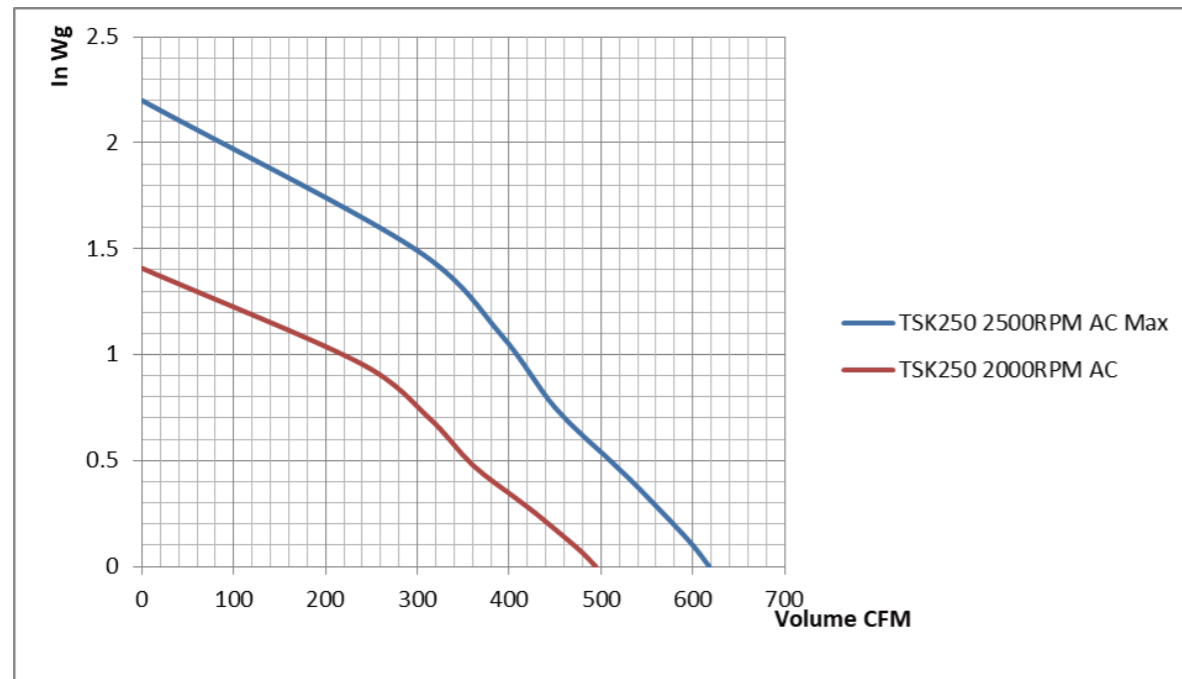

TSK300 (12'') Dimension and Performance

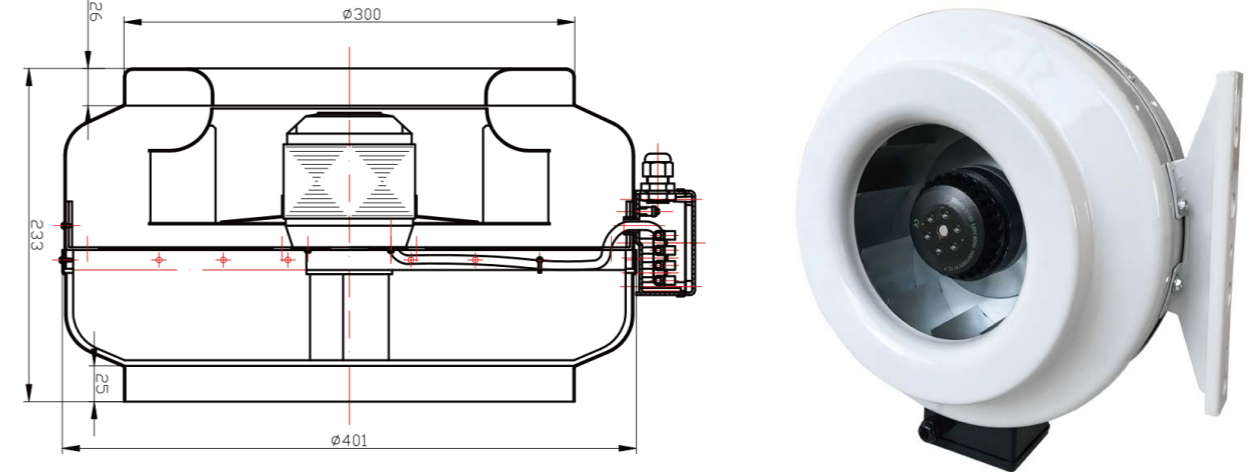

TSK300 (12'')	300 (12'')
Voltage	AC Technology 110-120v/60Hz
Working Power	295W
Speed	2500RPM
Noise	76dB (1M) 64dB(3M)
Working temp	60°C
Maximum Flow Value	942CFM

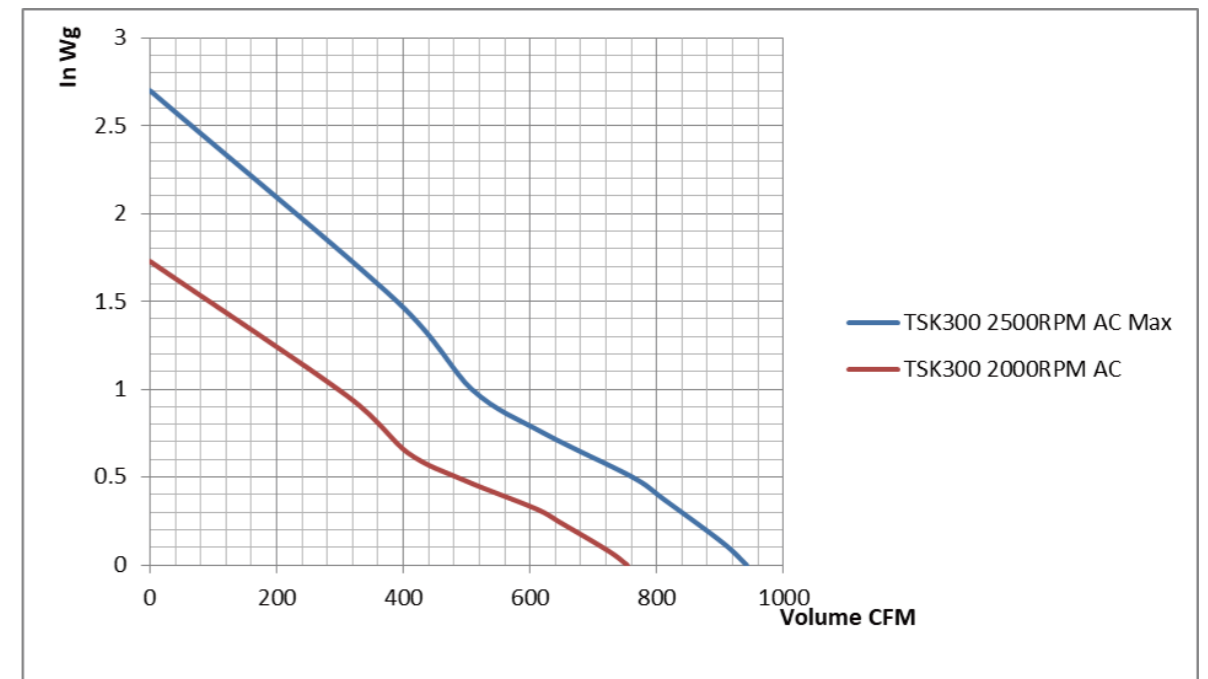

## Usage Description

1. The Fan Is Mainly Use In Delivering The Clean Air Without The Place That With Easy Burning Materials, Explosive Materials And Powder
2. If The Fan Is Fed With External Rotor Machine And Sealed Ball Bearing. It Is Free Maintenance.
3. If The Fan Install In The Damping And Sobering Area, Continuous Operation Is Required For The Fan.
4. The Fan Can Be Installed In The Outdoor Or Damp Environment With Drainage System.
5. All The Fans Are Feeding With International Standard Motors, Which Are Single Phase 120v, 60hz Or 220v, 50hz And Three Phases 380v, 50hz
6. Installation Is Available In Any Areas

## Installation

1. Must Be Install According To The Air Flow Marking
2. Must Be Connect To The Piping Or Equip With Safety Accessories
3. Must Be Installing In A Proper Way And Make Sure The Outlet Is Without Any Unusual Materials.
4. Try To Installing The Fan As Easy As For The Maintenance Purpose
5. Fan Required Flanges In Order To Avoid The Piping Damage When Vibrated
6. Speed Controller Or Transformer Is Available To Connect To The Fan
7. Wiring Diagram Is In The Package.
8. Wiring Must Be Strictly Following The Wiring Diagram.
9. Electrical Installation Must Be Done By Professional Technicians.
10. Electrical Installation Must Be Connecting In The Special Control Box.

## Operation

Before Operation, Please Make Sure

1. The Real Maximum Current Cannot Be Exceed The National Standard Index:+5%.
2. The Voltage Pulsation Is Between +6% --+10%
3. No Exceptional Noise Produce When Operation.
4. The Rotating Direction For Three Phase Motor Is The Same As The Marking.

## Maintenance

1. Before Repair Or Maintenance The Fan, Please Make Sure The Fan Is Stop And The Fan Is Not Working In Overload Condition
2. When Disassemble The Larger Fan, Please Care For The Weight To Avoid Blocking And Scratching
3. Cleaning The Fan Once A Year, So That It Can Keep The Function And Avoid The Unnecessary Damage.
4. Ball Bearing Is Free Maintenance Except For The Necessary Updates.
5. When Cleaning The Fan, Please Do Not Use The High Pressure Washer Or Strong Solvent, And Do Not Take Out The Damaging Impeller
6. Make Sure The Fan Is Operating Without Any Noise

## Failure Detection

1. Make Sure The Fan Is In The Load Condition.
2. Verify The Impeller Is Without Block.
3. Please Do Check With The Heat-variable Switch And Motor Protector. If The Switch Is Not In Connected, Please Do Check It. If Its Need To Restart Makes Sure The Power Supply Is Cut Off In A Few Minutes Until The Rated Current Is Not Higher Than 1.6a. If The Motor Has The Heat Protector, It Will Automatically Reset After Cool Down.
4. Make Sure The Capacitor Is Connected According To The Wiring Diagram.
5. Please Change The Capacitor At The First Time When The Fan Is Not Work.
6. Please Contact The Distributor If The Fan Is Still Not Work
7. When Send Back The Fan To The Distributor, Please Clean It And Make Sure The Cables Are

## Guarantee

The Guarantee Is Valid Only With The Guideline Of This Manual.

Noise Level Test Method

1m/45° Free Zone, Without Connect The Ducting Noise Data

