

ACiQ

THERMOSTAT

INSTALLATION & OWNER'S MANUAL

Model: STN731RF

WARNING: DO NOT destroy or lose this manual. Please read the manual thoroughly before installing or operating the controller. Also, store the manual in a place that allows for easy retrieval and future reference. The actual shape and size of your product may vary.

VERSION DATE: 03-02-26

THEMOSTAT QUICK REFERENCE

Thermostat Applications Guide

Description	
Gas or Oil Heat	Yes
Electric Furnace	Yes
Heat Pump (No Aux. or Emergency Heat)	Yes
Heat Pump (With Aux. or Emergency Heat)	Yes
Multi-Stage Systems	No
Heat Only Systems	Yes
Heat Only Systems - Floor or Wall Furnace	Yes
Cool Only Systems	Yes
Millivolt Conventional Systems	No
Two Transformer Systems	No

Table of Contents

Page

Thermostat Quick Reference	2-3
Installation Tips	4-9
Wiring Dia grams	10-14
Technician Setup	15-18
Thermostat paired	19
Specifications	20

Power Type

Battery Power

Hardwire (Common Wire)

IMPORTANT SAFETY INFORMATION WARNING:

- Always turn off power at the main power source by unscrewing fuse or switching circuit breaker to the off position before installing, removing, cleaning, or servicing thermostat.
- Read all of the information in this manual before installing or programming this thermostat.
- This is a 24V AC low voltage thermostat. Do not install on voltages higher than 30V AC.
- All wiring must conform to local and national building and electrical codes and ordinances.
- Do not short (jumper) across terminals on the gas valve or at the system control to test installation. This will damage the thermostat and void the warranty.

Getting to know your thermostat

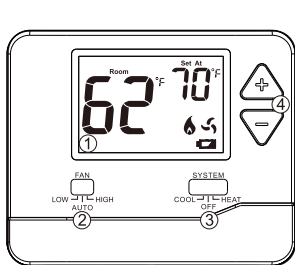

Indicates the current room temperature

Displays the user selectable setpoint temperature

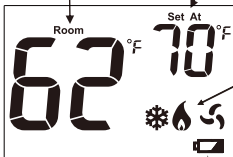

System operation indicators:
The COOL, HEAT or FAN icon will display when the COOL, HEAT or FAN is on.
NOTE: The compressor delay feature is active if these icons are flashing. The compressor will not turn on until the 5 minute delay has elapsed.

- ① LCD
- ② Fan Switch
- ③ System Switch
- ④ Setpoint Buttons



Caution:

When the battery icon  appears replace your 2x AAA batteries immediately. Failure to do so may result in your heating & cooling system becoming inoperable. Freezing or overheating can occur.

INSTALLATION TIPS

Wall Locations

The thermostat should be installed approximately 4 to 5 feet above the floor. Select an area with average temperature and good air circulation.

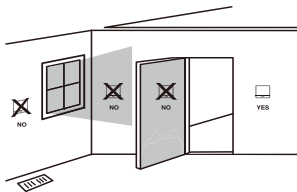

Installation Tip

Pick an installation location that is easy for the user to access. The temperature of the location should be representative of the building.

Do not install thermostat in locations:

- Close to hot or cold air ducts
- That are in direct sunlight
- With an outside wall behind the thermostat
- In areas that do not require conditioning
- Where there are dead spots or drafts (in corners or behind doors)
- Where there might be concealed chimneys or pipes

1 Turn Off the Power of Your Heating/Cooling System

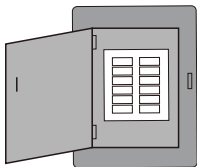

Circuit breaker
box

or



Heating/cooling system
power switch



Caution: Electrical Hazard

Failure to disconnect the power before beginning to install this product can cause electrical shock or equipment damage.



Warning:

All components of the control system and the thermostat installation must conform to Class II circuits per the NEC Code.

INSTALLATION TIPS

2 Remove Old Thermostat -(If Any)

Remove the old thermostat, Remove the old thermostat, Remember the function of the cable or port before disconnecting, and then remove the wall panel

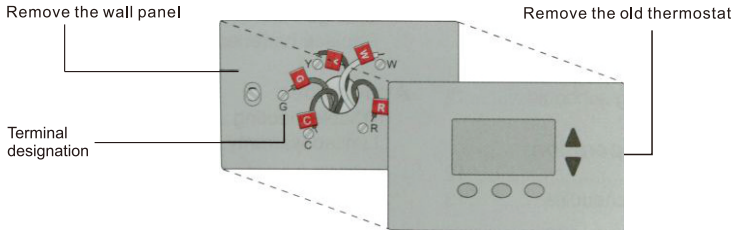

3 Mount New Wallplate

Mount the new wallplate using the included screws and anchors.



Mercury Notice:

All of our products are mercury free. However, if the product you are replacing contains mercury, dispose of it properly. Your local waste management authority can give you instructions on recycling and proper disposal.

For vertical mount put one screw top and one screw bottom.

For horizontal mount put one screw left and one screw right.

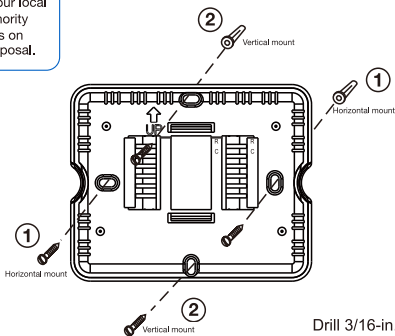

Drill 3/16-in. holes for drywall
Drill 3/16-in. holes for plaster

INSTALLATION TIPS

4 Connect Wires

Simply match wire labels to the letters on the thermostat.

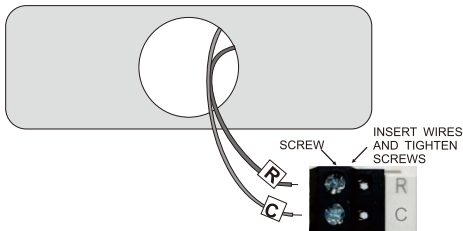

Installation Tip:

Do not overtighten terminal block screws, as this can damage the terminal block. A damaged terminal block can keep the thermostat from fitting on the subbase correctly or cause system operation issues. Max Torque = 6in-lbs.

5 Battery Installation

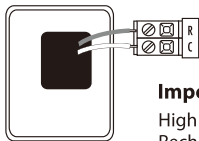

Battery installation is optional if used with AC power (the C terminal is connected). During power outages, the batteries will save settings and power the display.

Important:

High quality alkaline batteries are recommended. Rechargeable batteries or low quality batteries are not recommended.

Insert 2 AAA Alkaline batteries (included). High quality alkaline batteries are recommended.

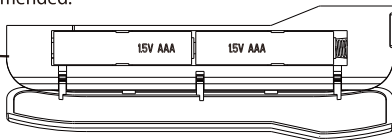

6 Mount Thermostat

Align the 4 tabs on the subbase with corresponding slots on the back of the thermostat, then push gently until the thermostat snaps in place.

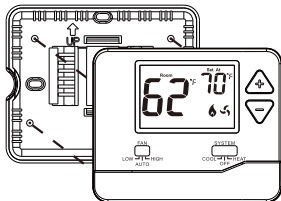

Terminal Designations

Terminal	1 Heat 1 Cool Conventional System	1 Heat 1 Cool Heat Pump System
R	Transformer power	Transformer power
C	Transformer common port	Transformer common port
B/O	Reversing Valve/ Configurable Terminal	Reversing Valve/ Configurable Terminal
GL	Fan Relay, Low	Fan Relay, Low
GH	Fan Relay, High	Fan Relay, High
W	First stage of heat	Second stage of heat
Y	First stage of cool	First stage of heat & cool

Wiring Tips

Use 18- to 22-gauge thermostat wire. Shielded wire is not required.

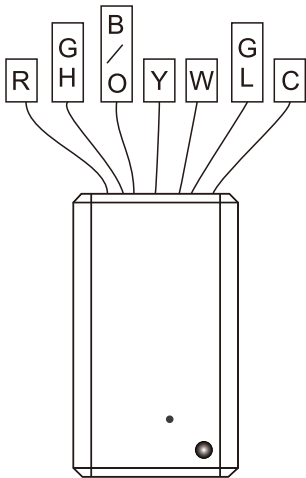

Note:

The base module may be mounted using adhesive tape, such as double-sided tape or hook and loop strips. The base module must be hardwired (C & R terminals connected to 24V power). Use secondary source of securement to prevent module from dropping into condenser drain pan.

Connecting to a PTAC:

When connecting the Base Module to a PTAC, refer to the PTAC manufacturer instructions to enable remote thermostat operation.



Wiring Note:

The base module is packaged with labeled thermostat wire. Wire appropriately into the PTAC board terminals.

WIRING DIAGRAMS

- 1 Power supply
- 2 Jumper (not supplied) to connect GL and GH terminals.
- 3 Thermostat must be set to O and B to match the changeover valve, O is the cool changeover valve, B is the heat changeover valve.
- 4 The Aux Heat Relay is energized as the second stage of heat.

Typical 1H/1C System: 2 Speed Fan

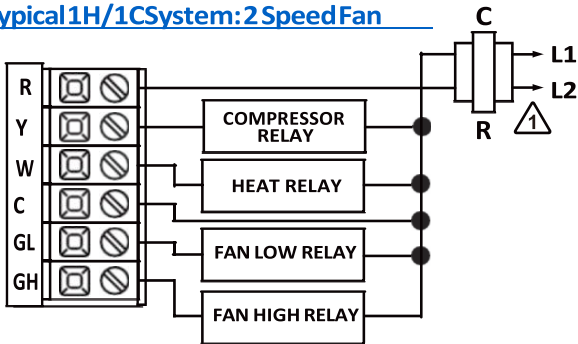

Typical 1H/1C System: 1 Speed Fan

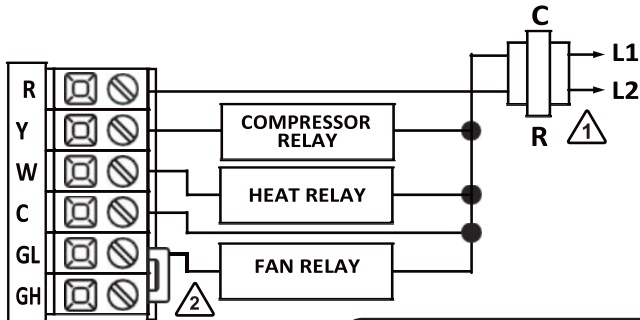

Note:

Most PTAC systems support two speed fan operation. In a single speed fan PTAC system or conventional single speed fan system, a jumper should be installed between GL and GH on the thermostat.

WIRING DIAGRAMS

Typical 1H/1C Heat Pump System: 2 Speed Fan

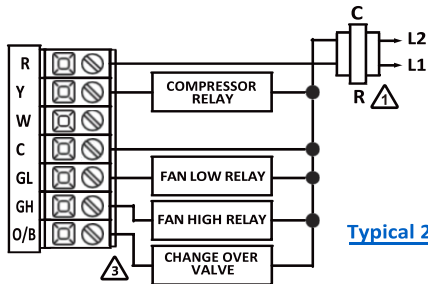

Typical 2H/1C Heat Pump System: 2 Speed Fan

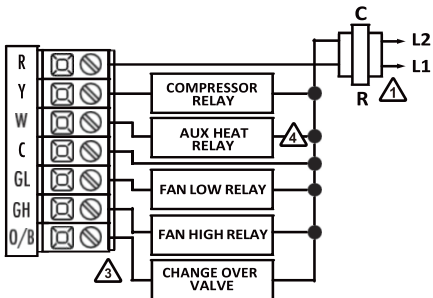

Fan Operation Setup

Electric: The thermostat operation jumper pin should be put in the ELEC position. This setting allows the thermostat to operate the fan during a call for heat. Most PTAC systems will require ELEC Fan Operation Setup.

Gas: For systems that control the fan during a call for heat, put the jumper pin into the GAS position.

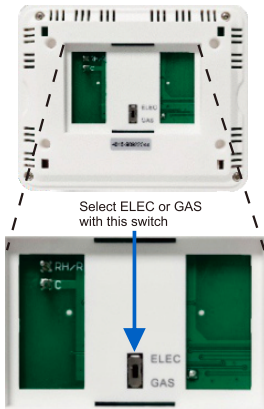

●Restore factory Settings:

Press and hold the “-” button, turn on the power, and release the factory Settings after the display is normal.

●HEAT SWING





Select HEAT with the system switch, hold down the + and - buttons together for 3 seconds to access the HEAT SWING setting. Use the + or - key to adjust the swing from $\pm 0.2^{\circ}\text{F}$ to $\pm 2^{\circ}\text{F}$. Wait approximately 15 seconds or slide the system switch to return to normal operation .

●COOL SWING











Select COOL with the system switch, hold down the + and - buttons together for 3 seconds to access the COOL SWING setting. Use the + or - key to adjust the swing from $\pm 0.2^{\circ}\text{F}$ to $\pm 2^{\circ}\text{F}$. Wait approximately 15 seconds or slide the system switch to return to normal operation.

Technician Setup Menu

1. Set the thermostat system switch to OFF.
2. To enter Tech Setup Menu, press and hold "+" and "-" together for 3 seconds.
3. Use "+" and "-" to select desired setting for each option.
4. Tap "+" and "-" together to move next option.
5. To exit Tech Setup Menu, move system switch or wait for 15 seconds.

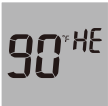
Tech Setup Steps		LCD Will Show	Adjustment Options	Default
Room Temperature Calibration	This feature allows the installer to change the calibration of the room temperature display. For example, if the thermostat reads 70° and you would like it to read 72° then select +2.	Calibration 	You can adjust the room temperature display to read up to 4° above or below the factory calibrated reading.	
Pair	Transmitter and receiver pair code		Press and hold "+" for 3 seconds until "LE" is flashed. Then release	
F or C	Select for Fahrenheit temperature read out select C for Celsius read out.		F for Fahrenheit C for Celsius	

TECHNICIAN SETUP

Tech Setup Steps	LCD Will Show	Adjustment Options	Default
<p>Compressor Short Cycle Delay</p>	<p>The compressor short cycle delay protects the compressor from short cycling. This feature will not allow the compressor to be turned on for 5 minutes after it was last turned off</p> 	<p>Selecting ON will not allow the compressor to be turned on for 5 minutes after the last time the compressor was switched off. Select OFF to remove this delay.</p>	
<p>Change Over Valve Selection</p>	<p>Select 0 for a changeover valve that energizes in cooling. Select b for a change over valve that energizes in heating.</p> 	<p>0 for cooling changeover valve. b for heating changeover valve.</p>	
<p>Heat Pump</p>	<p>When turned on the thermostat will operate a heat pump. Y will be the first stage of heat & cool, W will be the second stage of heat.</p> 	<p>OFF configures the thermostat for non heat pump systems. ON configures the thermostat for heat pump systems.</p>	
<p>Heating Temperature Setpoint Limit</p>	<p>This feature allows you to set a maximum heat setpoint value. The setpoint temperature cannot be raised above this value.</p> 	<p>Use the \square and \square key to select the maximum heat setpoint. Range 44°F- 90°F 7°C- 32°C</p>	
<p>Cooling Temperature Setpoint Limit</p>	<p>This feature allows you to set a minimum cool setpoint valve. The setpoint temperature cannot be lowered below this value.</p> 	<p>Use the \square and \square key to select the minimum cool setpoint. Range 44°F- 90°F 7°C- 32°C</p>	

The thermostat and receiver come factory linked out of the box. If however, communication is lost, follow this easy- **Two Step** process to re-establish the communication link.

1. RX: Press and hold the receiver learning button for 3 seconds. **The Red LED** will flash when it is ready to receive the paired signal from the **Thermostat**.
(Receiver must be 24V powered).
2. Transmitter: Turn the SYSTEM switch to OFF. Press and hold "+" and "-" together for 3 seconds to access the interface of room temperature calibration. Press and hold "+" and "-" together until "LE" is displayed on the LCD. Then press and hold "+" for 3 seconds, the transmitter will transmit the code signal. When the red LED on the receiver stops flashing, indicating that the code is successful.

Step 1.

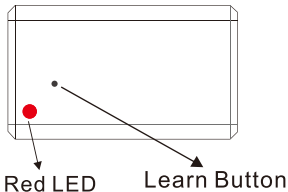

Step 2.

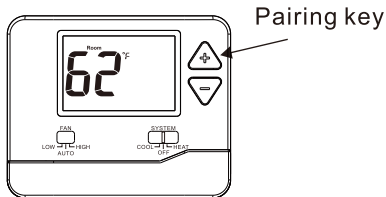

SPECIFICATIONS

Specifications

The display range of temperature ...	32°F to 99°F (0°C to 40°C)
The control range of temperature....	44°F to 90°F (7°C to 32°C)
Load rating.....	1 amp per terminal, 1.5 amp maximum all terminals combined
Swing (cycle rate or differential)	Heating is adjustable from 0.2° to 2.0° Cooling is adjustable from 0.2° to 2.0°
Power source	18 to 30 VAC, NEC Class II, 50/60 Hz for hardwire Battery power from 2 AAA Alkaline batteries
Operating ambient	32°F to +105°F (0°C to +41°C)
Operating humidity	90% non-condensing maximum
Dimensions of thermostat	120 x 98 x 28MM
Operating Frequency	915MHz

Instruction Manual