



AC System	
Location: _____ Engineer: _____ Submitted to: _____ Submitted by: _____ Reference: _____	Approval: _____ Date: _____ Construction: _____ Unit #: _____ Drawing #: _____

Set Code	22023110000867
Indoor unit code	22023111000251
Outdoor unit code	22023116000082
Set Model	
Indoor unit model	ACIQ-36-AHB
Outdoor unit model	ACIQ-36-AC
Certified	<div style="display: flex; align-items: center; gap: 10px;"> <div style="text-align: center;">  AHRI </div> <div style="text-align: center;">  <small>AHRI CERTIFIED</small> </div> <div style="text-align: center;">  UL US LISTED </div> </div>



SYSTEM PERFORMANCE DATA			
Power supply			
Normal Operational Voltage	(V, Ph, Hz)	208/230V, 1Ph,	60Hz
Voltage Range	(V)		187-253
Electrical			
Minimum circuit ampacity(Outdoor)	(A)		24.0
Max.fuse(Outdoor)	(A)		40.0
Connection wiring		14AWG*2	Stranded, shielded
Cooling			
Capacity	(Btu/h)	36000(8900~38900)	
Power Input	(W)	3560(320~4030)	
Current	(A)	15.82(2.60~17.90)	
SEER2	(Btu/W)		16.9
EER2	(Btu/W)		10.1

INDOOR UNIT DATA			
Indoor fan motor			
Model			ZKFD-375-8-1-1
Qty			1
Input	(W)		/
Output	(W)		/
RLA	(A)		27620.1
Speed(Hi/Mi/Lo)	(r/min)		/
Air flow & Noise level			
Indoor air flow (Hi/Med/Lo) (No duct)	(CFM)	1188.24/1082.35/970.59/864.71	
Indoor noise level (Hi/Med/Lo)	[dB(A)]		45.5/42.5/40
Dehumidification	(L/H)		3.62
Indoor unit			
Dimension (WxDxH)	(inch)	21.02x21.02x49.02	
	(mm)	534x534x1245	
Packing(WxDxH)	(inch)	26.57x24.41x52.56	
	(mm)	675x620x1335	
Net/Gross weight	(lbs.)	129.19/155.64	
	(kg)	58.6/70.6	
Accessories			
Adaptor for welding(3/4")	Qty		1
Adaptor for welding(3/8")	Qty		1

REFRIGERANT PIPE DATA			
Throttle type	Indoor unit	EEV for cooling	
	Outdoor unit		
Design pressure	(PSIG)	550/340	
Refrigerant Type		R410A	
Refrigerant charge	oz	130.51	
Refrigerant precharge	(ft)	25.0	
	(m)	7.5	
Additional charge for each ft	(oz/ft)	0.69	
Additional charge for each m	(g/m)	65.0	
Liquid side/ Gas side(indoor)	(inch)	3/8" / 3/4"	
	(mm)	9.52/19	
Liquid side/ Gas side(outdoor)	(inch)	3/8" / 3/4"	
	(mm)	9.52/19	
Max. pipe length	(ft)	213.3	
	(m)	65.0	
Max. difference in level	(ft)	98.4	
	(m)	30.0	
Connection method		Flared	
Indoor(cooling)	(Deg. °F)	60~90	
	(Deg. °C)	16~32	
Outdoor(cooling)	(Deg. °F)	5~122	
	(Deg. °C)	15~50	

OUTDOOR UNIT DATA			
Compressor			
Type			ROTARY
Model			KTF250D22UMT
Brand			GMCC
Capacity	(Btu/h)		27620
Input	(W)		2200
Rated current (RLA)	(A)		17.6
Refrigerant oil/oil charge	(ml)		VG74/670
Outdoor fan motor			
Model			ZKFN-120-8-2
Qty			1
Input	(W)		150.0
Output	(W)		120
RLA	(A)		1.5
Speed	(r/min)		1150/1050/900/850
Air flow & Noise level			
Outdoor air flow (Max.)	(CFM)		2235
Outdoor noise level	[dB(A)]		60.0
Outdoor unit			
Dimension (WxDxH)	(inch)	37.24x16.14x31.89	
	(mm)	946x410x810	
Packing (WxDxH)	(inch)	42.91x19.69x34.84	
	(mm)	1090x500x885	
Net/ Gross weight	(lbs.)	151.68/161.16	
	(kg)	68.8/73.1	
Accessories			
Adaptor for welding(3/4")	Qty		1
Adaptor for welding(3/8")	Qty		1
Adaptor (5/8" to 3/4")	Qty		1

Indoor unit dimension

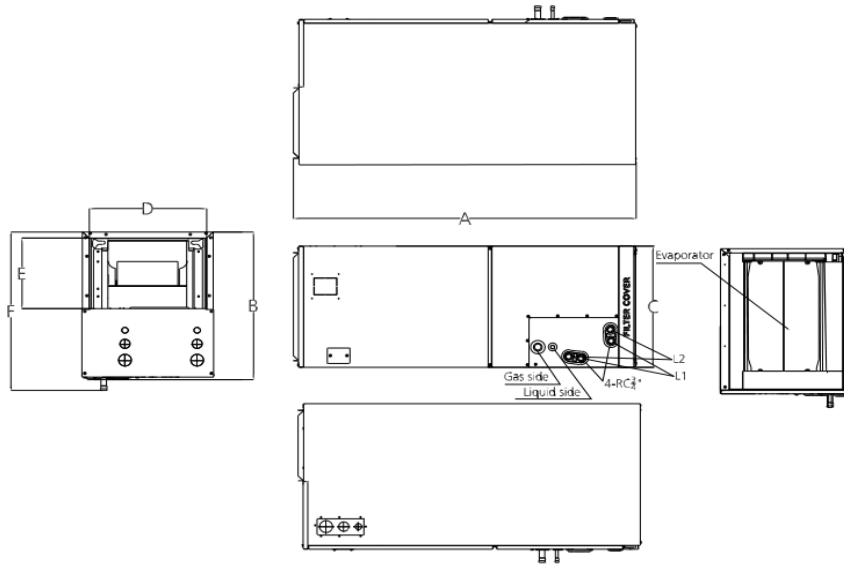

Model	Unit	Dimensions(mm)						Drain hole	
		A	B	C	D	E	F	L1	L2
18k~24k	mm	1143	534	445	400	260	585	Main drain	Overflow drain
	inch	45	21	17-1/2	15-3/4	10-1/4	23		
30k-48k	mm	1245	534	534	490	260	585		
	inch	49	21	21	19-5/16	10-1/4	23		
60k	mm	1346	534	622	580	260	585		
	inch	53	21	24-1/2	22-7/8	10-1/4	23		

Outdoor unit dimension

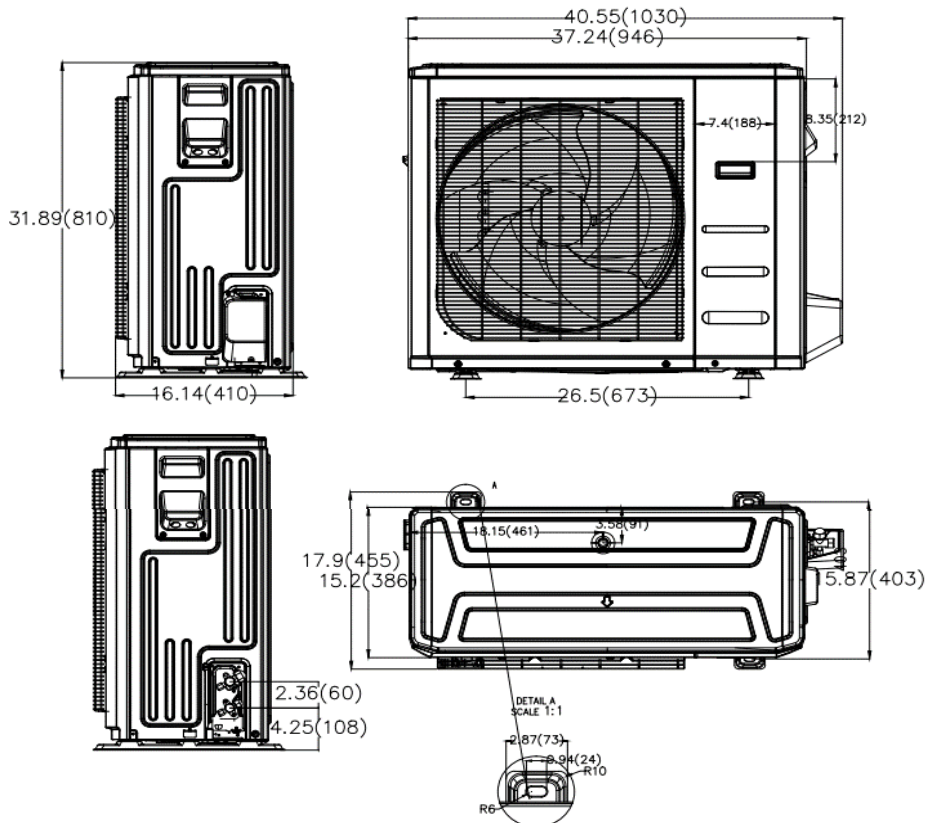

36K

