

ACiQ

R32 DUCTED AIR HANDLER & TOP-DISCHARGE HEAT PUMP CONDENSER

SERVICE MANUAL

Models Covered:

ACiQ-24TD-AH32

ACiQ-24TD-HP32

ACiQ-36TD-AH32

ACiQ-36TD-HP32

ACiQ-48TD-AH32

ACiQ-48TD-HP32

ACiQ-60TD-AH32

ACiQ-60TD-HP32



Contents

1 Product selection guidebook	5
1.1 Products list	5
1.1.1 Indoor unit lineup	5
1.1.2 Outdoor unit lineup.....	6
1.3 Air volume static pressure curve	7
1.4 Noise	9
1.4.1 Indoor unit.....	9
1.4.2 Outdoor unit.....	11
2 Installation manual.....	13
2.1 Installation preparation.....	13
2.1.1 Notice on Installation.....	13
2.1.2 Unit dimension	20
2.2 Unit installation.....	23
2.2.1 Indoor unit installation	23
2.2.2 Outdoor unit installation	28
2.2.3 Piping connection.....	29
2.2.4 Vacuum and leak detection	35
2.2.5 Refrigerant adding	36
2.2.6 Installation of drain pipe	37
2.2.7 Installation of the duct	39



- 2.3 Electrical installation..... 41
 - 2.3.1 Requirement and notice of electrical installation 41
 - 2.3.2 Electrical parameters 44
 - 2.3.3 Connection of power cord and communication cord 45
- 2.4 Check after installation..... 47
- 2.5 Test running 47
- 3. Maintenance instruction manual..... 13
 - 3.1 Control 52
 - 3.1.1 Operation mode 52
 - 3.1.2 Control mode 52
 - 3.1.3 Functions 54
 - 3.2 troubleshooting 56
 - 3.2.1 Wiring diagrams 56
 - 3.2.2 PCB Layout..... 58
 - 3.2.3 Error codes 60
 - 3.2.4 Trouble shooting 63
 - 3.2.5 Failures Not Caused by Errors..... 85
 - 3.3 Maintenance 86
 - 3.3.1 System diagram 86
 - 3.3.2 Connection pipe vacuum pumping..... 87
 - 3.3.3 Refrigerant charging..... 87
 - 3.3.4 Maintenance of major components 88

- 3.3.5 Removal of major components 89
- 3.3.6 Explosive view and parts list 97
- 3.4 Appendices 108
 - 3.4.1 Resistance/Temperature Lists of Temperature Sensors 108
 - 3.4.2 Temperature / Pressure list of Refrigerant 113
 - 3.4.3 Operation tools 113
- 4. Parameter query 114
 - 4.1 Operation and display 114
 - 4.1.1 The way to enter the parameter query 114
 - 4.1.2 Switch parameter codes 114
 - 4.1.3. Exit parameter query 115
 - 4.2 Indoor unit PCB dial codes 116



1 Product selection guidebook

1.1 Products list

1.1.1 Indoor unit lineup

Model	Nominal Capacity Cooling/Heating	Power Supply (V, Ph, Hz)	Appearance	Features
24K ACIQ-24TD-AH32	24000/24000 (Btu/h)	208-230V~ 1 ph 60Hz		R32 refrigerant AC motor, max. static pressure 200Pa Compatible with 24V&RS485 communication
36K ACIQ-36TD-AH32	36000/36000 (Btu/h)	208-230V~ 1 ph 60Hz		
48K ACIQ-48TD-AH32	48000/48000 (Btu/h)	208-230V~ 1 ph 60Hz		Built-in EEV Built-in refrigerant leakage sensor Aluminum tube heat exchanger
60K ACIQ-60TD-AH32	54000/54000 (Btu/h)	208-230V~ 1 ph 60Hz		

1.1.2 Outdoor unit lineup

Model	Nominal Capacity Cooling/Heating	Power Supply (V, Ph, Hz)	Appearance	Features
24K ACIQ-24TD-HP32	24000/24000 (Btu/h)	208-230V~ 1 ph 60Hz		R32 refrigerant DC motor, Compatible with 24V&RS485 communication Built-in EEV
36K ACIQ-36TD-HP32	36000/36000 (Btu/h)	208-230V~ 1 ph 60Hz		
48K ACIQ-48TD-HP32	48000/48000 (Btu/h)	208-230V~ 1 ph 60Hz		
60K ACIQ-60TD-HP32	54000/54000 (Btu/h)	208-230V~ 1 ph 60Hz		

1.2 Air volume static pressure curve

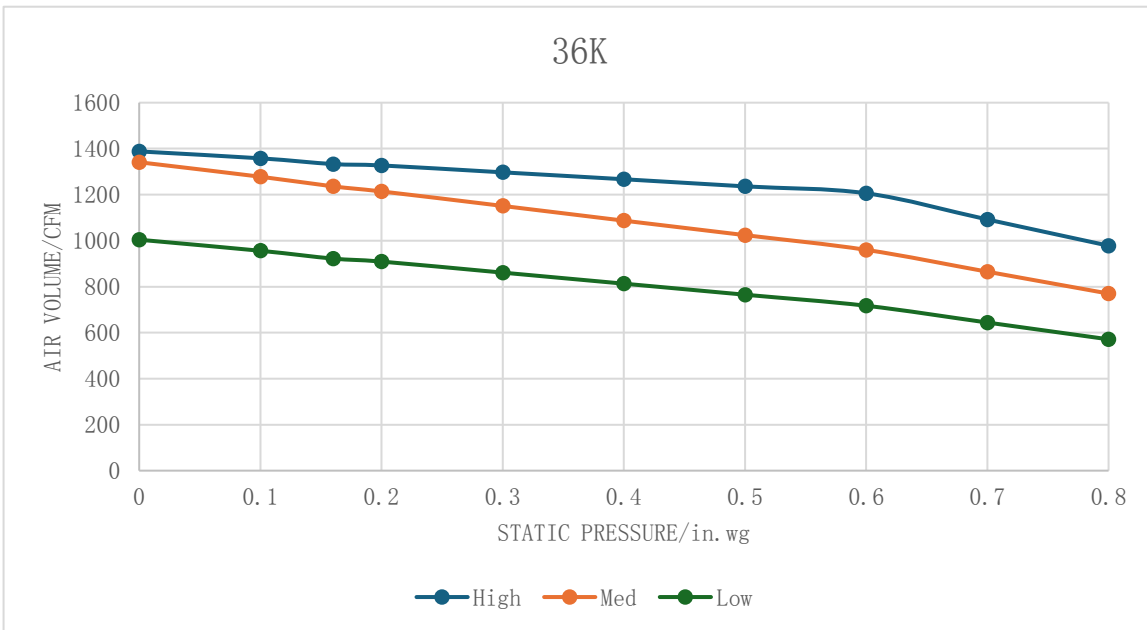
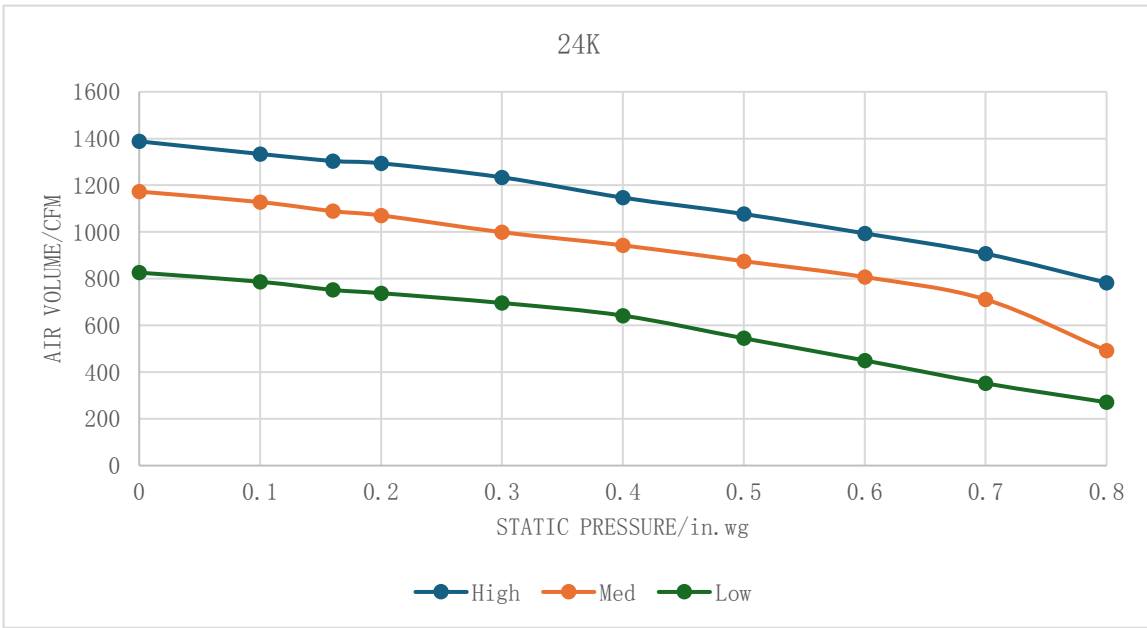

48K

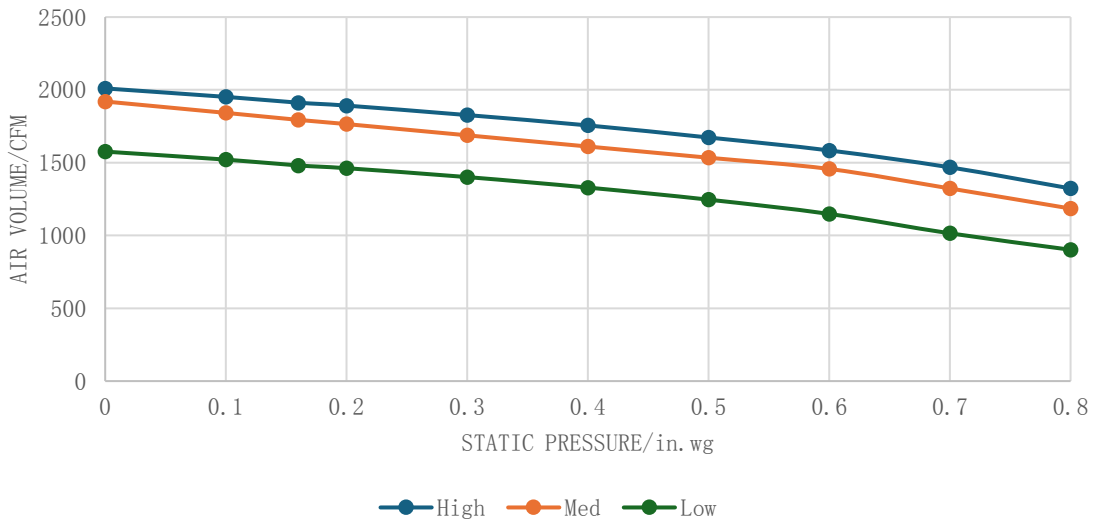

60K

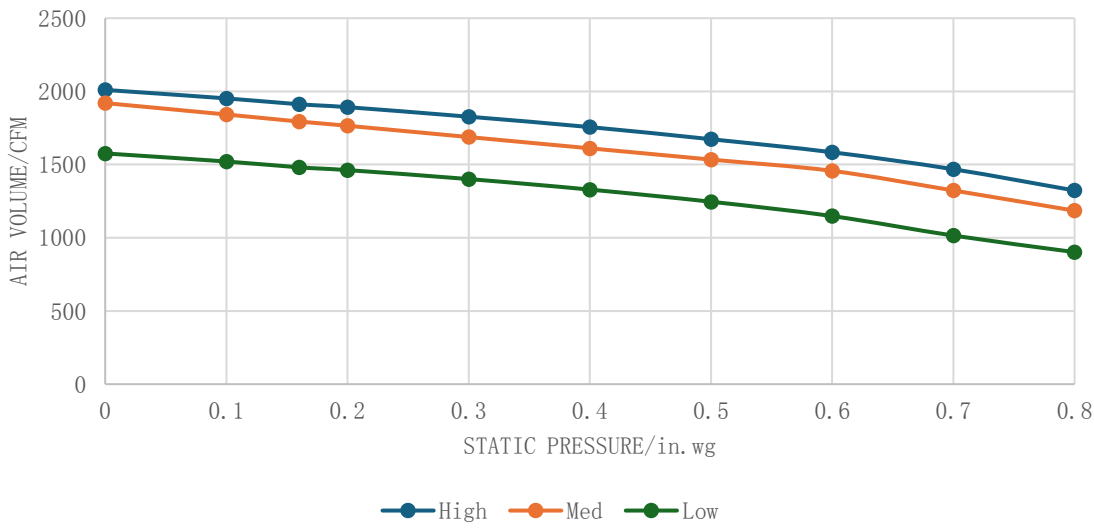

1.3 Noise

1.3.1 Indoor unit

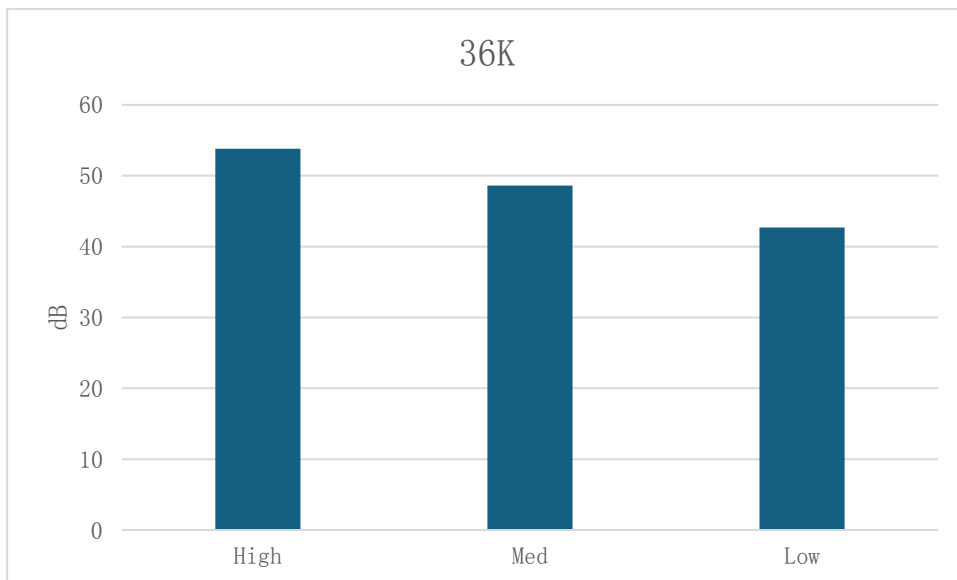
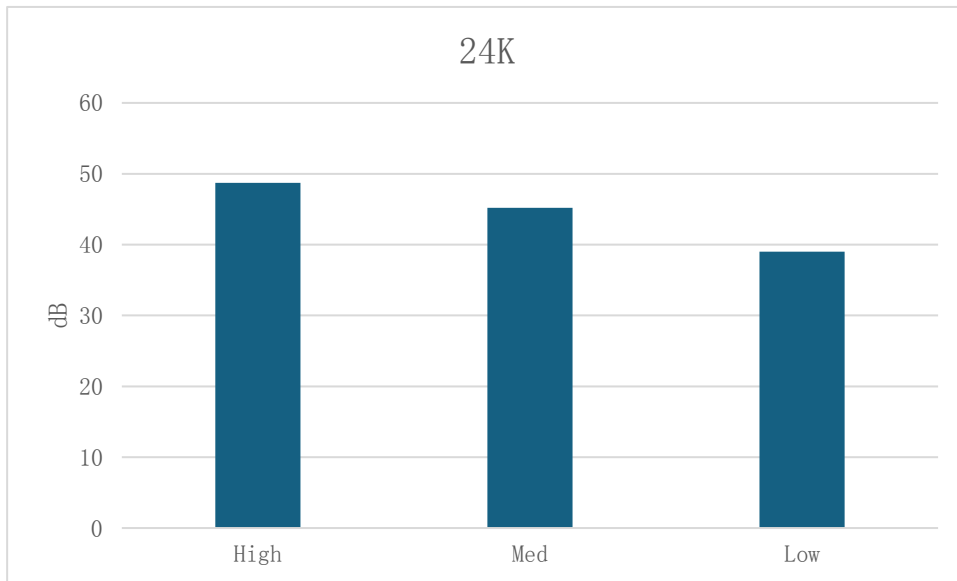

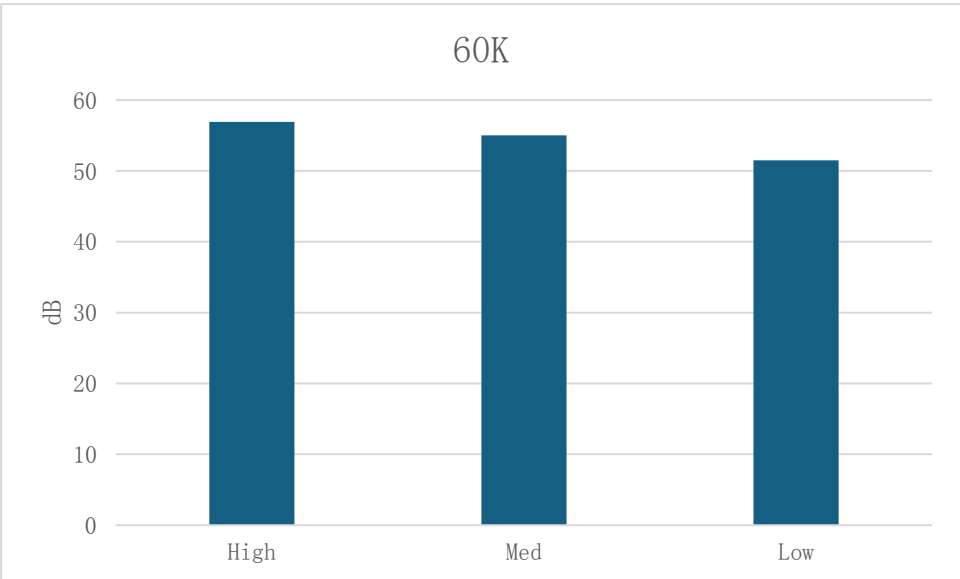
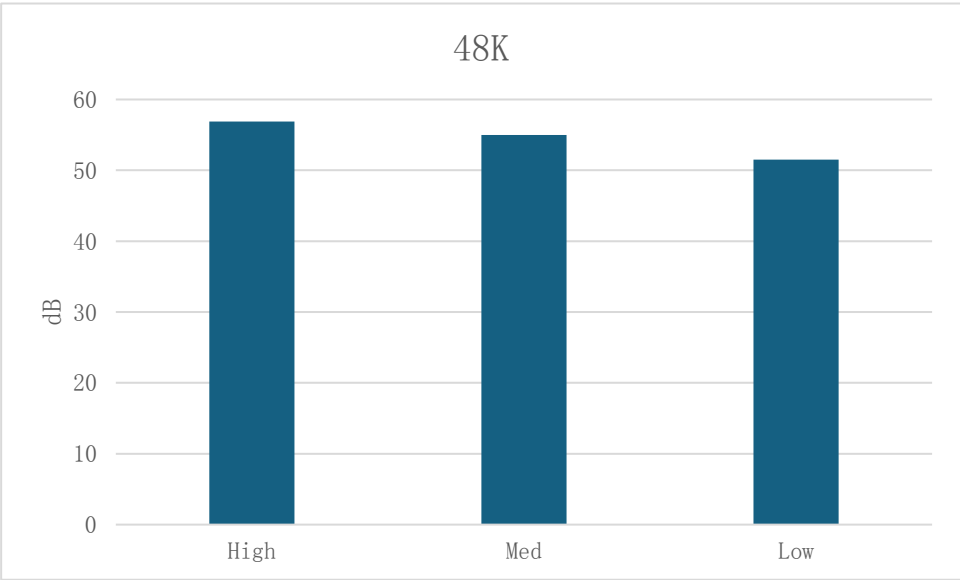

1.3.2 Outdoor unit

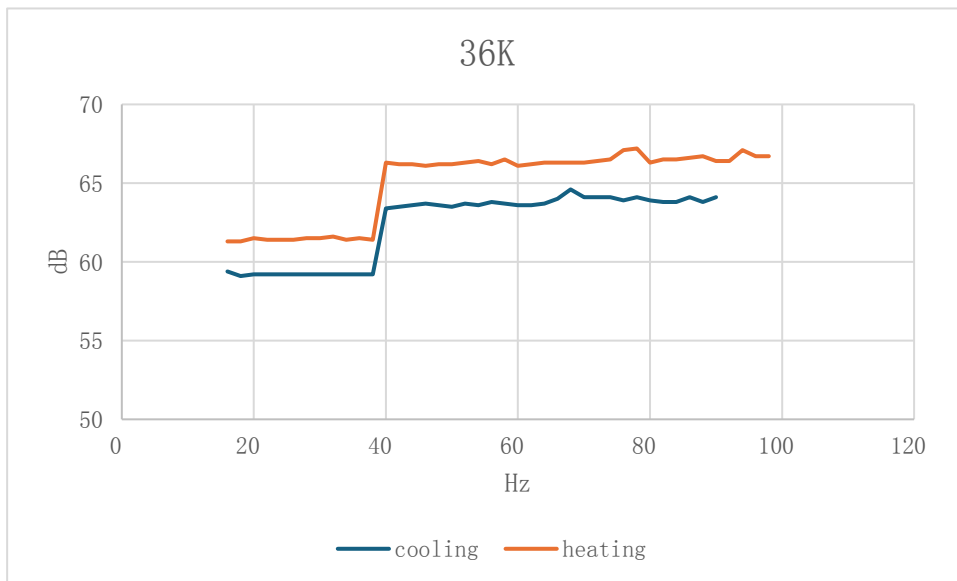
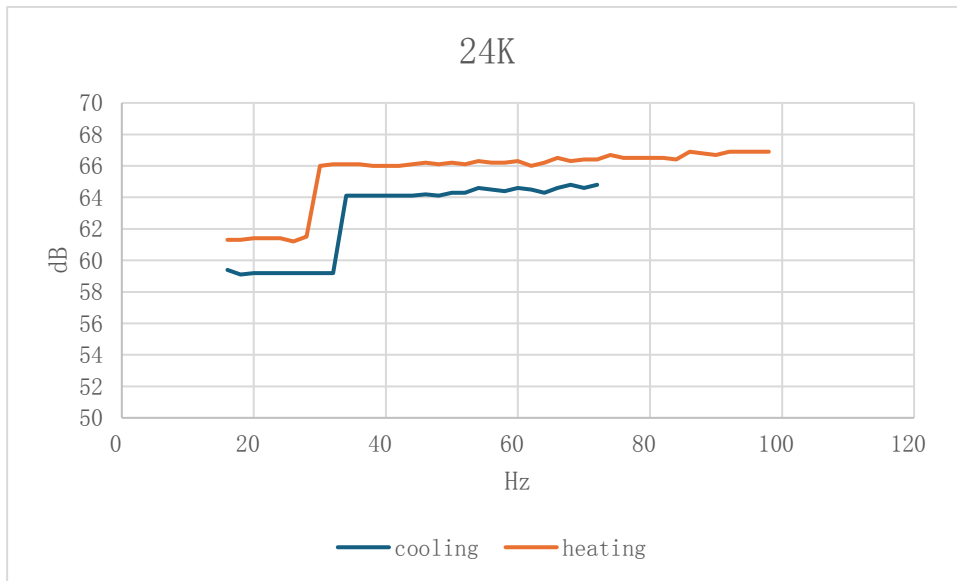

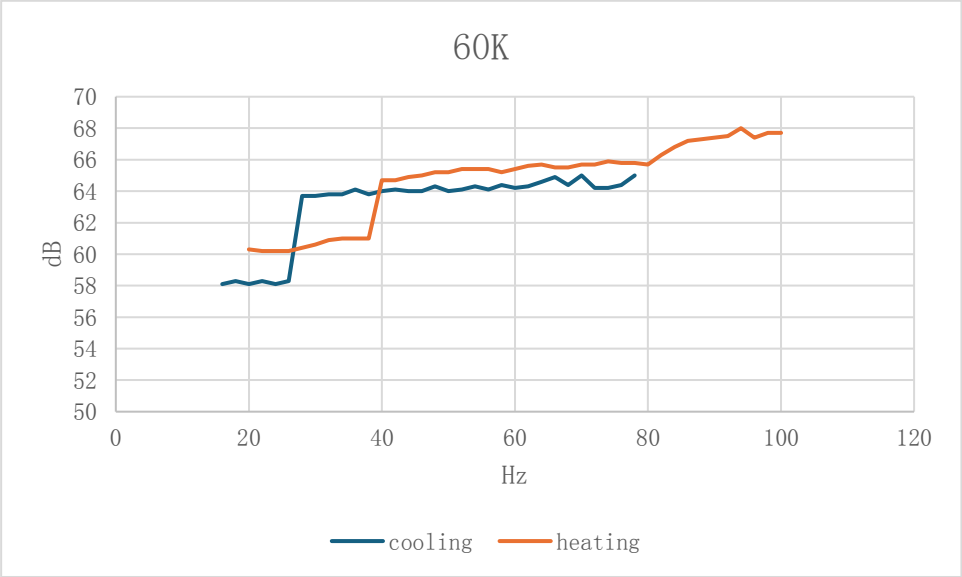
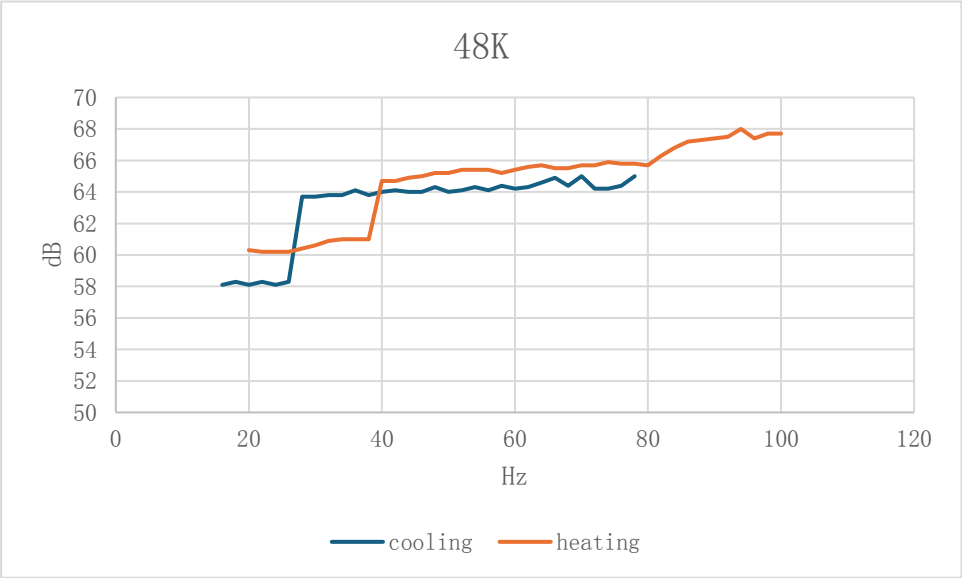

2 Installation manual

2.1 Installation preparation

2.1.1 Notice on Installation

Important Considerations

1. The air conditioner must be installed by professional personnel and the Installation manual is specially used for the professional technician. The installation specifications should be subject to our after-sale service regulations.
2. When filling the combustible refrigerant, any of your rude operations may cause serious injury or injuries to human body and objects.
3. A leak test must be done after the installation completed.
4. It is a must to do the safety inspection before maintaining or repairing an air conditioner using combustible refrigerant in order to ensure that the fire risk is reduced to minimum.
5. It is necessary to operate the machine under a controlled procedure in order to ensure that any risk arising from the combustible gas or vapor during the operation is reduced to minimum.
6. Requirements for the total weight of filled refrigerant and the area of a room to be equipped with an air conditioner (shown in the following tables)

The maximum charge and the required minimum floor area

$$m_1 = (6 \text{ m}^3) \times \text{LFL}, m_2 = (52 \text{ m}^3) \times \text{LFL}, m_3 = (260 \text{ m}^3) \times \text{LFL}$$

Where LFL is the lower flammable limit in kg/ m³, R32 LFL is 0.306 kg/ m³.

For the appliances with a charge amount $m_1 < M = m_2$:

The maximum charge in a room shall be in accordance with the following:

$$M_{\max} = \text{SF} \times \text{LFL} \times h_0 \times A$$

The required minimum floor area A_{\min} to install an appliance with refrigerant charge M (kg) shall be in accordance with following: $A_{\min} = M / (\text{SF} \times \text{LFL} \times h_0)$

Refrigerant Charge and Room Area Limitations

In UL/CSA 60335-2-40, R32 refrigerant is classified as class A2L, which is mildly flammable.

Therefore, R32 refrigerant is suitable for systems needing additional refrigerant charge and which will limit the area of the rooms being served by the system. Similarly, the total amount of refrigerant in the system shall be less than or equal to the allowable maximum refrigerant charge. The allowable maximum refrigerant charge depends on the area of the rooms being served by the system.

NOTE

The nouns in this section are explained as follows:

M_c : The actual refrigerant charge in the system.

A : the actual room area where the appliance is installed.

A_{\min} : The required minimum room area.

M_{\max} : The allowable maximum refrigerant charge in a room.

Q_{\min} : The minimum circulation airflow.

$A_{\text{nv}_{\min}}$: The minimum opening area for connected rooms.

TA_{\min} : The total area of the conditioned space (For appliances serving one or more rooms with an air duct system).

TA : The total area of the conditioned space connected by air ducts.

1. The room area calculation requirements

CAUTION

The space considered shall be any space which contains refrigerant-containing parts or into which refrigerant could be released. The room area (A) of the smallest, enclosed, occupied space shall be used in the determination of the refrigerant quantity limits.

For determination of room area (A) when used to calculate the refrigerant charge limit, the following shall apply.

The room area (A) shall be defined as the room area enclosed by the projection to the base of the walls, partitions and doors of the space in which the appliance is installed.

Spaces connected by only drop ceilings, ductwork, or similar connections shall not be considered a single space.

Units mounted higher than 70-55/64 inches and spaces divided by partition walls that are no higher than 62-63/64 inches shall be considered a single space.

Rooms on the same floor and connected by an open passageway between the spaces can be considered a single room when determining compliance to A_{min} , if the passageway complies with all of the following.

- 1) It is a permanent opening.
- 2) It extends to the floor.
- 3) It is intended for people to walk through.

The area of the connected rooms, on the same floor, connected by permanent opening in the walls and/or doors between occupied spaces, including gaps between the wall and the floor. Can be considered a single room when determining compliance to A_{min} , provided all of the following conditions are met as Fig.2-1.

1) Low level opening

- ① The opening shall not be less than Anv_{min} in Table2-1.
- ② The area of any openings above 11-13/16 inches from the floor shall not be considered in determining compliance with Anv_{min} .
- ③ At least 50% of the opening area of Anv_{min} shall be below 7-7/8 inches from the floor.
- ④ The bottom of the opening is not more than 3-15/16 inches from the floor.
- ⑤ The opening is a permanent opening that cannot be closed.
- ⑥ For openings extending to the floor the height shall not be less than 25/32 inches above the surface of the floor covering.

2) High level opening

- ① The opening shall not be less than 50% of Anv_{min} in Table2-1.
- ② The opening is a permanent opening that cannot be closed.
- ③ The opening shall be at least 59 inches above the floor.
- ④ The height of the opening is not less than 25/32 inches.

3) Room size requirement

- ① The room into which refrigerant can leak, plus the connected adjacent room(s) shall have a total area not less than A_{min} . A_{min} is shown in Table2-3.
- ② The room area in which the unit is installed shall be not less than 20% A_{min} . A_{min} is shown in Table2-3.

NOTE

The requirement for the second opening can be met by drop ceilings, ventilation ducts, or similar arrangements that provide an airflow path between the connected rooms.

The minimum opening for natural ventilation ($A_{n\min}$) in connected rooms is related to the room area (A), the actual refrigerant charge in the system (M_c), and the allowable maximum refrigerant charge in the system (M_{\max}).

$A_{n\min}$ can be determined according to Table 2-1.

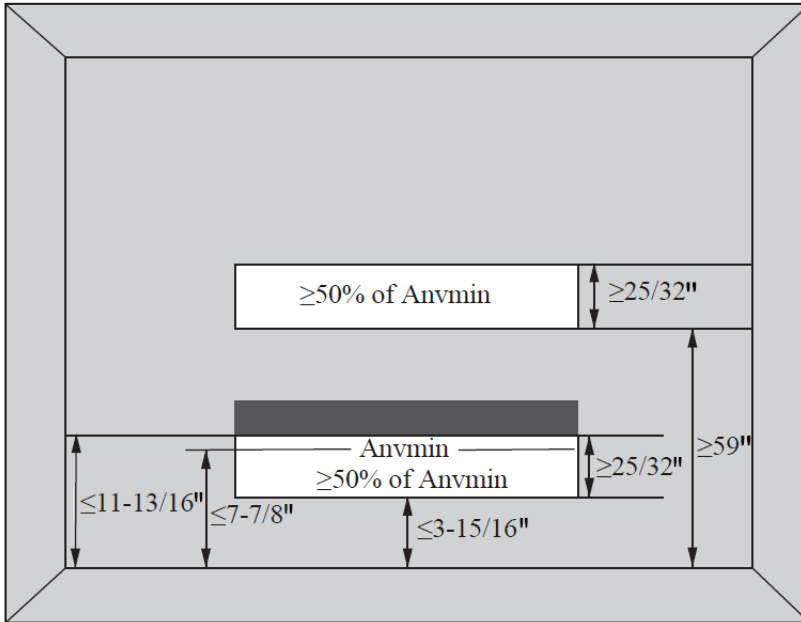

The minimum opening area for connected rooms

Table 2-1

A(ft ²)	M _c (□lbs□oz)		M _{max} (□lbs□oz)		A _{nmin} (ft ²)
	lbs	oz	lbs	oz	
40	7	12	2	12	0.7
50	7	12	3	7	0.6
60	7	12	4	2	0.5
70	7	12	4	13	0.4
80	7	12	5	8	0.3
90	7	12	6	3	0.2
100	7	12	6	14	0.1
110	7	12	7	9	0.1
120	7	12	8	4	0.0
130	7	12	8	15	0.0
140	7	12	9	10	0.0
150	7	12	10	4	0.0
160	7	12	10	10	0.0

Note: Take the $M_c=7$ lbs 12 oz as an example.

For appliances serving one or more rooms with an air duct system, the room area calculation shall be

determined based on the total area of the conditioned space (TA) connected by ducts taking into consideration that the circulating airflow distributed to all the rooms by the appliance integral indoor fan will mix and dilute the leaking refrigerant before entering any room.

2. The allowed maximum refrigerant charge and required minimum room area

If the fan incorporated to an appliance is continuously operated or operation is initiated by a REFRIGERANT DETECTION SYSTEM with a sufficient CIRCULATION AIRFLOW rate, the allowable maximum refrigerant charge (M_{max}) and the required minimum room area (A_{min}/TA_{min}) is shown in Table 2-2 and Table 2-3.

The allowable maximum refrigerant charge

Table 2-2

A/TA(ft ²)	Mmax(□lbs□oz)		A/TA(ft ²)	Mmax(□lbs□oz)	
	lbs	oz		lbs	oz
40	2	12	160	10	9
50	3	7	170	10	15
60	4	2	180	11	4
70	4	13	190	11	9
80	5	8	200	11	13
90	6	3	210	12	2
100	6	14	220	12	7
110	7	9	230	12	11
120	8	4	240	13	0
130	8	15	250	13	4
140	9	10	260	13	8
150	10	4			

The required minimum room area

Table 2-3

Mc(□lbs□oz)		Amin/Tamin(ft ²)	Mc(□lbs□oz)		Amin/Tamin(ft ²)
lbs	oz		lbs	oz	
4	0	58.1	11	0	171.3
4	8	65.4	11	8	187.2
5	0	72.6	12	0	203.9
5	8	79.9	12	8	221.2
6	0	87.1	13	0	239.3
6	8	94.4	13	8	258.0
7	0	101.6	14	0	277.5
7	8	108.9	14	8	297.6
8	0	116.2	15	0	318.5
8	8	123.4	15	8	340.1
9	0	130.7	16	0	362.4
9	8	137.9	16	8	385.4
10	0	145.2	17	0	409.1
10	8	156.1	17	8	433.5

The minimum circulation airflow

Table 2-4

Mc(□lbs□oz)		Qmin(CFM)	Mc(□lbs□oz)		Qmin(CFM)
lbs	oz		lbs	oz	
4	0	105	11	0	289
4	8	118	11	8	302
5	0	131	12	0	315
5	8	145	12	8	328
6	0	158	13	0	341
6	8	171	13	8	354
7	0	184	14	0	367
7	8	197	14	8	380
8	0	210	15	0	393
8	8	223	15	8	406
9	0	236	16	0	419
9	8	249	16	8	433
10	0	262	17	0	446
10	8	275	17	8	459

CAUTION

The allowable maximum refrigerant charge of the Table 2-2 or the required minimum room area of the Table 2-3 is available only if the following conditions are met:

Minimum velocity of 3.28ft/s, which is calculated as the indoor unit airflow divided by the nominal face area of the outlet. And the grill area shall not be deducted.

Minimum airflow rate must meet the corresponding values in Table 2-4, which is related to the actual refrigerant charge of the system (Mc).

R32 refrigerant leakage sensor is configured.

If the safety protection function depends on continuous air circulation, the following shall apply:

Continuous air circulation is required for proper operation. The unit must remain powered on except during maintenance.

NOTE

The maximum refrigerant limit described above applies to unventilated areas. If adding additional measures, such as areas with mechanical ventilation or natural ventilation, the maximum refrigerant charge can be increased or the minimum room area can be reduced.

R32 refrigerant leakage sensor is configured for the indoor unit, meets the incorporated circulation airflow requirements, the maximum refrigerant charge or minimum room area can be determined according to Table 2-2 or Table 2-3.

CAUTION

If the actual room area, air outlet height, and refrigerant charge amount are not reflected in the above table. more severe cases need to be considered according to the data in the table 2-1, 2-2, 2-3, 2-4.

1. Site Safety



Open Flames Prohibited



Ventilation Necessary

2. operation safety



Mind Static Electricity



Must wear protective clothing and anti-static gloves



Don't use mobile phone

3. Installation Safety

Refrigerant Leak Detector

Appropriate Installation Location





















The left picture is the schematic diagram of a refrigerant leak detector.

Please note that:

1. The installation site should be well-ventilated.
2. The sites for installing and maintaining an air conditioner using Refrigerant R32 should be free from open fire or welding, smoking, drying oven or any other heat source higher than **396°F** which easily produces open fire.
3. When installing an air conditioner, it is necessary to take appropriate anti-static measures such as wear anti-static clothing and/or gloves.
4. It is necessary to choose the site convenient for installation or maintenance wherein the air inlets and outlets of the indoor and outdoor units should be not surrounded by obstacles or close to any heat source or combustible and/or explosive environment.
5. If the indoor unit suffers refrigerant leak during the installation, it is necessary to immediately turn off the valve of the outdoor unit and all the personnel should go out till the refrigerant leaks completely for 15 minutes. If the product is damaged, it is a must to carry such damaged product back to the maintenance station and it is prohibited to weld the refrigerant pipe or conduct other operations on the user's site.
6. It is necessary to choose the place where the inlet and outlet air of the indoor unit is even.
7. It is necessary to avoid the places where there are other electrical products, power switch plugs and sockets, kitchen cabinet, bed, sofa and other valuables right under the lines on two sides of the indoor unit.

Suggested Tools

Tool	Picture	Tool	Picture	Tool	Picture
Standard Wrench		Pipe Cutter		Vacuum Pump	
Adjustable/ Crescent Wrench		Screw drivers (Phillips & Flat blade)		Safety Glasses	
Torque Wrench		Manifold and Gauges		Anti-static Gloves	
Hex Keys or Allen Wrenches		Level		Refrigerant Scale	
Drill & Drill Bits		Flaring tool		Micron Gauge	
Hole Saw		Clamp on Amp Meter		Welding Gun	

Dedicated Distribution Device and Wire for Air Conditioner

Min. Circuit Ampacity of Air Conditioner (A)	Minimum Wire Cross- sectional Area(mm ²)	Specification of Socket or Switch(A)	Fuse Specification(A)
≤8	0.75	15	15
>8 and ≤10	1.0	15	15
>10 and ≤15	1.5	20	25
>15 and ≤24	2.5	25	40
>24 and ≤28	4.0	35	45
>28 and ≤32	6.0	40	55

NOTE

The table above for reference only, the installation shall meet the requirements of local laws and regulations.

2.1.2 Unit dimension

2.1.2.1 Indoor unit dimension

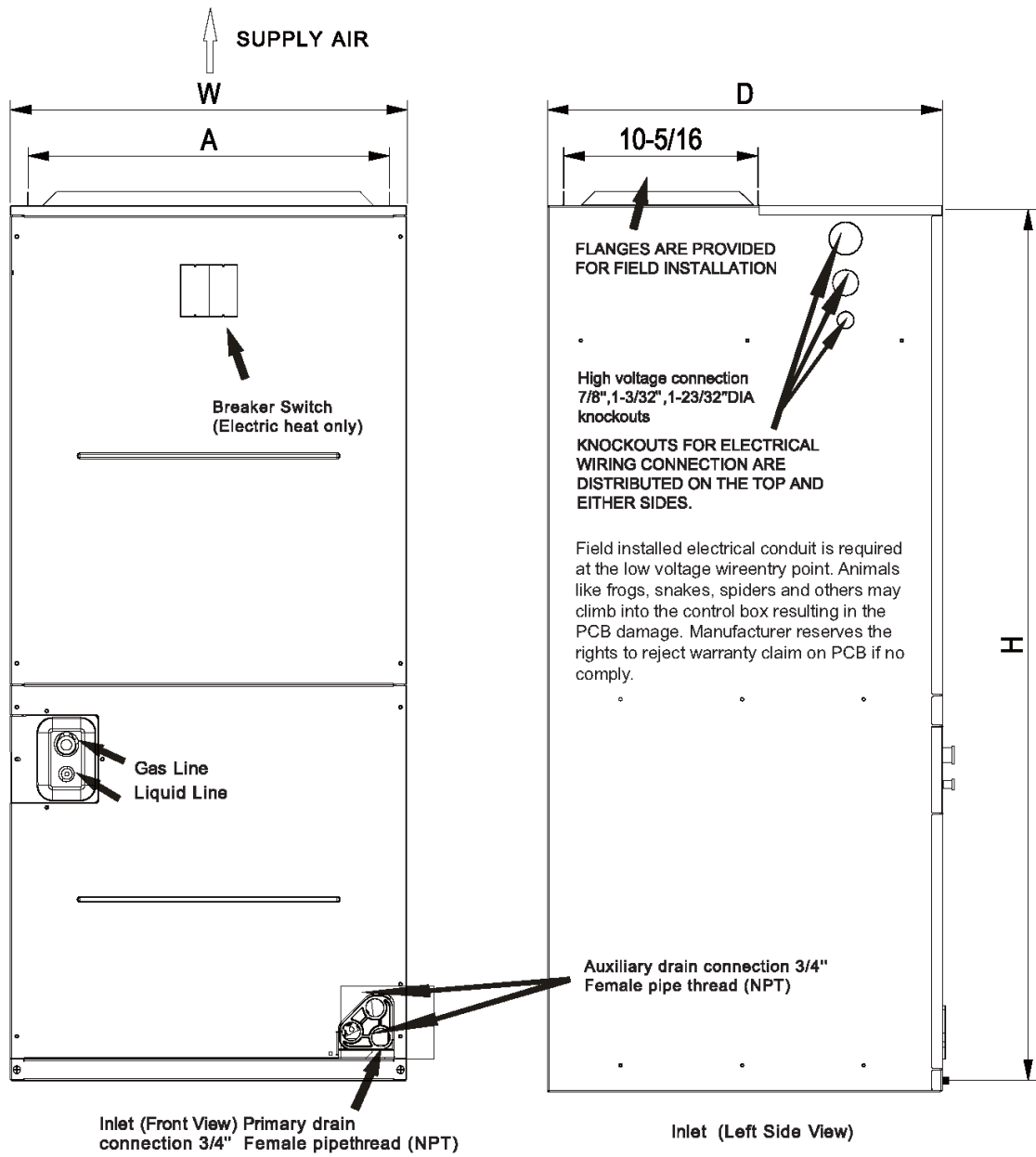

Unit dimensions

Model	Dimensions (in.)					
	H	W	D	A	Liquid Line Connection	Gas Line Connection
24K ACiQ-24TD-AH32 36K ACiQ-36TD-AH32	46-1/2	21	21	19-1/4	3/8	3/4
48K ACiQ-48TD-AH32 60K ACiQ-60TD-AH32	56	24-1/2	21	22-3/4	3/8	7/8

2.1.2.2 Outdoor unit dimension

Two models sharing the same chassis are suit for most residential air conditioner and heat pump applications. When mounting the condensing unit on a roof or pad, be sure its dimension no less than 29" x 29".

Table 4-1 Condensing unit dimensions

Unit Dimensions	
Model	HxWxD(Inches)
24K	24-15/16x29-1/8x29-1/8
36K	24-15/16x29-1/8x29-1/8
48K	33-3/16x29-1/8x29-1/8
60K	33-3/16x29-1/8x29-1/8

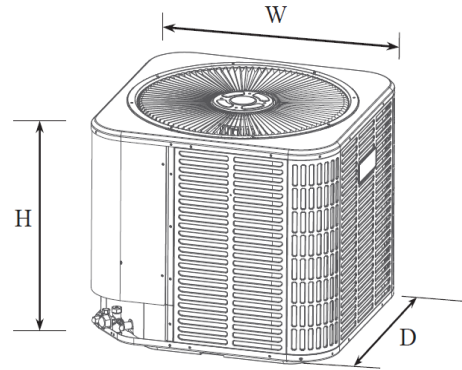

2.1.3 Diagram of unit installation space

2.1.3.1 Diagram of installation space and location for outdoor unit

Installation Clearance Requirement

Ensure the top discharge area is unrestricted for at least 60 inches above the unit.

Do not locate condensing unit near bedrooms because normal operational sounds may be annoying. Position unit to allow adequate space for unobstructed airflow, wiring, refrigerant pipes, and serviceability.

Allow a minimum of 12 in. clearance on one side of access panel to a wall and a minimum of 24 in. on the adjacent side of access panel. Maintain a distance of 24 in. between units.

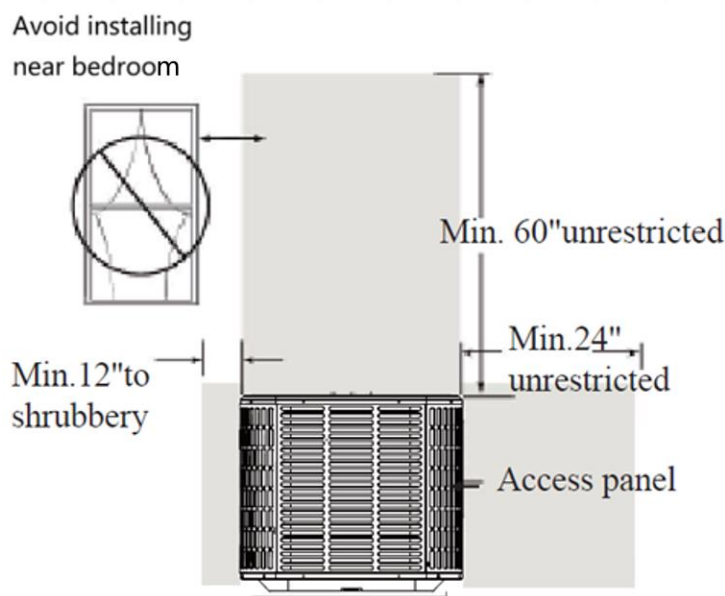

Do not choose the installation location on the roof to avoid rain, ice and snow falling directly on the top of the unit.

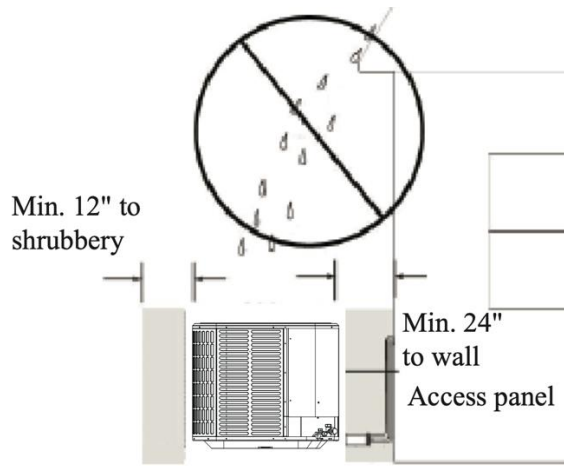

2.1.3.2 Diagram of installation location and space for indoor unit

a) Horizontal position

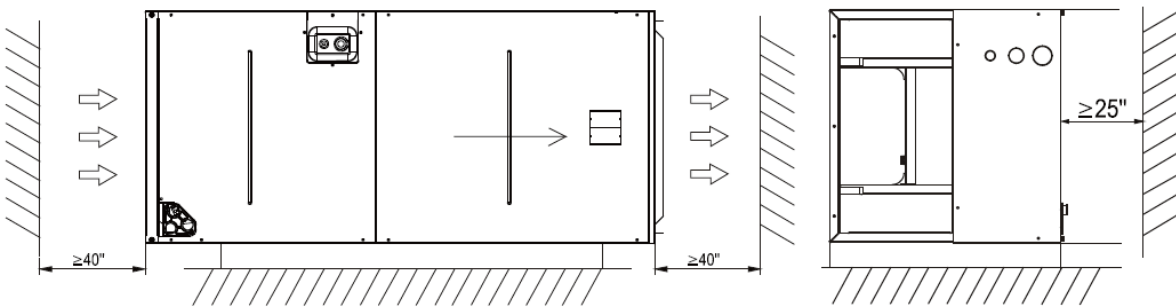

b) Vertical position Clearance requirement

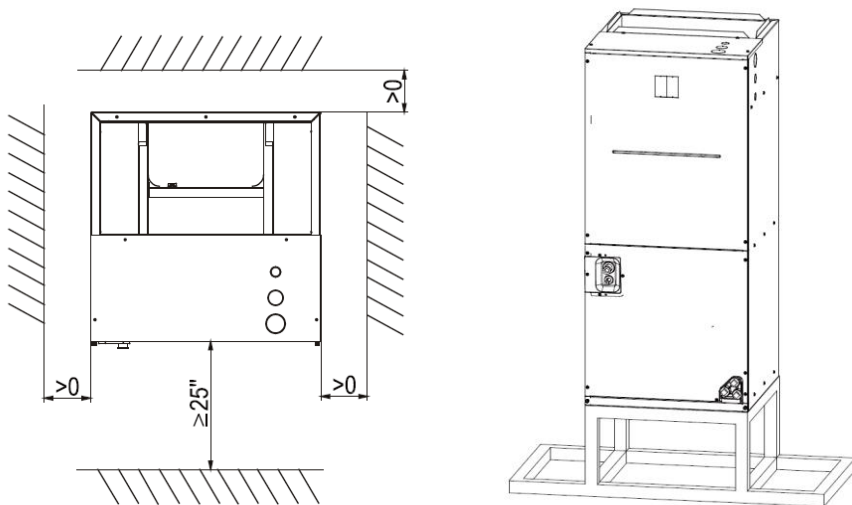

2.2 Unit installation

2.2.1 Indoor unit installation

Vertical up-flow and horizontal right-slow configurations are factory settings on all models. If return air is to be ducted, install duct flush with floor. Use fireproof resilient gasket 1/8" to 1/4" thick between the ducts, unit and floor. Set unit on floor over opening.

IMPORTANT

Lightly tighten the drain connections so they do not leak.

Using excessive force may cause damage to the drain connections. Torque applied to drain connections should NOT exceed 10.ft.lbs.

Dimension from unit front below

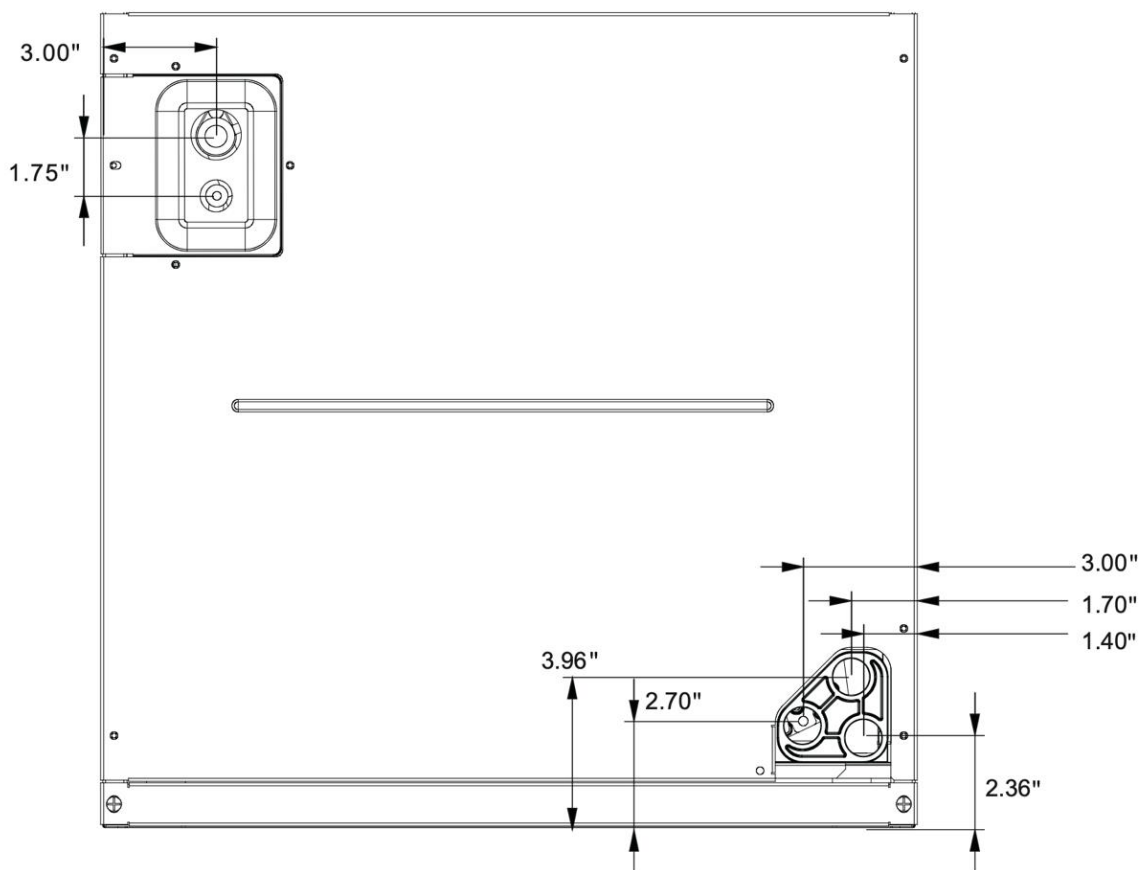

NOTE

The unit can be installed in a Vertical (Down and Up) and Horizontal (Right and Left) configuration shown as following.

Vertical installation

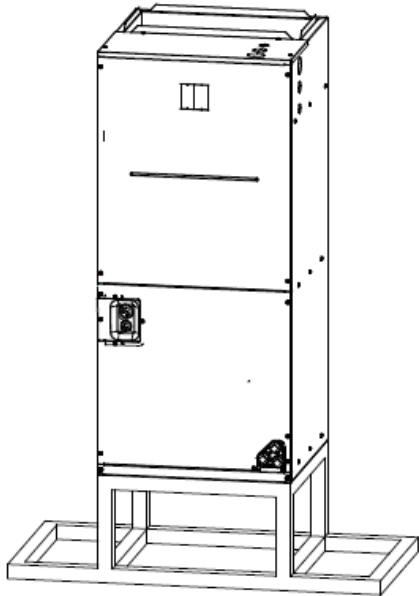

Horizontal installation

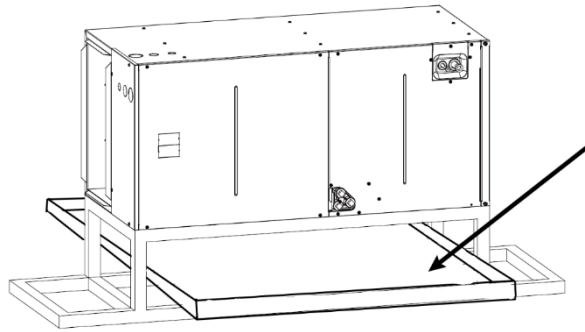

Note: For horizontal installation, a secondary drain pan (not supplied) is suggested to install under the unit to prevent water leakage.

Please follow these steps to perform Vertical up installation and Horizontal right installation:

1. Open the upper cover.
2. Open the cover of the electronic control box.
3. Connect the wire according to the wiring diagram.
4. Connect the pipes.
5. Install the drainage pipes.

The unit installed as Upflow, Downflow, Horizontal Left and Horizontal Right orientations.

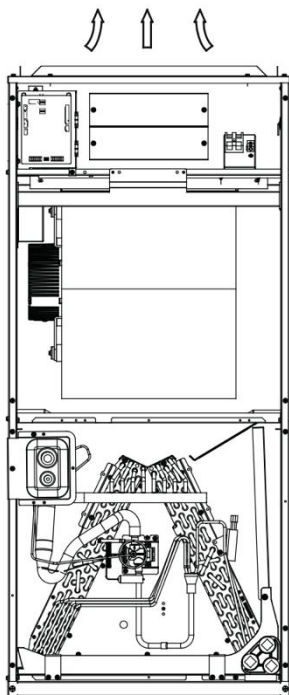

Upflow

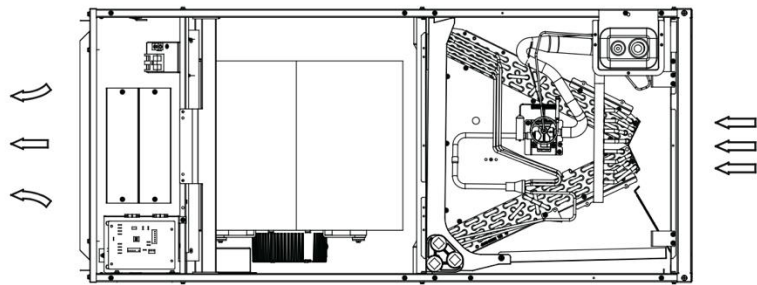

horizontal left

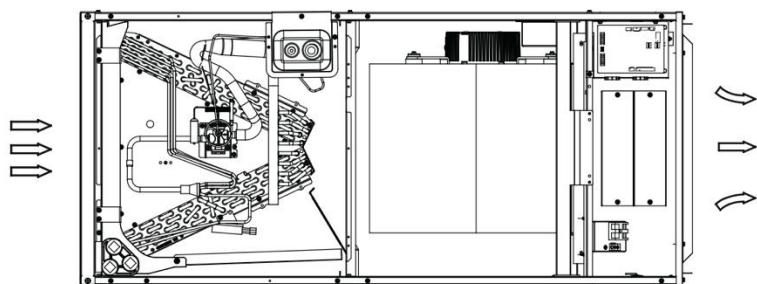

horizontal right

NOTE

For the downward air outlet installation, you need to purchase service parts from the dealer and have a qualified personnel to install them.

Indication of the position of each temperature sensor on the evaporator:

24-36K model

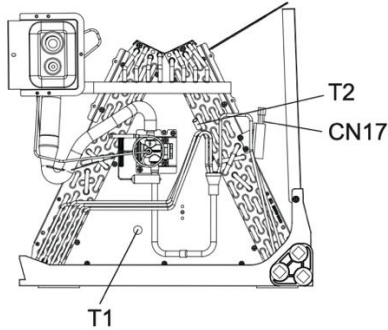

48-60K model

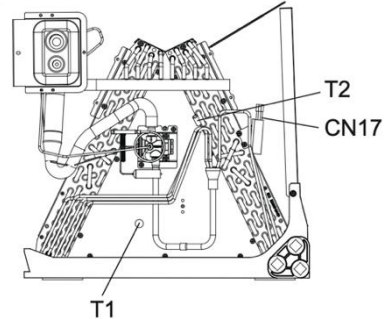

INSTRUCTION

For the horizontal installation (Left), how to disassemble and reinstall the evaporator assembly.

- 1. Remove the fixed plate of the filter, then take the filter off.
- 2. Remove the upper cover assembly.

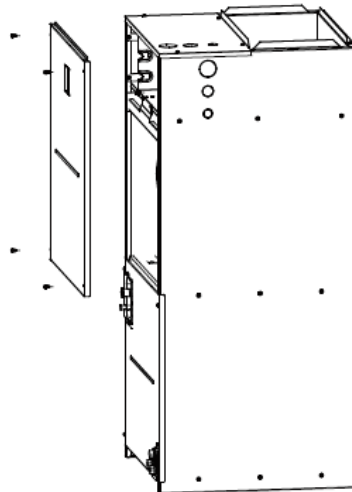
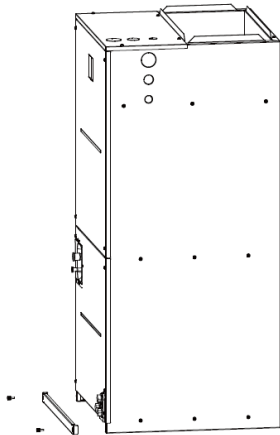

- 3. Remove evaporator cover plate.

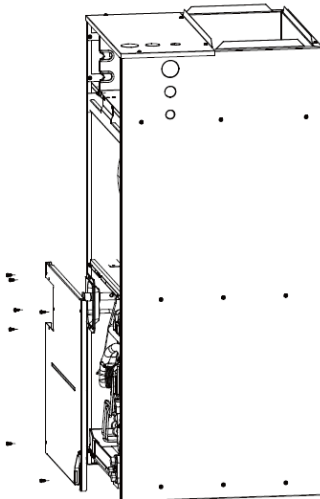

- 4. Remove the plug of the CN17 refrigerant sensor and the plug of the CN18 temperature sensing bag.

CN17: Refrigerant Sensor
CN18: Temperature Sensor

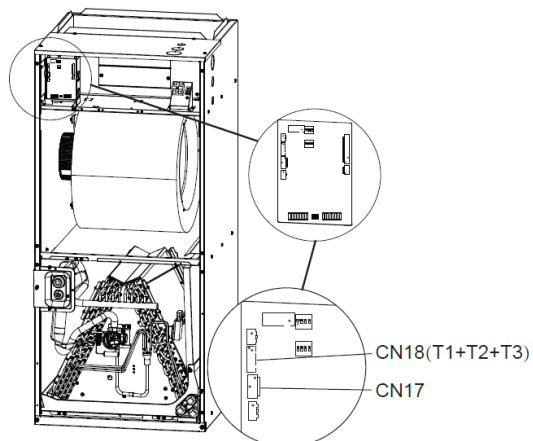

5. Remove CN17、CN18 wire ties.

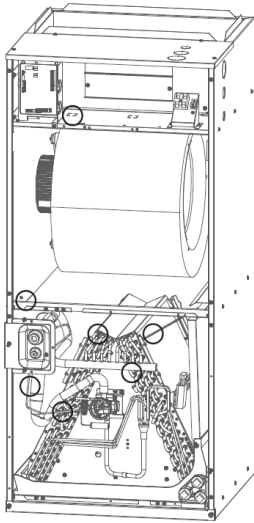

6. Take out the evaporator and drain pan and rotate 180°.

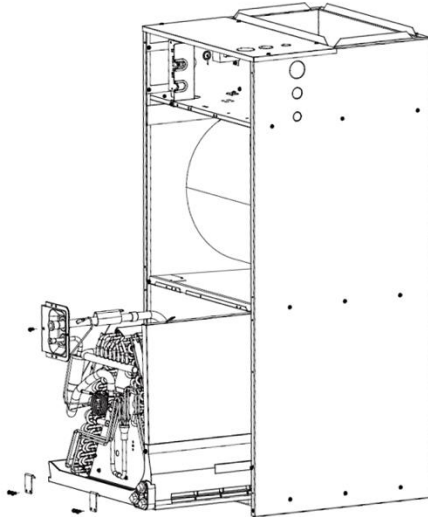

7. Reinstall the evaporator.

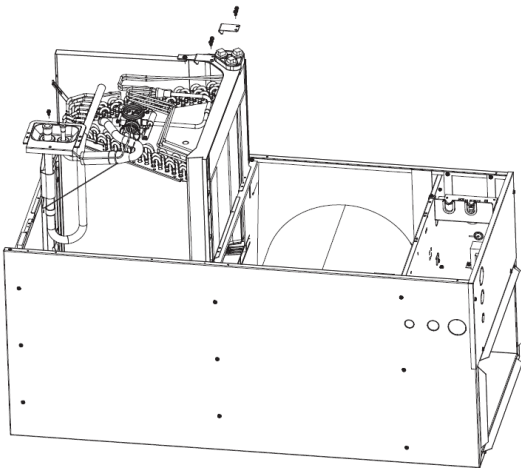

8. Reinstall CN17 and CN18 plug and tie up the sensor wires.

NOTICE

The wire body needs to pass through the wire groove from the water receiving tray and be stuck on the hook of the water receiving tray.

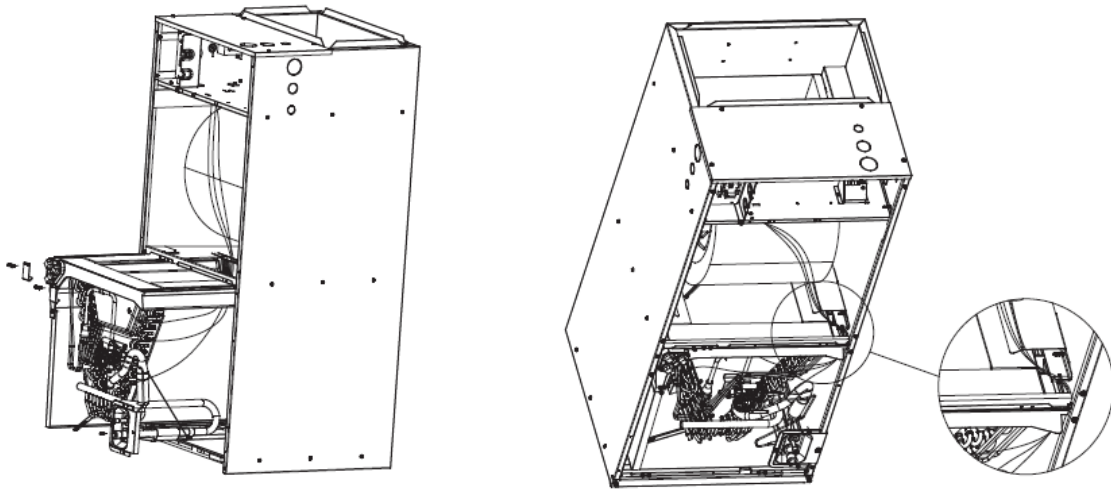

9. Reinstall the drain pan fixed plate and auxiliary support plate.

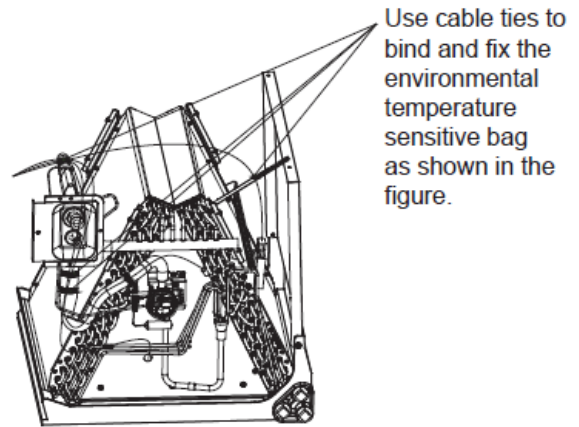
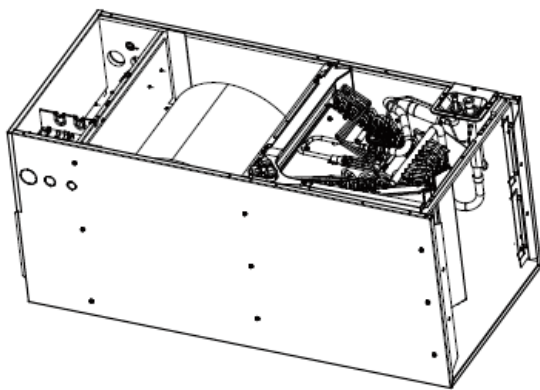

10. Reinstall evaporator cover plate.

11. Reinstall the upper cover assembly.

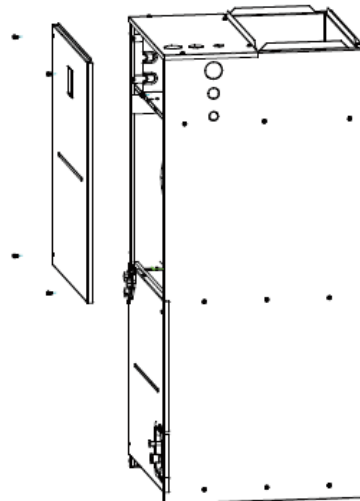
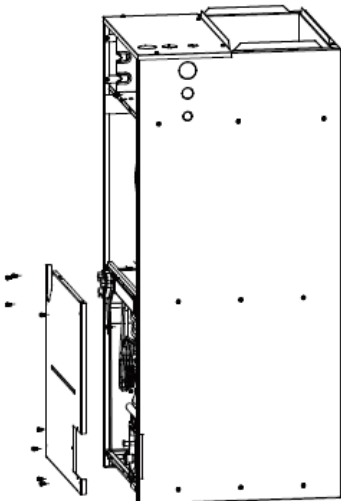

12 Reinstall the filter and filter plate.

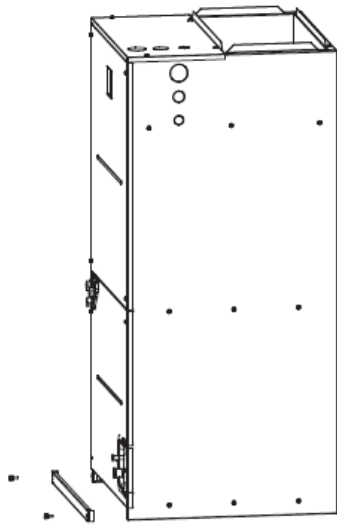

13. Connect the wire according to the wiring diagram.

2.2.2 Outdoor unit installation

Exposure to a corrosive environment may shorten the life of the equipment, corrode metal parts, and/or negatively affect unit performance. Corrosive elements include, but are not limited to: sodium chloride, sodium hydroxide, sodium sulfate, and other compounds commonly found in ocean water, sulfur, chlorine, fluorine, fertilizers, and various chemical contaminants from industry/manufacturing plants. If installed in areas which may be exposed to corrosive environments, special attention should be given to the equipment placement and maintenance.

- Lawn sprinklers/waste water should not spray directly on the unit cabinet for prolonged periods.
- In coastal areas: locate the unit on the side of the building away from water.

Cold Climate Considerations

Precautions must be taken for units being installed in areas where snow accumulation and prolonged below-freezing temperatures occur. Elevate unit as per local climate and code requirements. This additional height will allow drainage of snow and ice melted during defrost cycle to flow out smoothly prior to its refreezing. A snow drift barrier should be installed around the unit to prevent a build-up of snow on the unit sides.

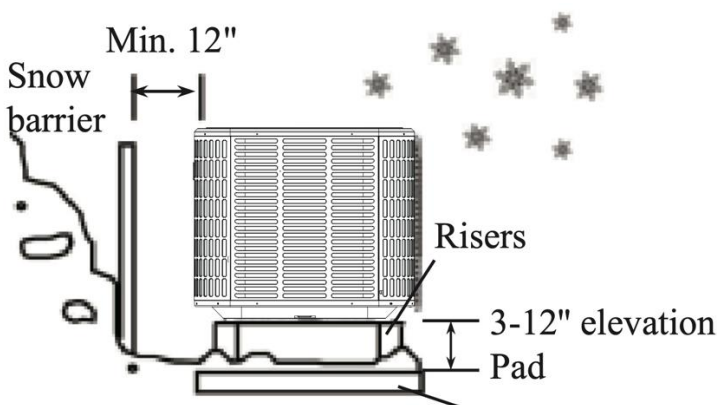

Consideration to prevent refreezing

When mounting the unit on a roof, be sure the roof will support the unit's weight obtained from nameplate.

Properly selected isolation is recommended to prevent sound or vibration transmission to the building structure.

2.2.3 Piping connection

2.2.3.1 Notice and requirement for piping connection

Refrigerant pipe Limits

Use only the pipe size indicated in below table and determine required pipe length. If the suction pipe set is greater than 50 feet, do not use a larger suction pipe than recommended.

The pipe sizes and maximum length

Capacity Model	Liquid Line	Suction Line	Minimum Piping Length	Maximum line length	Maximum Elevation Difference(ft)
	Dimensions in inches				
24K	3/8 Std.	3/4 Std.	15	98	49
36K	3/8 Std.	3/4 Std.	15	98	49
48K	3/8 Std.	7/8 Std.	15	164	82
60K	3/8 Std.	7/8 Std.	15	164	82

Std.: Standard pipe size.

• Maximum line length = ___ feet. • Maximum elevation difference = ___ feet.

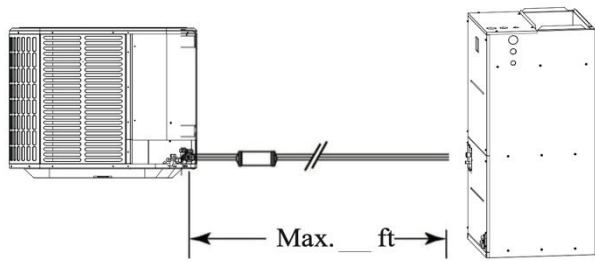

Line length limit

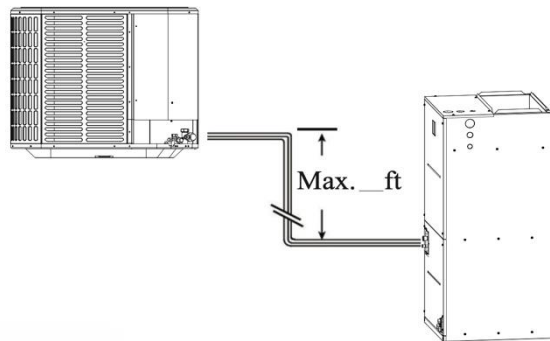
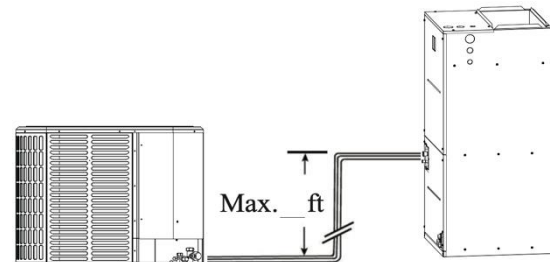

Elevation difference limit

NOTE

The suction pipe must always be insulated.

DO NOT allow the suction pipe and liquid pipe contact directly (metal to metal).

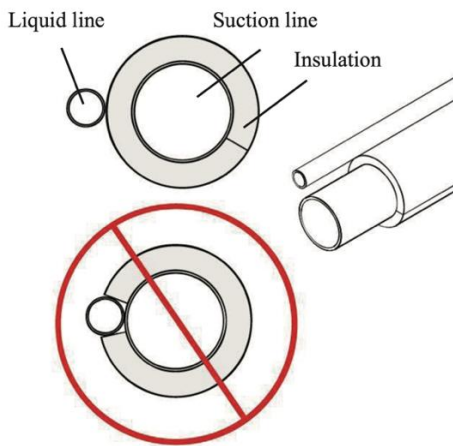

Use the existing Refrigerant pipes

CAUTION

If using the existing refrigerant lines, make sure that all joints are brazed, not soldered.

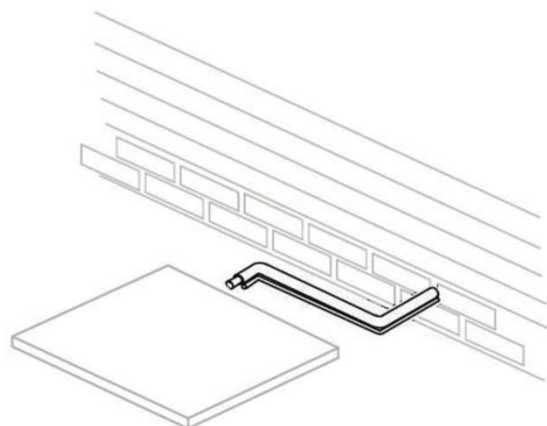

IMPORTANT

The manufacturer recommends installing only approved matched indoor and outdoor systems. All of the manufacturer's split systems are AHRI rated with TXV indoor units. Some of the benefits of installing approved matched indoor and outdoor split systems are maximum efficiency, optimum performance and the best overall system reliability.

Refrigerant pipes ROUTING

Comply with National, State, and Local Codes when isolating pipe sets from joists, rafters, walls, or other structural elements. Take precautions to prevent noise within the building structure due to vibration transmission from the refrigerant pipes.

For Example:

- Use isolation type hangers when the refrigerant pipes have to be fastened to floor joists or other framing.
- Isolation hangers should also be used when refrigerant pipes traverse stud spaces or enclosed ceilings.
- Where the refrigerant pipes pass through a wall or sill, it should be insulated and isolated.
- Isolate the pipes from all ductwork.
- Minimize the number of 90° turns.

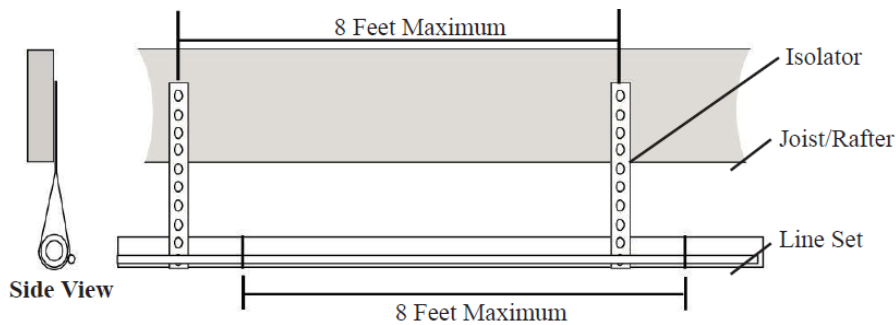

Secure suction pipe from joists using isolators every 8 ft. secure liquid pipe directly to insulated suction pipe using tape, wire, or other appropriate method every 8 ft.

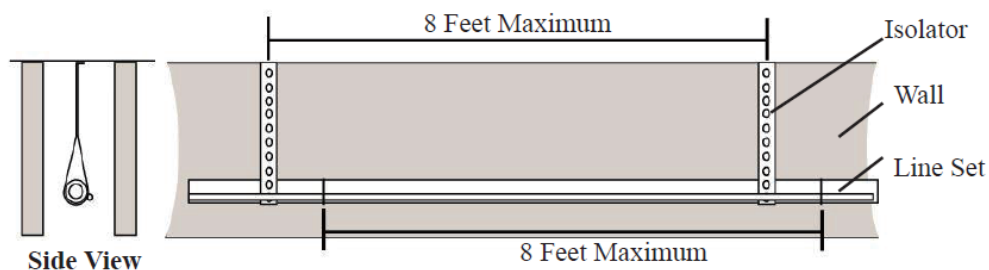

Secure suction pipe using isolators every 8 ft. secure liquid pipe directly to insulated suction pipe using tape, wire, or other appropriate method every 8 ft.

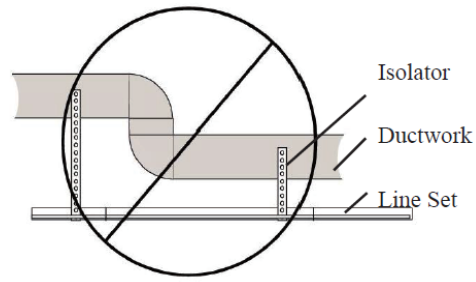
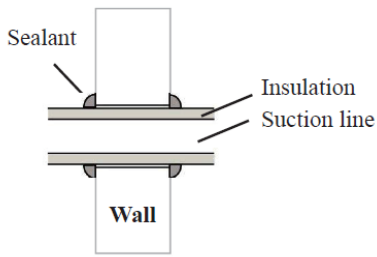

Leak check and evacuation must be done before opening the service valves.
 The gas service valve must be opened BEFORE opening the Liquid Service Valve!

1. Remove service valve cap.
2. Fully insert hex wrench into the stem and counterclockwise until valve stem just touches the rolled edge (approximately five turns.)
3. Replace and tighten the valve stem cap to prevent leaks. Additional 1/6turn may be required.

Repeat 1 to 3 for Liquid Service Valve.

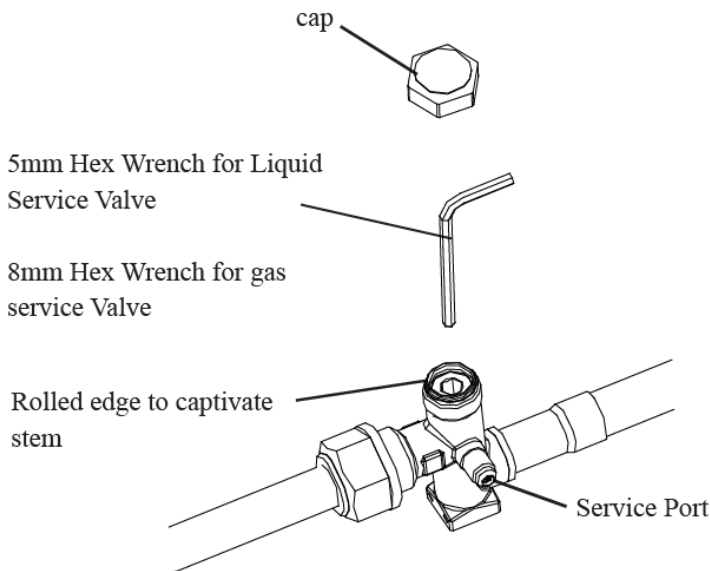

! WARNING

Extreme caution should be exercised when opening the Liquid Service Valve. Turn counterclockwise until the valve stem just touches the rolled edge. No torque is required. Failure to follow this will result in abrupt release of system charge and may lead to personal injury and /or property damage.

2.2.3.2 Pipe flaring

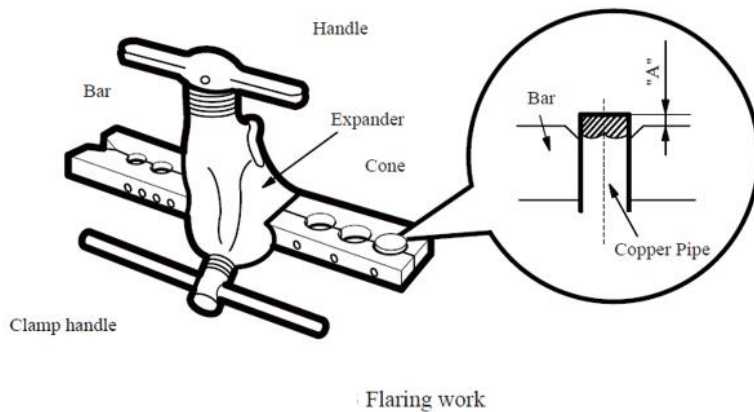

Main cause for gas leakage is due to defect in pipe flaring.
Carry out correct flaring work in the following procedure.

A. Cut the pipes and the cable.

- 1) Use the piping kit accessory or the pipes purchased locally.
- 2) Measure the distance between the indoor and the outdoor unit.
- 3) Cut the pipes a little longer than measured distance.
- 4) Cut the cable 1.5m longer than the pipe length.

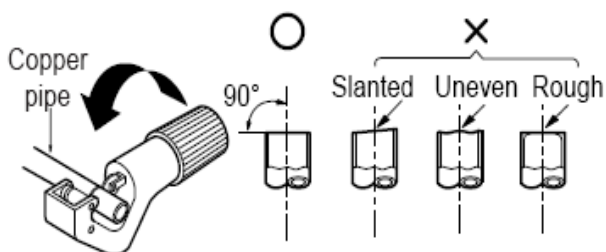

B. Burrs removal

- 1) Completely remove all burrs from the cut cross section of pipe/tube.
- 2) Put the end of the copper tube/pipe in a downward direction as you remove burrs in order to avoid dropping burrs into the tubing.

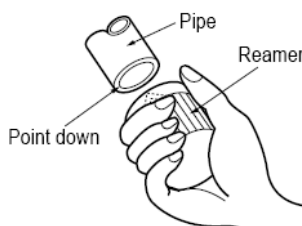

C. Flaring work

- Carry out flaring work using flaring tool as shown below.

Outside diameter	A
Inch	Inch
3/8"	0.03"~0.04"
3/4"	0.02"~0.03"
7/8"	0.02"~0.03"

Firmly hold copper pipe in a die in the dimension shown in the table above.

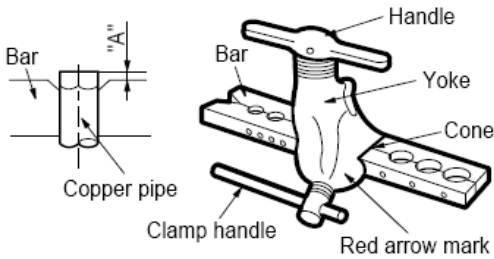

D. Check

- 1) Compare the flared work with figure below.
- 2) If flare is noted to be defective, cut off the flared section and do flaring work again.

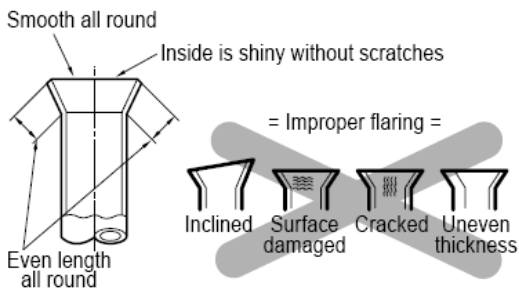

2.2.3.3 Connect pipes of indoor and outdoor units

Pipe Connection

You should first connect the low-pressure pipe, then the high-pressure pipe.

1. Align the center of the two pipes that you will connect.
2. Tighten the flare nut as tightly as possible by hand.
3. Using a wrench, grip the nut on the unit tubing.

NOTE

Use two wrench to connect the pipe with indoor/outdoor pipes to avoid the copper pipe cracking.

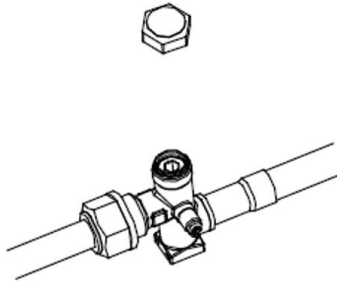

Pipe connection

4. While firmly gripping the nut, use a torque wrench to tighten the flare nut according to the torque values.

Torque Values

Connecting Pipe Size	Torque Values (lbf*in)
3/8"	327-372
3/4"	620-664
7/8"	690-735

5. Insert the connecting pipe of the indoor unit into the reamer transfer nozzle flaring of the outdoor unit, and braze the connecting port.

CAUTION

- Ensure to wrap insulation around the piping. Direct contact with the bare piping may result in burns or frostbite.
- Make sure the pipe is properly connected. Over tightening may damage the bell mouth and under tightening may lead to leakage.

6. Insulate all the piping, including the gas valve of the outdoor unit.

7. Open the stop valves of the outdoor unit to start the flow of the refrigerant between the indoor and outdoor unit.

CAUTION

- Check to make sure there is no refrigerant leak after completing the installation work. If there is a refrigerant leak, ventilate the area immediately and evacuate the system (refer to the Air Evacuation section of this manual).

2.2.4 Vacuum and leak detection

2.2.4.1 Vacuum pumping

Do not open the service valves until the leak check and evacuation are complete.

1. Evacuate until the micron gauge reads no higher than 350 microns, then close the valve to the vacuum pump.
2. Evacuation is complete if the micron gauge does not rise above 500 microns in one minute.

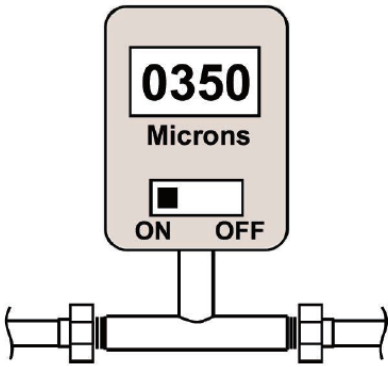

2.2.4.2 Leak detection methods

Leak check is required for the brazed pipe connections.

1. Pressurize the brazed refrigerant pipes and indoor coil to at least 150 PSIG with nitrogen (N₂).
2. Check for leaks by using soapy bubbles at each brazed point.

150PSIG

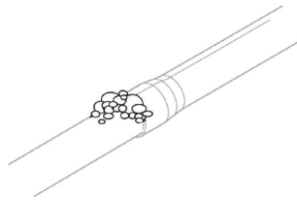

Charge dry nitrogen to the system

Leak check

2.2.5 Refrigerant adding

Refrigerant Charge

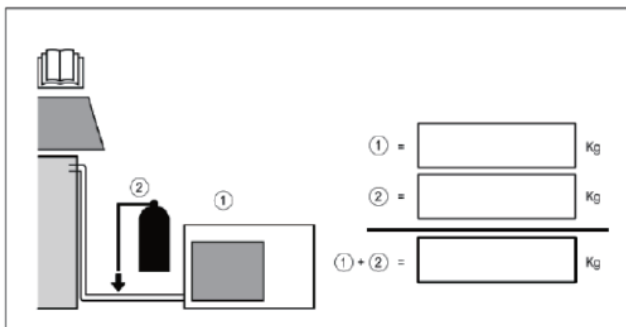

①=precharged part(See the nameplate above)

②=added during installation(See the manual)

①+②= Total Amount

Pipe Length and Additional Refrigerant

Model	24K	36K	48K	60K
Length of pipe with standard charge(ft)	25	25	25	25
Refrigerant capacity of standard charge(lbs)	3.97	5.51	7.72	7.72
The longest pipe length(ft)	100	100	165	165
Additional refrigerant charge(lbs/ft)	0.0134	0.0134	0.0134	0.0134
Max.diff. in level between indoor and outdoor unit(ft)	50	50	50	50

Total Refrigerant Capacity (lb)

Model	Category	LFL(lbs/ft ³)	h0(ft)	Pipe Length(ft)				
				25	49	66	98	164
24K	R32	0.0191	7.2	3.97	4.3	4.52	4.95	/
36K				5.51	5.84	6.06	6.49	/
48K				7.72	8.05	8.27	8.7	9.59
60K				7.72	8.05	8.27	8.7	9.59

Minimum Room Area (ft²)

Model	Category	LFL(lbs/ft ³)	h0(ft)	Pipe Length(ft)				
				25	49	66	98	164
24K	R32	0.0191	7.2	11.8	12.8	13.5	15.7	/
36K				19.4	21.8	23.5	26.9	/
48K				38.1	41.4	43.7	48.4	58.7
60K				38.1	41.4	43.7	48.4	58.7

2.2.6 Installation of drain pipe

2.2.6.1 Indoor side drain pipe

1. When the air handler is installed **vertically**, please block the upper drainage hole with a cover. The lower right of the drainage hole is connected with the drainage pipe(②), and the lower left of the drainage hole is connected with the overflow pipe(①) that should be exposed to the air; If the pipe ① is draining, which means the pipe ② is blocked. Contact maintenance personnel as soon as possible.

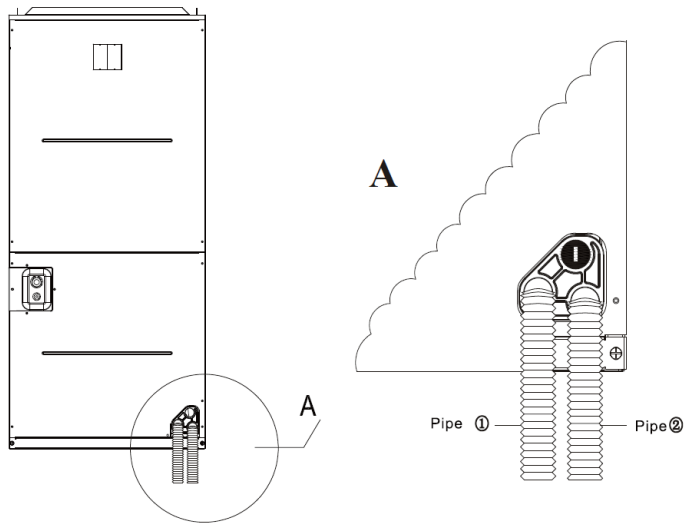

Vertical

2. When installing the air handler **lying down**, the upper drainage hole is covered, the lower left of the drainage hole is connected with the drainage pipe(②), the lower right of the drainage hole is connected with the overflow pipe (①) that should be exposed to the air.
 If the pipe ① is draining, which means the pipe ② is blocked. Contact maintenance personnel as soon as possible.

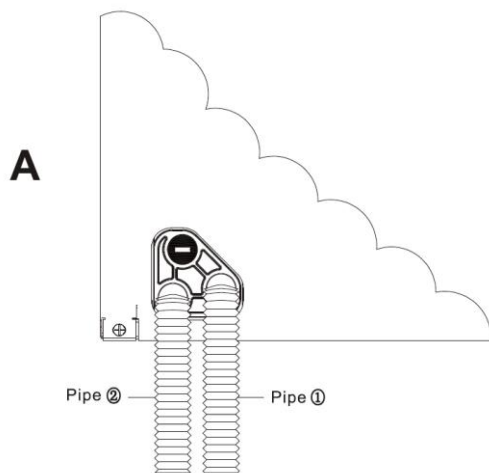
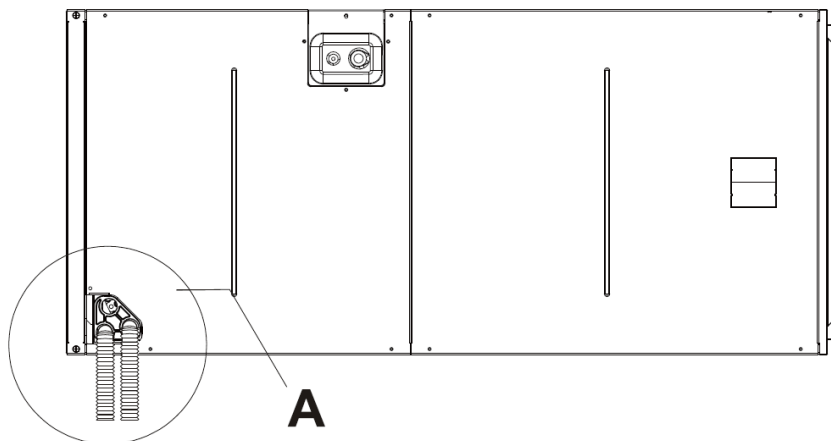

Horizontal right

Installation in an unconditioned space

There are two pairs of coil rails in the air handler for default and counter flow application. If the air handler is installed in an unconditioned space, the two unused coil rails should be removed to minimize air handler surface sweating.

The coil rails can be easily removed by taking off the 6 mounting screws from both sides of the cabinet.

2.2.7 Installation of the duct

2.2.7.1 Dimensions of the supply air outlet / return air inlet

Field ductwork must comply with the National Fire Protection Association NFPA 90A, NFPA 90B and any applicable local ordinance.

WARNING

Do not, under any circumstances, connect return ductwork to any other heat producing device such as fireplace insert, stove, etc. Unauthorized use of such devices may result in fire, carbon monoxide poisoning, explosion, personal injury or property damage.

Sheet metal ductwork run in unconditioned spaces must be insulated and covered with a vapor barrier. Fibrous ductwork may be used if constructed and installed in accordance with SMACNA Construction Standard on Fibrous Glass Ducts. Ductwork must comply with National Fire Protection Association as tested by U/L Standard 181 for Class I Air Ducts. Check local codes for requirements on ductwork and insulation.

- Duct system must be designed within the range of external static pressure the unit is designed to operate against. It is important that the system airflow be adequate. Make sure supply and return ductwork, grilles, special filters, accessories, etc. are accounted for in total flow resistance. Refer to the airflow performance table in this manual.
- Supply plenum is attached to the 3/4" duct flanges supplied with the unit. Attach flanges around the blower outlet.
- Secure the supply and return ductwork to the unit flanges, using proper fasteners for the type of duct used and tape the duct-to-unit joint as required to prevent air leaks.

IMPORTANT

If an elbow is included in the plenum close to the unit, it must not be smaller than the dimensions of the supply duct flange on the unit.

The front flange on the return duct connected to the blower casing must not be screwed into the area where the power wiring is located. Drills or sharp screw points can damage insulation on wires located inside unit.

2.2.7.2 Return air method

Connect the return air pipe at the return air inlet of the indoor unit through the duct to realize air return through air inflow by the blower.

The distance between the mounted indoor unit should meet the specifications illustrated in the following diagram.

Horizontal installations

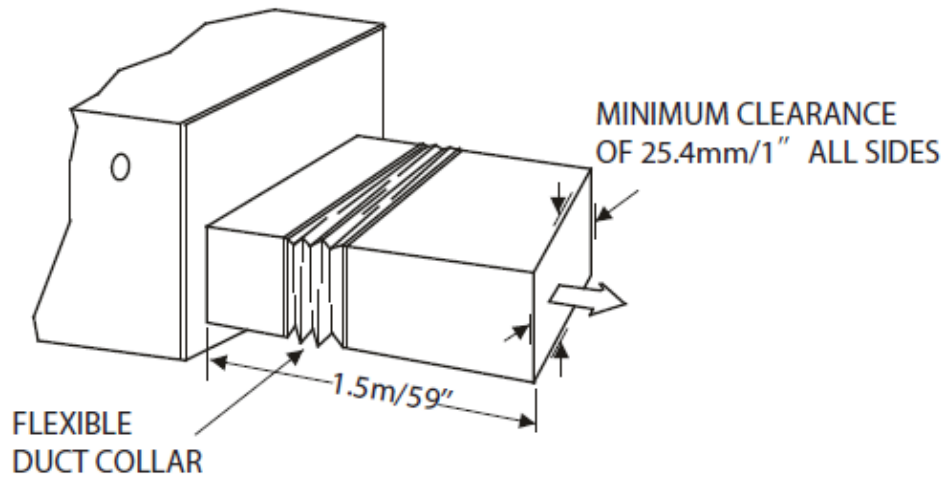

Vertical up installations

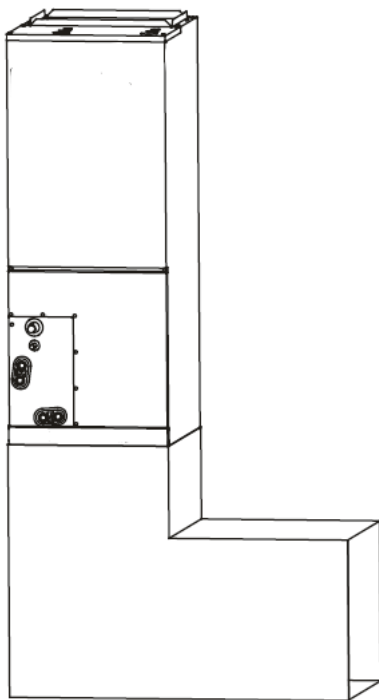

The size of the air outlet is based on A and 10-5/16", and that of the return air inlet is based on D and W. A bracket should be made, with a recommended width of 20mm. (For A, 10-5/16", D and W, please check the picture below)

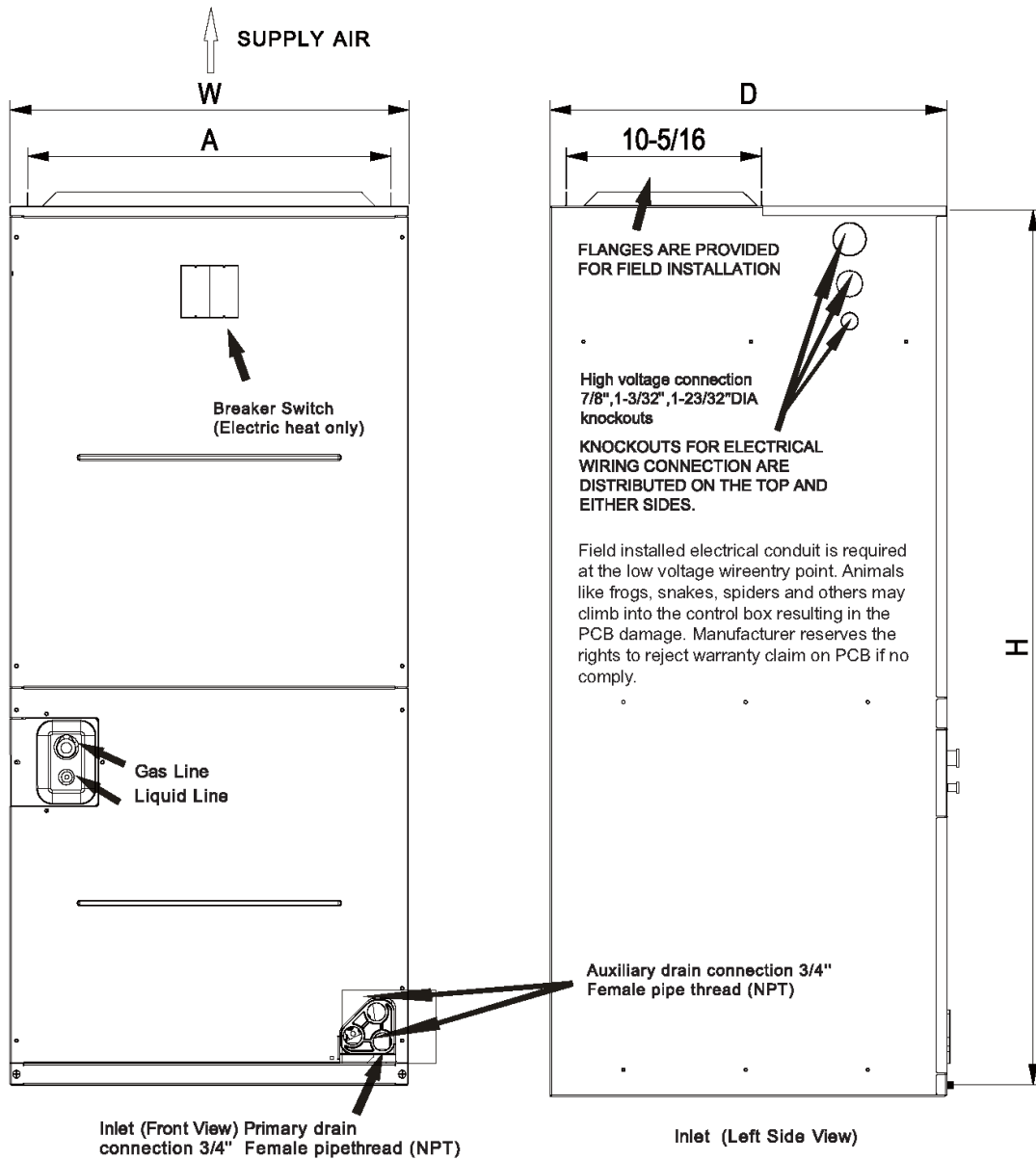

2.3 Electrical installation

2.3.1 Requirement and notice of electrical installation

2.3.1.1. Indoor unit

Dedicated distribution device and wire for air conditioner

Min. circuit ampacity of air conditioner(A)	Minimum wire cross-sectional area(mm ²)	Specification of socket or switch(A)	Fuse specification(A)
≤ 8	0.75	15	15
>8 and ≤ 10	1.0	15	15
>10 and ≤ 15	1.5	20	25
>15 and ≤ 24	2.5	25	40
>24 and ≤ 28	4.0	35	45
>28 and ≤ 32	6.0	40	55

NOTE:

The table above for reference only, the installation shall meet the requirement of local law and regulation.

2.3.1.2. Outdoor unit

2.3.1.2.1. Low voltage wire requirement

Define the maximum length of low voltage wiring from condensing unit to indoor unit and thermostat. Field installed electrical conduit is required at the low voltage wire entry point. Animals like frogs, snakes, spiders and others may climb into the control box resulting in the PCB damage. Manufacturer reserves the rights to reject warranty claim on PCB if no comply.

Table 11-1 Low voltage control wiring requirement

CONTROL WIRING	
Wire Size	Max. Wire Length
18 AWG	164ft

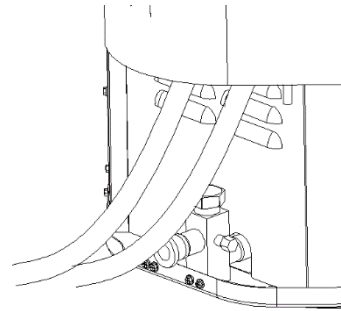

2.3.1.2.2. Low voltage hook-up diagram

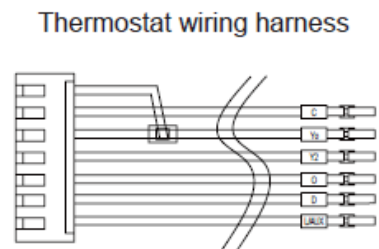
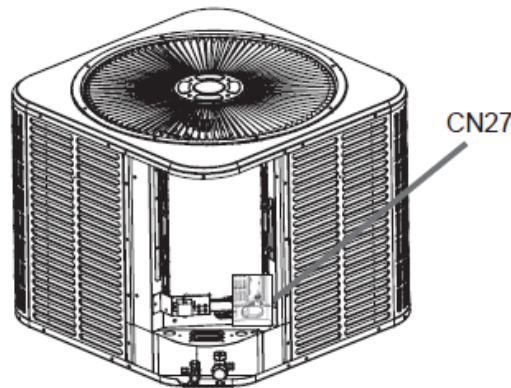
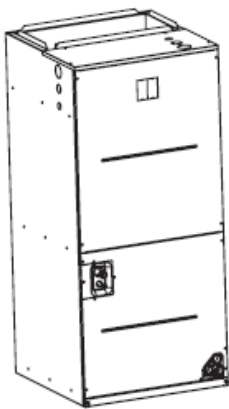

Low voltage control wiring connection

Class 2 low voltage control wiring should not be run in conduit with main power wiring and must be separated from power wiring, unless class 1 wire of proper voltage rating is used.

Low voltage control wiring should be color-coded 18 AWG.

Refer to wiring diagrams attached to indoor and outdoor sections to be connected.

Make sure separation of control wiring and power wiring has been maintained.

2.3.1.2.3. High voltage power supply

WARNING

During installation, testing, servicing, and troubleshooting of this product, it may be necessary to work

with live electrical components.

Failure to follow all electrical safety precautions when exposed to live electrical components could result in death or serious injury.

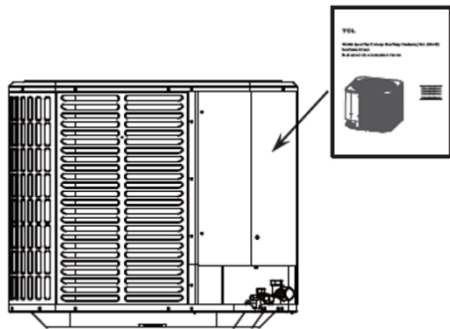

Read the warning label

The high voltage power supply must be in agreement with the equipment nameplate. Power wiring should comply with National, State and Local codes.

Follow instructions on unit wiring diagram located on the inside of the control box cover.

Power Supply			
Model	Voltage	MCA	Breaker
24K	280/230V-1Ph-60Hz	16A	25A
36K		24A	40A
48K		35A	60A
60K		35A	60A

2.3.1.2.4. High voltage disconnect switch

Install a separated disconnect switch at the condensing unit. Field provided flexible electrical conduit must be used for high voltage wiring.

In order to get full warranty coverage on the compressor, it's mandatory to install a surge protector to prevent the unit from damaging caused by abnormal electrical spikes.

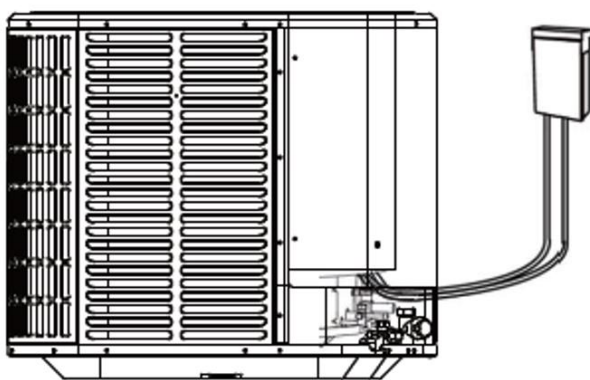

Install an independent switch

2.3.1.2.5. Grounding

Grounding the outdoor unit according to National, State, and Local code requirements.

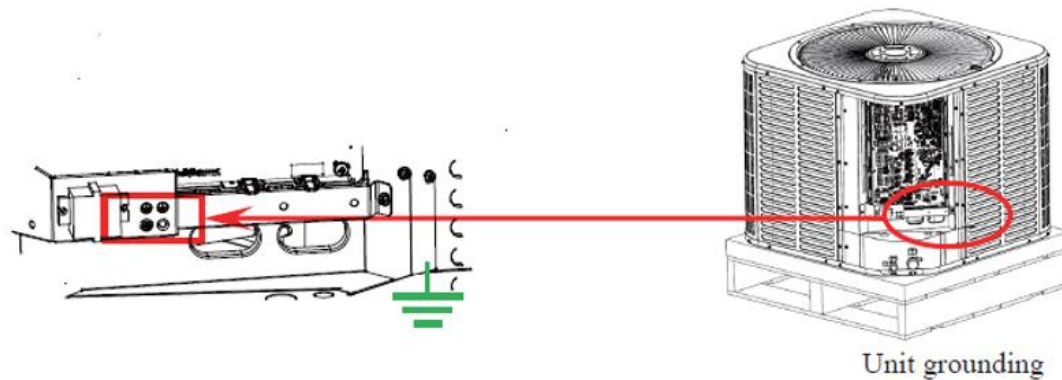

2.3.2 Electrical parameters

2.3.2.1 Wire specification and fuse capacity

Field wiring must comply with the National Electric Code (C.E.C. in Canada) and any applicable local ordinance.

WARNING

Disconnect all power to unit before installing or servicing. More than one disconnect switch may be required to de-energize the equipment. Hazardous voltage can cause severe personal injury or death. Ground the unit according to National, State, and Local code requirements.

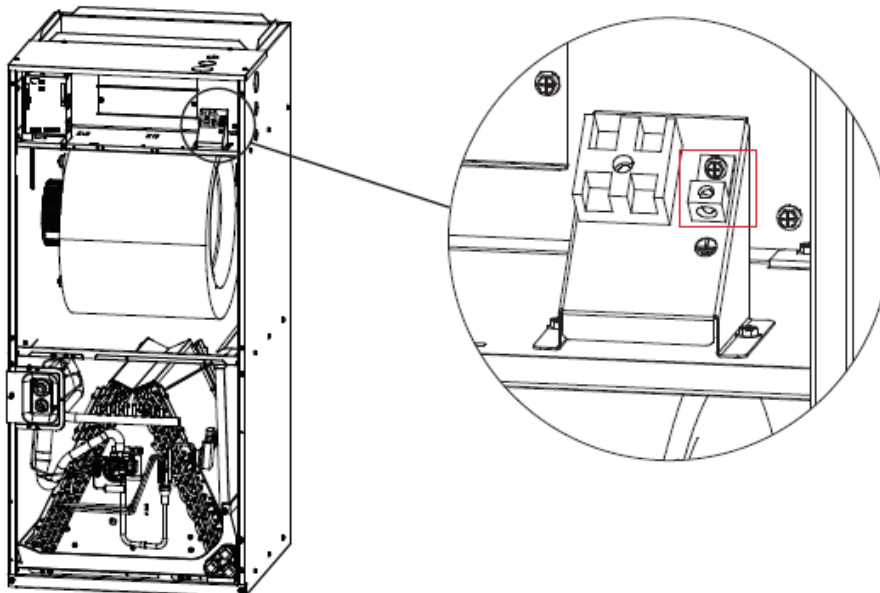

Minimum cross-sectional area of power and signal cables

Wiring material ampacities	AWG
4	22
7	20
10	18
13	16

18	14
25	12
30	10
40	8
55	6
70	4

The ampacities shown apply to appliance wiring materials with insulation rated not less than 90°C (194°F).

Supply circuit power wiring must be copper conductors.

It is important that proper electrical power is available for connection to the unit model being installed. Refer to the unit nameplate, wiring diagram and electrical data in the installation instructions.

- If required, install a branch circuit disconnect of adequate size, located within sight of, and readily accessible to the unit.
- When the electric heater is installed, units may be equipped with one or two 30~60 Amp circuit breakers. These breakers protect the internal wiring in the event of a short circuit and serve as a disconnect. Circuit breakers installed within the unit do not provide over-current protection of the supply wiring and therefore may be sized larger than the branch circuit protection.
- Supply circuit power wiring must be 167 °F minimum copper conductors at least. Refer to electrical data in this section for ampacity, wire size and circuit protector requirements. Supply circuit protective devices may be either fuses or “HACR” type circuit breakers.

2.3.3 Connection of power cord and communication cord

1. The power cable is selected based on the above wire size and local safety regulation (single-phase power supply);

2. 485 communication—The communication line (for indoor and outdoor units, wire controller)

The wired controller and overhead butted wire for the wire controller, 485 communication line for indoor and outdoor units are required.

Installation Diagram

Connect the wire from the master control board of the indoor unit to a connecting cable. Then connect the other side of the connecting cable to the wired control.

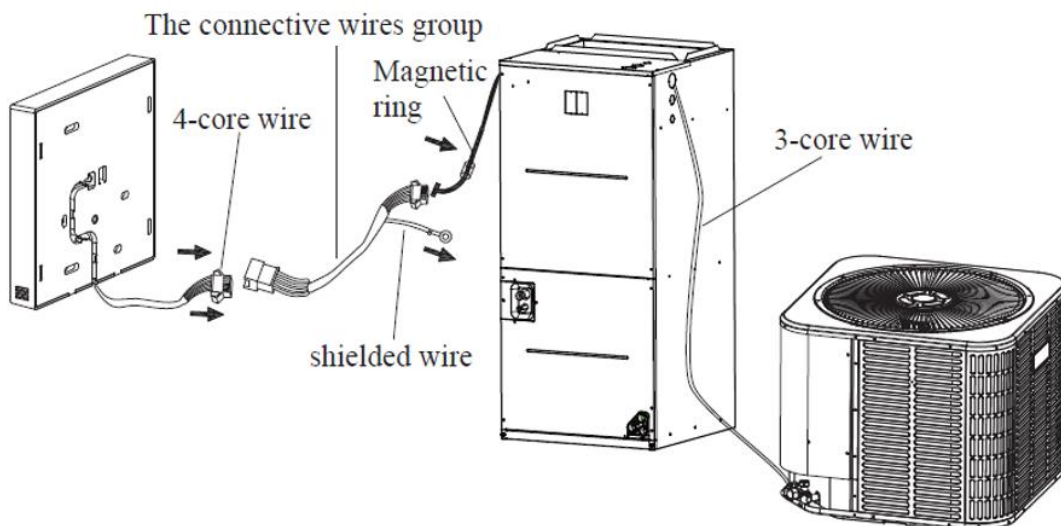

NOTE

Be sure to reserve a length of the connecting wire for periodic maintenance.
 There is a connection lug at the end of shielded wire, the connection lug should be properly grounded.

3. The 24V communication (thermostat)

Class 2 low voltage control wiring should not be run in conduit with main power wiring and must be separated from power wiring, unless class 1 wire of proper voltage rating is used.

Low voltage control wiring should be color-coded 18 AWG.

Refer to wiring diagrams attached to indoor and outdoor sections to be connected.

Make sure separation of control wiring and power wiring has been maintained.

2 Stage, 2 Step, Heating Pump

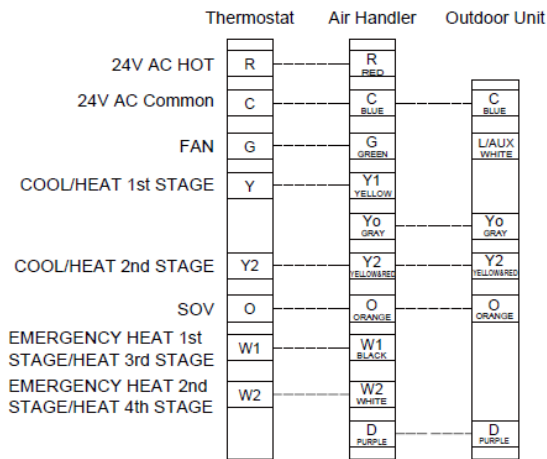

2 Stage, 2 Step, Cooling Only

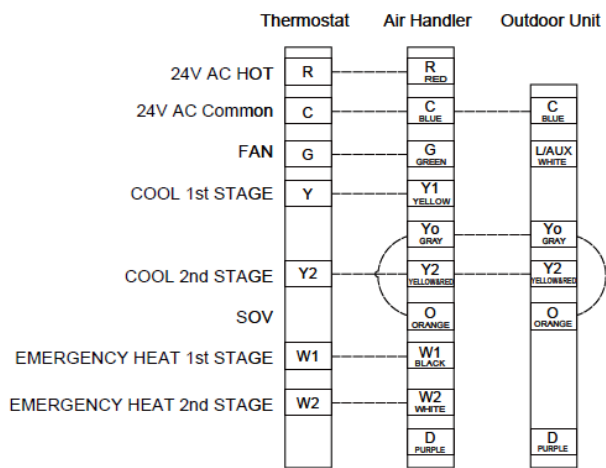

Single Stage, Heating Pump

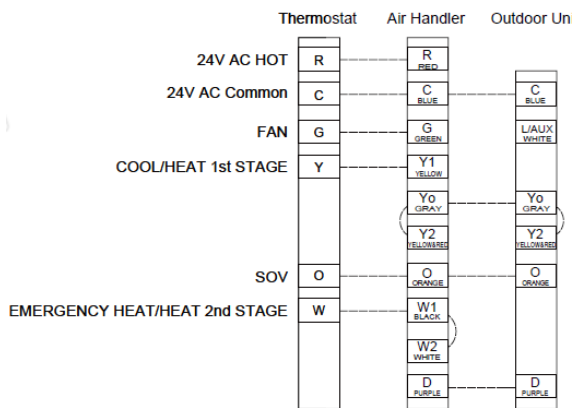

Single Stage, Cooling Only

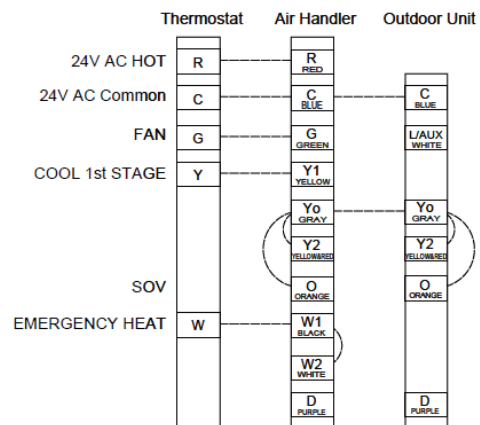

Thermostat wiring harness

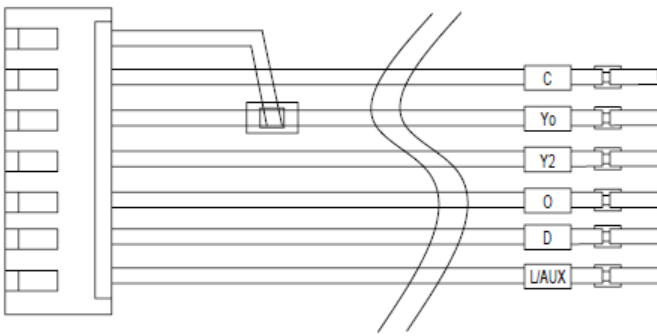

2.4 Check after installation

After confirming proper wiring, start the unit for operation. If any problem arises, check the fault code.

WARNING

Electrical safety Precautions.

- 1) Cut off the power supply of air conditioner before checking and maintenance.
- 2) The air conditioner must apply specialized circuit and prohibit share the same circuit with other appliances.
- 3) The air conditioner should be installed in suitable location and ensure the power plug is touchable.
- 4) Make sure each wiring terminal is connected firmly during installation and maintenance.
- 5) Have the unit adequately grounded. The grounding wire can't be used for other purposes.
- 6) Must apply protective accessories such as protective boards, cable-cross loop and wire clip.
- 7) The live wire, neutral wire and grounding wire of power supply must be corresponding to the live wire, neutral wire and grounding wire of the air conditioner.
- 8) The power cord and power connection wires can't be pressed by hard objects.
- 9) If power cord or connection wire is broken, it must be replaced by qualified person.
- 10) If the power cord or connection wire is not long enough, please get the specialized power cord or connection wire from the manufacture or distributor. Prohibit prolong the wire by yourself.
- 11) For the air conditioner without plug, an air switch must be installed in the circuit. The air switch should be all-pole parting and the contact parting distance should be more then 3mm.
- 12) Make sure all wires and pipes are connected properly and the valves are opened before energizing.
- 13) Check if there is electric leakage on the unit body. If yes, please eliminate the electric leakage.
- 14) Replace the fuse with a new one of the same specification if it is burnt down, don't replace it with a cooper wire or conducting wire.
- 15) If the unit is to be installed in a humid place, the circuit breaker must be installed.

2.5 Test running

Blinking definition (For 24V communication only).

The LED lights 200ms **ON** and then 200ms **OFF**, defined as a LED light flashing.

LED light color	LED light status	Failure
-----------------	------------------	---------

Green light	Turn off	Standby mode
Green light	stay lit	In operation
Green light	beat 1	Anti-cold air operation. (blinks once, OFF for 1s)
Green light	beat 2	Auxiliary electric heater works. (blinks twice, OFF for 1s)
Green light	beat 3	For unit commodity inspection only. (blink s3 times, OFF for 1s)
Green light	beat 4	For self-check. (blinks 4 times, OFF for 1s)
Red light	Turn off	Normal operation.
Red light	stay lit	Refrigerant leak protection
Red light	beat 1	The communication of the refrigerant sensor abnormal. (blinks once, and then OFF for 1s).
Red light	beat 2	Internal fan fault. (blinks twice, OFF for 1s)
Red light	beat 3	Indoor coil temperature sensor fault (blinks 3 times, OFF for 1s)
Red light	beat 4	Indoor supply temperature sensor fault (blinks four times, and then disappears for 1s)
Red light	beat 5	EEPROM fault (blinks 5 times, OFF for 1s)
Red light	beat6	Indoor/Outdoor 485 Communication failure (blinking six times, OFF for 1s)
Red light	beat 7	Controller 485 Communication failure (blinking 7 times, OFF for 1s)

NOTE

1. The Red (LED1) and Green (LED2) lights are located on the indoor unit PCB.
2. For 485 Communication, it will show the failure codes on the wired Controller.

3. Maintenance instruction manual

1. Inspections before maintenance.

(1) Inspection of maintenance environment

- There should be **no leaked refrigerant** in the room before operation.
- It is only allowed to operate in a room which meets the area requirement on the nameplate.
- It is necessary to make the room keep a continuous **ventilation** state at the time of maintenance.
- The room in the maintenance should be free from **fire or welding, smoking, drying oven** or any other goods temperature higher than **396°C (R32)** which easily produces fire.
- During the maintenance, it is necessary to ensure that any person's any **mobile phone** or any **electronic product** with radiation in the room is powered off.
- The maintenance area should be equipped with a drying powder or carbon dioxide **fire extinguisher** and that such fire extinguisher can work.

(2) Inspection of maintenance equipment

- Check the maintenance equipment is applicable to the refrigerant or not and it is only allowed to use the **professional equipment** recommended by the air conditioner manufacturer.
- Check the **refrigerant leak detector** whether has been calibrated. The set maximum alarm concentration of the refrigerant leak detector should not exceed 25% of the lower explosion limit (LEL), the refrigerant leak detector must be working during maintenance.

2. Inspection of air conditioner

- It is necessary to ensure that the air conditioner is in reliable **ground connection** before maintenance.
- Make sure **powered supply** to air conditioner is off. Before maintenance, it is necessary to cut off the power and discharge the capacitor power which used in the air conditioner. If it is a must to need the power supply during the maintenance, it is necessary to do ongoing leak detection at the most dangerous position/point in order to avoid potential danger.
- Check the warning labels on the air conditioner whether are in good condition. It is necessary to replace the damaged or smeared warning labels.

3. Leak inspection before maintenance

Before maintenance, use the **leak detector** or **concentration detector** (pump-type) recommended by the corresponding air conditioner manufacturer to check the air conditioner leak or not.

WARNING

If leak may exist, it is necessary to move all the fire out from the site or extinguish fire and then immediately shut off the air conditioner. Meanwhile, it is necessary to make sure well-ventilated.

4. Safety principles during the maintenance

- At the time of maintenance, it is necessary to ensure well-**ventilation** on the site.
- It is prohibited to use fire including welding, smoking or other purposes. It is prohibited to use mobile phones.
- At the time of maintenance, if the relative humidity is lower than 40%, it is necessary to wear **anti-static** clothing and gloves.

- If the combustible refrigerant is found leaking during the maintenance, it is a must to immediately take forced ventilation and plug up the leak source.

If the product is damaged to the extent that it is a must to open the refrigerating system for maintenance, it is a must to carry the product back to the maintenance station for maintenance. (It is prohibited to weld the refrigerant pipe and do other operations on the user's site.)

- It is necessary to return the air conditioner to its initial state if it is necessary to provide visiting service again due to lacking spare part during the maintenance. Moreover, it is a must to ensure that the refrigerating system is in secure **ground connection**.
- If it is necessary to provide visiting service with a refrigerant cylinder, the volume of refrigerant filled in such refrigerant cylinder should not exceed the stipulated value. When such cylinder is stored in a vehicle or placed on the installation or maintenance site, it is necessary to place it vertically and securely and keep it away from any place where there is any heat source, combustion source, radiation source or electrical equipment.

5. Requirements for the site of maintenance-station

- The maintenance location should be **well-ventilated**, with leveled ground and not in a basement.
- The maintenance should be divided into welding and non-welding areas both of which should be labeled clearly. There should be a certain safety distance between the two areas. The maintenance location should be equipped with ventilating and air-exhausting equipment to prevent the refrigerant gas from aggregating.
- It is necessary to provide some relevant instruments such as combustible refrigerant **leak detector** and have a leak detecting instrument management system. It is necessary to confirm that the leak detector can work normally before maintenance.
- The main **power switch** should be set outside the maintenance location and equipped with protective (explosion-proof) devices.
- It is necessary to provide firefighting devices such as dry powder or carbon dioxide fire **extinguisher** appropriate for extinguishing the electrical fire and keep such firefighting devices in a usable condition.
- Temporary wires and sockets are prohibited on the maintenance location.

6. Requirements for fill the refrigerants

- It is necessary to use **nitrogen** to clear the cyclic system before operating the refrigerating system and vacuumize the outdoor unit for 30 minutes at least.
- It is necessary to ensure that there is no cross contamination among different refrigerants when the refrigerant filling device is used. The total length including the refrigerant pipeline should be as short as possible in order to reduce the residual refrigerant inside such pipeline.
- It is necessary to vertically place the refrigerant storage tanks.
- It is necessary to ensure that the refrigerating system is in **ground** connection before the refrigerant is filled.
- When filling the refrigerant, it is necessary to fill corresponding type and volume of refrigerant as per the requirements on the product nameplate and overfilling is prohibited.
- It is necessary to seal the system in a safe sealing way after maintaining the refrigerating system.
- It is necessary to ensure that the maintenance will not damage or reduce the safety protection grade of the original system.

7. In-maintenance welding

- It is necessary to ensure that the maintenance location is well-**ventilated**.
- Before welding the outdoor unit, it is a must to confirm that the refrigerating system has been drained and the system has been cleaned and ensure that there has been no refrigerant in the outdoor unit.
- It is necessary to close the stop valve of the outdoor unit when using a welding gun to do the maintenance work such as cutting and welding.

8. Maintenance of electrical components

- It is necessary to use a special **leak detector** to check whether the maintained electrical parts location have the leak refrigerant.
- It is not allowed to refit, remove or cancel any component with the safety protection function after finishing the maintenance process.
- When maintaining the sealed parts, it is necessary to turn off the power of air conditioner before opening the sealing cover. When power supply is needed, it is necessary to do the ongoing leak detection at the most dangerous position in order to prevent potential danger.
- It is necessary to specially note that the maintenance of electrical components will not affect the replacement of protective cover.
- In order to ensure that the sealing function is not damaged after maintenance or the sealing material will not lose the effect of preventing the combustible gas leak due to ageing. So the substitute components should meet the requirements recommended by the air conditioner manufacturer.

WARNING

Before doing the trial operation after finishing the maintenance, it is a must to use a practical leak detector to inspect the leakage and reliability of ground connection in order to ensure that no refrigerant leakage and reliable ground connection.

The refrigerant storage tanks should be separately placed in a well-ventilated place at the temperature ranging from -10°C to 50°C and label them with warning labels.

9. Emergency Accident Handling

A maintenance station should establish emergency handling plans. It is necessary to take appropriate precautionary measures in work. For example, it is prohibited to enter the location with any kindling material and it is prohibited to wear clothing or shoes which easily produce static.

Handling suggestions when a large amount of combustible refrigerant leaks:

- It is necessary to immediately operate the ventilating equipment while cutting off other power supply and evacuating the affected personnel urgently from the location.
- It is necessary to inform near residents of evacuating for over 20 meters from the location, make an alarm call, set the emergency area and prohibit irrelevant personnel and vehicles from approaching.
- The professional firefighters should wear anti-static clothing to handle the emergency on the site and cut off the source of leak.

It is necessary to use nitrogen for blowing the site, especially the low-lying positions, clear away the residual combustible refrigerant gas from any area nearby and surrounding the leak point and use a handheld detector for detection and not clear the alarm until the concentration of refrigerant is zero.

3.1 Control

3.1.1 Operation mode

3.1.1.1 Cooling mode

1. When the indoor unit receives a cold start signal from the temperature controller or wire controller, it will start the blower, and run in the corresponding wind speed according to the Y1/Y2 signal of the temperature controller or the set wind speed of the wire controller, when the indoor unit receives a cold shutdown signal from the temperature controller or wire controller, the fan will stop running after a short delay.

2. When the outdoor unit receives a cold start signal from the temperature controller or wire controller, it will start the blower and compressor, and adjust the speed of the outdoor blower and compressor automatically according to the Y1/Y2 signal of the temperature controller or the set temperature difference of the wire controller, when the outdoor unit receives a cold shutdown signal from the temperature controller or wire controller, it will stop running after a short delay.

3.1.1.2 Heating mode

1. When the indoor unit receives a heat start signal from the temperature controller or wire controller, it will start the blower, and run in the corresponding wind speed according to the Y1/Y2 signal of the temperature controller or the set wind speed of the wire controller, when the indoor unit receives a heat shutdown signal from the temperature controller or wire controller, the fan will stop running after a short delay.

2. When the outdoor unit receives a heat start signal from the temperature controller or wire controller, it will start the blower and compressor, and adjust the speed of the outdoor blower and compressor automatically according to the Y1/Y2 signal of the temperature controller or the set temperature difference of the wire controller, it will stop running after a short delay, the outdoor unit may enter the defrosting mode during heating. At this point, the internal and external blowers may stop running, the four-way valve will switch to the cooling mode, and the compressor will enter the defrosting mode for defrosting at the corresponding speed.

3.1.1.3 Emergency heat mode

While the indoor unit is provided with electric auxiliary heating, if it receives an emergency heating mode signal from the temperature controller or wire controller, the blower will start running. The electric auxiliary heater will start automatically according to the W1/W2 signal of the temperature controller or the set temperature difference of the wire controller. In the emergency heating mode, the indoor blower will maintain a high wind speed and the outdoor unit will not run. When receiving a shutdown signal from the thermostat or wire controller, the electric auxiliary heater will shut down and the fan will stop running after a short delay.

3.1.2 Control mode

3.1.2.1 Based control

3.1.2.1.1 Compressor control

Under different modes, the compressor can only be stopped after running for some time (special cases exclude). This is to protect the compressor from frequent start or stop. Once the compressor is stopped, it must not be restarted right away, please wait for a few minutes.

3.1.2.1.2 EXV control

When the unit is first started, the electronic expansion valve will reset control. During the process, the expansion valve will produce rattling sound. When cooling mode is turned on, the valve will be opened at the max step before the compressor starts. When heating mode is turned on, the valve will be opened at a certain step before the compressor starts.

3.1.2.1.3 Indoor fan control

The indoor fan can run at the highest level 7 and the lowest level 1. When a 24V control thermostat is used, the indoor blower may only operate at up to two speeds. When the RS485 communication wire controller is used, the indoor blower can operate at seven speeds according to the wind speed set by the wire controller. In the heating mode, the indoor blower may stop running when the outdoor unit is defrosting.

3.1.2.1.4 Outdoor fan control

The outdoor fan can run at the highest level 5 and the lowest level 1. By controlling the speed of outdoor fan, the unit can achieve cooling at low temperature. In fan mode, outdoor fan will not work.

3.1.2.1.5 Four-way valve control

The four-way valve of the outdoor unit is in a power-off state during cooling mode. When switching to heating, it will change its direction, resulting in a change in the refrigerant circulation path and realizing the heating function. In the heating mode, if the outdoor unit starts defrosting, the four-way valve will be powered off again during defrosting, resulting in a change in the refrigerant circulation path and realizing the defrosting effect.

3.1.2.2 Special control

3.1.2.2.1 Oil return control

When the outdoor unit is operating at a low frequency for a long time, to ensure the reliability of the unit, the compressor speed will be increased automatically during the set time period for oil return operation, and the digital display will show **4**. At this point, the operating mode of the unit remains unchanged, and the compressor speed, outdoor blower speed, and electronic expansion valve openness will be adjusted to the corresponding parameters of the oil return mode. After 5 minutes, the unit will exit from the oil return mode and the original operating state will be restored.

3.1.2.2.2 Defrost control

When the system is in the heating mode, the detected temperature of the outdoor coil will be lower than the set value due to frosting, and the unit will enter the defrosting mode. The digital display of the outdoor unit will show **5**, the outdoor blower will stop, the four-way valve will switch to the cooling state, and the compressor will run at the defrosting speed for defrosting. After continuous running for some time, if the outdoor tube temperature exceeds the set value for exiting from defrosting, the unit will exit from the defrosting mode and resume operation in the original mode.

3.1.2.2.3 Warm-up control for outdoor unit winding

To avoid the migration of refrigerant into the compressor at low temperatures, which may lead to poor oil return or difficult startup of the unit, the unit is provided with the winding preheating function. When the outer ring temperature is lower and the compressor is in the stop state, the controller will apply a certain current value to the compressor winding coil to warm it up and heat the compressor oil sump. It is advised

to keep warming up the unit for 2 hours before starting the unit when the outer temperature is too low.

3.1.2.2.4 Forced start

In special circumstances where it is impossible to start the unit normally through the temperature controller or wire controller, or when refrigerant recovery is required, the unit can be started through the forced operation function.

When the outdoor unit is in the standby mode, hold down **KEY4 for 3 seconds** and then release it. The unit will enter the forced **cooling mode**, and the digital display of the outdoor unit will show **7**;

When the outdoor unit is in the standby mode, hold down **KEY4 for 6 seconds** and then release it. The unit will enter the forced **heating mode**, and the digital display of the outdoor unit will show **8**.

3.1.2.3 Protection control

3.1.2.3.1 High pressure protection control

System will enable high pressure protection control if the high-pressure switch is detected open for continuously a little time. Under high pressure protection, system will be shut down.

When high pressure protection occurs for the first time, system will restore operation if the high-pressure switch is detected to be reclosed for continuously a little time. When high pressure protection occurs for the second time in a certain time period, system will not restore operation. You need to manually turn off the unit and clear the error before restarting up the unit. (If high pressure protection occurs frequently, please send for professional personnel to repair it.)

3.1.2.3.2 Low pressure protection control

System will enable low pressure protection control if the low-pressure switch is detected open for continuously a little time. Under low pressure protection, system will be shut down.

When low pressure protection occurs, system will restore operation if the low-pressure switch is detected to be reclosed within a few minutes after shutdown. If low pressure protection occurs for several times in a period of time, system will not restore operation automatically. You need to manually turn off the unit before restarting up the unit.

3.1.2.3.3 Refrigerant leakage protection

When refrigerant leakage occurs in the indoor unit, the refrigerant leakage sensor will trigger an alarm, and the outdoor unit will stop running. The indoor unit's wind speed will be adjusted to the maximum wind speed automatically to dilute the refrigerant concentration.

When a refrigerant leakage alarm occurs, a professional must be notified to confirm the leakage problem on site, and the unit can be powered on again after troubleshooting only.

3.1.3 Functions

(when RS485 wire controller is required) (refer to the instruction manual for wire controller)

Function:

Mode: Auto - Cool - Dry - Fan -Heat - Emergency Heat

Fan speed: Mute /Low/Med-low/Med/Med-high/High speed/Turbo/Auto

Timer ON/OFF

Temp setting

Weekly timer

24-hour System

12-hour System

Auto-restart (on some models)

Child Lock

LCD display

Clock

Panel function (on some models)

3.2 troubleshooting

3.2.1 Wiring diagrams

Wiring diagram of indoor unit

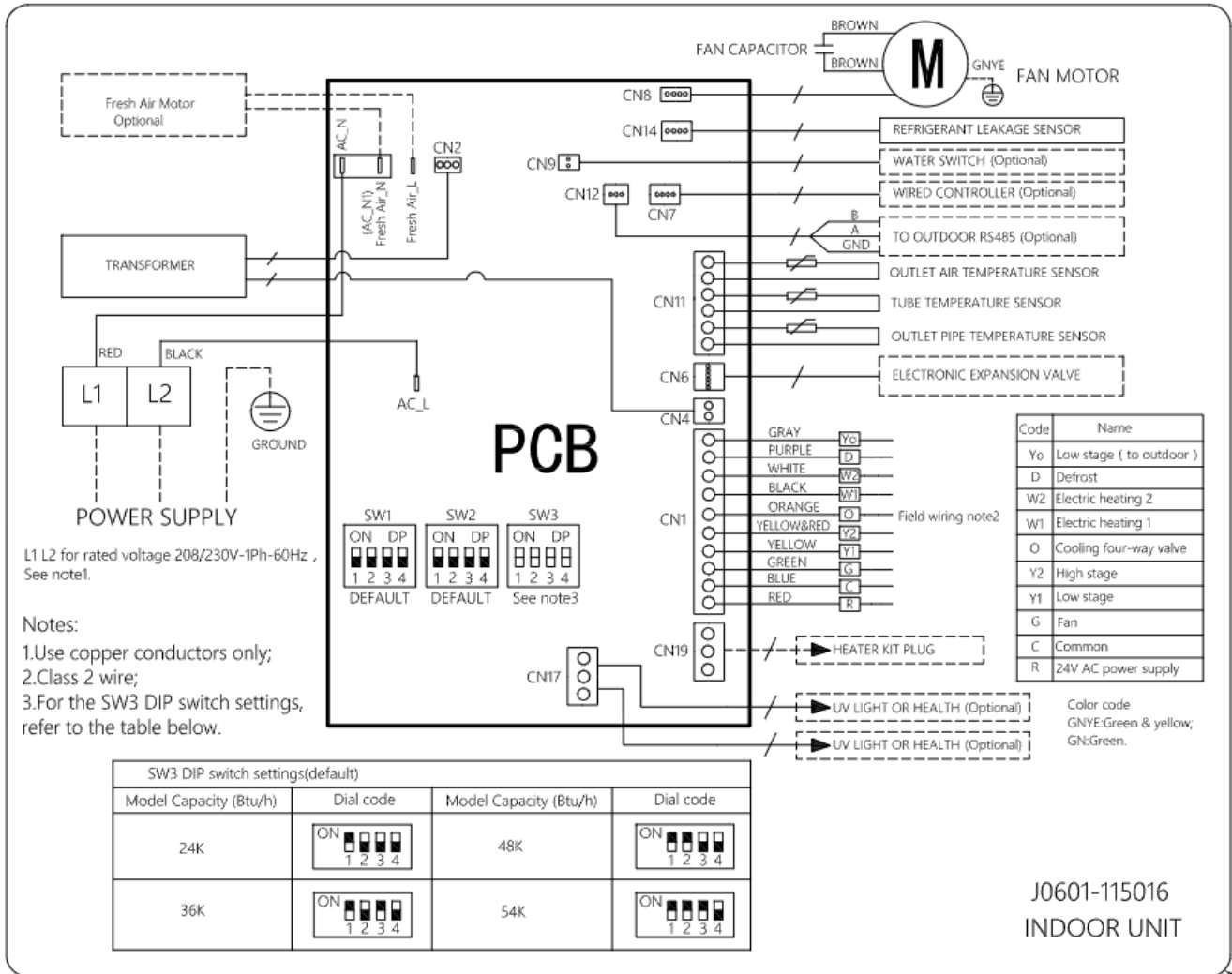

Wiring diagram of outdoor unit

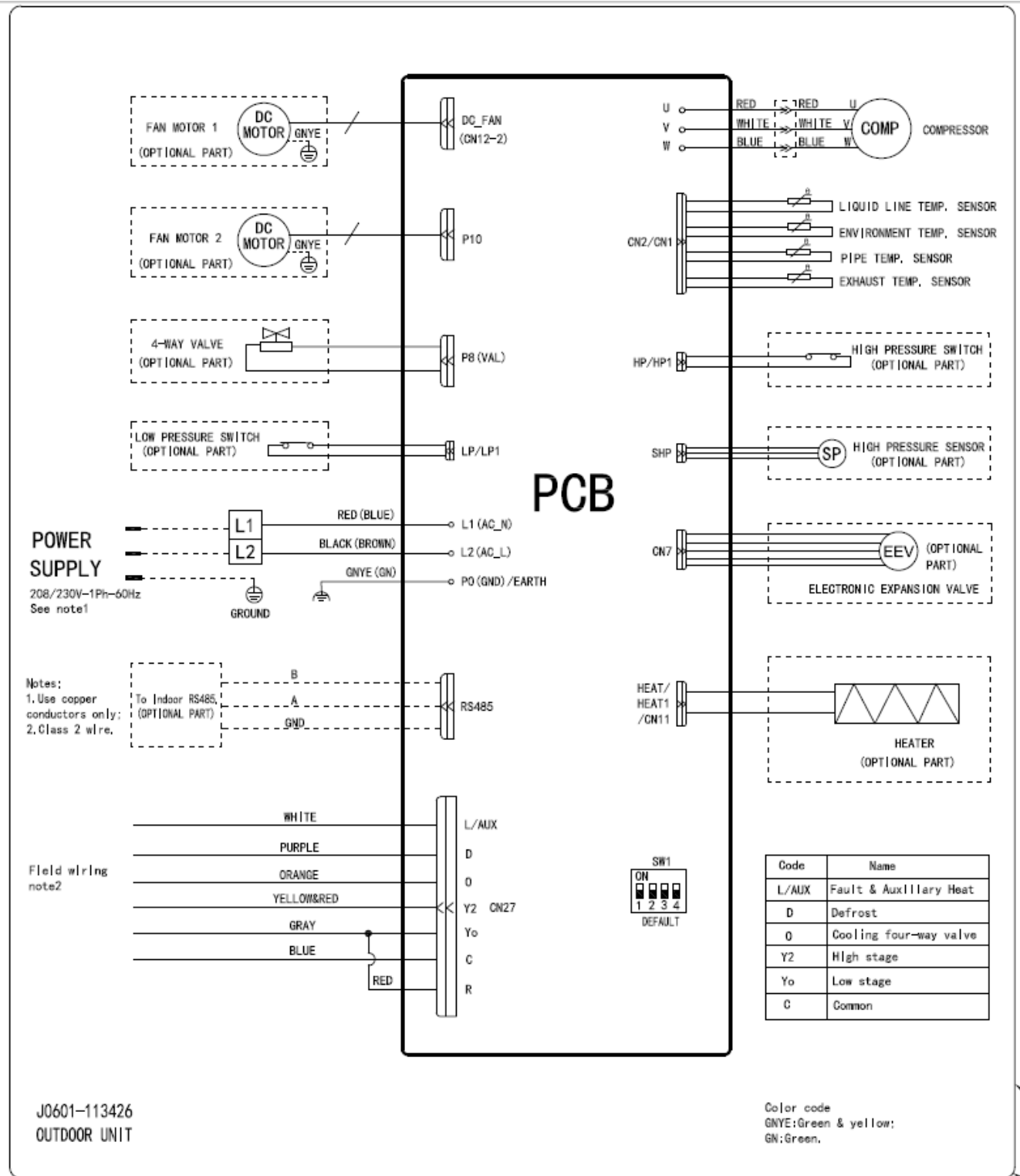

3.2.2 PCB Layout

Electric control of indoor unit

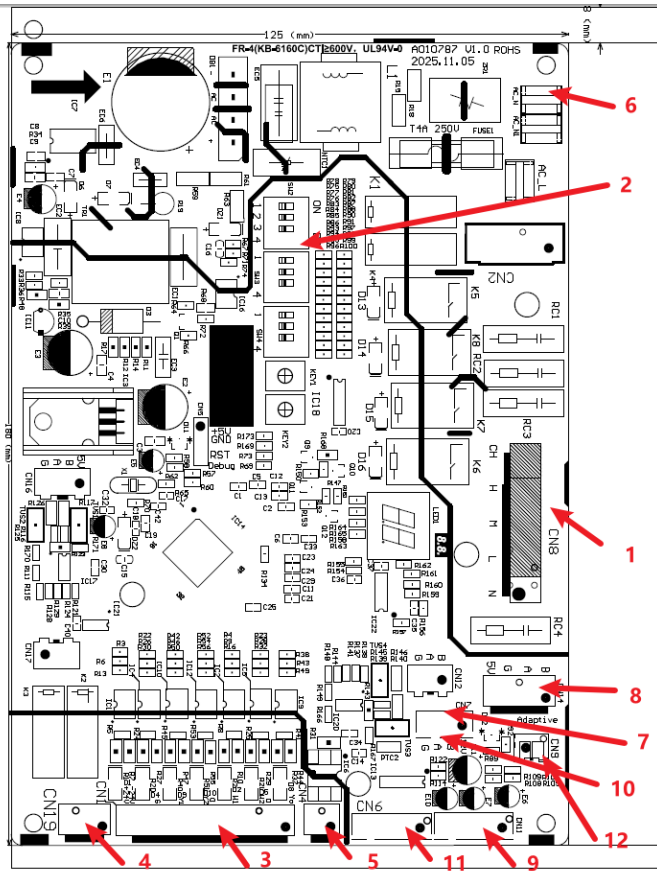

1	Fan motor
2	Dual In-line package switch 123
3	24V AC Thermostat
4	Heater
5	AC 24V power supply
6	AC208/230 60Hz power supply
7	Wired remote controller
8	Refrigerant sensor
9	Temperature sensor
10	Outdoor 485
11	EEV
12	Water switch

Electric control of outdoor unit

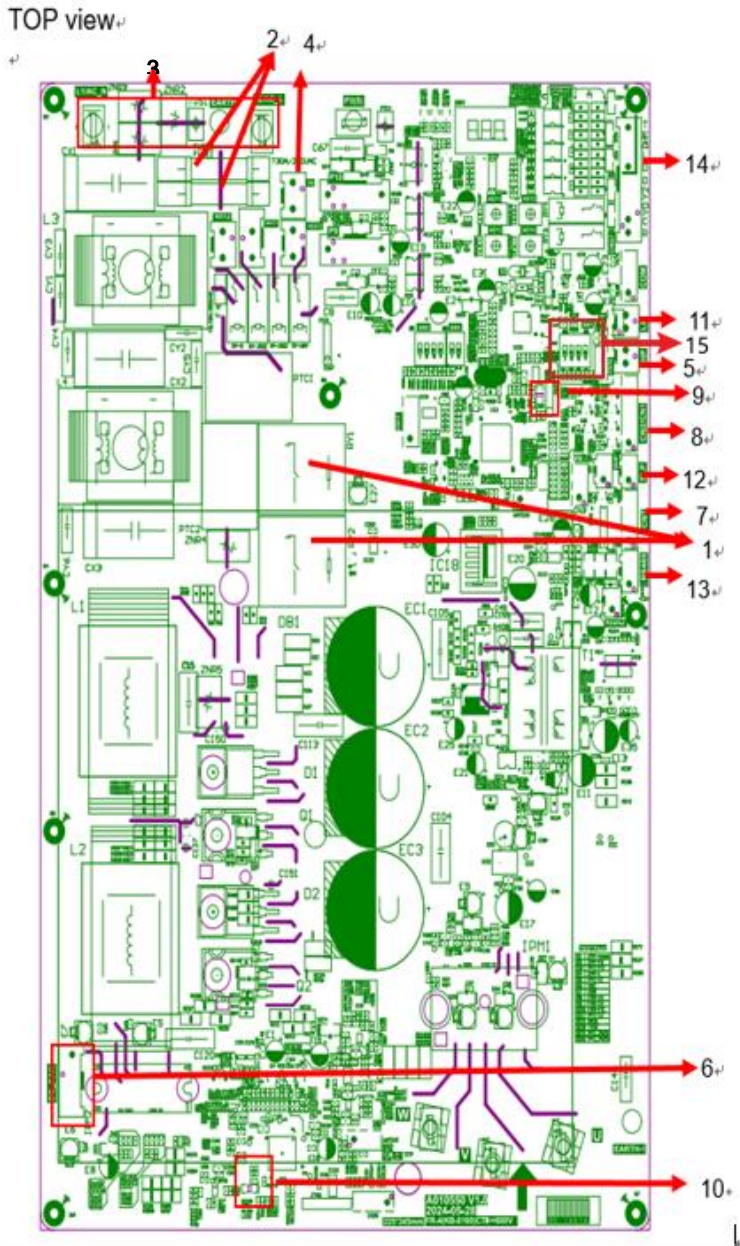

1	ODU PCB Mainly relay
2	Fuse
3	L1, L2 & P0
4	4-way valve
5	High pressure switch (HP)
6	DC fan motor connector
7	EEV
8	Temperature sensors connector
9	LED2 (Red)
10	LED1 (Red)
11	Low pressure switch (LP)
12	Pressure sensor (SHP)
13	RS485
14	AC 24V power supply
15	Dual In-line package switch 1

NOTE

LED1---- Indicates the main control IC works condition.
 When unit works normal----LED1 flashing
 When unit works abnormal -----LED1 OFF.

LED2----Indicates the compressor / DC motor driving IC status:
 When unit works normal----LED2 flashing
 When unit works abnormal -----LED2 OFF.

3.2.3 Error codes

Code	Reason	Remark
E0	IDU & ODU Communication failure	The IDU & ODU wiring connection correct?
E1	IDU Room temperature sensor failure. (Wired Controller sensor failure)	Wired Controller.
E2	IDU Tube temperature sensor failure. (IDU IPT failure)	IDU coil sensor and PCB.
E3	ODU Pipe temperature sensor failure. (OPT)	ODU pipe sensor and ODU PCB
E6	IDU PG Fan motor / DC fan motor works abnormal (IDU failure)	Fan motor, fan blade and PCB.
E7	ODU Environment temperature sensor failure	ODU environment sensor and ODU PCB.
E8	ODU Exhaust temperature sensor failure.	ODU exhaust sensor and ODU PCB.
E9	IPM / Compressor driving control abnormal.	ODU PCB, compressor, etc.
EA	ODU Current test circuit failure	ODU PCB broken?
Eb	The main PCB and display board communication abnormal	Display board and ODU PCB.
EC	The ODU PCB MCU and Fan motor / Compressor driving IC communication abnormal	ODU main PCB
EE	ODU EEPROM failure.	ODU PCB broken? Try to re-power on AC unit.
EF	ODU DC fan motor failure.	Fan motor, ODU PCB.
EU	ODU Voltage test circuit abnormal.	ODU PCB.
Ey	ODU Condenser outlet temperature sensor failure	ODU Condenser outlet sensor and ODU PCB.
P0	IPM module protection.	ODU PCB
P1	Over / under voltage protection.	ODU PCB broken? Power supply abnormal?
P2	Over current protection.	ODU PCB broken? Power supply abnormal?
P4	ODU Discharge pipe over temperature protection.	Please check the troubleshooting for detail.
P5	Sub-cooling protection on cooling mode.	Please check the troubleshooting for detail.
P6	Overheating protection on cooling mode.	Please check the troubleshooting for detail.
P7	Overheating protection on heating mode.	Please check the troubleshooting for detail.
P8	Outdoor Over temperature/Under temperature protection.	Please check the troubleshooting for detail.
P9	Compressor driving protection (Load abnormal).	Please check the troubleshooting for detail.
F0	Infrared Customer feeling test sensor failure. (IDU failure)	Querying by press remote controller

F1	Electric power test module failure. (IDU failure)	Querying by press remote controller
F2	Discharge temperature sensor failure PROTECTION.	1. The discharge temperature sensor damage 2. The discharge temperature sensor connection is loose 3. ODU main PCB damage
F3	ODU coil temperature failure PROTECTION.	1. The coil temperature sensor damage 2. The coil temperature sensor connection is loose 3. ODU main PCB damage
F4	Cooling system gas flow abnormal PROTECTION.	Please check the troubleshooting for detail.
F5	PFC PROTECTION	Please check the troubleshooting for detail.
F6	The Compressor lack of phase / Anti-phase PROTECTION.	Please check the troubleshooting for detail.
F7	IPM Module temperature PROTECTION	Please check the troubleshooting for detail.
F8	4-Way Valve reversing abnormal.	Please check the troubleshooting for detail.
F9	The module temperature test circuit failure.	ODU PCB
FA	The compressor phase-current test circuit failure.	ODU PCB
Fb	Limiting/Reducing frequency for over load protection on Cooling/Heating mode.	Querying by press remote controller
FC	Limiting/Reducing frequency for high power consumption protection.	Querying by press remote controller
Fd	The communication of refrigerant detection sensor and indoor PCB abnormal	The refrigerant sensor disengaged or faulty.
FE	Limiting/Reducing frequency for module current protection (phase current of compressor).	Querying by press remote controller
FF	Limiting/Reducing frequency for module temperature protection.	Querying by press remote controller
FH	Limiting/Reducing frequency for compressor driving protection.	Querying by press remote controller
FP	Limiting/Reducing frequency for anti-condensation protection.	Querying by press remote controller
FU	Limiting/Reducing frequency for anti-frost protection.	Querying by press remote controller
Fj	Limiting/Reducing frequency for discharge over temperature protection.	Querying by press remote controller
Fn	Limiting/Reducing frequency for ODU AC current protection.	Querying by press remote controller
Fy	Gas leakage protection	Please check the troubleshooting for detail.
H1	High pressure switch failure (HP)	1. High pressure switch damage 2. High pressure switch loose connection

		3. ODU main PCB damage
H2	Low pressure switch failure (LP)	1. Low pressure switch damage 2. Low pressure switch loose connection 3. ODU main PCB damage
H3	Pressure sensor failure (SHP)	1. pressure sensor damage 2. pressure sensor loose connection 3. ODU main PCB damage
Hd	Excessive refrigerant concentration / refrigerant leakage	1. Is there R32 gas leakage? 2. Are there polluting gases around the environment? 3. Refrigerant test sensor fault? 4. Indoor PCB defective?
C5	Communication fault of the Wired Controller and indoor unit main PCB.	1. Check the connection of the wired controller and PCB; 2. Indoor PCB defective ? 3. The wired controller failed ?
dA	The indoor supply air temperature sensor failure	Check the sensor and PCB

Note: Remote controller FAILURE CODE Querying function

As shown in the failure codes, some of the codes (Fb~bj) need to press remote control for inspection. While unit on operation, press the ECO button 8 times with 8 seconds, the buzzer BIBI 2 times, you can inspect the special failure code as Fb~Fn, bj etc.

3.2.4 Trouble shooting

3.2.4.1 E0 ---IDU & ODU communication failure

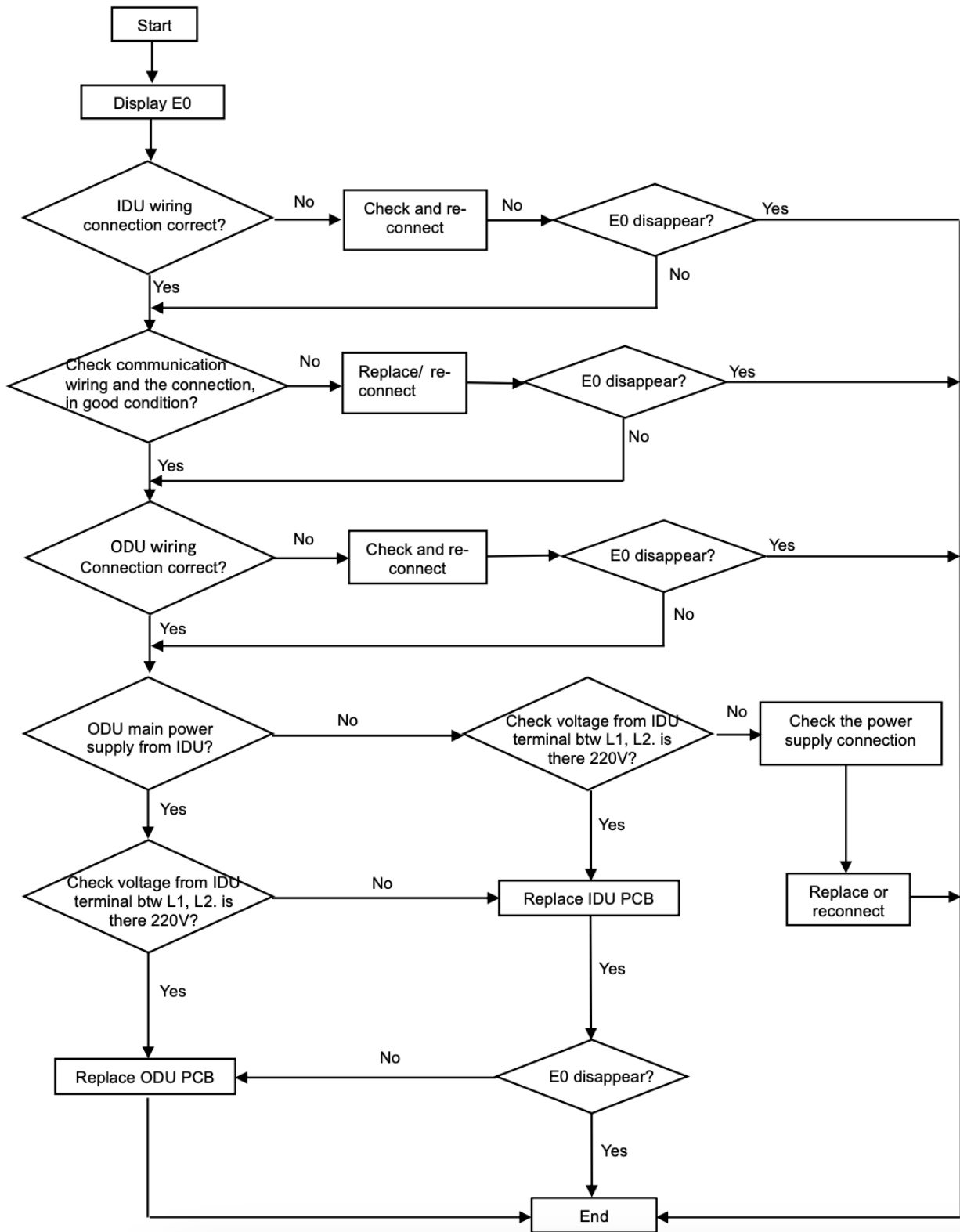

3.2.4.2 E3, E7, E8 or Ey---ODU Coil temperature sensor, Ambient temperature sensor or Discharge temperature sensor, Condenser outlet temperature failure.

When any of sensor resistance open or short circuit, the unit will display failure code as E3, E7, E8 or Ey, IDU and ODU turns off. When the sensor resistance recovery, unit revert to be standby, customer can switch on the unit directly.

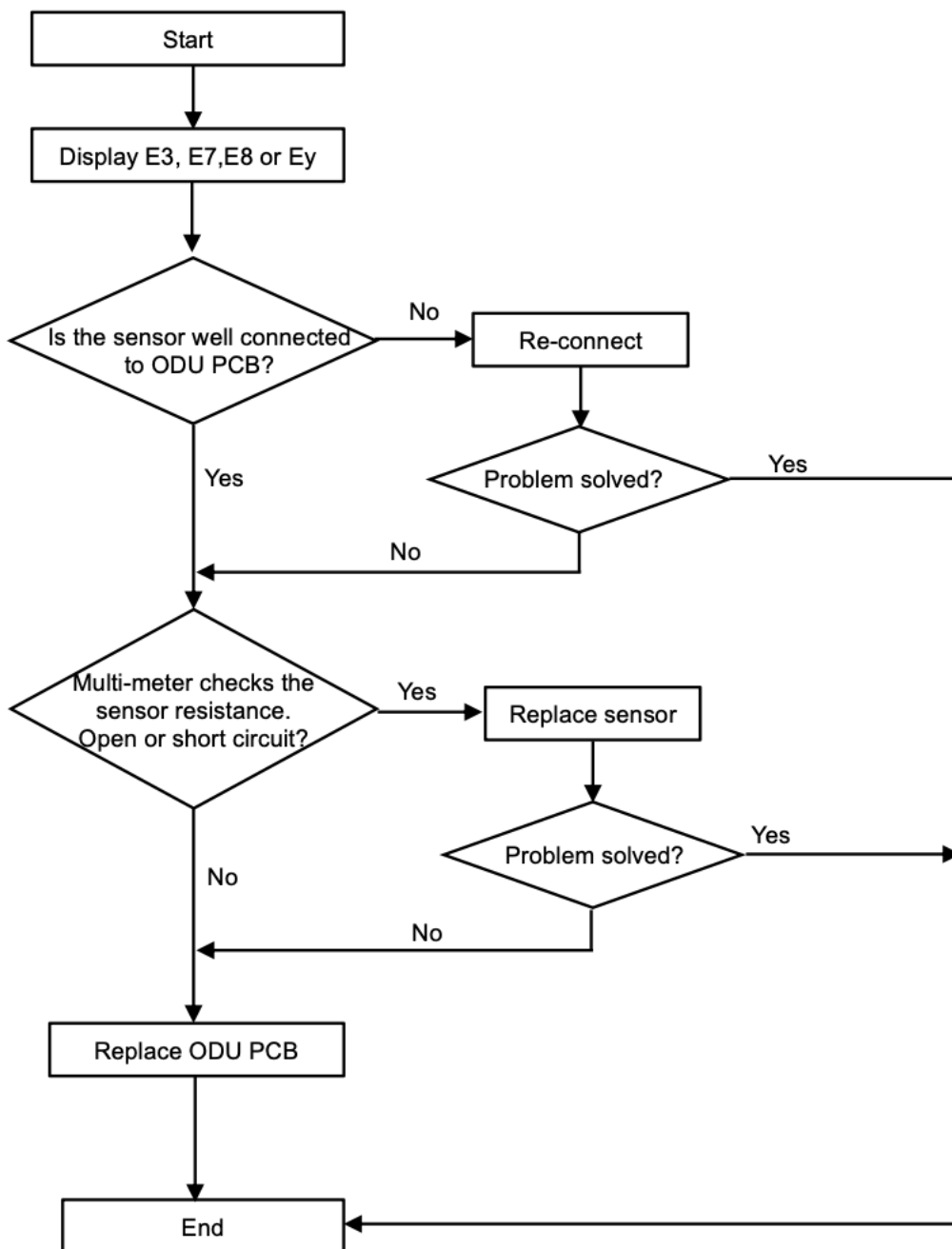

3.2.4.3 E9---ODU IPM /Compressor driving fault

If unit have 6 times stopping works for IPM protection continuously, it will display E9 error, and unit can't be recovered to operation, except press ON/OFF button.

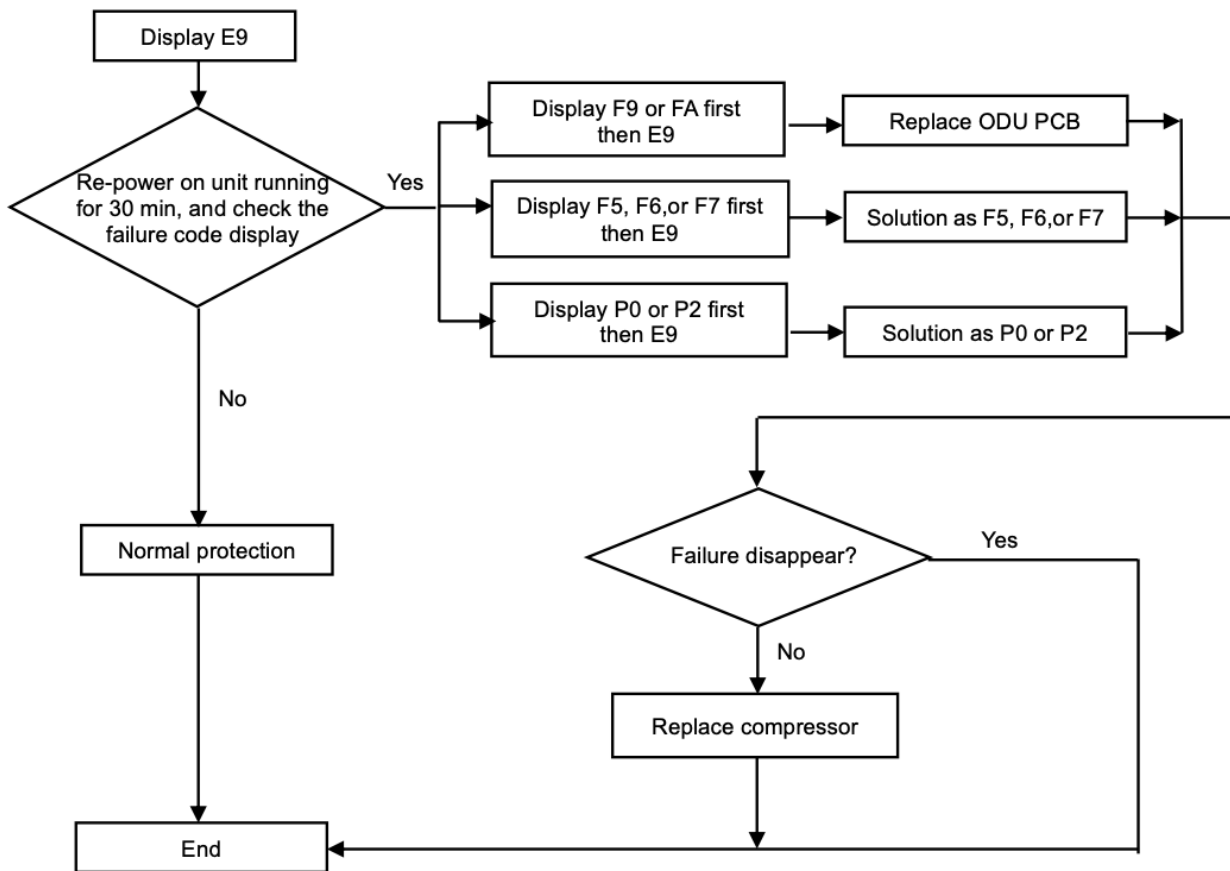

3.2.4.4 EA—ODU current sampling failure

Cause: Outdoor current sampling circuit failure or driver parameter mismatch

Solution: Replace the ODU PCB.

3.2.4.5 Eb—ODU communication abnormal of main board and display board

- Cause:**
1. The communication wire damaged.
 2. Outdoor main board damaged
 3. Display board damaged.

- Solution:**
1. Replace the communication wire.
 2. Replace the outdoor main board.
 3. Replace the display board.

3.2.4.6 EC—Communication Error btw ODU PCB MCU and Fan motor / Compressor driving IC

Cause: The ODU mainboard damaged

Solution: Replace the ODU PCB.

3.2.4.7 EE—ODU EEPROM failure.

Cause: The ODU mainboard damaged.

Solution: Replace the ODU PCB.

3.2.4.8 EF---ODU DC fan motor failure

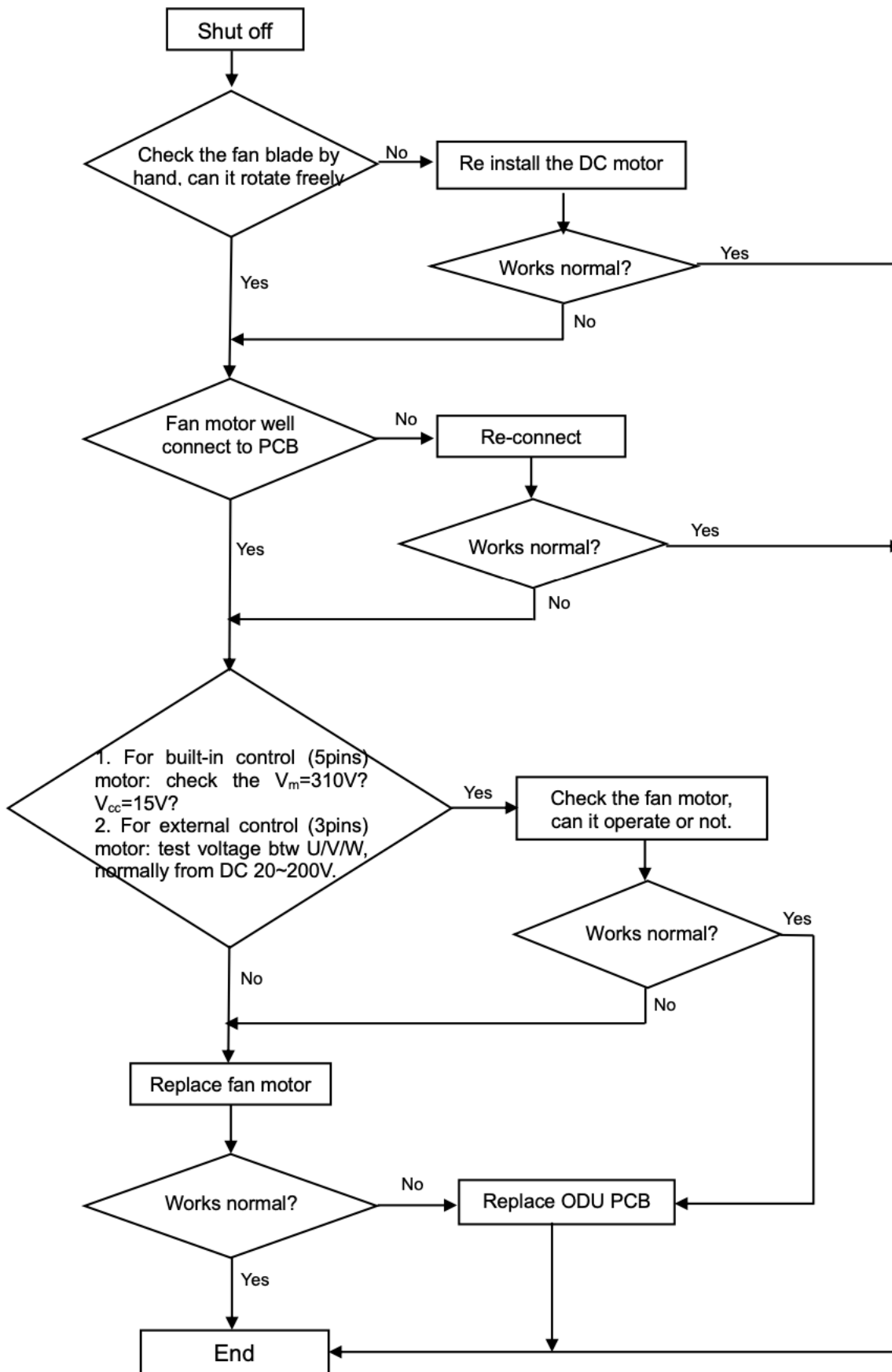

3.2.4.9 EU---ODU voltage test sensor failure

After power relay works, while tested voltage effective value less than 50V for 3s continuously, unit will display EU.

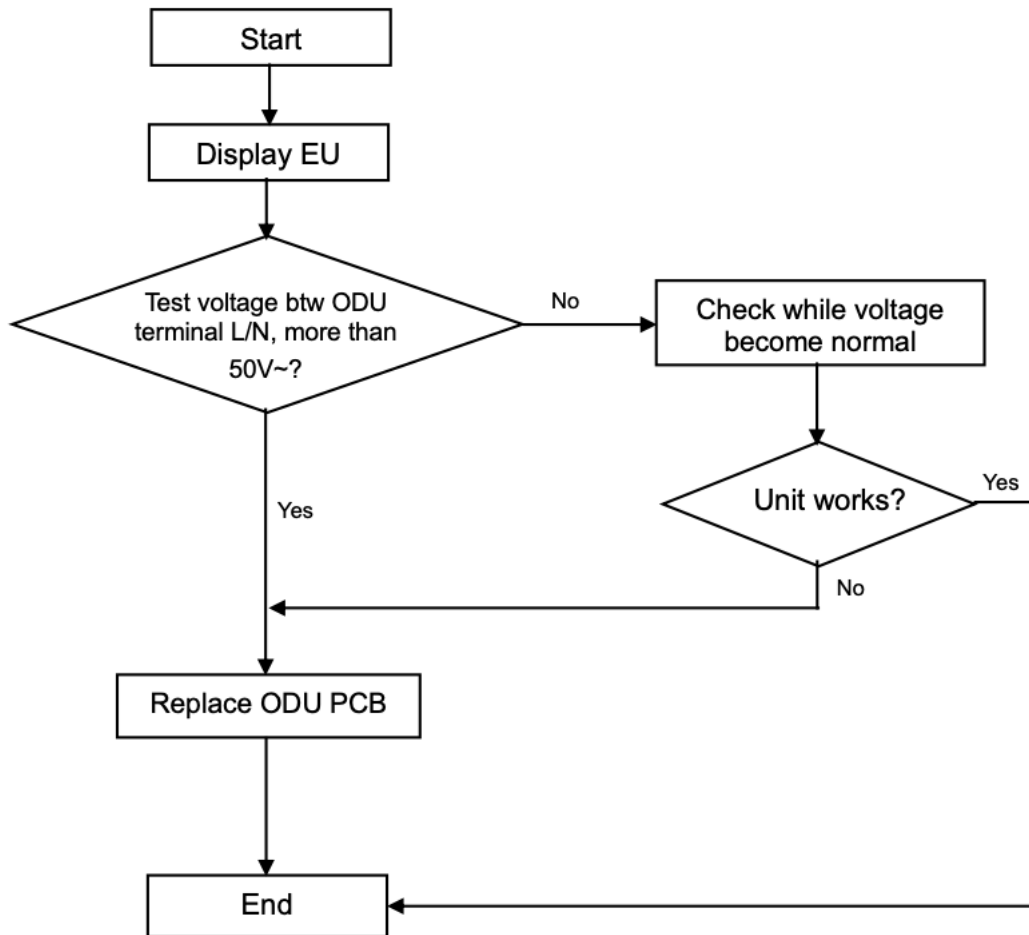

3.2.4.10 P0---IPM protection

When overheat or overcurrent for IPM, AC unit will display P0 protection.

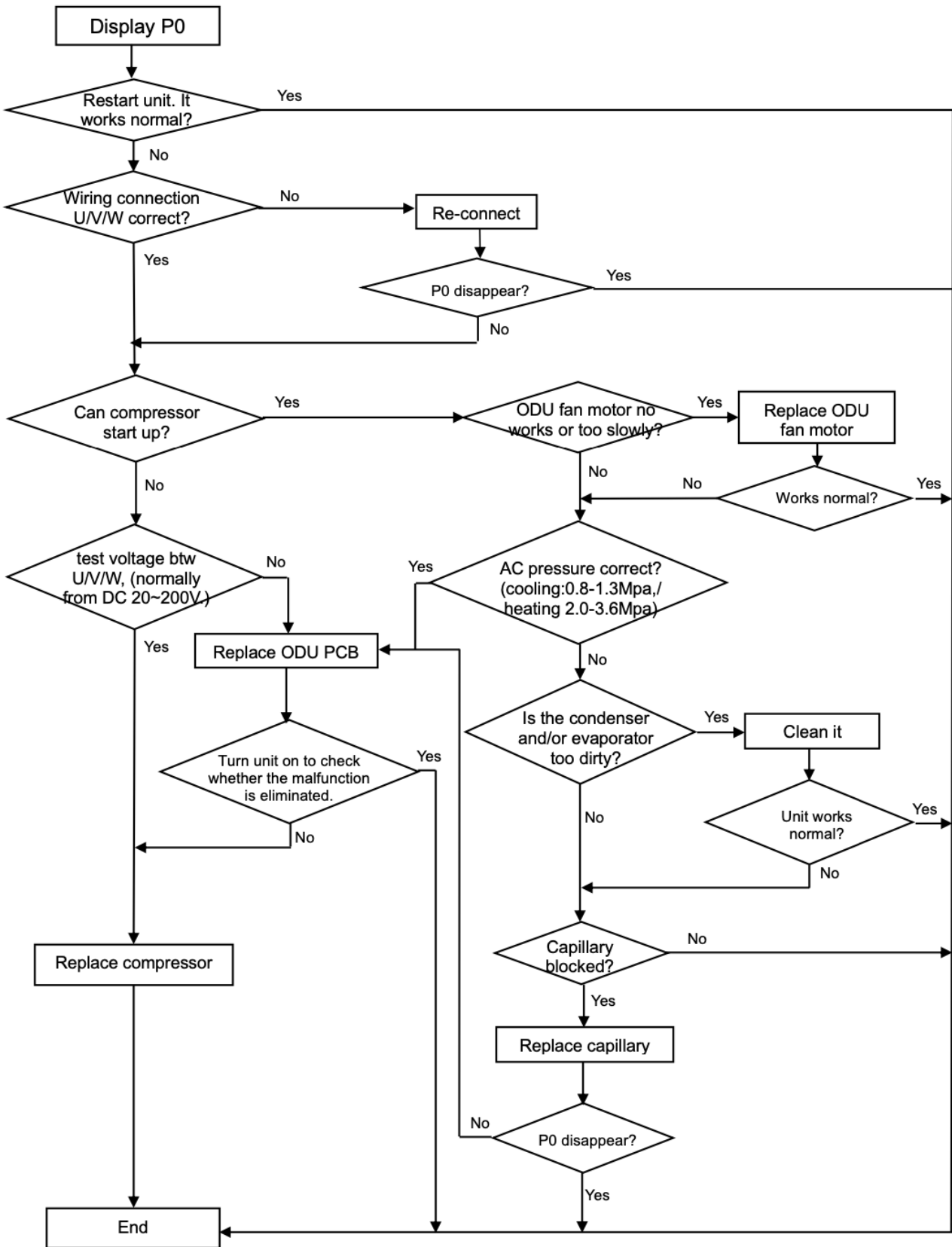

3.2.4.11 P1--- Over / under voltage protection

1. Test voltage between L1 & L2, When the power supply $V > AC260V$ or $V < AC150V$, AC will display P1 protection, unit will recover back to previous status while $V > AC155V$.
2. Test voltage on the big size electrolytic capacitor of ODU PCB, When DC busbar voltage $V > DC420V$ or $V < DC150V$, IDU display P1 protection. unit will recover back to previous status while $DC190V < V < DC410V$

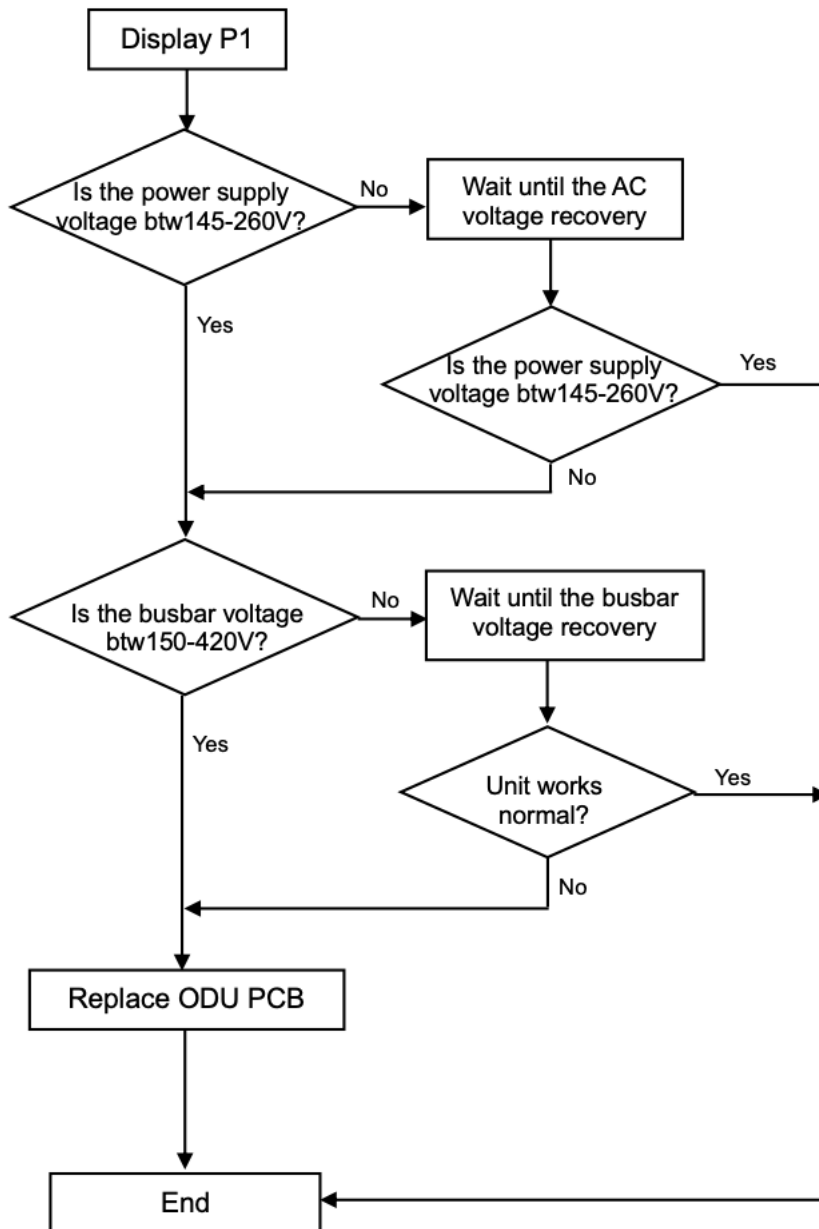

3.2.4.12 P2---Over Current protection

When the AC unit running current more than I_{max} , it will stop and display P2 protection.

Note: for different AC model, I_{max} has a difference valve , I_{max} .=Maximum current.

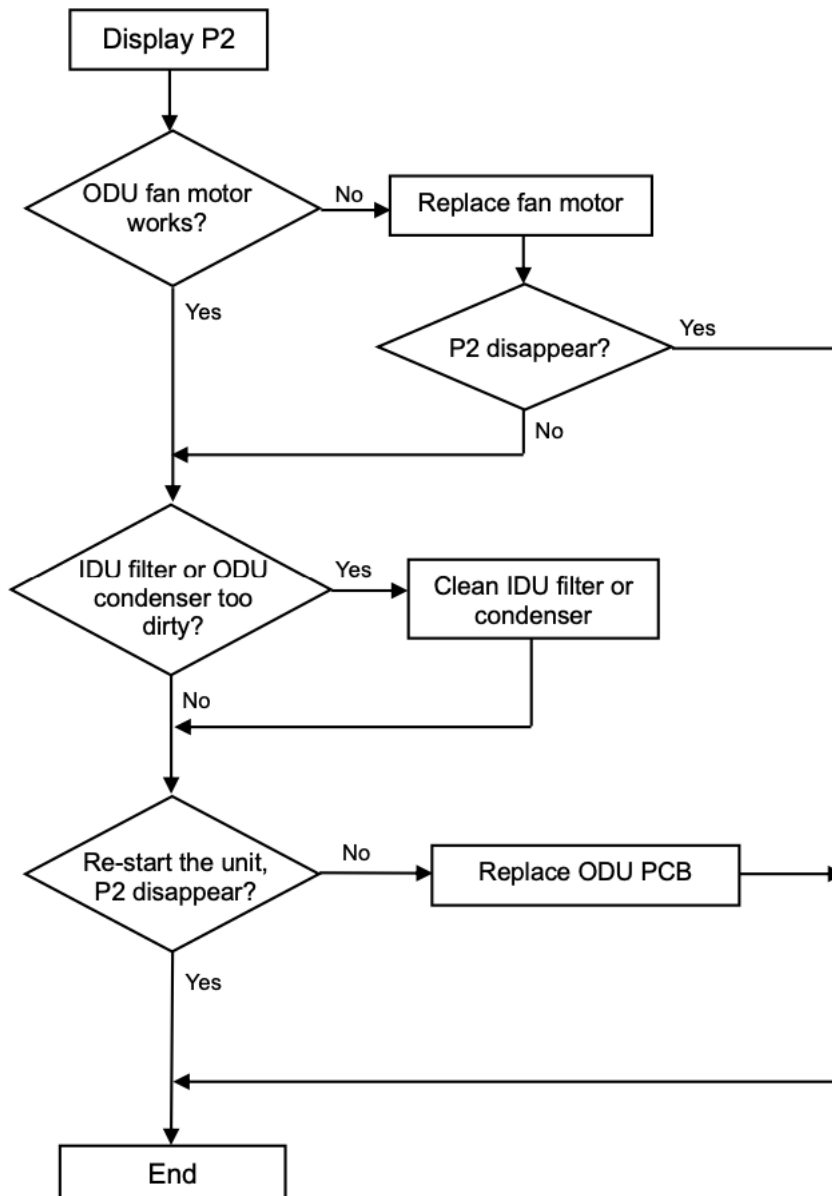

3.2.4.13 P4 ---ODU Discharge temperature overheating protection

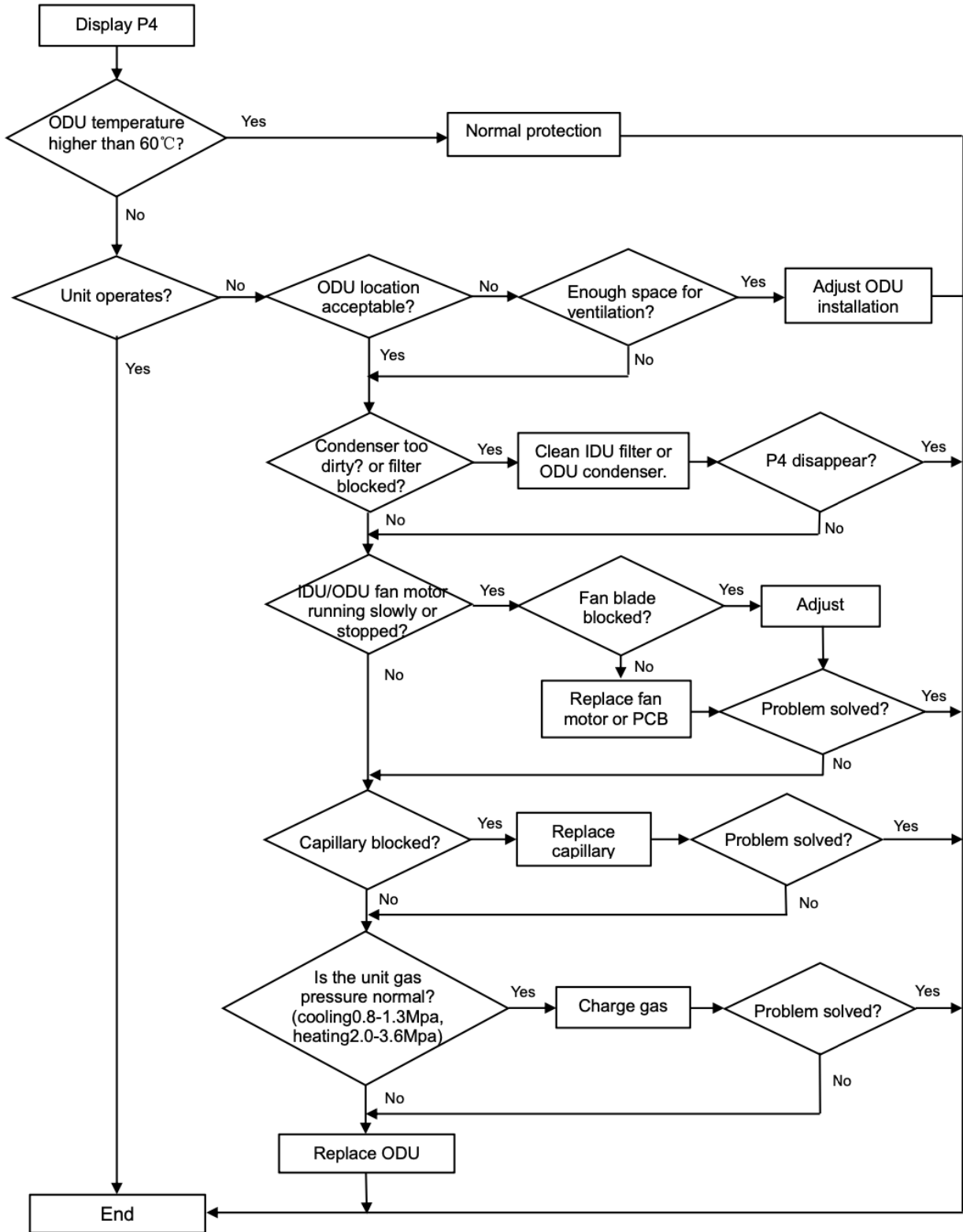

3.2.4.14 P5---Anti-freezing protection on Cooling/Dry mode

On Cooling or Dry mode, when IDU evaporator coil temperature IPT < 34°F continuously for 3 min after compressor start up for 6 min, CPU will switch off outdoor unit and show P5 failure code.

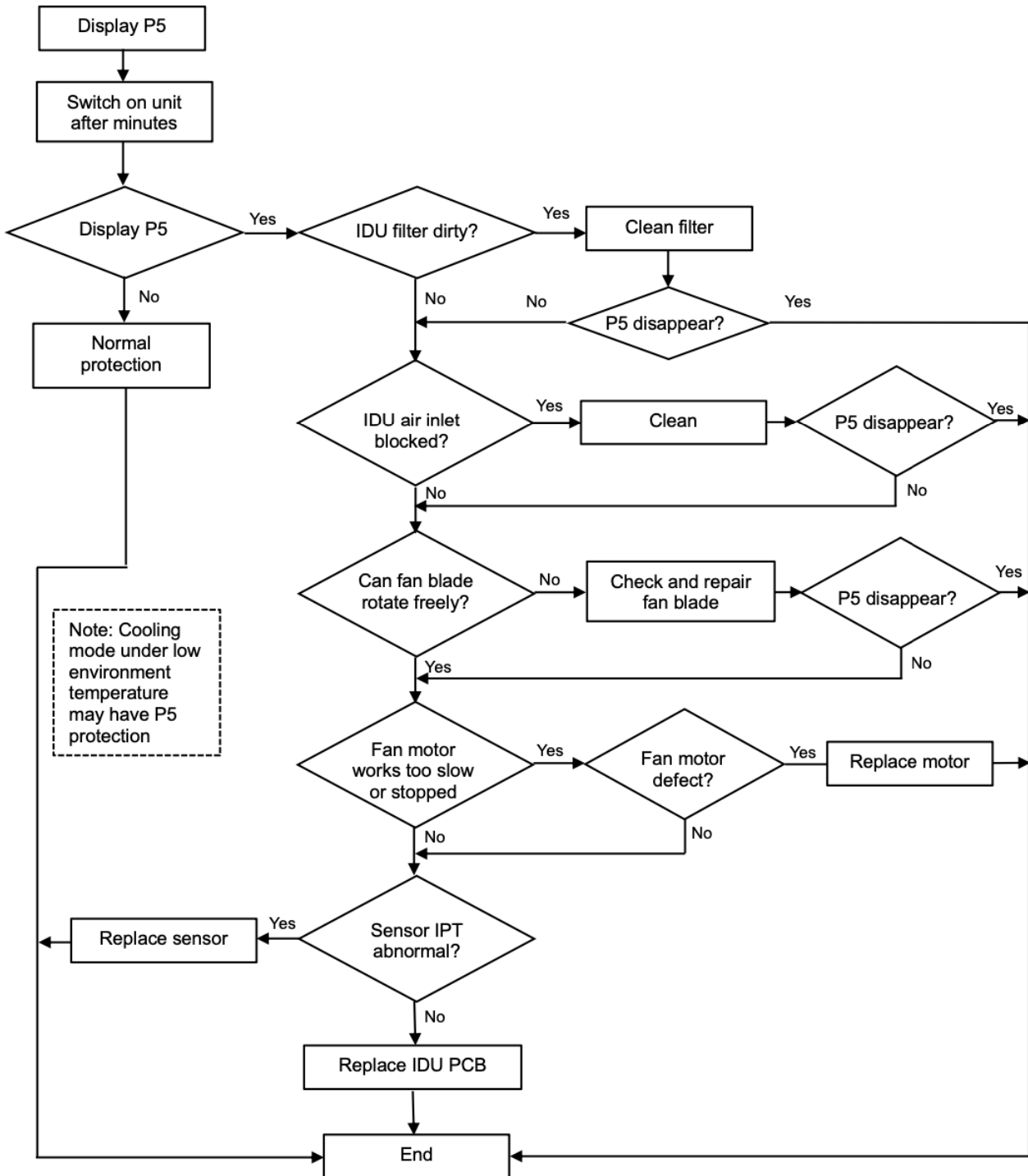

3.2.4.15 P6---Overheating protection on Cooling mode

On Cooling or Dry mode, when ODU condenser coil temperature $OPT \geq 144^{\circ}F$, MCU will switch off outdoor unit and show P6 failure code.

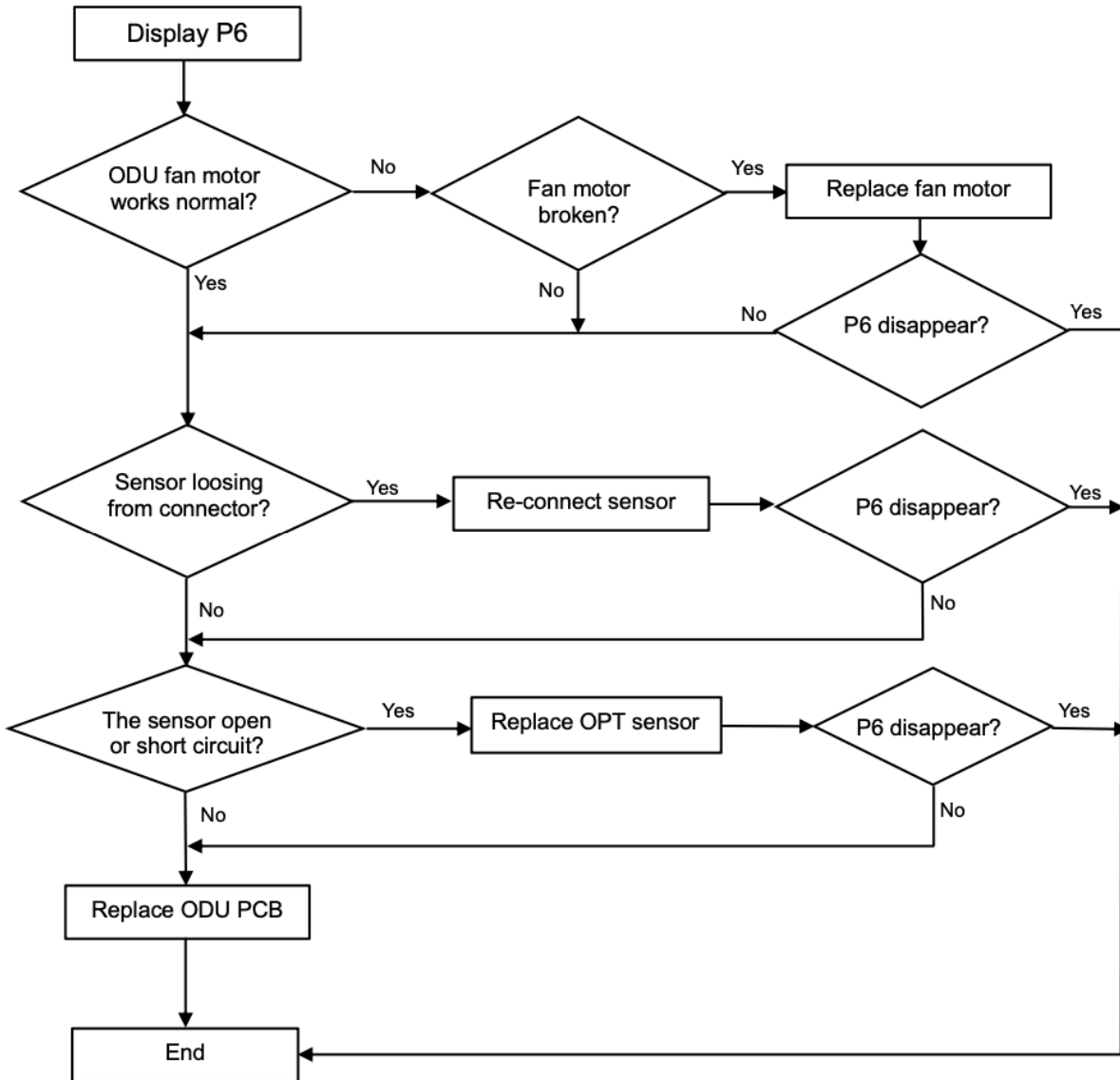

3.2.4.16 P7---Overheating protection on Heating mode

On heating mode, when IDU evaporator coil temperature $IPT \geq 144^{\circ}F$, IDU PCB will switch off outdoor unit and show P7 failure code.

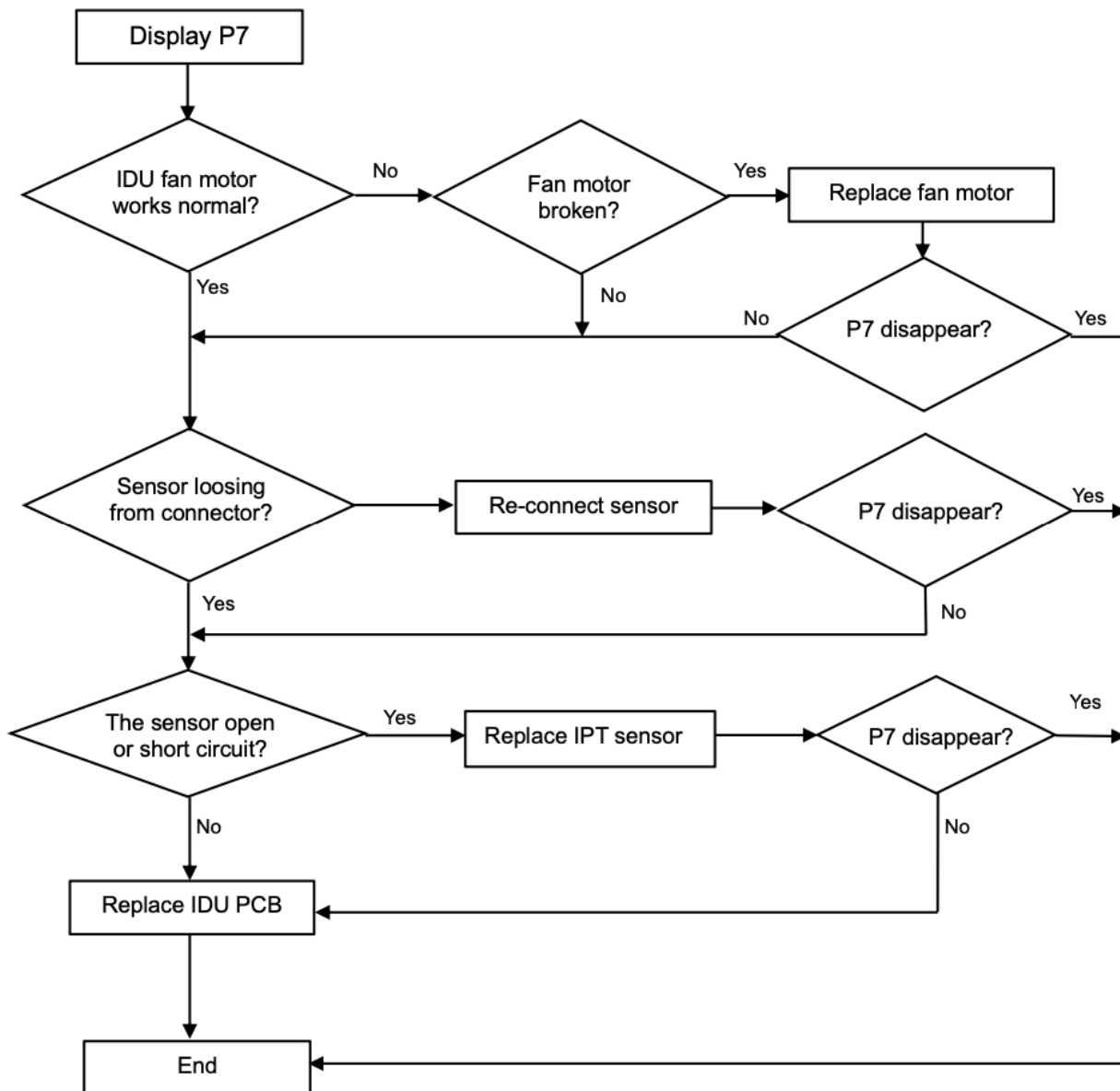

3.2.4.17 P8---Outdoor Overtemperature/Under-temperature protection

When environment temperature as below condition, the compressor will stop working, after 200s delay, the IDU will show P8 failure code.

(1). **On Cooling or Dry mode:** ODU ambient temperature: $OAT < -4^{\circ}F$ or $OAT > 145^{\circ}F$;

(2). **On Heating mode:**

a. $OAT \geq 104^{\circ}F$ or

b. $86^{\circ}F < OAT \leq 104^{\circ}F$ and $RT > 95^{\circ}F$

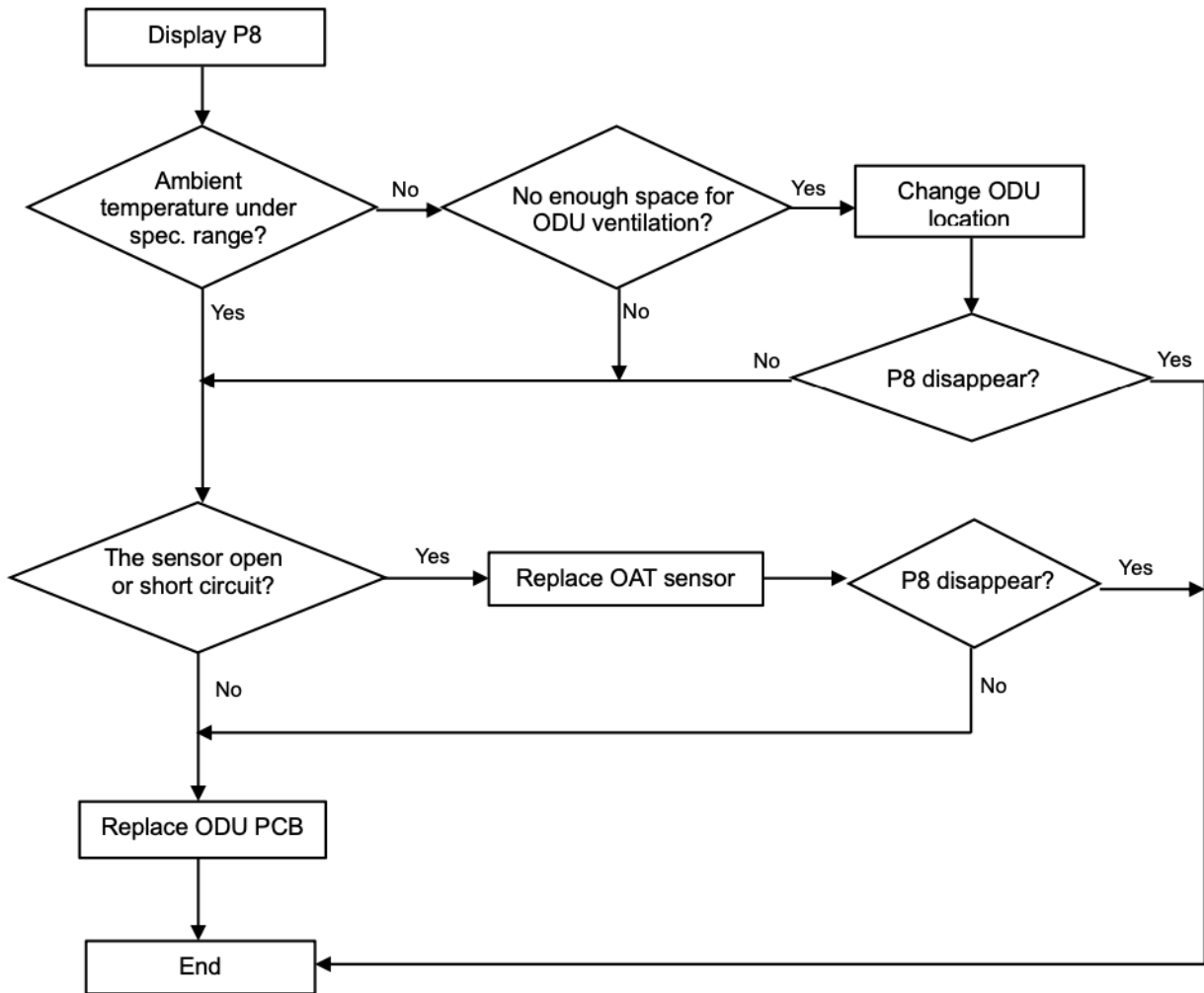

3.2.4.18 P9---The compressor driving protection (the compressor load abnormal)

When compressor start up or in the process of operation, if:

- (1). MCU can't test the feedback signal from compressor, or
- (2). Tested an abnormal signal from compressor, or
- (3). The compressor startup abnormal.

The outdoor unit will shut off, and show P9 protection.

(The unit will re-startup 6 times continuously, if it still can't work normal, then show P9 code)

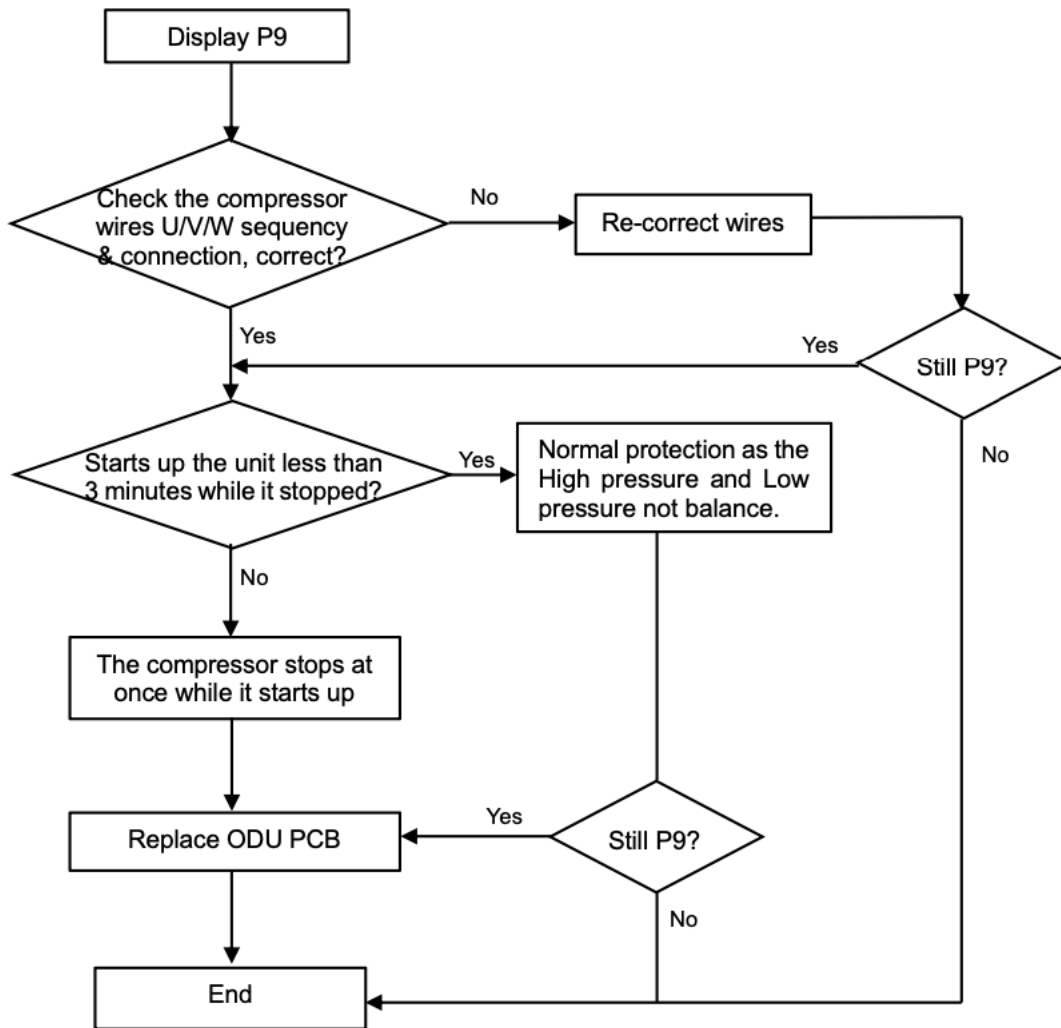

3.2.4.19 F4---Cooling system Gas flow abnormal protection

When compressor startup, unit will check the variation of IDU coil temperature. If there is mistake installer forgetting to open the 2-way or 3-way valve on ODU, the gas can't flow in the cooling system, it will show F4 protection.

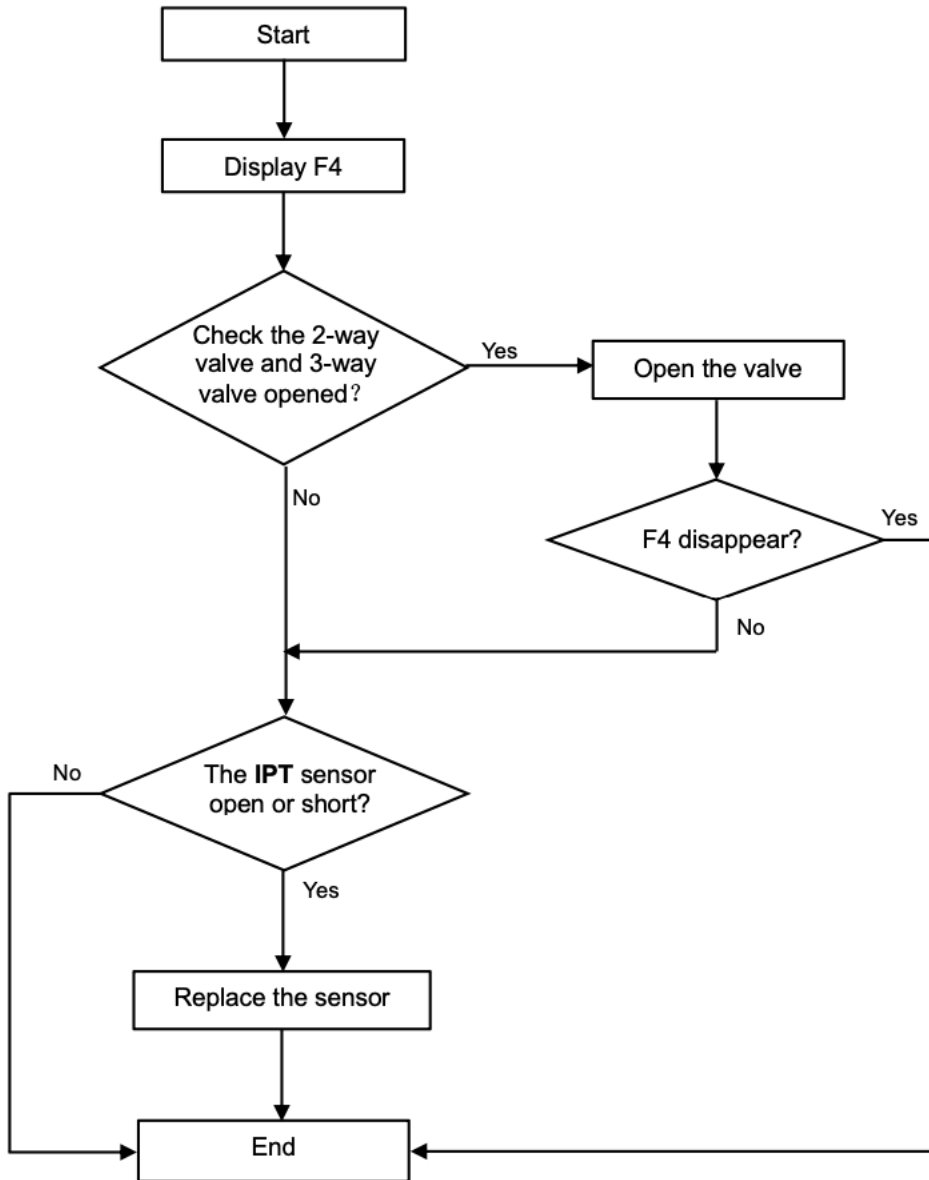

3.2.4.20 F5---PFC Protection

PFC Overcurrent protection

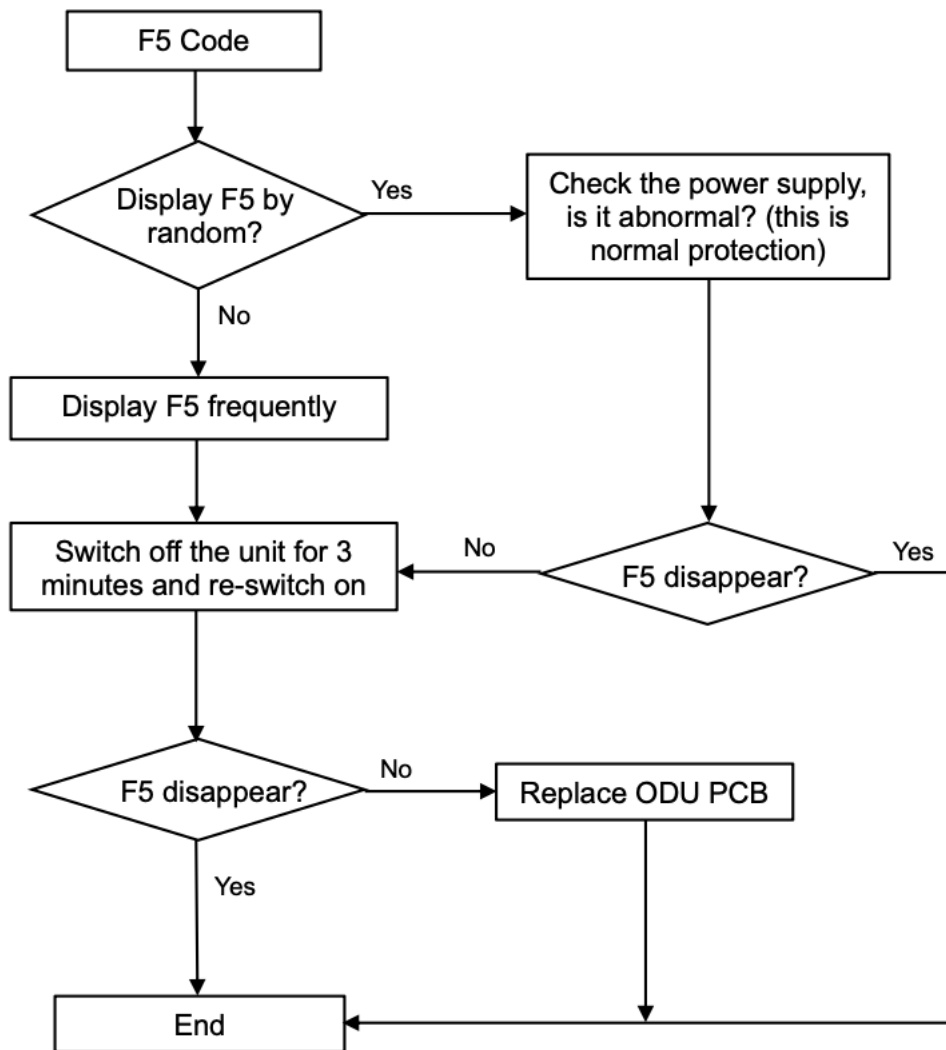

3.2.4.21 F6---The Compressor Lack of phase / Anti-phase protection.

If ODU PCB can't test one, two or even three phases of compressor current, it will show F6 protection.

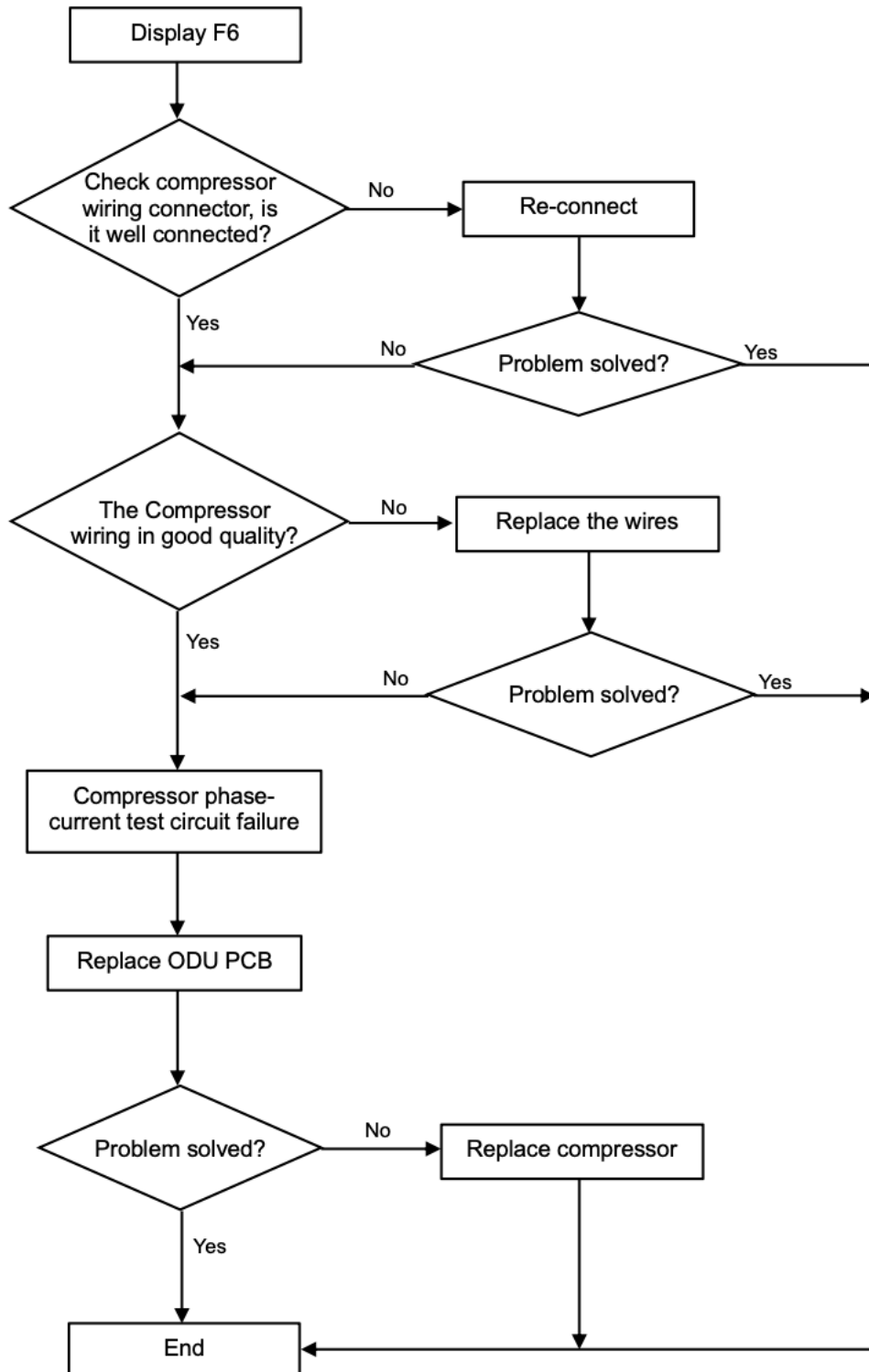

3.2.4.22 F7---Module temperature protection.

IPM overtemperature protection, when IPM temperature more than 203°F, it will show F7.

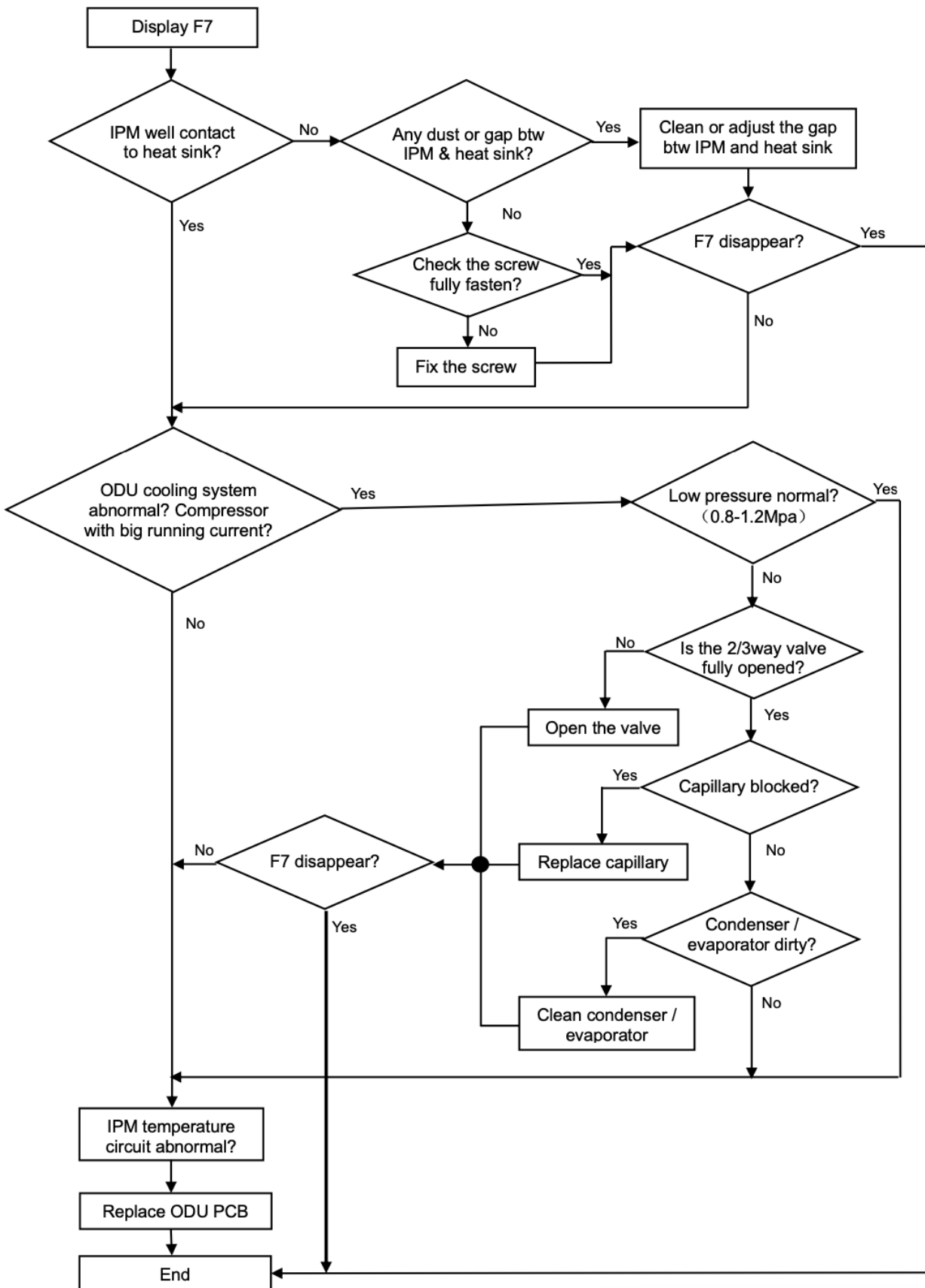

3.2.4.23 F8---4-Way Value Reversing abnormal

On heating mode, if IDU Coil temperature tested lower than Room temperature 9°F or even more after compressor works for 8min, unit will show F8 code.

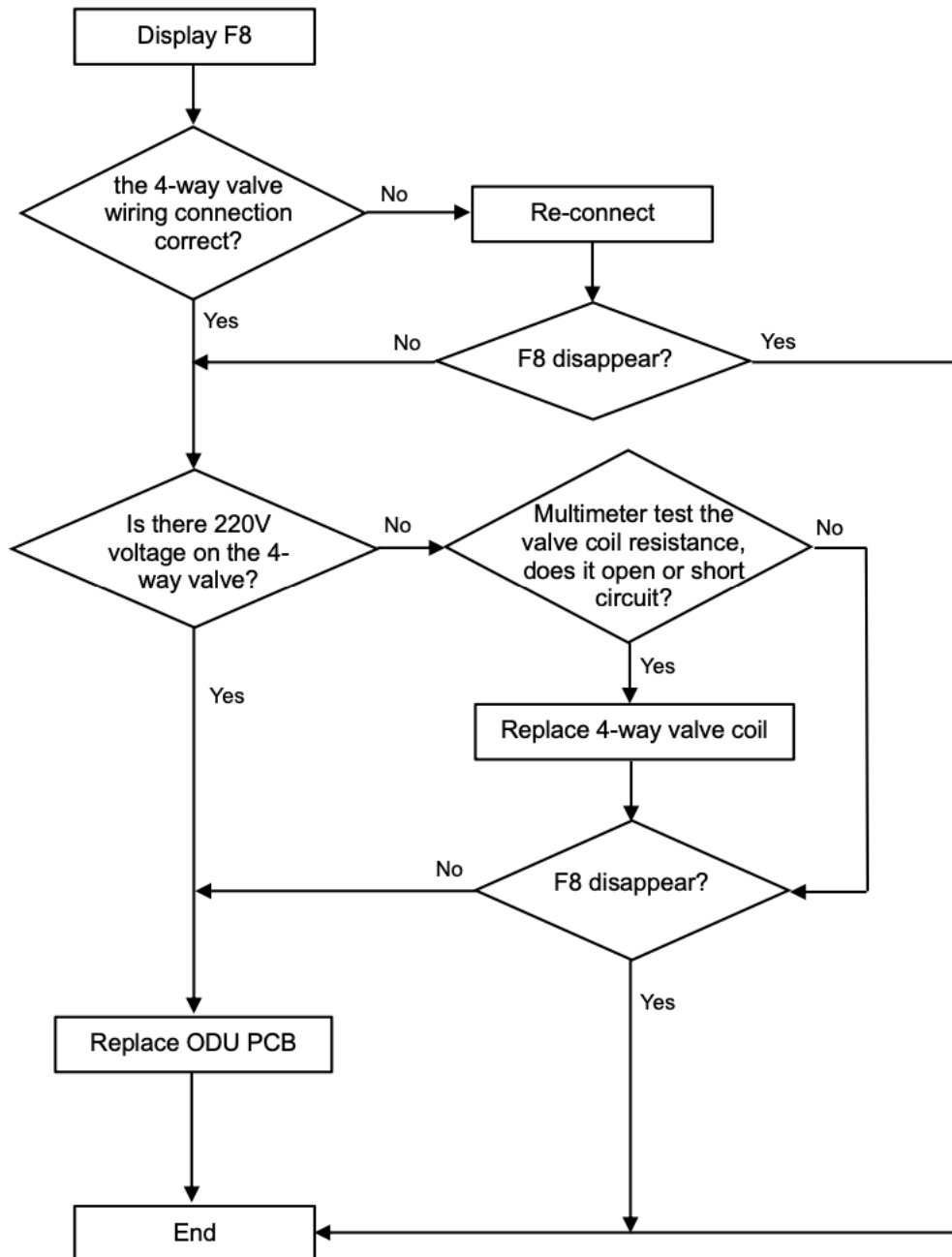

3.2.4.24 F9—The module temperature test circuit failure

Reason: The IPM module temperature test circuit failure.

Solution: Replace the ODU PCB.

3.2.4.25 FA—The compressor Phase-current test circuit failure

Reason: The IPM module temperature test circuit failure.

Solution: Replace the ODU PCB.

3.2.4.26 Fy--- Gas leakage protection

After compressor works in high frequency for 9 min, if the temperature on IDU evaporator & ODU condenser has only a little variation comparing previous, but, the compressor discharge temperature on high level, then the unit will show Fy failure code.

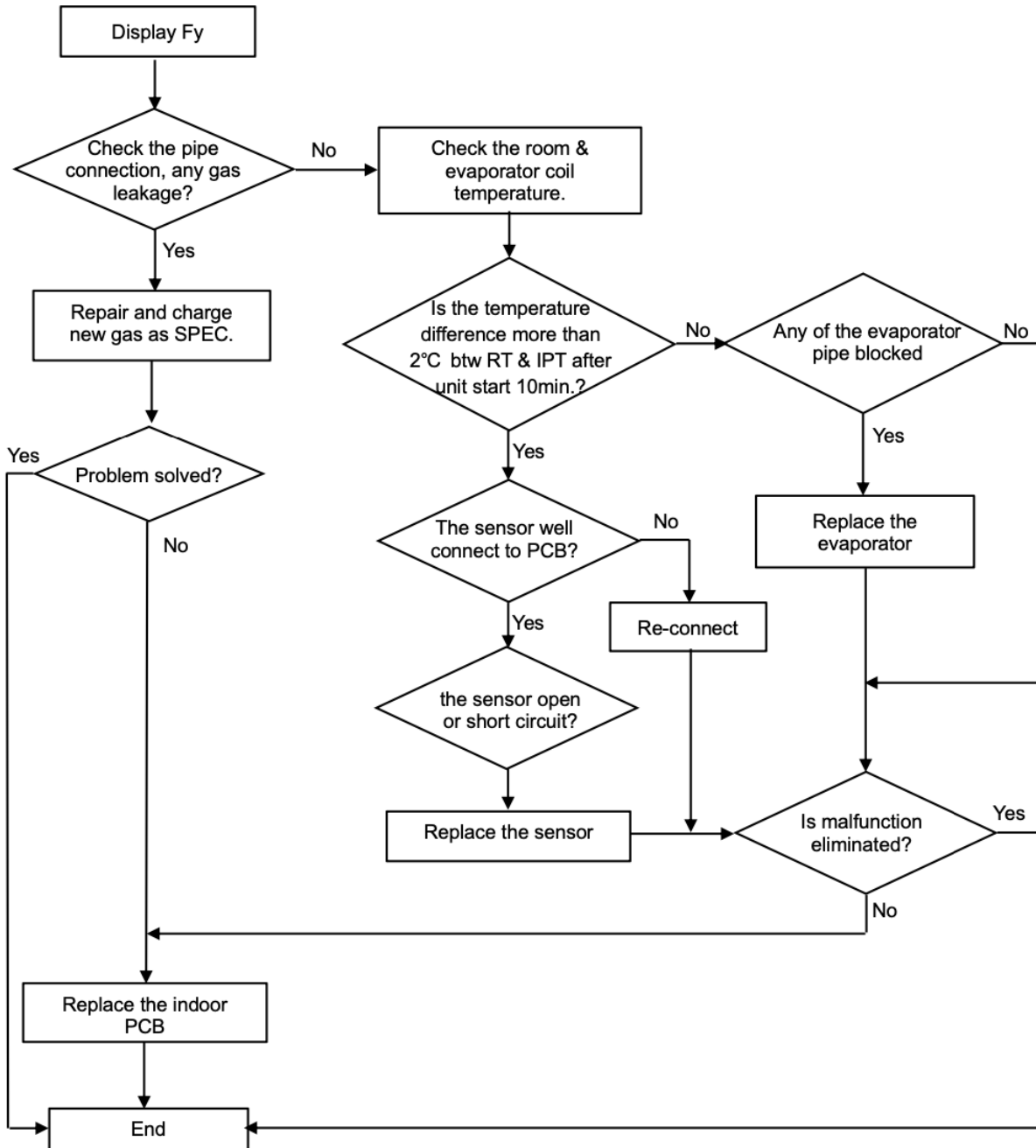

3.2.4.27 H1,H2,H3 & H4 — High pressure/Low pressure switch, Pressure sensor test abnormal.

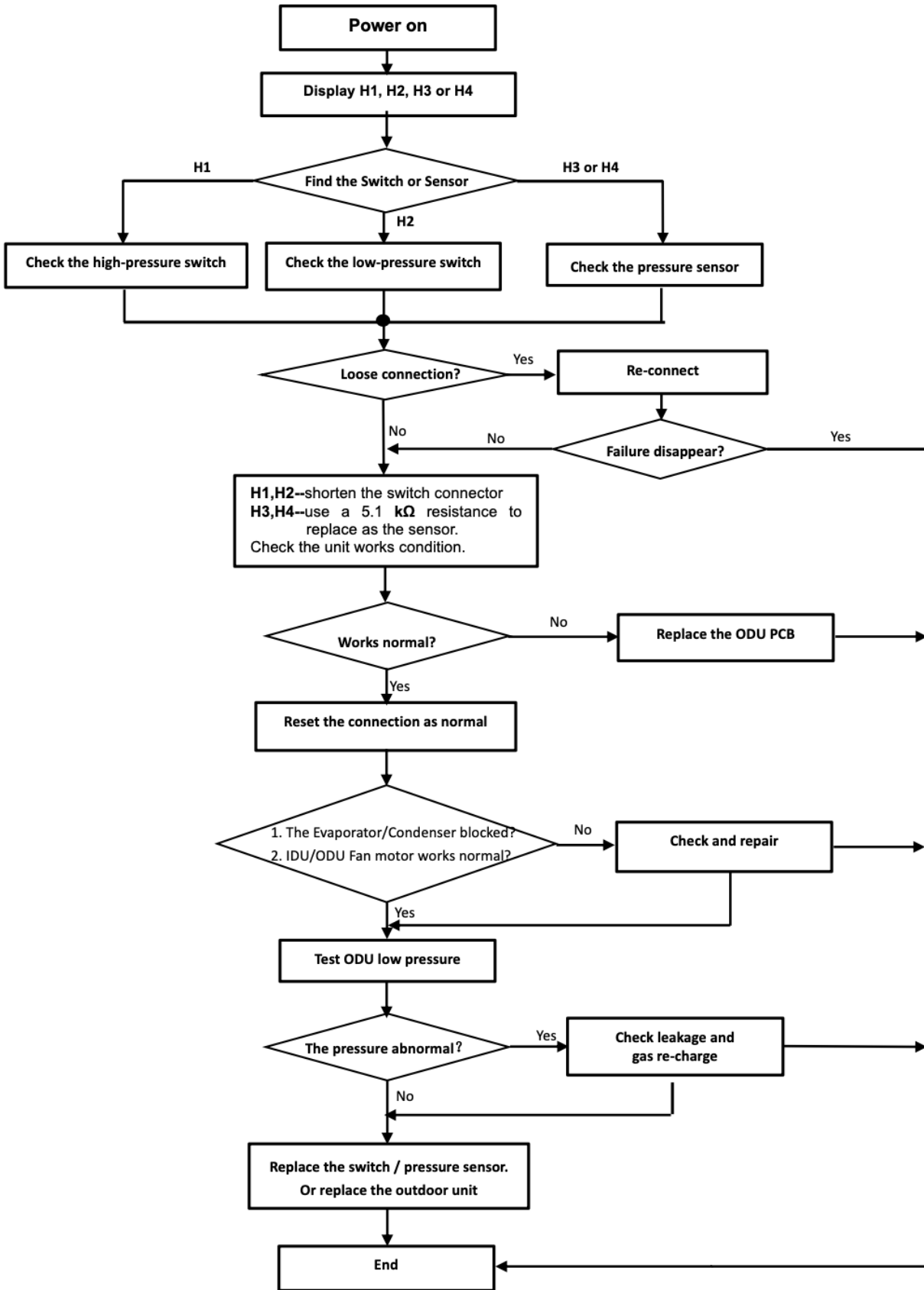

3.2.4.28 Fd — The communication of refrigerant detection sensor and indoor PCB abnormal

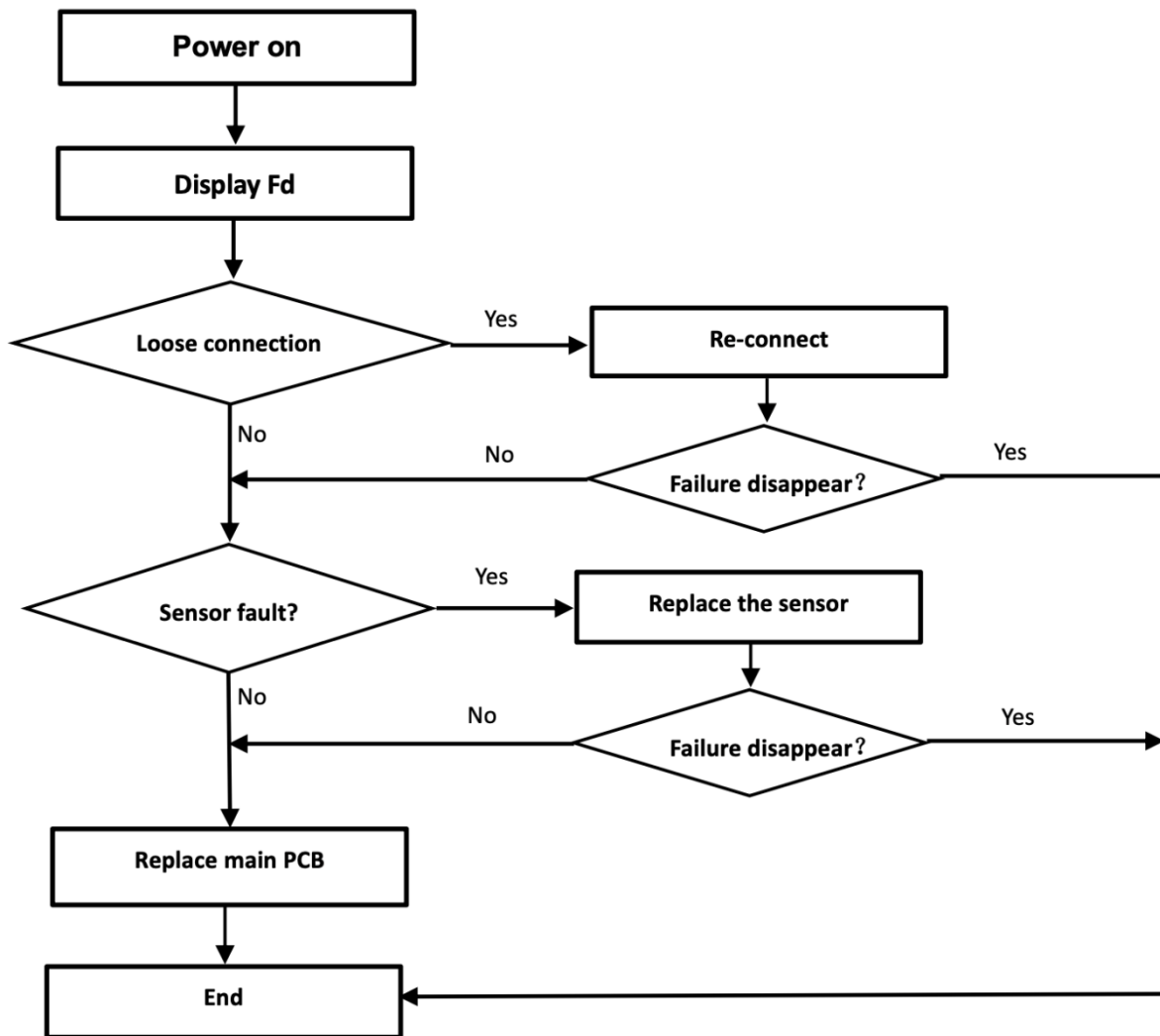

3.2.5 Failures Not Caused by Errors

The following symptoms are not a malfunction and no need repairing.

Problem	Possible Cause
Abnormal noises of outdoor unit	The unit will make different sounds based on its current operating mode.
Both the indoor and outdoor units make noises	The air conditioner may hum during operation. This is a normal phenomenon, which is caused by refrigerant gas flowing through the indoor and outdoor units.
	When the air conditioner is turned on, and just stopped or defrosted, a hiss may be heard. This noise is normal and is caused by refrigerant gas stopping or turning.
Unit does not turn on when pressing ON/ OFF button	The unit has a 3-minute protection feature that prevents the unit from overloading. The unit cannot be restarted within three minutes of being turned off.
	Cooling and Heating Models: If the Operation light and PRE-DEF (Pre-heating/ Defrost) indicators are lit up, the outdoor temperature is too cold and the unit's anti-cold wind is activated in order to defrost the unit.
The unit changes from COOL mode to FAN mode	The unit changes its setting to prevent frost from forming on the unit. Once the temperature increases, the unit will start operating again.
	The set temperature has been reached, at which point the unit turns off the compressor. The unit will resume operating when the temperature fluctuates again.
Both the indoor and outdoor units emit white mist	When the unit restarts in HEAT mode after defrosting, white mist may be emitted due to moisture generated from the defrosting process.
Dust is emitted from either the indoor or outdoor unit	The unit may accumulate dust during extended periods of nonuse, which will be emitted when the unit is turned on. This can be mitigated by covering the unit during long periods of inactivity.
The unit emits a bad odor	The unit may absorb odors from the environment (such as furniture, cooking, cigarettes, etc.) which will be emitted during operations.
	The unit filters have become moldy and should be cleaned.
The fan of the outdoor unit does not operate	During operation, the fan speed is controlled to optimize product operation.

3.3 Maintenance

3.3.1 System diagram

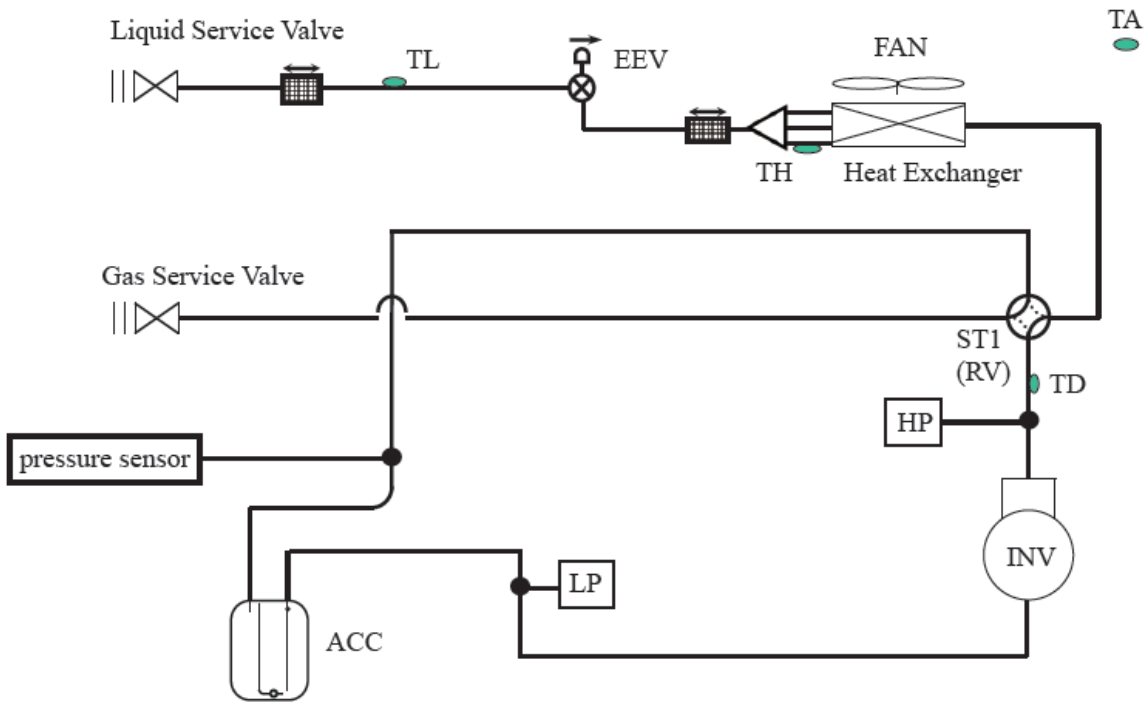

Name	Symbol	Function
Inverter compressor	INV	Adjusts refrigerant flow rate by changing the speed (RPS) based on objective pressure.
DC motor	FAN	Outputs heat exchanger capacity by adjusting the motor rotation speed based on operating pressure.
Electronic expansion valve	EEV	Fully open in cooling mode and defrost operation. Control compressor discharge superheat in heating mode.
Reversing valve	ST1 (RV)	Switches the operation mode between heating and cooling (including defrost control).
Temperature sensor	TH	Uses to control defrost during heating operation.
	TA	Uses to detect outdoor air temperature and control fan speed.
	TL	Uses to detect liquid line temperature and calculate sub-cooling (SC).
	TD	Uses to detect compressor discharge temperature and calculate discharge: superheat (DSH).
	TF	Uses to detect heatsink temperature of inverter module.
High pressure switch	HP	Uses to detect high pressure.
Low pressure switch	LP	Uses to detect low pressure.
Accumulator	ACC	To prevent the compressor from ingesting liquid refrigerant

3.3.2 Connection pipe vacuum pumping

1. Use vacuum Pump

- 1) Air and humidity left inside the refrigerant circuit can cause compressor malfunction. After having connected the indoor and outdoor units, bleed the air and humidity from the refrigerant circuit by using a vacuum pump.
- 2) Open the piezometer and operation for 30-40minutes to check if the pressure of piezometer remains in **-0.1Mpa**.
- 3) Close the vacuum pump and maintain this status for 5-8min to check if the pressure of piezometer remains in **-0.1Mpa**. If the pressure decrease, there may be leakage.
- 4) Remove the piezometer, open the valve core of liquid valve and gas valve completely.
- 5) Tighten the screw caps of valve and refrigerant charging vent.

2. Leakage Detection

- 1). With leakage detection.
Check if there is leakage with leakage detection.
- 2). With soap water. If leakage detection is not available, please use soap water for leakage detection. Apply soap water at the suspected position and keep the soap water for more than 3min. If there are air bubbles coming out of this position, there a leakage.

3.3.3 Refrigerant charging

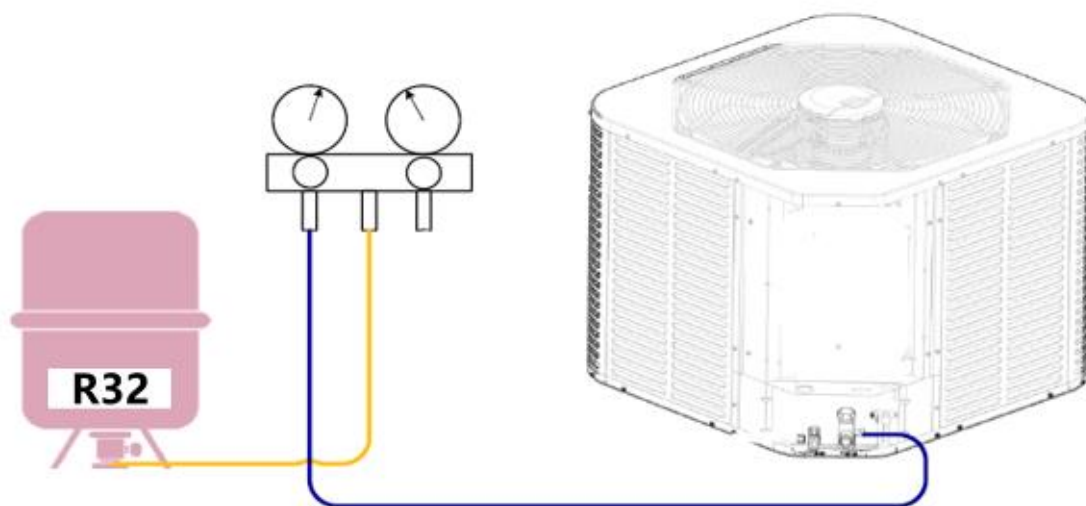

The refrigerant filling volume of the outdoor unit is a standard connecting pipe length of 25ft.

If a long connecting pipe is required, refrigerant should be filled additionally. 0.0335lbs/ft is added to the unit for cooling by inverting the refrigerant tank and adding refrigerant at the low-pressure shut-off valve.

Pipe Length and Additional Refrigerant

Pipe Length and Additional Refrigerant

Model	24K	36K	48K	60K
Length of pipe with standard charge (ft)	25	25	25	25
Refrigerant capacity of standard charge (lbs)	3.97	5.51	7.72	7.72
The longest pipe length (ft)	98	98	164	164
Additional refrigerant charge (lbs/ft)	0.0167	0.0167	0.0167	0.0167
Max. diff. in level between indoor and outdoor unit (ft)	49	49	82	82

For example, for a 36K model, when the pipe is 100ft, the additional refrigerant charging is $(100-25) \times 0.0167 = 1.25$ lbs, and the refrigerant capacity of the whole model is $5.51 + 1.25 = 6.77$ lbs.

3.3.4 Maintenance of major components

Indoor unit: control board, centrifugal motor, thermistor, refrigerant leakage sensor, etc.

Outdoor unit: electronic control, axial fan, etc.

Disassembly and assembly can be conducted as instructed below.

3.3.5 Removal of major components

Disassemble of Indoor unit

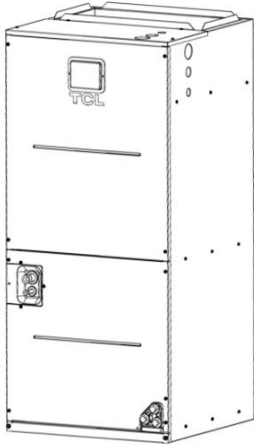
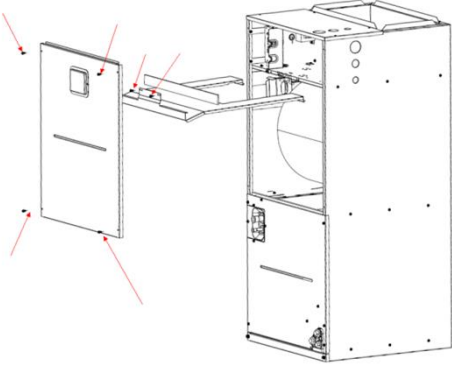
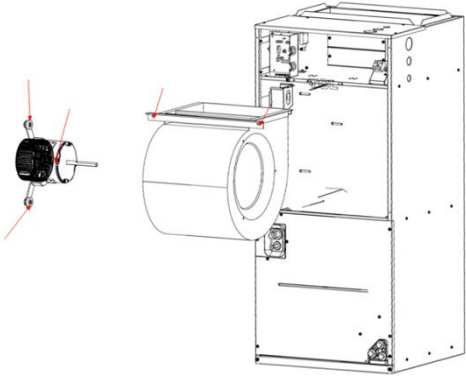
36K inverter top air outlet indoor unit for North America	
Step	2D picture
1. State before disassembly	
State of prototype before disassembly	
2. Disassemble the upper rear side panel and drip tray.	
A. Remove the four screws on the upper rear side panel to remove the upper rear side panel component. B. Remove the two screws on the drip tray to remove it.	
3. Disassemble the blower assembly module and the motor.	
Remove the two screws on the blower assembly module to remove the entire blower module, and then remove the three bolts on the motor to remove the motor from the blower assembly module.	
4. Disassemble the electronic control cover component and internal electronic control module, and remove the control board.	

Remove the four screws on the electronic control cover component to remove the electronic control cover component. Remove the three screws on the internal electrical control module to remove the internal electrical control module, and remove the control board, which is connected to the power mounting panel through a fastener.

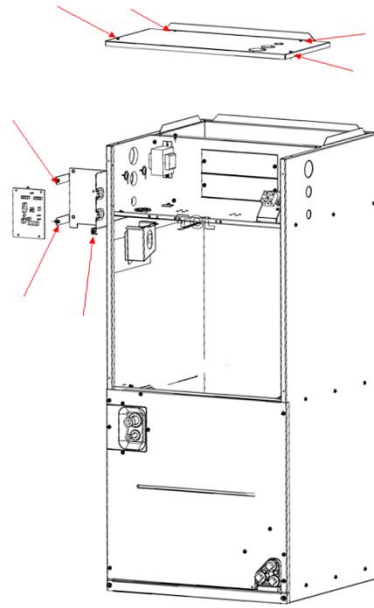

5. Remove the front side panel component and piping cover component.

Remove the nine screws on the front side panel to remove the front side panel, and then remove the one screw on the piping cover plate to remove the piping cover plate.

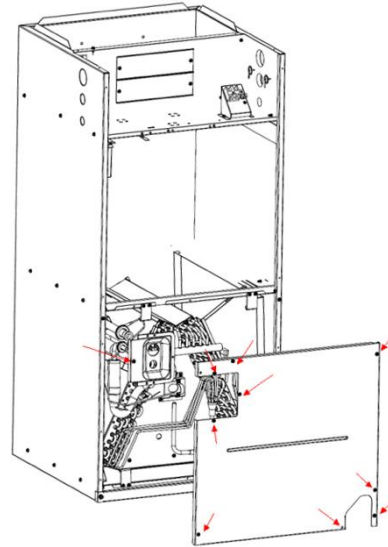

6. Evaporator assembly module

Remove the four screws on the fixing hooks of the two trip trays to remove the two fixing hooks of the trip trays, and draw out the entire evaporator as shown in the picture.

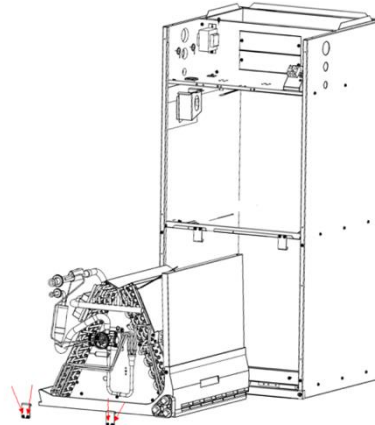

7. Disassemble the refrigerator sensor.

Remove the two screws on both sides of the support bar to remove the support bar, and then remove the one screw on the refrigerant sensor to remove it from the support bar.

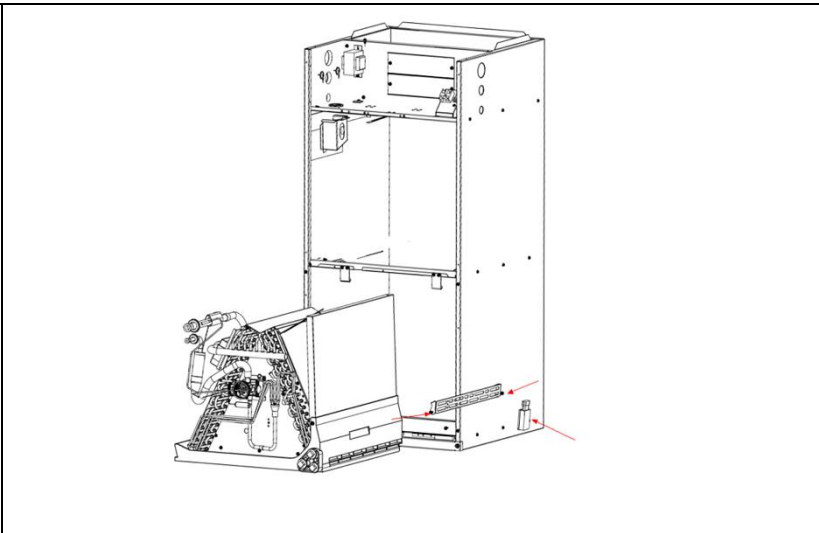

8. Disassemble the electric auxiliary heater.

Remove the four screws on the baffle of the electric auxiliary heater in the direction shown in the picture to remove the electric auxiliary heater.

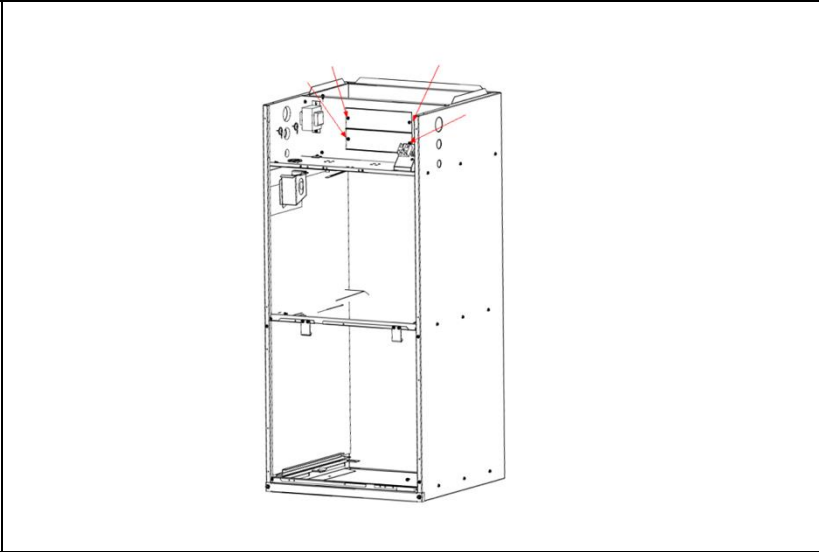

Disassemble of outdoor unit

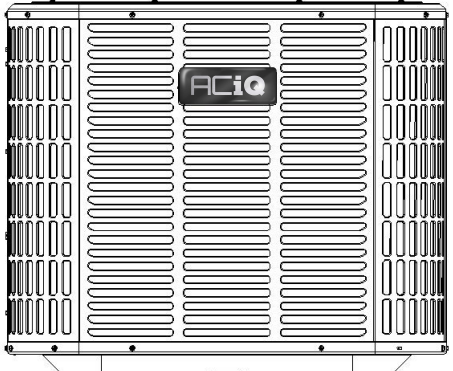
Step	Detailed steps / pictures
Before disassembly	
Step 1: Remove the top cover component, fan blades, and motor.	

Remove the fixing screws from the top cover component to remove the top cover.

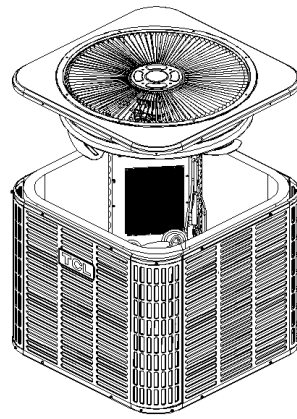

Step 2: Remove the axial flow fan blades and motor.

1) Remove the fixing screws of the axial flow fan blades to remove the axial flow fan blades.

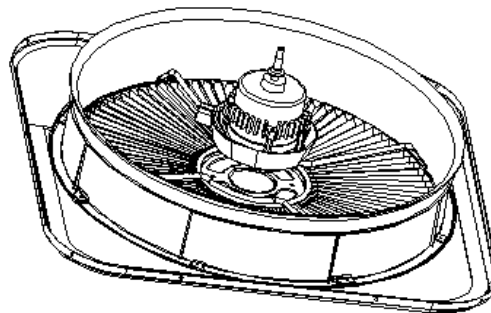
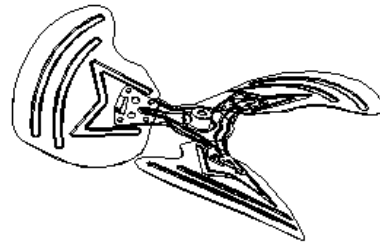

2) Remove the fixing screw of the motor to remove the motor.

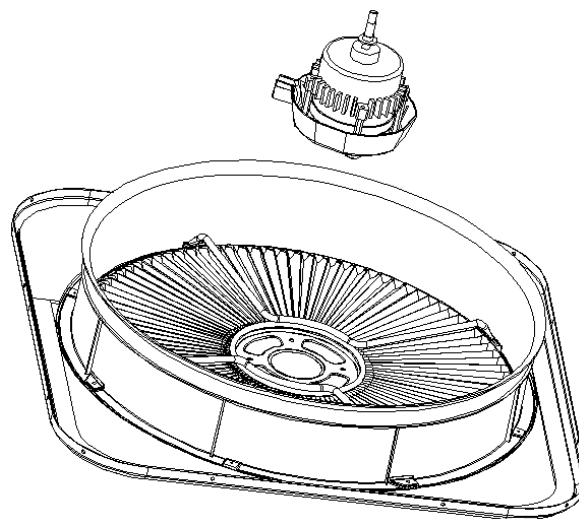

Step 3: Remove the cover plate component of the electric control box and the valve body cover plate.

Remove the fixing screws of the electric control box cover component to remove the electric control box cover.

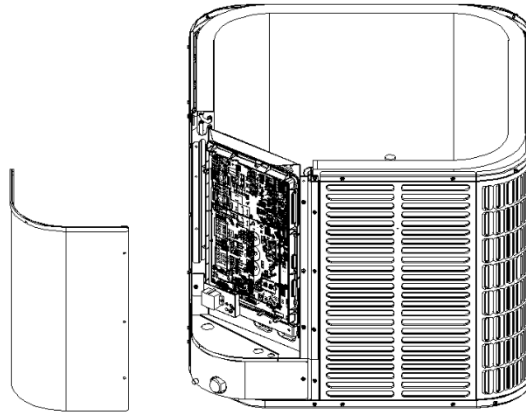

Remove the fixing screws of the valve body cover plate to remove the valve body cover plate.

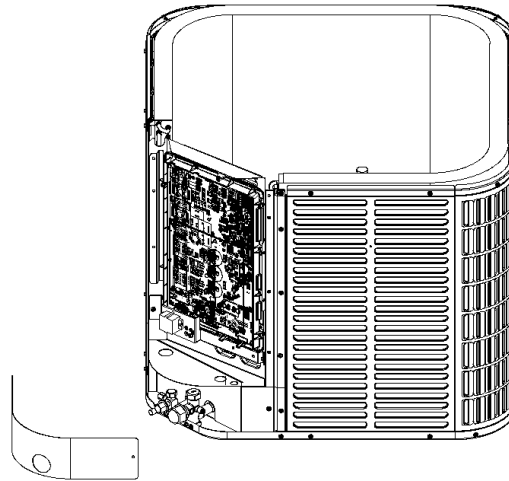

Step 4: Remove side panel 1.

Remove the fixing screws of the side panel to remove side panel 1.

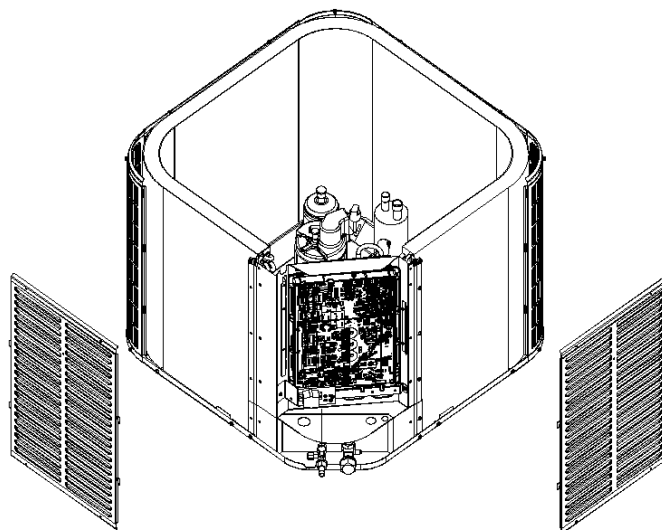

Step 5: Remove the electrical box component.

Remove the fixing screws of the electrical control box component, loosen the cable tie, and unplug the plug to remove the electrical control box.

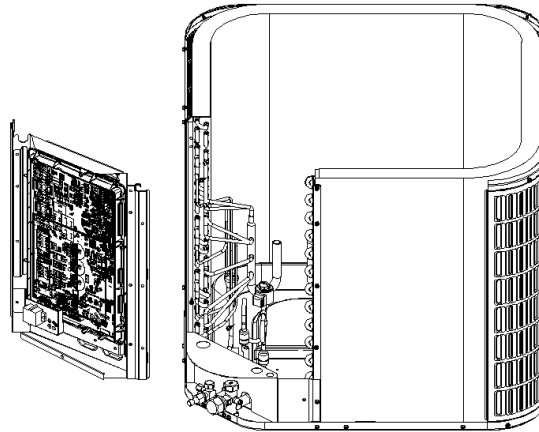

Step 6: Remove the terminal bracket.

Remove the fixing screws of the terminal bracket to remove the terminal bracket.

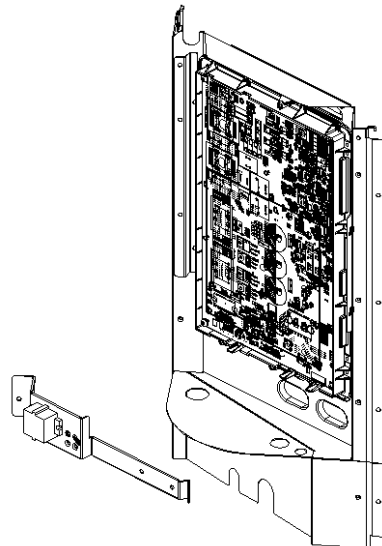

Step 7: Remove the electronic control board.

Remove the fixing screws of the electronic control board to remove the electronic control board.

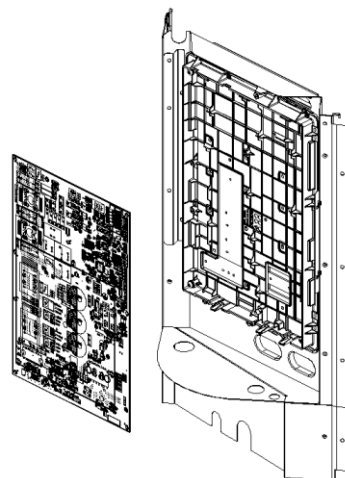

Step 8: Remove the lower side panel.

Remove the fixing screws of the lower side panel to remove the lower side panel.

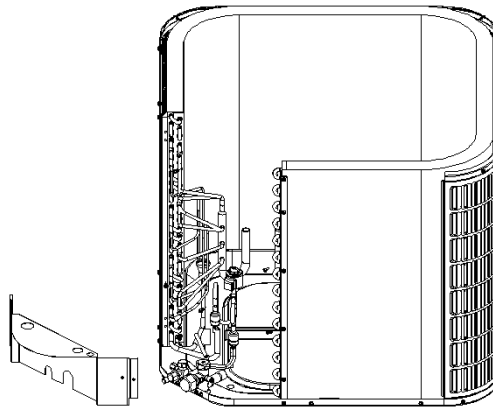

Step 9: Remove the valve.

Remove the valve fixing screws, and then take it out. Before unsoldering, ensure that the refrigerant has been fully discharged. Before unsoldering, fully wrap the valve with damp cloth to prevent high-temperature scalds.

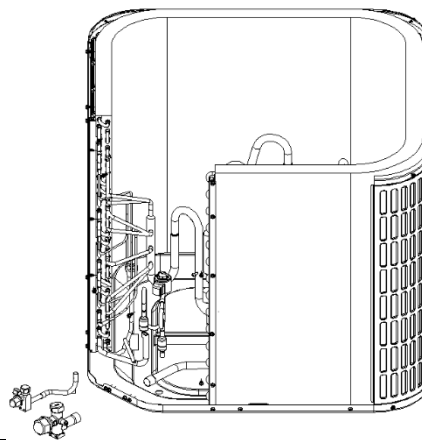

Step 10: Remove the condenser.

Remove the fixing screws at the bottom of the condenser to remove the condenser upwards.

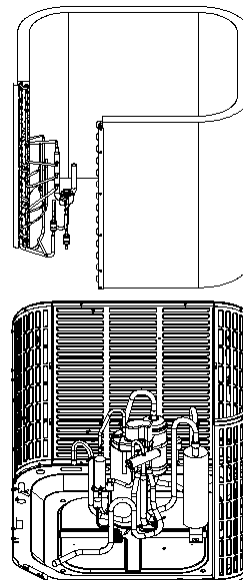

Step 11: Remove the four-way valve component.

Heat the brazing position to loosen the pipeline system. Be careful not to burn out the compressor and nameplate.

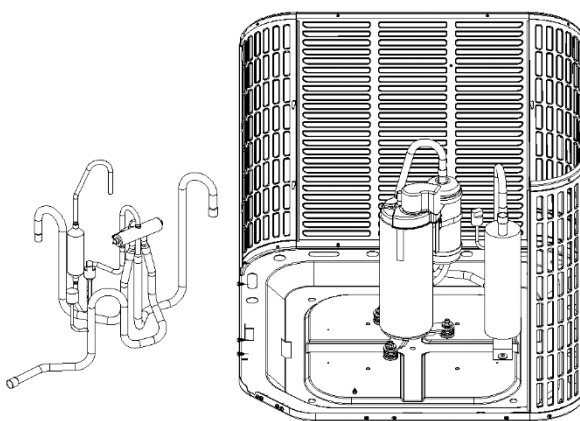

Step 12: Remove the compressor.

Loosen the compressor foot pad bolts to remove the compressor.

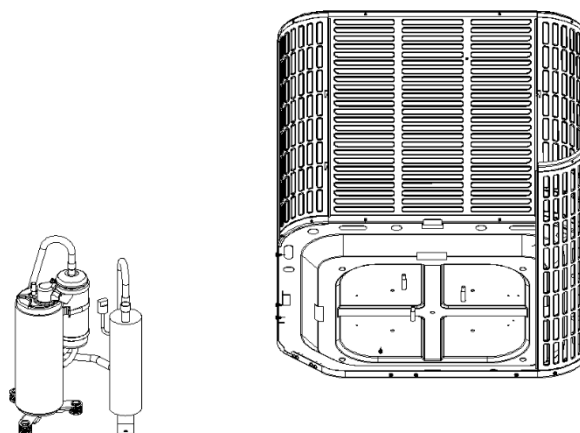

3.3.6 Explosive view and parts list

Exploded view and parts list of indoor unit.

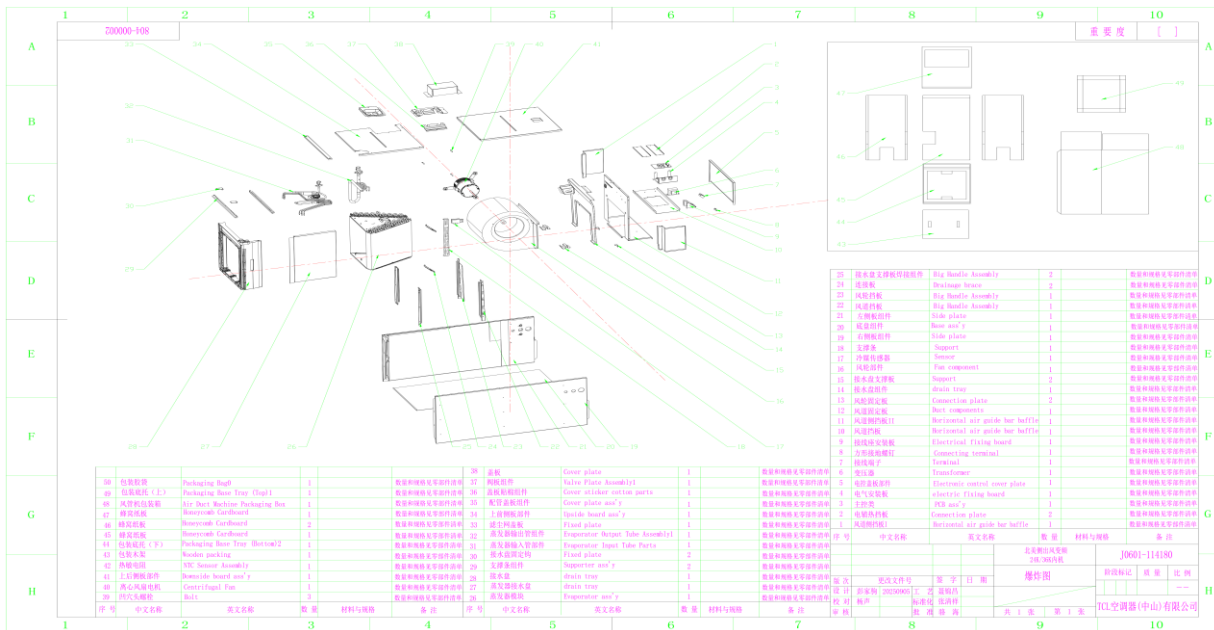

No.	Part No.	Part Name	Q'ty	Remark
1	230803518	Air Duct Side Baffle	1	
2	H0218-111231	Electric Auxiliary Heating Baffle	2	
3	G0301-120213	Main Pcb	1	
4	H0216-111242	Electrical Control Bracket	1	
5	43401-000056	Electric Control Cover Assembly	1	
6	F1101-110020	Transformer	1	
7	11304-100097	Terminal	1	
8	230803113	Square Ground Screw	1	
9	41211-000264	Terminal Block Mounting Plate	1	
10	230803515	Air Duct Top Baffle	1	
11	230803517	Air Duct Side Baffle	1	
12	H0218-111191	Air Duct Fixing Plate	1	
13	H0218-111340	Wind Wheel Fixing Plate	2	
14	/	/	1	
15	43401-000067	Water Tray Support Plate	2	
16	45008-000293	Blower Wheel Component	1	
17	F1004-110036	Gas Sensor	1	
18	43401-000068	Supporter	1	
19	41214-001802	Base Assembly	1	
20	41214-001531	Fan Wheel Water Baffle Welding Assembly	1	

21	41214-001530	Fan Wheel Water Baffle Welding Assembly	1	
22	41214-002386	Drain Pan Tie Rod	2	
23	41214-000066	Drain Pan Support Plate Assembly	2	
24	K0304-114096	Evaporator	1	
25	41102-000277	Drain Pan	1	
26	41308-000018	Water Tray	1	
27	H0218-110448	Left Grille Supporter	2	
28	41214-000262	Water Tray Fixing Hook	2	
29	K0201-113811	Evaporator Input Pipe Assembly	1	
30	K0201-113809	Output Pipe Of Evaporator	1	
31	41214-001811	Dust Filter Cover Plate	1	
32	41214-001804	Upper Front Side Panel Assembly	1	
33	41214-001810	Piping Cover Panel Assembly	1	
34	/	/	0	
35	/	/	0	
36	/	/	0	
37	50702-100069	Socket Head Bolt	3	
38	M0202-110027	Motor	1	
39	43401-000055	Upper Rear Side Plate Assembly	1	
40	G0701-110749	NTC Thermistor	1	
41	L0405-110007	Packaging Wooden Base	1	
42	L0106-110195	Packing Base	1	
43	/	/	0	
44	L0307-110092	Honeycomb Pad Middle	2	
45	L0307-110091	Honeycomb Pad Up	1	
46	L0102-133355	Carton	1	
47	231310589	Packing Bag	1	

36K				
No.	Part No.	Part Name	Q'ty	Remark
1	230803518	Air Duct Side Baffle	1	
2	H0218-111231	Electric Auxiliary Heating Baffle	2	
3	G0301-120213	Main Pcb	1	
4	H0216-111242	Electrical Control Bracket	1	
5	43401-000056	Electric Control Cover Assembly	1	
6	F1101-110020	Transformer	1	

7	11304-100097	Terminal	1	
8	230803113	Square Ground Screw	1	
9	41211-000264	Terminal Block Mounting Plate	1	
10	230803515	Air Duct Top Baffle	1	
11	230803517	Air Duct Side Baffle	1	
12	H0218-111191	Air Duct Fixing Plate	1	
13	H0218-111340	Wind Wheel Fixing Plate	2	
14	/	/	1	
15	43401-000067	Water Tray Support Plate	2	
16	45008-000293	Blower Wheel Component	1	
17	F1004-110036	Gas Sensor	1	
18	43401-000068	Supporter	1	
19	41214-001802	Base Assembly	1	
20	41214-001531	Fan Wheel Water Baffle Welding Assembly	1	
21	41214-001530	Fan Wheel Water Baffle Welding Assembly	1	
22	41214-002676	Drain Pan Tie Rod	2	
23	41214-000066	Drain Pan Support Plate Assembly	2	
24	K0304-114098	Evaporator	1	
25	41102-000277	Drain Pan	1	
26	41308-000018	Water Tray	1	
27	H0218-110448	Left Grille Supporter	2	
28	41214-000262	Water Tray Fixing Hook	2	
29	K0201-113997	Evaporator Input Pipe Assembly	1	
30	K0201-114004	Output Pipe Of Evaporator	1	
31	41214-001811	Dust Filter Cover Plate	1	
32	41214-001804	Upper Front Side Panel Assembly	1	
33	41214-001810	Piping Cover Panel Assembly	1	
34	/	/	0	
35	/	/	0	
36	/	/	0	
37	50702-100069	Socket Head Bolt	3	
38	M0202-110028	Motor	1	
39	43401-000055	Upper Rear Side Plate Assembly	1	
40	10104-100124	NTC Thermistor	1	
41	L0405-110007	Packaging Wooden Base	1	

42	L0106-110195	Packing Base	1	
43	/	/	0	
44	L0307-110092	Honeycomb Pad Middle	2	
45	L0307-110091	Honeycomb Pad Up	1	
46	L0102-133355	Carton	1	
47	231310589	Packing Bag	1	

48K				
No.	Part No.	Part Name	Q'ty	Remark
1	230803336	Air Duct Side Baffle	1	
2	H0218-111231	Electric Auxiliary Heating Baffle	2	
3	G0301-120213	Main Pcb	1	
4	H0216-111243	Electrical Control Bracket	1	
5	43401-000057	Electric Control Cover Assembly	1	
6	F1101-110020	Transformer	1	
7	11304-100097	Terminal	1	
8	230803113	Square Ground Screw	1	
9	41211-000264	Terminal Block Mounting Plate	1	
10	H0218-110040	Air Duct Baffle	1	
11	230803337	Air Duct Side Baffle	1	
12	H0218-111190	Air Duct Fixing Plate	1	
13	H0218-111340	Wind Wheel Fixing Plate	2	
14	/	/	1	
15	43401-000067	Water Tray Support Plate	2	
16	45008-000293	Blower Wheel Component	1	
17	F1004-110036	Gas Sensor	1	
18	/	/	0	
19	H0107-110059	Right Side Plate Assembly	1	
20	H0104-110087	Base Assembly	1	
21	H0107-110058	Left Side Plate Assembly	1	
22	H0218-110013	Air Duct Baffle	1	
23	H0218-110023	Air Duct Baffle	1	
24	H0218-110091	Connection Plate	2	
25	43401-000084	Water Tray Support Plate Welded Assembly	2	
26	K0304-113790	Evaporator	1	
27	H0208-110001	Evaporator Water Tray	1	
28	41308-000019	Water Tray	1	

29	41214-002417	Left Grille Supporter	2	
30	41214-000262	Water Tray Fixing Hook	2	
31	K0201-114624	Evaporator Input Pipe Assembly	1	
32	K0201-114627	Output Pipe Of Evaporator	1	
33	41214-001813	Dust Filter Cover Plate	1	
34	43401-000053	Upper Front Side Panel Assembly	1	
35	41214-001810	Piping Cover Panel Assembly	1	
36	/	/	0	
37	/	/	0	
38	/	/	0	
39	50702-100069	Socket Head Bolt	3	
40	M0202-110029	Motor	1	
41	43401-000054	Upper Rear Side Plate Assembly	1	
42	G0701-110749	Sensor	1	
43	L0402-110021	Packaging Wooden Frame	1	
44	L0106-110162	Packing Base	1	
45	/	/	0	
46	L0307-110088	Honeycomb Pad Right	2	
47	L0307-110059	Honeycomb Cardboard	1	
48	L0102-133348	Carton	1	
49	L0106-110163	Packing Base	1	
50	A2004-000031	Plastic Film	1	

60K				
No.	Part No.	Part Name	Q'ty	Remark
1	230803336	Air Duct Side Baffle	1	
2	H0218-111231	Electric Auxiliary Heating Baffle	2	
3	G0301-120213	Main Pcb	1	
4	H0216-111243	Electrical Control Bracket	1	
5	43401-000057	Electric Control Cover Assembly	1	
6	F1101-110020	Transformer	1	
7	11304-100097	Terminal	1	
8	230803113	Square Ground Screw	1	
9	41211-000264	Terminal Block Mounting Plate	1	
10	H0218-110040	Air Duct Baffle	1	
11	230803337	Air Duct Side Baffle	1	
12	H0218-111190	Air Duct Fixing Plate	1	

13	H0218-111340	Wind Wheel Fixing Plate	2	
14	/	/	1	
15	43401-000067	Water Tray Support Plate	2	
16	45008-000293	Blower Wheel Component	1	
17	F1004-110036	Gas Sensor	1	
18	/	/	0	
19	H0107-110059	Right Side Plate Assembly	1	
20	H0104-110087	Base Assembly	1	
21	H0107-110058	Left Side Plate Assembly	1	
22	H0218-110013	Air Duct Baffle	1	
23	H0218-110023	Air Duct Baffle	1	
24	H0218-110091	Connection Plate	2	
25	43401-000084	Water Tray Support Plate Welded Assembly	2	
26	K0304-113790	Evaporator	1	
27	H0208-110001	Evaporator Water Tray	1	
28	41308-000019	Water Tray	1	
29	41214-002417	Left Grille Supporter	2	
30	41214-000262	Water Tray Fixing Hook	2	
31	K0201-114624	Evaporator Input Pipe Assembly	1	
32	K0201-114627	Output Pipe Of Evaporator	1	
33	41214-001813	Dust Filter Cover Plate	1	
34	43401-000053	Upper Front Side Panel Assembly	1	
35	41214-001810	Piping Cover Panel Assembly	1	
36	/	/	0	
37	/	/	0	
38	/	/	0	
39	50702-100069	Socket Head Bolt	3	
40	M0202-110029	Motor	1	
41	43401-000054	Upper Rear Side Plate Assembly	1	
42	G0701-110749	Sensor	1	
43	L0402-110021	Packaging Wooden Frame	1	
44	L0106-110162	Packing Base	1	
45	/	/	0	
46	L0307-110088	Honeycomb Pad Right	2	
47	L0307-110059	Honeycomb Cardboard	1	
48	L0102-133348	Carton	1	

49	L0106-110163	Packing Base	1
50	A2004-000031	Plastic Film	1

Exploded view and parts list of outdoor unit

Exploded view diagram of an outdoor unit with numbered callouts from 1 to 27. The diagram shows the internal components including the compressor, condenser, fan, and various panels and supports.

序号	中文名称	英文名称	数量	材料/规格	备注
1	顶盖总成	Top cover assembly	1		
2	导流圈	Leading flow circle	1		
3	冷凝器	Condenser	1		
4	电机	Motor	1		
5	保护罩	Protective cover	1		
6	压缩机	Compressor	1		
7	压缩机隔音棉	Compressor soundproof cotton	1		
8	侧板	Side panel	2		
9	冷凝器	Condenser	1		
10	电子膨胀阀总成	Electronic expansion valve assembly	1		
11	高压阀总成	High pressure valve assembly	1		
12	底座总成	Base assembly	1		
13	下侧板	Lower side plate	1		
14	电气控制盒盖板总成	Electrical control box cover plate assembly	1		
15	四通阀总成	4-way valve assembly	1		
16	压缩机	Compressor	1		
17	压缩机隔音棉	Compressor soundproof cotton	1		
18	侧板2	Side panel 2	2		
19	包装箱	Packaging box	1		
20	电气控制盒	Electrical control box	1		
21	电气控制盒盖板	Electrical control box cover	1		
22	电气控制盒盖板总成	Electrical control box cover plate assembly	1		
23	电源线	Power cord	1		
24	电气控制盒	Electrical control box	1		
25	电气控制盒盖板	Electrical control box cover	1		
26	电气控制盒盖板总成	Electrical control box cover plate assembly	1		
27	电气控制盒盖板总成	Electrical control box cover plate assembly	1		

No.	Part No.	Part Name	Q'ty	Remark
1	41207-000829	Top Cover Assembly	1	
2	230700850	Leading Flow Circle	1	
3	25001-000428	Motor	1	
4	45009-000057	Propeller Fan	1	
5	42011-000599	Protective Cover	1	
6	K0401-110043	Compressor Soundproof Cotton	1	
7	K0401-110050	Compressor Soundproof Cotton	1	
8	41214-002094	Side Panel	2	
9	92011-012249	Condenser	1	
10	K0103-110564	Electronic Expansion Assembly	1	
11	92007-021888	High Pressure Valve Assembly	1	
12	H0104-110348	Base Assembly	1	
13	43301-000051	Lower Side Plate	1	
14	43301-000072	Electrical Control Box Cover Plate Assembly	1	
15	K0206-114553	4-Way Valve Assembly	1	
16	92014-000934	Compressor	1	

17	92003-000182	Refrigerant Accumulator	1	
18	43301-000047	Supporter	3	
19	41214-002095	Side Panel	2	
20	231309516	Packaging Carton	1	
21	231310285	Packing Base	1	
22	231305046	Packaging Top Board	1	
23	22007-001394	Compressor Wiring	1	
24	43301-000053	Electric Control Mounting Plate	1	
25	G0301-119688	Outdoor Pcb Assembly	1	
26	11304-100125	Terminal	1	
27	10104-100204	Sensor	1	

36K				
No.	Part No.	Part Name	Q'ty	Remark
1	41207-000829	Top Cover Assembly	1	
2	230700850	Leading Flow Circle	1	
3	25001-000428	Motor	1	
4	45009-000057	Propeller Fan	1	
5	42011-000599	Protective Cover	1	
6	92012-001135	Compressor Soundproof Cotton	1	
7	92012-001102	Compressor Soundproof Cotton	1	
8	41214-002094	Side Panel	2	
9	92011-012365	Condenser	1	
10	K0103-110567	Electronic Expansion Assembly	1	
11	K0103-110489	High Pressure Valve Assembly	1	
12	41202-000662	Base Assembly	1	
13	43301-000051	Lower Side Plate	1	
14	43301-000072	Electrical Control Box Cover Plate Assembly	1	
15	K0206-114858	4-Way Valve Assembly	1	
16	92014-001151	Compressor	1	
17	92003-000182	Refrigerant Accumulator	1	
18	43301-000047	Supporter	3	
19	41214-002095	Side Panel	2	
20	231309516	Packaging Carton	1	
21	231310285	Packing Base	1	
22	231305046	Packaging Top Board	1	

23	22007-001394	Compressor Wiring	1	
24	43301-000053	Electric Control Mounting Plate	1	
25	G0301-119868	Outdoor Pcb Assembly	1	
26	11304-100125	Terminal	1	
27	10104-100204	Sensor	1	

48K				
No.	Part No.	Part Name	Q'ty	Remark
1	41207-000829	Top Cover Assembly	1	
2	230801628	Support Frame	1	
3	230700850	Leading Flow Circle	1	
4	25001-000428	Motor	1	
5	45009-000057	Propeller Fan	1	
6	H1141-110191	Protective Cover	1	
7	K0401-110097	Soundproof Cotton	1	
8	41214-002416	Front Return Air Grille	2	
9	M0102-110135	Compressor	1	
10	K0304-115190	Condenser	1	
11	K0103-110557	Electronic Expansion Assembly	1	
12	K0103-110489	Globe Valve Assembly	1	
13	41202-000789	Base Assembly	1	
14	H0203-110003	Valve Body Cover Plate	1	
15	43301-000075	Electrical Control Box Cover Plate Assembly	1	
16	K0206-114008	4-Way Valve Assembly	1	
17	92001-000003	Electronic Expansion Valve Coil	1	
18	K0206-114012	Suction Pipe	1	
19	231236289	Refrigerant Accumulator	1	
20	43301-000048	Supporter	3	
21	41214-002415	Rear Return Air Grille	2	
22	43301-000062	Support Bracket	1	
23	92009-002126	Connection Tube Assembly 1	1	
24	92009-002129	Connection Tube Assembly 3	1	
25	230701480	Sensor Fixing Clip	1	
26	231310278	Base Support Wooden Frame	1	
27	231310286	Packaging Carton	1	
28	231310285	Packing Base	1	

29	231305046	Packaging Top Board	1	
30	92003-000185	Dry Filter	1	
31	22007-001260	Compressor Wiring	1	
32	43301-000061	Electric Control Mounting Plate	1	
33	45003-000470	Lower Side Plate	1	
34	43301-000067	Terminal Support Bracket	1	
35	G0301-119692	Outdoor Pcb Assembly	1	
36	11304-100125	Terminal	1	
37	10104-100204	Sensor	1	

60K				
No.	Part No.	Part Name	Q'ty	Remark
1	41207-000829	Top Cover Assembly	1	
2	230801628	Support Frame	1	
3	230700850	Leading Flow Circle	1	
4	25001-000428	Motor	1	
5	45009-000057	Propeller Fan	1	
6	H1141-110191	Protective Cover	1	
7	K0401-110097	Soundproof Cotton	1	
8	41214-002416	Front Return Air Grille	2	
9	M0102-110135	Compressor	1	
10	K0304-115190	Condenser	1	
11	K0103-110557	Electronic Expansion Assembly	1	
12	K0103-110489	Globe Valve Assembly	1	
13	41202-000789	Base Assembly	1	
14	H0203-110003	Valve Body Cover Plate	1	
15	43301-000075	Electrical Control Box Cover Plate Assembly	1	
16	K0206-114008	4-Way Valve Assembly	1	
17	92001-000003	Electronic Expansion Valve Coil	1	
18	K0206-114012	Suction Pipe	1	
19	231236289	Refrigerant Accumulator	1	
20	43301-000048	Supporter	3	
21	41214-002415	Rear Return Air Grille	2	
22	43301-000062	Support Bracket	1	
23	92009-002126	Connection Tube Assembly 1	1	
24	92009-002129	Connection Tube Assembly 3	1	
25	230701480	Sensor Fixing Clip	1	

26	231310278	Base Support Wooden Frame	1	
27	231310286	Packaging Carton	1	
28	231310285	Packing Base	1	
29	231305046	Packaging Top Board	1	
30	92003-000185	Dry Filter	1	
31	22007-001260	Compressor Wiring	1	
32	43301-000061	Electric Control Mounting Plate	1	
33	45003-000470	Lower Side Plate	1	
34	43301-000067	Terminal Support Bracket	1	
35	G0301-119694	Outdoor Pcb Assembly	1	
36	11304-100125	Terminal	1	
37	10104-100204	Sensor	1	

3.4 Appendices

3.4.1 Resistance/Temperature Lists of Temperature Sensors

1. Outdoor unit sensor temperature characteristic

TEMP (°F)	R min (kOhm)	R(t) (kOhm)	R max (kOhm)
-22.0	283.3	322.9	367.7
-20.2	267.4	304.4	346.3
-18.4	252.5	287.1	307.4
-16.6	238.5	270.9	307.4
-14.8	225.4	255.7	289.8
-13.0	213.1	241.4	273.3
-11.2	201.5	228	257.9
-9.4	190.6	215.5	243.4
-7.6	180.3	203.6	229.8
-5.8	170.7	192.5	217
-4.0	161.6	182.1	205
-2.2	153.1	172.3	193.7
-0.4	145	163.1	183.2
1.4	137.5	154.4	173.2
3.2	130.3	146.2	163.9
5.0	123.6	138.5	155.1
6.8	117.3	131.3	146.8
8.6	111.3	124.4	139
10.4	105.6	118	131.7
12.2	100.3	111.9	124.7
14.0	95.24	106.2	118.2
15.8	90.49	100.8	112.1
17.6	85.99	95.68	106.3
19.4	81.75	90.86	100.8
21.2	77.74	86.31	95.74
23.0	73.94	82.01	90.88
24.8	70.35	77.95	86.29
26.6	66.96	74.11	81.96
28.4	63.74	70.48	77.87
30.2	60.69	67.05	74.0
32.0	57.81	63.8	70.34
33.8	55.08	60.72	66.88
35.6	52.49	57.81	63.61
37.4	50.03	55.05	60.52
39.2	47.71	52.44	57.59
41.0	45.5	49.97	54.82
42.8	43.41	47.62	52.2
44.6	41.42	45.4	49.71

TEMP (°F)	R min (kOhm)	R(t) (kOhm)	R max (kOhm)
75.2	19.36	20.89	22.52
77.0	18.55	20	21.54
78.8	17.77	19.14	20.6
80.6	17.03	18.32	19.7
82.4	16.32	17.55	18.85
84.2	15.65	16.81	18.04
86.0	15	16.1	17.27
87.8	14.39	15.43	16.54
89.6	13.81	14.79	15.34
91.4	13.25	14.18	15.17
93.2	12.72	13.6	14.54
95.0	12.21	13.05	13.93
96.8	11.72	12.52	13.36
98.6	11.26	12.01	12.81
100.4	10.82	11.53	12.29
102.2	10.29	11.07	11.78
104.0	9.986	10.63	11.31
105.8	9.6	10.21	10.85
107.6	9.231	9.813	10.42
109.4	8.878	9.43	10
111.2	8.54	9.064	9.612
113.0	8.217	8.714	9.233
114.8	7.908	8.38	8.872
116.6	7.612	8.06	8.526
118.4	7.328	7.754	8.196
120.2	7.057	7.461	7.88
122.0	6.797	7.18	7.578
123.8	6.548	6.912	7.289
125.6	6.309	6.655	7.013
127.4	6.08	6.409	6.748
129.2	5.861	6.173	6.495
131.0	5.651	5.947	6.253
132.8	5.449	5.73	6.02
134.6	5.255	5.522	5.798
136.4	5.07	5.323	5.585
138.2	4.891	5.132	5.381
140.0	4.72	4.949	5.101
141.8	4.556	4.774	4.997

TEMP (°F)	R min (kOhm)	R(t) (kOhm)	R max (kOhm)
172.4	2.563	2.654	2.745
174.2	2.481	2.567	2.654
176.0	2.402	2.484	2.567
177.8	2.327	2.404	2.483
179.6	2.254	2.327	2.401
181.4	2.183	2.253	2.323
183.2	2.115	2.182	2.248
185.0	2.05	2.113	2.176
186.8	1.985	2.047	2.109
188.6	1.922	1.983	2.045
190.4	1.861	1.922	1.983
192.2	1.802	1.862	1.923
194.0	1.746	1.805	1.865
195.8	1.692	1.75	1.809
197.6	1.639	1.697	1.755
199.4	1.589	1.646	1.703
201.2	1.54	1.596	1.653
203.0	1.493	1.549	1.604
204.8	1.448	1.502	1.558
206.6	1.404	1.458	1.512
208.4	1.362	1.415	1.469
210.2	1.321	1.373	1.426
212.0	1.284	1.335	1.387
213.8	1.245	1.296	1.348
215.6	1.209	1.258	1.309
217.4	1.173	1.222	1.272
219.2	1.139	1.187	1.236
221.0	1.105	1.153	1.202
222.8	1.073	1.12	1.168
224.6	1.042	1.089	1.136
226.4	1.013	1.058	1.104
228.2	0.9833	1.028	1.074
230.0	0.9553	0.9997	1.045
231.8	0.9283	0.9719	1.016
233.6	0.9021	0.9451	0.9892
235.4	0.8765	0.9191	0.9626
237.2	0.8524	0.894	0.9367
239.0	0.8087	0.8595	0.9117

46.4	39.53	43.2	42.33
48.2	37.74	41.29	45.12
50.0	36.04	39.39	43.01
51.8	34.42	37.59	41
53.6	32.89	35.87	39.1
55.4	31.43	34.25	37.29
57.2	30.04	32.71	35.58
59.0	29.72	31.24	33.95
60.8	28.31	30.72	31.82
62.6	26.87	29.21	30.72
64.4	25.13	27.26	29.55
66.2	24.05	26.07	28.23
68.0	23.02	24.93	26.97
69.8	22.04	23.84	25.77
71.6	21.1	22.81	24.63
73.4	20.21	21.83	23.55

143.6	4.398	4.605	4.817
145.4	4.247	4.448	4.644
147.2	4.101	4.288	4.479
149.0	3.961	4.139	4.32
150.8	3.827	3.995	4.167
152.6	3.698	3.858	4.021
154.4	3.552	3.712	3.883
156.2	3.410	3.692	3.742
158.0	3.339	3.476	3.616
159.8	3.229	3.359	3.491
161.6	3.122	3.246	3.372
163.4	3.02	3.138	3.257
165.2	2.921	3.033	3.146
167.0	2.827	2.933	3.04
168.8	2.735	2.836	2.938
170.6	2.647	2.743	2.84

240.8	0.8059	0.8461	0.8875
242.6	0.7837	0.8233	0.8641
244.4	0.7623	0.8012	0.8413
246.2	0.7415	0.7798	0.8193
248.0	0.7201	0.7581	0.7910
249.8	0.702	0.7386	0.7773
251.6	0.6631	0.7195	0.7572
253.4	0.6649	0.7007	0.7378
255.2	0.6472	0.6824	0.7189
257.0	0.6301	0.6647	0.7006
258.8	0.6135	0.6476	0.6829
260.6	0.5974	0.6309	0.6657
262.4	0.5818	0.6148	0.649
264.2	0.5667	0.5991	0.6328
266.0	0.5521	0.5839	0.6171

R—Resistance

Resistance at 77°F: 20 kΩ

TH3: Outdoor unit discharge pipe sensor

Before measuring resistance, disconnect connectors as shown above.

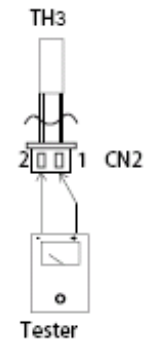

2. Indoor unit sensor temperature characteristics

Temp (°F)	resistance(KΩ)			resist. tolerance %	
	Rmax	R(t)Normal	Rmin	MAX(+)	MIN(-)
-40	122.059	113.858	106.153	7.20	6.77
-38.2	114.913	107.292	100.128	7.10	6.68
-36.4	108.234	101.150	94.488	7.00	6.59
-34.6	101.988	95.402	89.204	6.90	6.50
-32.8	96.145	90.020	84.253	6.80	6.41
-31.0	90.675	84.979	79.611	6.70	6.32
-29.2	85.553	80.254	75.256	6.60	6.23
-27.4	80.754	75.823	71.170	6.50	6.14
-25.6	76.256	71.667	67.333	6.40	6.05
-23.8	72.038	67.766	63.729	6.30	5.96
-22.0	68.080	64.104	60.343	6.20	5.87
-20.2	64.375	60.666	57.157	6.11	5.78
-18.4	60.870	57.413	54.139	6.02	5.70
-16.6	57.579	54.355	51.301	5.93	5.62
-14.8	54.487	51.480	48.630	5.84	5.54
-13.0	51.582	48.776	46.115	5.75	5.46

-11.2	48.850	46.232	43.748	5.66	5.37
-9.4	46.279	43.836	41.517	5.57	5.29
-7.6	43.861	41.581	39.415	5.48	5.21
-5.8	41.585	39.456	37.432	5.40	5.13
-4.0	39.462	37.473	35.581	5.31	5.05
-2.2	37.421	35.565	33.798	5.22	4.97
-0.4	35.519	33.785	32.134	5.13	4.89
1.4	33.725	32.105	30.561	5.05	4.81
3.2	32.033	30.520	29.077	4.96	4.73
5.0	30.437	29.023	27.673	4.87	4.65
6.8	28.931	27.609	26.347	4.79	4.57
8.6	27.508	26.273	25.092	4.70	4.49
10.4	26.165	25.010	23.905	4.62	4.42
12.2	24.896	23.816	22.782	4.53	4.34
14.0	23.697	22.687	21.720	4.45	4.26
15.8	22.562	21.618	20.71	4.37	4.19
17.6	21.490	20.607	19.759	4.29	4.11
19.4	20.475	19.649	18.855	4.21	4.04
21.2	19.515	18.742	17.999	4.13	3.97
23.0	18.606	17.883	17.187	4.05	3.89
24.8	17.745	17.068	16.416	3.97	3.82
26.6	16.930	16.296	15.685	3.89	3.75
28.4	16.156	15.563	14.991	3.81	3.68
30.2	15.423	14.868	14.332	3.73	3.61
32.0	14.792	14.270	13.766	3.66	3.54
33.8	14.069	13.582	13.111	3.58	3.47
35.6	13.443	12.987	12.546	3.51	3.40
37.4	12.849	12.422	12.008	3.43	3.33
39.2	12.284	11.885	11.497	3.36	3.26
41.0	11.749	11.375	11.012	3.29	3.19
42.8	11.239	10.889	10.548	3.22	3.13
44.6	10.756	10.428	10.109	3.15	3.06
46.4	10.295	9.988	9.689	3.08	3.00
48.2	9.858	9.570	9.289	3.01	2.93
50.0	9.441	9.172	8.909	2.94	2.87
51.8	9.044	8.792	8.545	2.87	2.81
53.6	8.667	8.431	8.199	2.80	2.75
55.4	8.308	8.087	7.870	2.74	2.69
57.2	7.965	7.758	7.554	2.67	2.62
59.0	7.639	7.445	7.254	2.61	2.56
60.8	7.329	7.147	6.968	2.54	2.51
62.6	7.032	6.862	6.694	2.48	2.45
64.4	6.749	6.590	6.433	2.42	2.39
66.2	6.480	6.331	6.183	2.36	2.33
68.0	6.223	6.083	5.945	2.30	2.27
69.8	5.977	5.846	5.716	2.23	2.22

71.6	5.742	5.620	5.498	2.18	2.16
73.4	5.518	5.404	5.290	2.12	2.11
75.2	5.305	5.198	5.091	2.06	2.05
77.0	5.100	5.000	4.900	2.00	2.00
78.8	4.909	4.811	4.713	2.05	2.04
80.6	4.727	4.630	4.533	2.09	2.09
82.4	4.552	4.457	4.36	2.14	2.13
84.2	4.386	4.292	4.199	2.18	2.17
86.0	4.225	4.133	4.042	2.23	2.21
87.8	4.072	3.982	3.892	2.27	2.25
89.6	3.925	3.836	3.748	2.31	2.29
91.4	3.784	3.697	3.611	2.36	2.33
93.2	3.649	3.564	3.479	2.40	2.37
95.0	3.520	3.436	3.353	2.44	2.41
96.8	3.395	3.313	3.232	2.48	2.45
98.6	3.275	3.195	3.116	2.52	2.49
100.4	3.161	3.082	3.004	2.56	2.52
102.2	3.051	2.974	2.898	2.60	2.56
104.0	2.946	2.870	2.795	2.64	2.60
105.8	2.844	2.770	2.697	2.68	2.63
107.6	2.748	2.675	2.604	2.71	2.67
109.4	2.654	2.583	2.513	2.75	2.71
111.2	2.564	2.494	2.426	2.79	2.74
113.0	2.478	2.410	2.343	2.83	2.78
114.8	2.395	2.328	2.263	2.86	2.81
116.6	2.315	2.250	2.186	2.90	2.84
118.4	2.238	2.174	2.111	2.93	2.88
120.2	2.164	2.102	2.041	2.97	2.91
122.0	2.093	2.032	1.972	3.01	2.95
123.8	2.025	1.965	1.906	3.04	2.98
125.6	1.959	1.901	1.844	3.07	3.01
127.4	1.896	1.839	1.783	3.11	3.04
129.2	1.835	1.779	1.724	3.14	3.07
131.0	1.776	1.721	1.668	3.18	3.11
132.8	1.719	1.666	1.614	3.21	3.14
134.6	1.665	1.613	1.562	3.24	3.17
136.4	1.613	1.562	1.512	3.27	3.20
138.2	1.562	1.512	1.463	3.31	3.23
140.0	1.514	1.465	1.417	3.34	3.26
141.8	1.467	1.419	1.372	3.37	3.29
143.6	1.42	1.374	1.328	3.40	3.32
145.4	1.378	1.332	1.287	3.43	3.35
147.2	1.334	1.291	1.247	3.46	3.38
149.0	1.295	1.25	1.208	3.49	3.41
150.8	1.256	1.213	1.17	3.52	3.43
152.6	1.218	1.176	1.135	3.55	3.46

154.4	1.181	1140	1.100	3.58	3.49
156.2	1.146	1.106	1.067	3.61	3.52
158.0	1.112	1.073	1.035	3.64	3.55
159.8	1079	1.041	1.004	3.67	3.57
161.6	1.045	1.010	0.974	3.70	3.60
163.4	1.016	0.980	0.944	3.72	3.63
165.2	0.988	0.952	0.917	3.75	3.65
167.0	0.959	0.924	0.890	3.78	3.68
168.8	0.931	0.897	0.864	3.80	3.71
170.6	0.904	0.87	0.839	3.83	3.73
172.4	0.879	0.846	0.814	3.86	3.76
174.2	0854	0.82	0.79	3.88	3.78
176.0	0.830	0.799	0.769	3.91	3.81
177.8	0.807	0.776	0.746	3.94	3.83
179.6	0.784	0.754	0725	3.96	3.85
181.4	0.762	0.733	0.705	3.99	3.88
183.2	0742	0.713	0.685	4.0	3.90
185.0	0.721	0.693	0.666	4.03	3.92
186.8	0.70	0.674	0647	4.06	3.95
188.6	0.682	Q.655	0.629	4.08	3.97
190.4	0.664	0.638	0.613	4.10	3.99
192.2	0.646	0.620	0.595	4.13	4.01
194.0	0.629	0.604	0.580	4.15	4.03
195.8	0.611	0.587	0.563	4.17	4.05
197.6	0.596	0.572	0.549	4.19	4.07
199.4	0.580	0.557	0.534	4.21	4.09
201.2	0.565	0.542	0.520	4.23	4.11
203.0	0.550	0.528	0.506	4.25	4.13
204.8	0.536	0.514	0.493	4.27	4.15
206.6	0.522	0.501	0.480	4.29	4.17
208.4	0.50g	0.488	0.468	4.31	4.18
210.2	0.491	0.476	0.456	4.33	4.20
212.0	0.48	0.464	0.444	4.34	4.22
213.8	0.472	0.452	0.433	4.36	4.23
215.6	0.460	0441	0.422	4.38	4.25
217.4	0.449	0.430	0.412	4.39	4.26
219.2	0.43	0419	0.401	4.41	4.28
221.0	0.427	0.409	0.391	4.42	4.29
222.8	0.416	0.399	0.381	4.44	4.31

3.4.2 Temperature / Pressure list of Refrigerant

	24K			36K			60K		
	f(Hz)	HP (PSI)	LP (PSI)	f(Hz)	HP (PSI)	LP (PSI)	f(Hz)	HP (PSI)	LP (PSI)
35°C (95°F) Cooling	72	423.5	134.9	76	380.0	118.9	84	442.4	110.2
43°C (109.4°F) Cooling	66	481.5	152.3	70	436.6	126.2	72	490.2	121.8
48°C (118.4°F) Cooling	54	507.6	165.3	64	475.7	156.6	64	538.1	146.5
7°C (44.6°F) Heating	72	319.1	94.3	86	345.2	87.0	86	433.7	88.5
20°C (68°F)Heating	60	293.0	100.1	74	390.2	113.1	70	365.5	105.9
Rated Cooling	52	387.3	146.5	72	372.7	123.3	84	442.4	110.2
Rated Heating	66	310.4	95.7	74	358.2	88.5	76	348.1	81.2

NOTE

The test under condition:

Rated Cooling: IDU dry bulb 80°F/ Wet bulb 66.9°F, ODU dry bulb 95°F/ wet bulb 75°F; The connection pipes: 25ft.

Rated Heating: IDU dry bulb70°F/ Wet bulb 60°F, ODU dry bulb 47°F/ wet bulb 43°F; The connection pipes: 25ft.

IMPORTANT

The above data under test standard in the lab, the HP (High pressure) and LP (Low pressure) will vary along with the variation of operation frequency, ambient temperature and/or fan speed.

3.4.3 Operation tools

The following tools will be used:

- 1) Liquid-level gauge;
- 2) Screwdriver;
- 3) Electric driven rotary hammer;
- 4) Drill;
- 5) Pipe expander;
- 6) Torque wrench;
- 7) Open-end wrench;
- 8) Pipe cutter;
- 9) Leak detector;
- 10) Vacuum pump;
- 11) Pressure gauge;
- 12) Universal meter;
- 13) Hexagon wrench;
- 14) Tapeline.

4. Parameter query

When the unit is turned ON or OFF (stand-by), you can query the unit parameter through the operation panel of the **wired controller**.

4.1 Operation and display

4.1.1 The way to enter the parameter query

When the unit is on the states of turned ON or OFF, press the buttons **[FAN] + [Λ]** for 5S at the same time, the control panel will enter the parameter query interface, the **parameter code** will be displayed in the **Timer area** of the panel, and flashing meantime.

4.1.2 Switch parameter codes

Change the parameter code by pressing the **[Λ]** and/or **[V]** key.

The level of parameter code			Query the current parameter		Scope of query	Remark
parameter Code	Display area	Name of parameter code	Query value	Display area		
00	Timer area	Number of indoor units connect to the wired controller.	Current value	Timer area--minute	00~80	AHU --Not available
01	Timer area	Room temperature (°F/°F)	Current value	Temp. area	-30~150	When unit displays the temperature in Celsius, the unit is in Celsius. When displays the temperature in Fahrenheit, the unit is in Fahrenheit.
02	Timer area	Wired controller tested temperature (°F/°F)	Current value	Temp. area	-30~150	When unit displays the temperature in Celsius, the unit is in Celsius. When displays the temperature in Fahrenheit, the unit is in Fahrenheit.
03	Timer area	Time for filter cleaning.	Current value	Timer area--minute		
04	Timer area	The expansion valve opening of the checked indoor unit.(PLS)	Current value	Temp. area	0~500	
05	Timer area	The evaporator inlet temperature of the checked indoor unit.(°F/°F)	Current value	Temp. area	-30~150	When unit displays the temperature in Celsius, the unit is in Celsius. When displays the temperature in Fahrenheit, the unit is in Fahrenheit.
06	Timer area	The evaporator mid-side temperature of the checked indoor unit.(°F/°F)	Current value	Temp. area	-30~150	
07	Timer area	The evaporator outlet temperature of the checked indoor unit.(°F/°F)	Current value	Temp. area	-30~150	
08	Timer area	The rated capacity of the checked indoor unit.(HP)	Current value	Timer area--minute		
09	Timer area	Current capacity requirements of the checked indoor unit.(HP)	Current value	Timer area--minute		
10	Timer area	The project No of the checked indoor unit.	Current value	Temp. area		
11	Timer area	IP address of the checked indoor unit.	Current value	Temp. area		
12	Timer area	TVOC value	Current value	Temp. area		
E1	Timer area	History of failure 1	Err +**	Temp. area		Err1 is the earlier fault ,and Err 5 is the latest fault
E2	Timer area	History of failure 2	Err +**	Temp. area		
E3	Timer area	History of failure 3	Err +**	Temp. area		
E4	Timer area	History of failure 4	Err +**	Temp. area		
E5	Timer area	History of failure 5	Err +**	Temp. area		
17	Timer area	Version of the wire controller software	Current value	Temp. area		Vxx
18	Timer area	Room temp of the checked indoor unit. (°F/°F)	Current value	Temp. area	-30~150	
19	Timer area	Number of dial codes of checked indoor unit.	Current value	Temp. area	0~FF	Shown in hexadecimal
20	Timer area	Fan speed of the checked indoor unit. (rpm)	Current value	Temp. area	0~1500	Display at 1/10 of the actual speed, such as 1236 shows 124
21	Timer area	The concentration value of refrigerant leakage sensor detects (%)	Current value	Temp. area	0~100	Display the actual value.
22	Timer area	Version of software the checked indoor unit.	Current value	Temp. area		
23	Timer area	ODU ambient temp. (°F/°F)	Current value	Temp. area	-30~150	When unit displays the temperature in Celsius, the unit is in Celsius. When displays the temperature in Fahrenheit, the unit is in Fahrenheit.
24	Timer area	ODU pipe temp. (°F/°F)	Current value	Temp. area	-30~150	

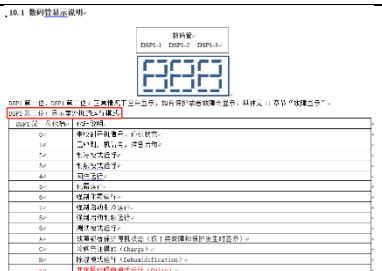







25	Timer area	ODU liquid line temp. (°F/°F)	Current value	Temp. area	-30~150	When the temperature is negative, the integer part is displayed and blinked only.
26	Timer area	ODU Exhaust temp. (°F/°F)	Current value	Temp. area	-30~150	When the temperature is 100 to 109, it shows A0 to A9
27	Timer area	ODU IPM temp. (°F/°F)	Current value	Temp. area	-30~150	When the temperature is 110 to 119, it shows B0 to B9 When the temperature is 120~129, it shows C0~C9
28	Timer area	Compressor frequency (Hz)	Current value	Temp. area	0~160	Display: The actual value dividing by 10
29	Timer area	ODU fan speed (rpm)	Current value	Temp. area	0~1500	Display: The actual value dividing by 10
30	Timer area	ODU EEV opening (P)	Current value	Temp. area	0~500	Display: The actual value dividing by 10
31	Timer area	ODU current (A)	Current value	Temp. area	0~99	Display the actual value.
32	Timer area	Compressor current (A)	Current value	Temp. area	0~99	Display the actual value.
33	Timer area	ODU AC voltage (V)	Current value	Temp. area	0~500	Display the actual value.
34	Timer area	ODU bus bar voltage (V)	Current value	Temp. area	0~500	Display: The actual value dividing by 10
35	Timer area	ODU operation status.	Current value	Temp. area		Refer to ODU function manual. 
36	Timer area	Fault inquiry	Current value	Temp. area	Failure code	









Note : the codes “18 ~ 36” for some of units only.

















4.1.3. Exit parameter query

1. In the state of parameter query, press the **[Mode]** key at any time to exit the query.
2. In the state of parameter query, press the  key at any time to exit the query
3. While in the process of parameter query, no operation within 15 seconds will exit the query state and return to the main interface.

4.2 Indoor unit PCB dial codes.



SW1		
DIP bit	Setting	Function instruction
SW1-1		Default. High fan speed torque value [TOR_H] , low fan speed [TOR_L] refers to the value of EEPROM.
	ON 	The torque value of high and low fan speed is subject to the gear of the dip switch (The factory default value: subject to the actual dial code of the model)
SW1-2 & SW1-3)		The low fan speed runs with the torque of [TOR_{medium speed}] ; The high fan speed runs at the torque of [TOR_{strong wind}]
		The low fan speed runs with the torque of [TOR_{medium and low fan}] ; The high fan speed runs with the torque of the [TOR_{high speed wind}]
		The low fan speed runs at the torque of [TOR_{low speed wind}] ; The high fan speed runs at the torque of [TOR_{medium and high wind}]
		Low fan speed runs with [TOR_{silent wind speed}] torque; The high fan speed runs at the torque of [TOR_{medium speed wind}]
SW1-4		Default. The 24V control mode has the function of cold air preventing.
	ON 	The 24V control mode without cold air preventing function.





SW2		
DIP bit	Setting	Function instruction
SW2-1		Default.--24V control mode. SW1 dial function is effective, the 485 communication btw the wired controller and IDU PCB is invalid.
	ON 	485 Control. SW1 dial function is invalid, 485 communication btw the wired controller and IDU PCB is effective, the 485 communication btw indoor and outdoor unit is subject to the ODU dip code
SW2-2		Default. When the unit is not installed with the lower air outlet, the fan speed and/or electric auxiliary heater are controlled according to the conventional logic
	ON 	The fan speed and electric auxiliary heater are controlled according to special logic when the unit is installed with lower air outlet
SW2-3		Default. Electric auxiliary heater is controlled according to the temperature of the IDU air outlet (effective only under the control of 24V)
	ON 	Electric auxiliary heater is NOT controlled according to the temperature of the IDU air outlet (effective only under the control of 24V)
SW2-4		Aside
	ON 	Aside

SW2		
DIP bit	Setting	Function instruction
SW3-1		R32 Refrigerant sensor
	ON 	Default. R32 Refrigerant sensor
SW3-2 SW3-3	   Digital 2 3	24K
	   Digital 2 3	36K
	   Digital 2 3	48K
	   Digital 2 3	60K
SW3-4		Aside
	ON 	Aside

Note 1 : The dip switch only detects the status of the main control board once when it is powered on, and no longer detects it after it is powered on.

4.3 Outdoor unit PCB dial codes.

SW1		
DIP bit	Setting	Function instruction
SW1-1	ON 	AC outdoor unit
		HP outdoor unit

SW1-2		Lower capacity
		Normal capacity
SW1-3& SW1-4)		485 communication
		24V ON/OFF control

ACCIO

The design and specifications are subject to change without prior notice for product improvement. Consult with the sales agency or manufacturer for details. Any updates to the manual will be uploaded to the service website, please check for the latest version.