

TropiCal™

Installation/Operation Manual



PoolSync® Ready Equipment

T70, T100, and T130

NOTE ON CERTIFICATIONS:

Manufacture's model numbering to be used throughout this document will be as shown as T70, T100, and T130. These models are certified under the model numbers as shown below:

TropiCal FGIVN-070 IVA15Q0 (T70) / TropiCal FGIVN-100 IVA24Q0 (T100) / TropiCal FGINV-130 IVA28Q0 (T130)



Important

Read this document before operating / installing this product

For additional product manuals and operation / installation procedures, please visit www.AquaCal.com

MODEL / SERIAL NUMBER

Table of Contents

Contacting AquaCal AutoPilot, Inc.	1
Safety	2
1 - Flammable Refrigerant	7
2 - Installation	13
2.1 Transporting Equipment	13
2.2 Positioning Equipment	14
2.3 Plumbing	17
2.3.A Plumbing Requirements	17
2.3.B Maintaining Ability to Winterize	17
2.3.C Water Connections to Heat Pump	18
2.3.D In-Line Chlorine Feeders	19
2.3.E Water Flow Rates	20
2.4 Electrical	20
2.4.A Electrical Requirements	20
2.4.B Schematics	21
2.4.C Access Panels	21
2.4.D Incoming Power Access Holes	22
2.4.E Connection Points	23
2.4.F Circulation Pump's Connection Point	24
2.4.G Connecting an External (2-wire Dry Contact) Controller	25
2.5 Installer Start Up Check List	26
3 - Operation	27
3.1 Control Panel	27
3.2 Programming	28
3.2.A Activating / Deactivating the Heat Pump	29
3.2.B Setting a desired water temperature setpoint	29
3.2.C Selecting Celsius or Fahrenheit	30
3.2.D Activate HEAT Mode, COOL Mode, or AUTO Mode	30
3.2.E Set Efficiency Mode	32
3.2.F Setting Heat Pump Time of Day	33
3.2.G Entry Lock Option	34
3.3 Optional Programming	36
3.3.A The TropiCal® Heat Pump using WiFi	36
3.3.B Programming for Circulation Pump Extend Mode	37
4 - Appendix	38
4.1 Service	38
4.1.A Service Personnel Qualifications	38
4.1.B Servicing Procedures	39
4.1.C Service Help	41
4.1.D Disposal of Heat Pump	42
4.2 Adjustments	43
4.2.A Cleaning Equipment	43
4.2.B Keeping the Filtration System Clean	44
4.2.C Maintenance	45
4.2.D Water Flow Adjustment Procedure	46

4.3 Supplemental	47
4.3.A Irrigation and Storm Run-Off	47
4.3.B Heating the water for the first time	47
4.3.C Pool Blankets	48
4.3.D Liquid Blankets	48
4.3.E Cooling the water for the first time	48
4.3.F Standards	49
4.3.G FCC Compliance	49
4.3.H Winterizing	50
4.4 System Information	52
4.4.A Dimensions	52
4.4.B Weights	53
4.4.C Identifying Model Specifications	53
4.4.D Operating Temperatures	54
5 - Troubleshooting -----	55
5.1 Fault Codes	57
5.2 Issues and Resolutions	65

Contacting AquaCal AutoPilot, Inc.

For further assistance, please contact the distributor or installer of this product.

If unavailable, please contact AquaCal® for a partner in your area. To better assist you, please have the heat pump model and serial number available.

It will also be helpful to have the following information available when requesting service:

- What is the pressure reading on the gauge (manometer) on the back of the machine when the system is inactive (off).
- If the system will operate, what is the reading on the pressure gauge (manometer) on the back of the machine after three minutes.
- The position of the ON / OFF button and if it is lit or not.
- The indicator values displayed on the digital controller. *(See page 28 for more information)*
- The value of programmed settings. *(See page 32 for more information)*
- If fan is working or not.
- Position of the by-pass valves.
- The dimensions of the swimming pool.
- The description of the failure.

Product Information:

Website	www.AquaCal.com
Manuals	https://www.aquacal.com/heatpump-manuals/
Phone	(1) 727-823-5642
Hours	8-5 pm, Eastern M-F

Service Information:

Website	www.AquaCal.com/heat-pump-service/
Phone	(1) 727-823-5642

Additional product specific installation advice is available online in the manuals section.

<https://www.aquacal.com/heatpump-manuals/>



SAFETY

- For personal safety, and to avoid damage to equipment, follow all safety instructions displayed on the equipment and within this manual. Repair and service of heat pump must be performed by an authorized service center.
- Warranties may be voided if the equipment has been improperly installed, maintained or serviced.
- If the issue persists, please contact the installing dealer for service.

SAFETY SIGNALS

Throughout this document, safety signals have been placed where particular attention is required.



Refrigerant Safety
Group A2L

Flame Symbol and A2L Refrigerant

Failure to heed the following may result in injury or death.

⚠ DANGER

Failure to heed the following will result in injury or death.

⚠ WARNING

Failure to heed the following may result in injury or death.

NOTICE

Failure to heed the following may result in damage to equipment.

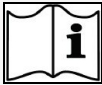

This signal will show that the section is Operation Instructions.



This signal will show that the section suggests Reading the Operator's Manual.



This signal will show that the section is information on Servicing the equipment.



This signal depicts a barred waste bin indicating the product must not be discarded alongside household waste. It must be brought to an adequate collection point where electronic appliances are recycled (information available from your local waste treatment service). This product contains potentially hazardous substances.

When installing and using your heat pump basic safety precautions must always be followed, including the following:



Refrigerant Safety
Group A2L

Failure to heed the following may result in injury or death.

- THIS EQUIPMENT CONTAINS SEMI-FLAMMABLE REFRIGERANT. Read the section entitled "FLAMMABLE REFRIGERANT" before servicing / installing this equipment. See "*Flammable Refrigerant*" on page 7.
- Do not pierce or burn the appliance.
- Be aware that refrigerants may not contain an odor. If a refrigerant leak is present, it may not be immediately obvious and can either displace breathable air or become a source for a fire.
- The R32 is a refrigerant of category A2L per ISO 817, which is considered as potentially flammable.
- Do not release R32 refrigerant into the atmosphere. This refrigerant is a greenhouse effect fluorinated gas, covered by the Kyoto Protocol, with a global warming potential (GWP) = 675 for R32.
- Do not use a means to accelerate the defrosting process or to clean the equipment, other than what is recommended by the manufacturer.
- Install the unit outdoors. Do not install the unit indoors or in an outdoor area that is closed and poorly ventilated.
- If stored, the appliance shall be stored in a room without continuously operating ignition sources (for example: open flames, an operating gas appliance or an operating electric heater).
- To comply with the relevant standards and regulations in terms of the environment and installation procedures, and in particular with decree Number 2015-1790 and / or European regulation EU 517/2014, a search for leaks of the cooling circuit must be conducted at least once a year. This operation should be carried out by a certified specialist of cooling devices.
- Please keep and transfer these documents for reference throughout the lifespan of the device, And please save these instructions.

DANGER

Failure to heed the following will result in injury or death.

- The heat pump utilizes high voltage and rotating equipment. Use caution when servicing.
- Prior to installing and servicing the equipment, ensure that power has been deactivated, and a lockout-tag out procedure has been performed.
- RISK OF ELECTRICAL SHOCK FROM ENERGY STORED IN CAPACITORS - MODELS EQUIPPED WITH VARIABLE FREQUENCY COMPRESSOR DRIVES STORE ELECTRICITY EVEN AFTER THE POWER HAS BEEN DEACTIVATED AT THE POWER BREAKER. **Wait for 2 minutes after the shut down of equipment before servicing.**
- Follow all National Electric Codes (NEC) and / or State and Local guidelines.
- Heat Pump equipment must be installed according to manufacturer's instructions and specifications and must follow all National and / or State and Local installation guidelines. The manufacturer will not be liable in case of non-compliance with the installation standards that apply locally.
- Handling, installation, cleaning, servicing and / or disposal of the refrigerant can only be done by a person with the proper qualifications (EPA or equivalent licensing).
- For any action, other than simple maintenance operations by the user as described in this manual, the product should be maintained by a certified professional.
- Moving parts can cause severe injury or death. Do not touch the fan or the moving parts, and do not insert objects or your fingers close to the moving parts when the device is operating.
- Do not pull on hoses and / or connections to move the machine.
- Follow all instructions for installation and usage in this manual in order to prevent injury or death.

WARNING

Failure to heed the following may result in injury or death.

- Installation and repairs must be performed by a qualified technician possessing the adequate technical skills (electricity, hydraulic, refrigeration) in order to undertake maintenance operations or repairs on the device.
- A qualified technician working on the device must use / wear personal protective equipment (safety goggles, protection gloves, etc.) in order to avoid risk of injury during work on the device.
- The Heat Pump contains refrigerant under pressure. Repairs to the refrigerant circuit must not be attempted by untrained and / or unqualified individuals. Service must be performed only by qualified HVAC technicians. Recover refrigerant before opening the system.
- Improper water chemistry can present a serious health hazard. To avoid possible hazards, maintain pool / spa water per standards as detailed in the product's operation manual.
- Sudden or prolonged immersion in water warmer than normal body temperature may cause a condition known as Hyperthermia and related injuries.
 - Hyperthermia occurs when the internal temperature of the body reaches a level several degrees higher than the normal body temperature of 98.6° F (37° C).
 - The symptoms of Hyperthermia include, but are not limited to, a failure to perceive heat, slurred speech or mumbling, slow, shallow breathing, weak pulse, clumsiness, drowsiness or low energy level, confusion, poor decision-making, lack of concern about personal welfare; progressive loss of consciousness resulting in danger of drowning.
 - The effects of Hyperthermia include failure of the nervous system, respiratory system and heart; failure to recognize the need to exit spa; unawareness of impending hazard; physical inability to exit the spa; progressive loss of consciousness resulting in danger of drowning.
 - Persons having an adverse medical history. or pregnant women, should consult a physician before immersing in a warm body of water. Children and the elderly should be supervised by a responsible adult.
 - When pregnant, soaking in warm water for long periods of time can harm the fetus.
 - The use of alcohol, drugs, or medication can greatly increase the risk of fatal Hyperthermia.
 - Exit immediately if uncomfortable, dizzy, or sleepy.

- Sudden or prolonged immersion in water colder than normal body temperature may cause a condition known as Hypothermia and related injuries.
 - Hypothermia occurs when the internal temperature of the body reaches a level several degrees below the normal body temperature of 98.6° F (37° C).
 - The symptoms of Hypothermia include, but are not limited to, shivering (although as hypothermia worsens, shivering stops), slurred speech or mumbling, slow, shallow breathing, weak pulse, clumsiness, drowsiness or low energy level, confusion, poor decision-making, lack of concern about personal welfare, unconsciousness, and bright red, cold skin (in infants).
 - The effects of Hypothermia include failure of the nervous system, respiratory system and heart; failure to recognize the need to exit spa or cold plunge; unawareness of impending hazard; fetal damage in pregnant women; physical inability to exit the spa or cold tub; progressive loss of consciousness resulting in danger of drowning.
 - Persons having an adverse medical history, or pregnant women, should consult a physician before immersing in a cold body of water. Children and the elderly should be supervised by a responsible adult.
 - When pregnant, soaking in cold water for long periods of time can harm the fetus.
 - The use of alcohol, drugs, or medication can greatly increase the risk of fatal Hypothermia.
 - Exit immediately if uncomfortable, dizzy, shivering, or sleepy.
- This appliance is not to be used by individuals (including children) with reduced physical, sensory, or mental capabilities, or lack of experience and knowledge, unless they have been given supervision or instruction by a person responsible for their safety.
- Children must be supervised and are not to play with the appliance.
- The information contained in this section is intended for use by qualified electricians familiar with electrical Service-industry safety standards and methods.
- Locate the equipment disconnect as near to the heat pump as possible. Always satisfy applicable codes and standards.
- Never mount power-disconnects directly to the heat pump.
- In sizing power wiring, be especially aware of up-sizing requirements necessary due to wiring distances. Always satisfy applicable codes and standards.
- Please check equipment data plate for breaker sizing. If local codes require a GFCI be installed, confirm it has a minimum current leakage rating of 20 mA.
- AquaCal AutoPilot, Inc. heat pumps are designed to use copper conductors, only. Do not use aluminum wire.
- If multiple heat pumps are on-site, confirm that a multiple heat pump configuration has been utilized. This will prevent multiple heat pumps from attempting to start at the same time, causing an excessive power drop at start-up. This can be done with either an external sequencing controller, or if equipped, a heat pump option.
- If a fixed device does not have a power cord and plug, or any other means to disconnect from the power supply with separation of the contacts in all poles, enabling total disconnection in case of a category III electrical surge, the manual will specify that the disconnection means must be integrated into the fixed wiring, as per relevant wiring rules.
- An appropriate disconnection method, complying with all local and national requirements relating to category III electrical surges, and that disconnects all poles of the supply circuit, must be installed in the device's supply circuit. This disconnection method is not provided with the device and should be supplied by the installation technician.
- Prior to installation, ensure that:
 - The voltage indicated on the device's information plate matches the voltage of the power supply.
 - The power supply is suitable for operating the device and has a ground connection.
 - Any electrical plug (if necessary) is designed to properly fit the electrical outlet.
- Do not use an extension cord to connect the device; connect the device directly to a suitable power outlet.
- If a power cord is used and it becomes damaged, it must be replaced by a qualified individual.

NOTICE

Failure to heed the following may result in damage to equipment.

- Maintain proper water chemistry to avoid damage to the pump, filter, pool shell, etc.
- Water flow exceeding the maximum flow rate requires a bypass. Damage due to excessive water flow will void the warranty.
- Failure to protect equipment against corrosive conditions will adversely affect the life of the equipment and will void equipment warranty.
- The device is designed specifically for use in swimming pools and spas; it must not be used for purposes other than designed.

SAVE THESE INSTRUCTIONS

1 - Flammable Refrigerant



Refrigerant Safety
Group A2L

Failure to heed the following may result in injury or death.

- This equipment contains a refrigerant of category A2L. This refrigerant is a greenhouse effect fluorinated gas, covered by the Kyoto Protocol, with a global warming potential. This refrigerant is considered as potentially flammable. Procedures in this section outline proper handling of equipment and refrigerant.

Checks to the area

Prior to beginning work on systems containing FLAMMABLE REFRIGERANTS, safety checks are necessary to ensure that the risk of ignition is minimized.

Work procedure

Work shall be undertaken, under a controlled procedure, so as to minimize the risk of a flammable gas or vapor being present while the work is being performed.

General Work Area

All maintenance staff and others working in the local area shall be instructed on the nature of work being carried out. Work in confined spaces shall be avoided.

Checking for the presence of refrigerant

The area shall be checked with an appropriate refrigerant detector prior to and during work to ensure the technician is aware of potentially toxic or flammable atmospheres. Ensure that the leak detection equipment being used is suitable for use with all applicable refrigerants, i.e. non-sparking, adequately sealed or intrinsically safe.

Presence of a fire extinguisher

If any hot work is to be conducted on the refrigerating equipment or any associated parts, appropriate fire extinguishing equipment shall be available to hand. Have a dry power or CO fire extinguished adjacent to the charging area.

No ignition sources

No person carrying out work in relation to a REFRIGERATING SYSTEM which involves exposing any pipe work shall use any sources of ignition in such a manner that it may lead to the risk of fire or explosion. Possible ignition sources, including cigarette smoking, should be kept sufficiently far away from the site of installation, repairing, removing and disposal, during which refrigerant can possibly be released to the surrounding space. Prior to work taking place, the area around the equipment is to be surveyed to make sure that there are no flammable hazards or ignition risks. "No Smoking" signs shall be displayed.

If winterizing equipment

- DO NOT use a means to accelerate the defrosting process, other than those recommended by the manufacturer.
- If the equipment is to be removed and stored, confirm possible ignition sources, such as gas heaters with a pilot light, cigarette smoking, etc. are kept sufficiently far away from the equipment.
- The area around the equipment is to be surveyed to make sure that there are no flammable hazards or ignition risks.
- "No Smoking" signs shall be displayed in the area.

Ventilated area

Ensure that the area is in the open or that it is adequately ventilated before breaking into the system or conducting any hot work. An adequate degree of ventilation shall continue during the period that the work is carried out. The ventilation should safely disperse any released refrigerant and preferably expel it externally into the atmosphere.

Checks to the refrigeration equipment

Where electrical components are being changed, they shall be fit for the purpose and to the correct specification. At all times the manufacturer's maintenance and service guidelines shall be followed. If in doubt, consult the manufacturer's technical department for assistance.

The following checks shall be applied to installations using FLAMMABLE REFRIGERANTS.

- The actual REFRIGERANT CHARGE is in accordance with the room size, within which the refrigerant containing parts are installed. This equipment is NOT intended to be installed indoors.
- The ventilation machinery and outlets are operating adequately and are not obstructed.
- If an indirect refrigerating circuit is being used, the secondary circuit shall be checked for the presence of refrigerant.
- Marking to the equipment continues to be visible and legible. Marking and signs that are illegible shall be corrected.
- Refrigerating pipe or components are installed in a position where they are unlikely to be exposed to any substance which may corrode refrigerant containing components, unless the components are constructed of materials which are inherently resistant to being corroded or are suitable protected against being so corroded.

Checks to electrical devices

Repair and maintenance to electrical components shall include initial safety checks and component inspections procedures. If a fault exists that could compromise safety, then no electrical supply shall be connected to the circuit until it is satisfactorily dealt with. If the fault cannot be corrected immediately, but it is necessary to continue operation, an adequate temporary solution shall be used. This shall be reported to the owner of the equipment so all parties are advised.

Initial safety checks shall include:

- That capacitors are discharged; this shall be done in a safe manner to avoid the possibility of sparking.
- That no live electrical components or wiring are exposed while charging, recovering, or purging the system.
- That there is continuity of earth (ground) bonding.

Detection of flammable refrigerants

Under no circumstances shall potential sources of ignition be used in the searching for or detection of refrigerant leaks; such as a halide torch (or any other detector using a naked flame).

The following leak detection methods are deemed acceptable for all refrigerant systems.

- Electronic leak detectors may be used to detect refrigerant leaks, but in the case of FLAMMABLE REFRIGERANTS, the sensitivity may not be adequate, or may need re-calibration. (Detection equipment shall be calibrated in a refrigerant-free area). Ensure that the detector is not a potential source of ignition and is suitable for the refrigerant used. Leak detection equipment shall be set at a percentage of the LFL of the refrigerant and shall be calibrated to the refrigerant employed, and the appropriate percentage of gas (25 % maximum) is confirmed.
- PLEASE NOTE - Leak detectors may be used provided they are certified by the manufacturer for use with this specific refrigerant and comply with current standards for safety and flammability.
- Leak detection fluids are also suitable for use with most refrigerants but the use of detergents containing chlorine shall be avoided as the chlorine may react with the refrigerant and corrode the copper pipe-work.

NOTE: EXAMPLES OF LEAK DETECTION FLUIDS ARE:

- Bubble method
 - Fluorescent method agents
- If a leak is suspected, all naked flames shall be removed / extinguished.
 - If a refrigerant leak is found which requires brazing, all of the refrigerant shall be recovered from the system, or isolated (by means of shut off valves) in a part of the system remote from the leak. Removal of refrigerant shall be according to the below guidance.

Removal and Evacuation

When breaking into the refrigerant circuit to make repairs - or for any other purpose - conventional procedures shall be used. However, for flammable refrigerants, it is important that best practice be followed since flammability is a consideration. The following procedure shall be adhered to:

- Safely remove refrigerant following local and national regulations;
- Evacuate the system;
- Purge the circuit with inert gas;
- Evacuate the system;
- Continuously flush or purge with inert gas when using flame to open the circuit; and
- Open the circuit.

The refrigerant charge shall be recovered into the correct recovery cylinders if venting is not allowed by local and national codes. For appliances containing flammable refrigerants, the system shall be purged with oxygen-free nitrogen to render the appliance safe for flammable refrigerants. This process might need to be repeated several times. Compressed air or oxygen shall not be used for purging refrigerant systems.

- After refrigerant recovery of appliances containing flammable refrigerants, refrigerant purging shall be achieved by breaking the vacuum in the system with oxygen-free nitrogen and continuing to fill until the working pressure is achieved, then venting to atmosphere, and finally pulling down to a vacuum. This process shall be repeated until no refrigerant is within the system. When the final oxygen-free nitrogen charge is used, the system shall be vented down to atmospheric pressure to enable work to take place.

The outlet for the vacuum pump shall not be close to any potential ignition sources, and ventilation shall be available.

Do not use a means to accelerate the defrosting process or to clean the equipment, other than those recommended by the manufacturer.

Repairs to intrinsically safe components

- Sealed electrical components shall be replaced.
- Intrinsically safe components must be replaced.
- Components must meet OEM specifications, certifications, performance, fit and / or compatibility.

Charging procedures:

In addition to conventional charging procedures, the following requirements shall be followed.

- These procedures must be performed by a qualified HVAC technician.
- Ensure that contamination of different refrigerants does not occur when using charging equipment. Hoses or lines shall be as short as possible to minimize the amount of refrigerant contained in them.
- Cylinders shall be kept in an appropriate position according to the instructions.
- Ensure that the REFRIGERATING SYSTEM is earthed (grounded) prior to charging the system with refrigerant.
- Label the system when charging is complete (if not already).
- Extreme care shall be taken not to overfill the REFRIGERATING SYSTEM.

Prior to recharging the system, it shall be pressure-tested with the appropriate purging gas. The system shall be leak-tested on completion of charging but prior to commissioning. A follow up leak test shall be carried out prior to leaving the site.

Decommissioning:



Before carrying out this procedure, it is essential that the technician is completely familiar with the equipment and all its detail. It is recommended good practice that all refrigerants are recovered safely. Prior to the task being carried out, an oil and refrigerant sample shall be taken in case analysis is required prior to re-use of recovered refrigerant. It is essential that electrical power is available before the task is commenced.

- a. Become familiar with the equipment and its operation.
- b. Isolate system electrically.
- c. Before attempting the procedure, ensure that:
 - mechanical handling equipment is available, if required, for handling refrigerant cylinders;
 - all personal protective equipment is available and being used correctly;
 - the recovery process is supervised at all times by a competent person;
 - recovery equipment and cylinders conform to the appropriate standards.
- d. Pump down refrigerant system, if possible.
- e. If a vacuum is not possible, make a manifold so that refrigerant can be removed from various parts of the system.
- f. Make sure that cylinder is situated on the scales before recovery takes place.
- g. Start the recovery machine and operate in accordance with instructions.
- h. Do not overfill cylinders (no more than 80% volume liquid charge).
- i. Do not exceed the maximum working pressure of the cylinder, even temporarily.
- j. When the cylinders have been filled correctly and the process completed, make sure that the cylinders and the equipment are removed from site promptly and all isolation valves on the equipment are closed off.
- k. Recovered refrigerant shall not be charged into another REFRIGERATION SYSTEM unless it has been cleaned and checked.

Labeling

Equipment shall be labeled stating that it has been decommissioned and emptied of refrigerant. The label shall be dated and signed. For appliances containing FLAMMABLE REFRIGERANTS, ensure that there are labels on the equipment stating the equipment contains FLAMMABLE REFRIGERANT.

Recovery

When removing refrigerant from a system, either for servicing or decommissioning, it is a recommended good practice that all refrigerants are removed safely.

When transferring refrigerant into cylinders, ensure that only appropriate refrigerant recovery cylinders are employed. Ensure that the correct number of cylinders for holding the total system charge is available. All cylinders to be used are designated for the recovered refrigerant and labeled for that refrigerant (i.e. special cylinders for the recovery of refrigerant). Cylinders shall be complete with pressure-relief valve and associated shut-off valve in good working order. Empty recovery cylinders are evacuated and, if possible, cooled before recovery occurs.

The recovery equipment shall be in good working order with a set of instructions concerning the equipment that is at hand and shall be suitable for the recovery of the flammable refrigerant. If in doubt, the manufacturer should be consulted. In addition, a set of calibrated weighing scales shall be available and in good working order. Hoses shall be complete with leak-free disconnect couplings and in good condition.

The recovery refrigerant shall be processed according to local legislation in the correct recovery cylinder, and the relevant waste transfer note arranged. Do not mix refrigerants in the recovery units and especially not in cylinders.

If compressors or compressor oils are to be removed, ensure that they have been evacuated to an acceptable level to make certain that flammable refrigerant does not remain within the lubricant. The compressor body shall not be heated by an open flame or other ignition sources to accelerate this process. When oil is drained from system, it shall be carried out safely.

SAVE THESE INSTRUCTIONS

2 - Installation

DANGER

Failure to heed the following will result in injury or death.

- Deactivate power while routing wiring to control board.
- Heat Pump equipment must be installed within manufacturer specifications and must follow all National and/or State and Local installation guidelines.
- Follow all National Electric Codes (NEC) and/or State and Local guidelines.

WARNING

Failure to heed the following may result in injury or death.

- Installation of this equipment by anyone other than a qualified installer can result in a safety hazard.
- The information contained throughout the "Installation" section is intended for use by qualified installation technicians familiar with the swimming Pool/Spa safety standards.

NOTICE

Failure to heed the following may result in damage to equipment.

- Failure to protect equipment against corrosive conditions will adversely affect the life of the equipment and will void equipment warranty.
- Do not install equipment inside of a building.

IN THIS SECTION:

2.1 Transporting Equipment	13
2.2 Positioning Equipment	14
2.3 Plumbing	17
2.4 Electrical	20
2.5 Installer Start Up Check List	26

2.1 Transporting Equipment

- The heat pump should always be stored and transported in a vertical position, on a pallet, and inside its original packaging. Transporting and / or storing the heat pump horizontally will void the product warranty.
- When the equipment is unpacked, check the contents and report any damage or missing items.
- Check that the pressure reading on the pressure gauge corresponds to the outside temperature, as different values might indicate a leak.

2.2 Positioning Equipment

Outdoor Use Only



WARNING

Failure to heed the following may result in injury or death.

- DO NOT INSTALL EQUIPMENT INSIDE OF A BUILDING
- This heat pump contains A2L type refrigerant and is not rated to be installed indoors or in an equipment room.
- Heat Pumps also require unobstructed airflow for proper operation.

Clearances

- Proper air circulation is required for the heat pump to operate efficiently. View the diagram showing minimum clearances required for the proper operation of the heat pump.
- Avoid storing corrosive chemicals near the heat pump to minimize potential damage to the exterior of the heat pump.
- Avoid placing objects near or on top of the heat pump. This includes shrubbery and lawn furniture. These objects will reduce performance and efficiency and hinder maintenance access.
- **Heat pumps must not be installed indoors or in enclosed areas.**

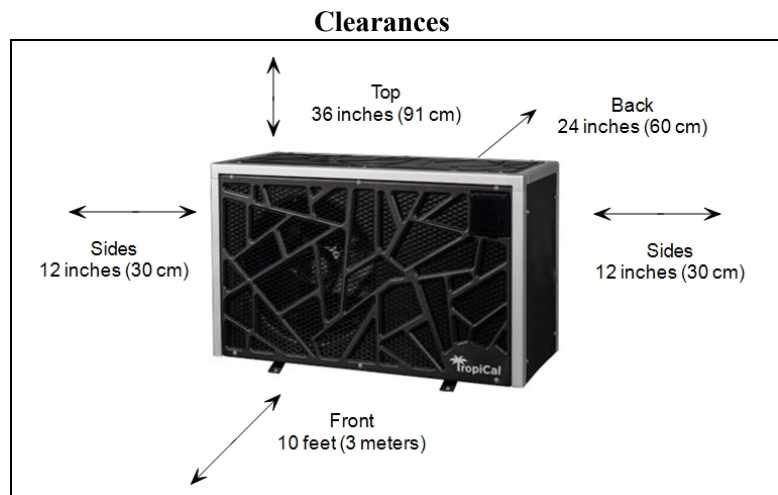

Controlling Irrigation and Rainwater Runoff

- Irrigation water may damage heat pump components. Direct irrigation water away from the heat pump.
- The heat pump will withstand normal rainfall. Do not allow a roof slope to direct rainwater onto the heat pump. Have a gutter installed on the roof edge to direct this water away from the heat pump. Or install the heat pump in another location.

Planning for Condensation

The heat pump can produce a large amount of condensation. The amount of water depends on air temperature and humidity.

- Install the heat pump with enough height to allow for water drainage.
- A condensation hose has been provided to connect to the drainage outlet located on the bottom of the heat pump.

Mounting Pad Requirements

Install the equipment as follows:

- The heat pump's base must be installed on a flat and level surface that completely supports the entire base.
- Build the heat pump pad out of concrete or other code-approved material. This pad must be separate from the building foundation.
- Confirm the pad can support the weight of the heat pump.
- Elevate the pad enough to allow for drainage.
- Make sure the pad is flat and level.
- Have the pad support the entire heat pump base in all directions.
- Vibration dampers have been supplied to use between the heat pump base and floor.
- Install it in an open area where possible (sound waves bounce off surfaces).
- Equipment pad must meet all requirements of authorities having code-related jurisdiction.
- Heat Pump equipment must be installed within manufacturer specifications and must follow all National and/or State and Local installation guidelines.

Avoid installing as follows:

- In an area covered by sprinkling systems, or subject to spray or running water or mud. Such as close to a road, or in an area of high wind, which can divert sprinkling system water into the equipment.
- Under a tree where debris can fall into the equipment area and block ventilation.
- Close to a source of heat or flammable gas. See "*Flammable Refrigerant* " on page 7.
- In an area where the equipment can be exposed to oil, flammable gases, corrosive products, or compounds containing sulfur.
- Close to equipment operating at high frequencies. See "*FCC Compliance*" on page 49.
- In a place where snow is likely to accumulate.
- In a place where it could be flooded by the condensates produced by the device as it operates.
- Do not install the heat pump on soil or grass.
- Do not direct the fan outlet (cold air) towards the swimming pool.
- Do not place the heat pump directly on a concrete floor. This can cause noise to be transmitted to an occupied space.
- Do not allow the heat pump base to touch the building's foundation.
- Do not install it close to or underneath a window.

Anchoring to Pad

- Follow all applicable local, state, and national requirements regarding wind load anchoring.

Anchor points (on base of unit)

Model	A	B	C
T70	27 9/16 in (700 mm)	18 1/2 in (470 mm)	16 17/32 in (420 mm)
T100	29 5/8 in (753 mm)	20 15/32 in (520 mm)	18 1/2 in (470 mm)
T130	27 in (685 mm)	20 1/16 in (510 mm)	18 5/16 in (465 mm)

T70

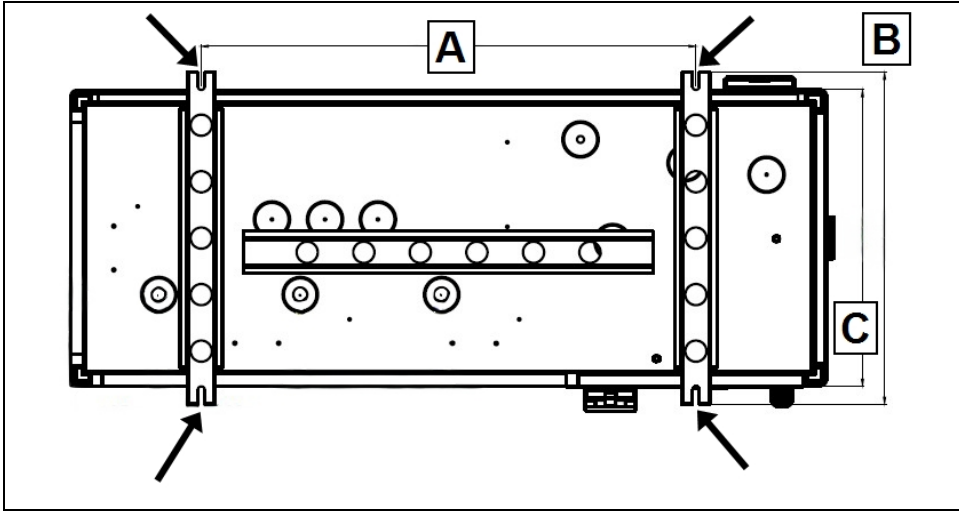

T100

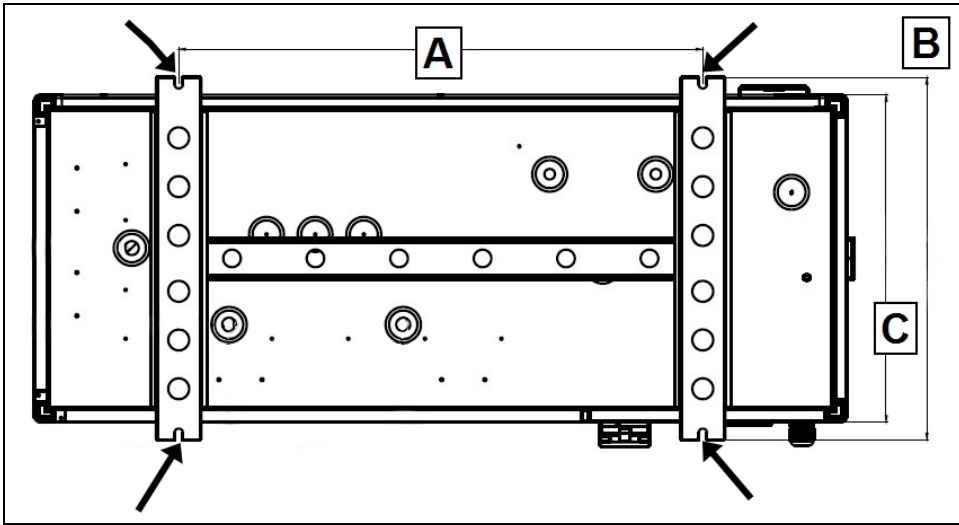

T130

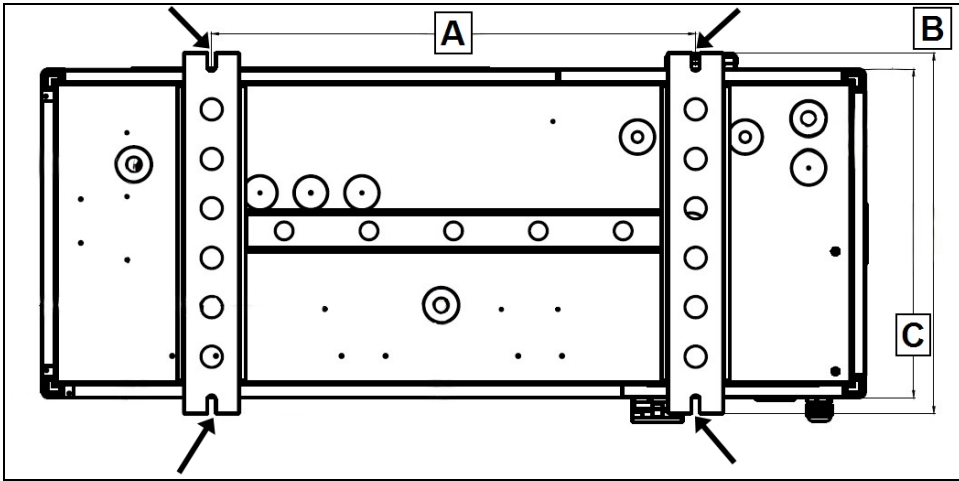

2.3 Plumbing

2.3.A Plumbing Requirements

- The Heat pump must be connected to the swimming pool's hydraulic circuit using 2 inch PVC pipe, after the filter system and before the treatment system, regardless of its type (Cl, pH, Br metering pumps and / or electrolysis systems).
 - The Heat pump is compatible with all types of water treatment.
- A bypass valve system as shown (or a bypass check valve) must be installed to facilitate work on the Heat pump.
- Before connecting the PVC pipes to the Heat pump, make sure the circuit is clean of any work residue (stone, soil, etc.).
- The heat pump must receive water flow under worst-case conditions such as a fouled water filter.
- Water flow exceeding maximum flow rates will negatively affect the total pool filtration performance and may damage the heat pump. This will not be covered under the equipment warranty.
- Follow the basic plumbing diagrams as shown. See 2.3.A.
- For ideal water balance and heat pump efficiency, it is recommended that three valves be installed before the heat pump; Two isolation valves, and one adjustment valve as indicated.

Follow the hydraulic connection order (blue = water in, red = water out)

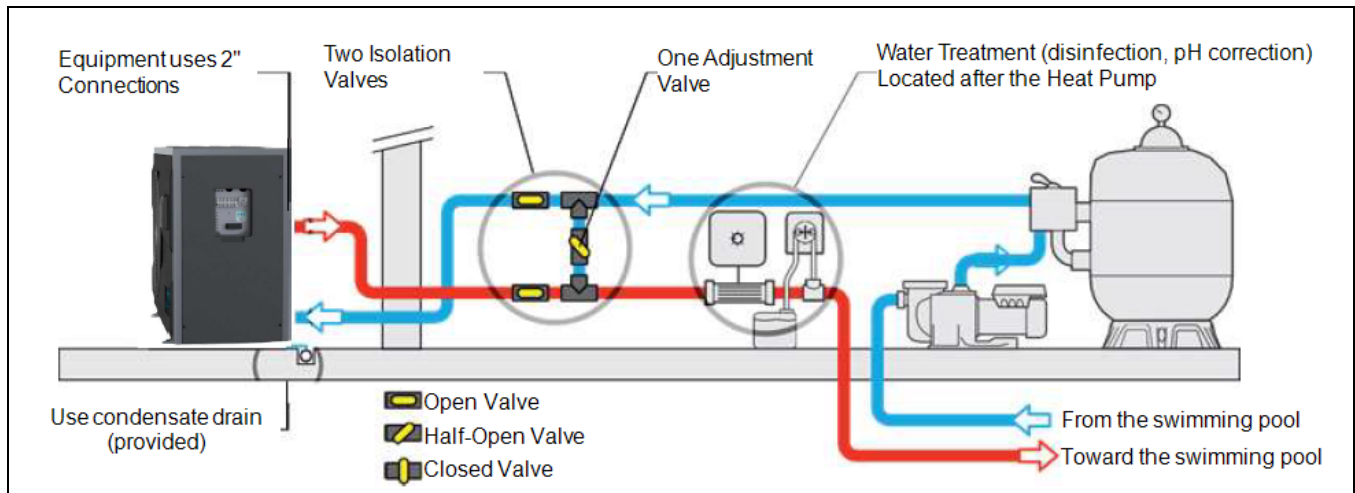

Figure 1

2.3.B Maintaining Ability to Winterize

NOTICE

Failure to heed the following may result in damage to equipment.

- Do not use glue on the threaded portion of the equipment's unions. A glued-in-place union will prevent the equipment from being properly winterized.

2.3.C Water Connections to Heat Pump

- Heat Pump union sizes are specified on diagram(s).
- Connections to site plumbing are made via PVC solvent cement to the female slip socket of the plumbing unions.
- Plumbing unions are available from AquaCal®.

TropiCal® T70

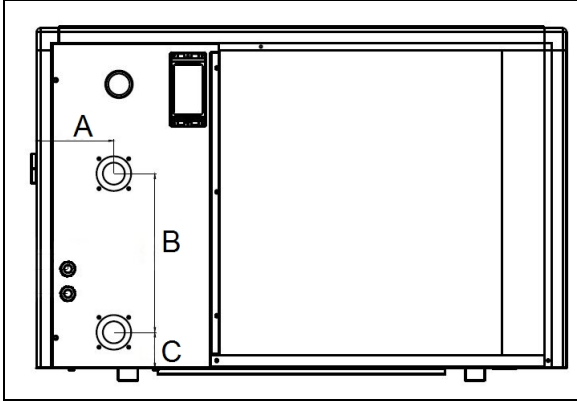

Label	Dimension
Union Size	2 Inches (50 mm)
A	6 1/8 inches (156 mm)
B	12 5/8 inches (320 mm)
C	2 3/4 inches (72 mm)

TropiCal® T100

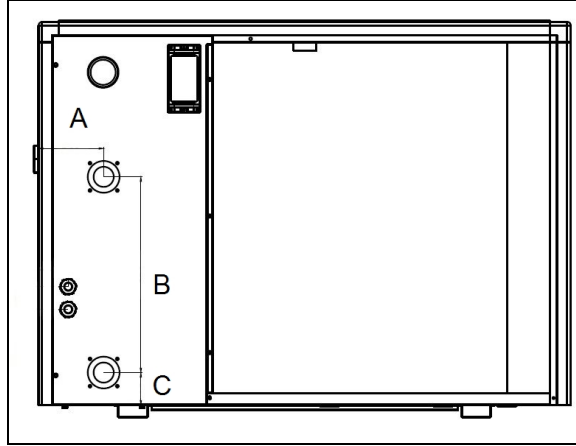

Label	Dimension
Union Size	2 Inches (50 mm)
A	6 1/8 inches (156 mm)
B	12 5/8 inches (320 mm)
C	2 3/4 inches (72 mm)

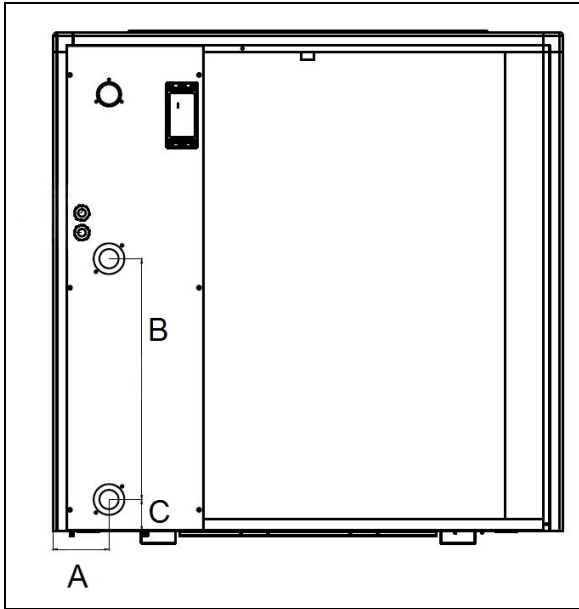

Label	Dimension
Union Size	2 Inches (50 mm)
A	6 1/8 inches (156 mm)
B	12 5/8 inches (320 mm)
C	2 3/4 inches (72 mm)

2.3.D In-Line Chlorine Feeders

Place in-line chlorinators downstream from the heat pump and as low in elevation as possible.

- If an erosion type feeder is used, it is recommended that a Hartford Loop be installed to protect internal heat pump components.
- A Hartford Loop is not required when using a Salt Chlorine Generator.
- Avoid storing corrosive chemicals near the heat pump to minimize potential damage to the exterior of the heat pump.
- Heat Pump equipment shall not be installed immediately after an injection point of low pH or acidic chemicals. This will minimize potential corrosive damage to the inside of the heater.

Heat Pump with Erosion Tablet Feeder and Hartford Loop

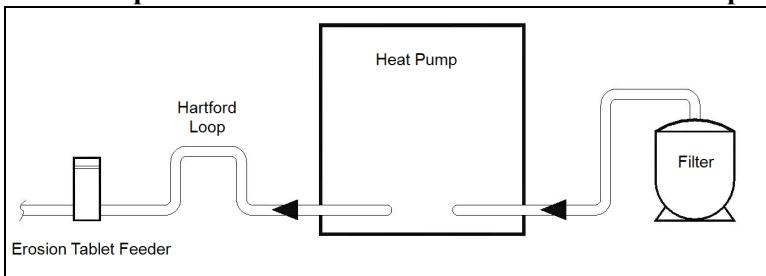

2.3.E Water Flow Rates

Maintain water flow rates as indicated. Please note, these specifications relate to the heat pump only. Code-specified whole system turnover rates must be satisfied.

NOTICE

Failure to heed the following may result in damage to equipment.

- Water flow exceeding maximum flow rates will negatively affect the total pool filtration performance and may damage the heat pump. This will not be covered under the equipment warranty.

MODEL	FLOW RATES	
	MINIMUM	MAXIMUM
T70	20 GPM (90.9 L/min)	60 GPM (272.8 L/min)
T100	30 GPM (136.4 L/min)	70 GPM (318.2 L/min)
T130	30 GPM (136.4 L/min)	70 GPM (318.2 L/min)

- Water flow exceeding maximum flow rates will negatively affect the total pool filtration performance and may damage the heat pump. This will not be covered under the equipment warranty.
- Additional installation advice is available online. See "*Contacting AquaCal AutoPilot, Inc.*".
- Operate water filtration devices per manufacturer's specifications. Dirty filters can cause a reduction of water flow to the heat pump. An increase of 7-10 psi (48 to 69 kPa) higher than the clean filter pressure typically reduces flow rates. This requires the filter to be cleaned or back-washed.
- Keep baskets free of debris. A large quantity of debris in the pump and skimmer baskets can reduce water flow.

2.4 Electrical

2.4.A Electrical Requirements

Grounding and Bonding

Follow local code requirements for proper grounding and bonding of heat pump equipment.

Surge Suppression

The use of approved commercial surge protectors is strongly recommended.

Sizing the Electrical Service

Refer to equipment data plate for specific information required to size electrical service and over-current protection of the heat pump. Sizing is based on data plate information, wire size, wiring devices, and over-current protection per applicable local codes and standards.

- Refer to equipment data plate for specifications on breaker sizing.
- If allowed by local codes, a device with a 20mA rating is strongly recommended to help reduce or eliminate nuisance tripping.

PLEASE NOTE:

- *GFCI devices with a 5mA trip rating are known to experience nuisance trips when connected to HVAC equipment.*
- *Nuisance tripping does not indicate a problem with the unit and is not covered by the factory warranty.*

Minimum and Maximum Operating Voltage

The heat pump must operate within specified voltages.

NOTICE

Failure to heed the following may result in damage to equipment.

- Operating equipment under higher or lower voltage conditions may result in damage to your compressor, motors or other electrical components. This damage will not be covered by the product warranty.
- If measured site voltage is outside listed ranges, immediately deactivate equipment until site conditions have been corrected.

Verifying Site Voltage

Confirm site voltage supplied to heat pump matches the data plate on the equipment. Incorrect applied voltage will cause heat pump damage.

Additional installation advice is available online. See "*Contacting AquaCal AutoPilot, Inc.*".

Equipment Rating	Minimum Site Voltage	Maximum Site Voltage
Single Phase 60 hertz and Single Phase 50 hertz	200 Volts	253 Volts

2.4.B Schematics

PLEASE NOTE:

- A schematic is located inside the top access plate on the unit.
- Specifications are subject to change without notice.
- Schematics are also available by calling AquaCal® Customer Support. See "*Contacting AquaCal AutoPilot, Inc.*"
 - Please have the complete model and serial number available.

2.4.C Access Panels

DANGER

Failure to heed the following will result in injury or death.

- Deactivate power while routing wiring to control board.
- Heat Pump equipment must be installed within manufacturer specifications and must follow all National and/or State and Local installation guidelines.
- Follow all National Electric Codes (NEC) and/or State and Local guidelines.

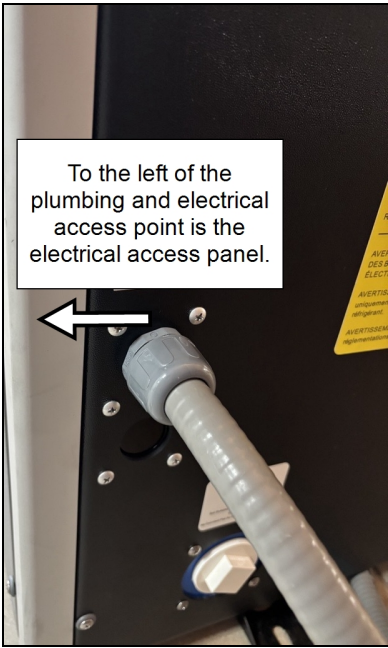

TropiCal®

2.4.D Incoming Power Access Holes

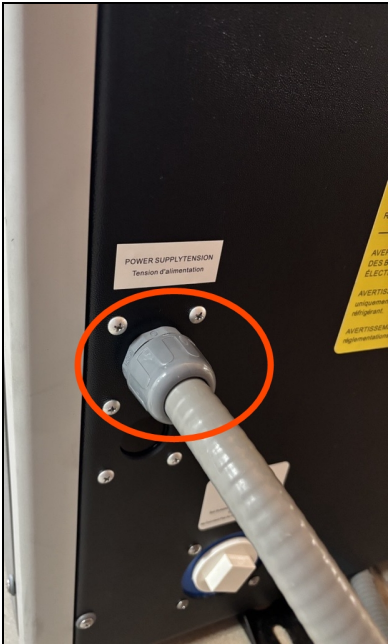

TropiCal®

2.4.E Connection Points

Line Voltage's Connection Point

Connect wires to L(L1), N(L2), and Ground as indicated (Neutral is not required). Follow all National Electric Codes (NEC) and / or State and Local guidelines.

It is strongly recommended that wire terminals are used for a secure electrical contact between the wire and power supply terminals. See Figure 2 and Figure 3.

T70

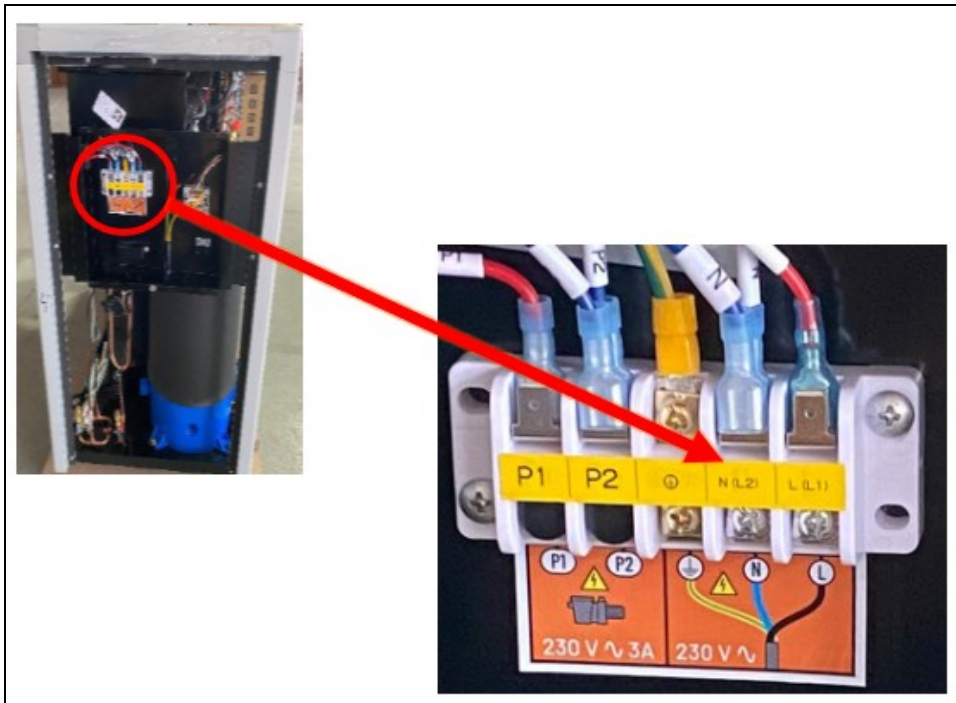

Wire
Terminals



Figure 2

T100 and T130

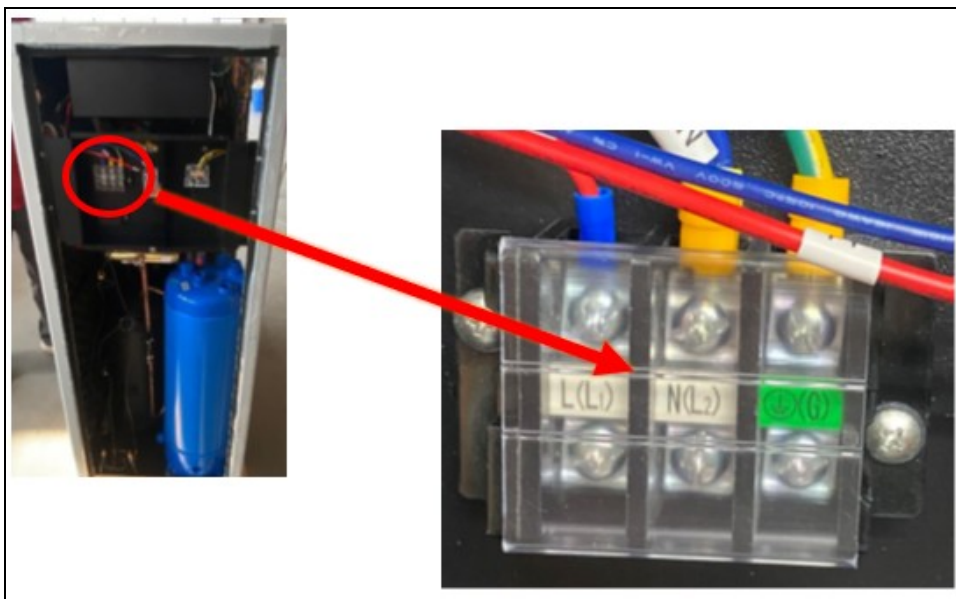

Figure 3

2.4.F Circulation Pump's Connection Point

The water circulation pump can be connected to the heat pump to force pump operation if the water is not at the desired water temperature.

1. A suitable relay with a 230 V coil must be provided by the installer.
2. Connect the coil of the relay ("A1" and "A2") to the "P1" and "P2" terminals to the heat pump as indicated. See Figure 4, Figure 5, and Figure 6.
3. Connect the pump wiring to the relay in parallel with the filtration time clock.
4. Program the heat pump to control the circulation pump. See "*Programming for Circulation Pump Extend Mode*" on page 37.

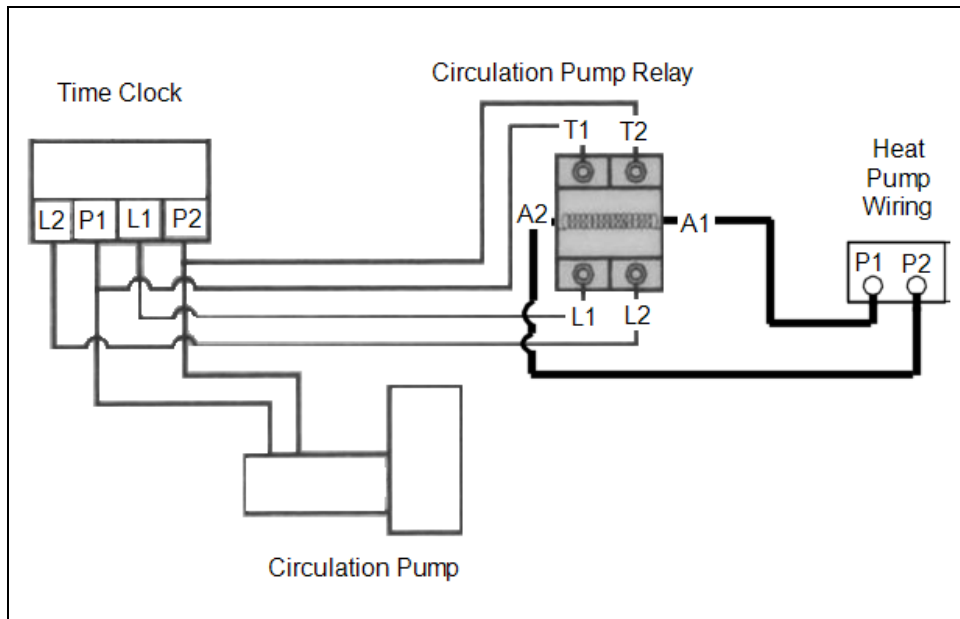

Figure 4

T70 (P1 and P2)

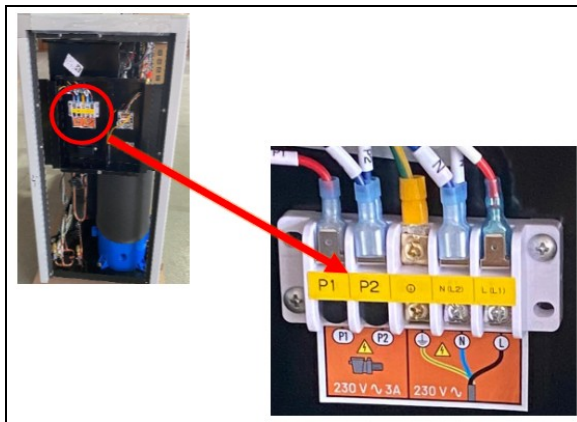

Figure 5

T100 and T130 (P1 and P2)

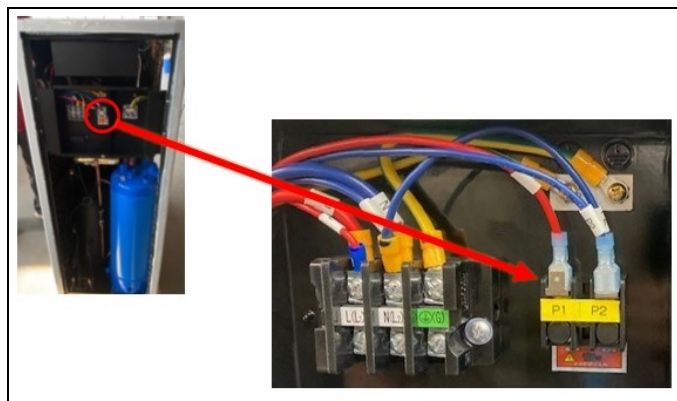

Figure 6

2.4.G Connecting an External (2-wire Dry Contact) Controller

A low voltage terminal block (dry contact) is available to connect to an external controller if needed.

1. Remove the jumper from the On / Off terminals.
2. Connect the external controller dry contact wires to the On / Off terminals.
 - **Be sure to press the orange blocks to release when removing and connecting wires.**
 - **Do not connect the RS485 external controller wires (this unit does not have RS485 communication abilities).**
3. Set the system to Boost Mode and the maximum temperature at the heat pump.
 - Seeing a lower temperature at the heat pump will limit operation to that temperature.

2-wire Controller

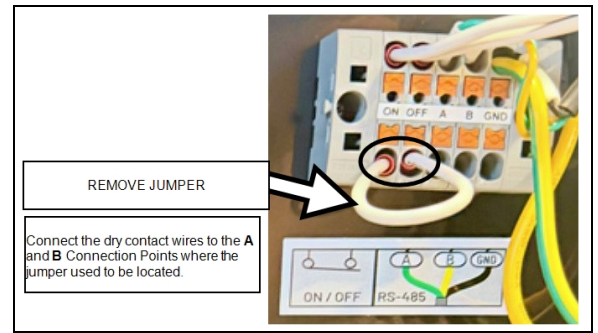

Figure 7

Alternate method for small gauge wire.

1. Cut the jumper wire in the middle, do not disconnect.
2. Attached the 2 wires from the dry contacts, one to each of the cut jumper wires.

The system will indicate no flow (even when flow is present) when the controller is not actively calling for heating.

Do not use A and B connection blocks

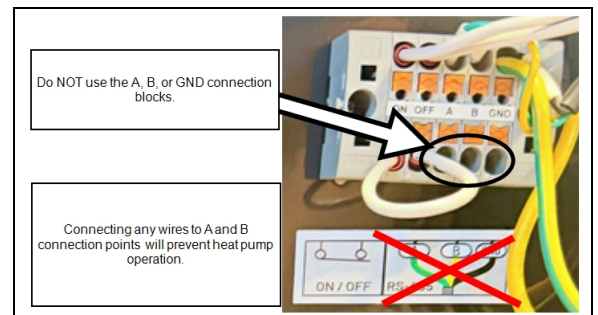

Figure 8

2.5 Installer Start Up Check List

Once the heat pump is connected to the water circuit with the bypass, and is connected to the power supply by a technician, perform the following:

- Confirm the heat pump is level on the pad.
- Confirm the heat pump is secured and stable.
- Have the water circuit purged of air trapped in the piping of the heat pump.
- Confirm the water circuit is properly connected with no leaks or damage. And confirm that the connections are properly tightened (hand tight).
- Confirm the electric circuit is properly connected and connected to the ground connection.
- Confirm the outdoor temperature is between 5° F (-15° C) and 109° F (+43° C).
- Confirm the water temperature is a minimum of 59° F (15° C).
- Confirm the evaporator at the rear and sides of the heat pump is clean (leaves, dust, pollen, cobwebs, etc.).
- Check the pressure gauge on the back of the unit. Confirm that the unit is in the green range on the gauge. Write down the pressure when system is off. This information will be used later.

The heat pump can now be started by following these steps in sequence.:

- Remove all unused items or tools from the area surrounding the heat pump.
- Open the bypass valves (refer to the hydraulic diagram provided). See "*Plumbing Requirements*" on page 17.
- Half-close the bypass marked adjustment valve on the plumbing diagram on plumbing requirements.
- Activate the heat pump by engaging the circuit-breaker and using the ON / OFF button on the display.
- The heat pump should start after a delay of a few minutes.
- Check that the heat pump starts and stops in sync with the filtration circuit; if no water is detected in the heat pump, the display should show "FLO".
- Adjust the temperature. See "*Control Panel*" on the facing page.
- Adjust the water flow. See "*Water Flow Adjustment Procedure*" on page 46.
 - Wait for 5 minutes for system to equalize. The pressure gauge should increase by 9.1 bar from starting pressure.
 - If the system is over or under 9.1 bar, continue to adjust valve, wait for 5 minutes, and monitor until the system is at the ideal pressure (within the starting range plus (+) 9.1 bar). This range should allow the heat pump to operate as efficiently as possible.
- Having completed the above steps, use a pool cover if available and let the heat pump operate for a few days with the filtration pump active until the water reaches the desired water temperature.

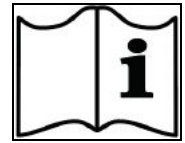

3 - Operation

IN THIS SECTION:

3.1 Control Panel	27
3.2 Programming	28
3.2.A Activating / Deactivating the Heat Pump	29
3.2.B Setting a desired water temperature setpoint	29
3.2.C Selecting Celsius or Fahrenheit	30
3.2.D Activate HEAT Mode, COOL Mode, or AUTO Mode	30
3.2.E Set Efficiency Mode	32
3.2.F Setting Heat Pump Time of Day	33
3.2.G Entry Lock Option	34
3.3 Optional Programming	36
3.3.A The TropiCal® Heat Pump using WiFi	36
3.3.B Programming for Circulation Pump Extend Mode	37

3.1 Control Panel

Main Panel

See Programming on page 28. for more information.

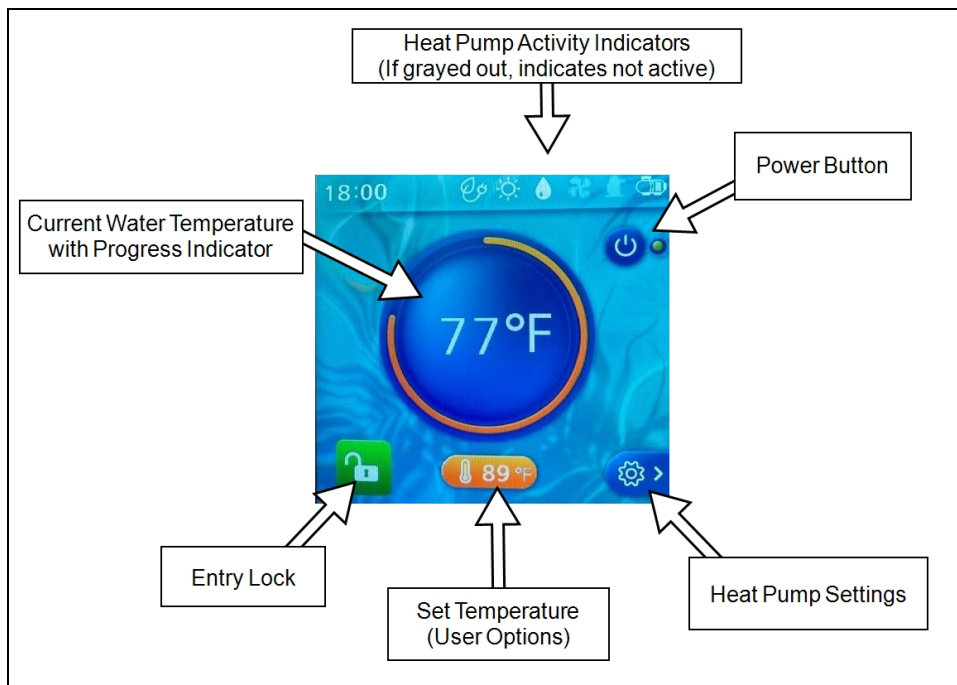

Example of Indicators at Top of Main Screen

NOTE

If indicator is grayed out, the item is not active.

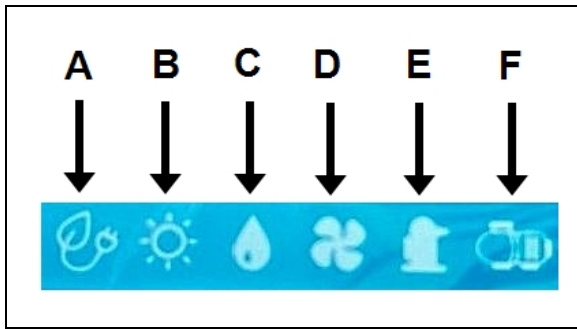

LABEL	DESCRIPTION
A	Efficiency Mode set to Eco-Silent. (See page 32 for more information)
B	Heat, Cool, Auto Mode is set to Heat. (See page 30 for more information)
C	Indicates heat pump is Receiving Water
D	Indicates Fan is Operating
E	Indicates Compressor is Operating
F	Indicates a Connected Circulation Pump is Operating

Error Codes

Error codes will display on the face of the display. Codes in Blue are low priority. Codes in Red are urgent and require attention. See Troubleshooting on page 55. for more information.



3.2 Programming

IN THIS SECTION:

3.2.A Activating / Deactivating the Heat Pump	29
3.2.B Setting a desired water temperature setpoint	29
3.2.C Selecting Celsius or Fahrenheit	30
3.2.D Activate HEAT Mode, COOL Mode, or AUTO Mode	30
3.2.E Set Efficiency Mode	32
3.2.F Setting Heat Pump Time of Day	33
3.2.G Entry Lock Option	34

3.2.A Activating / Deactivating the Heat Pump



3.2.B Setting a desired water temperature setpoint

Set a desired water temperature (setpoint) for the Heat Pump to activate.

- The maximum temperature the Heat Pump can be set to is 104° F (40° C).
- The heat pump will not operate if incoming water temperatures are above 108° F (42° C). If sustained water temperatures will fall below 32° F (0° C), the equipment must be winterized in order to prevent damage. See "Winterizing" on page 50.

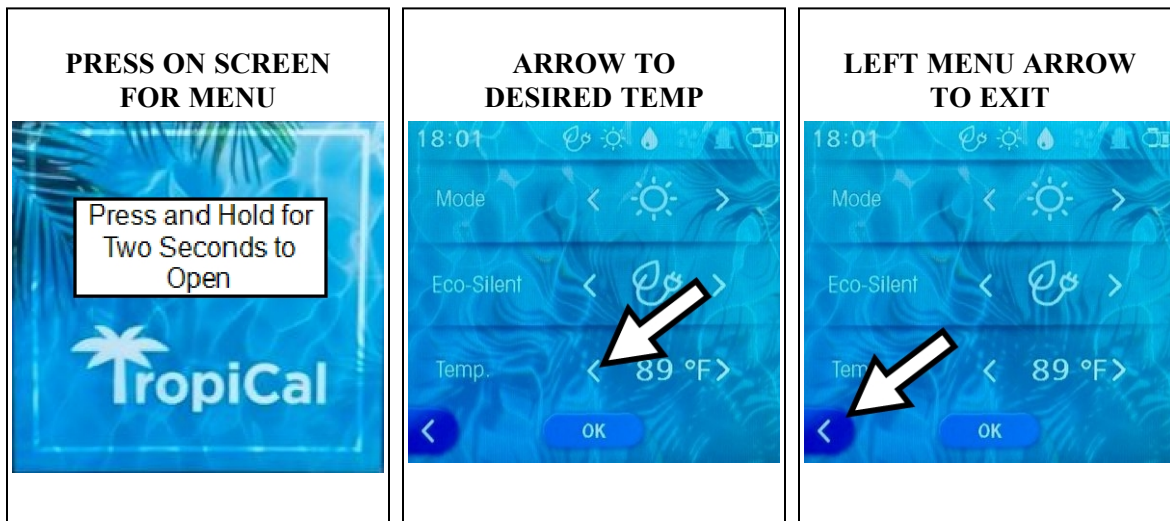

3.2.C Selecting Celsius or Fahrenheit

The user has the option of changing the way the water temperature is displayed. Either in Fahrenheit or Celsius. In the following example, the temperature units are changed from Fahrenheit to Celsius.

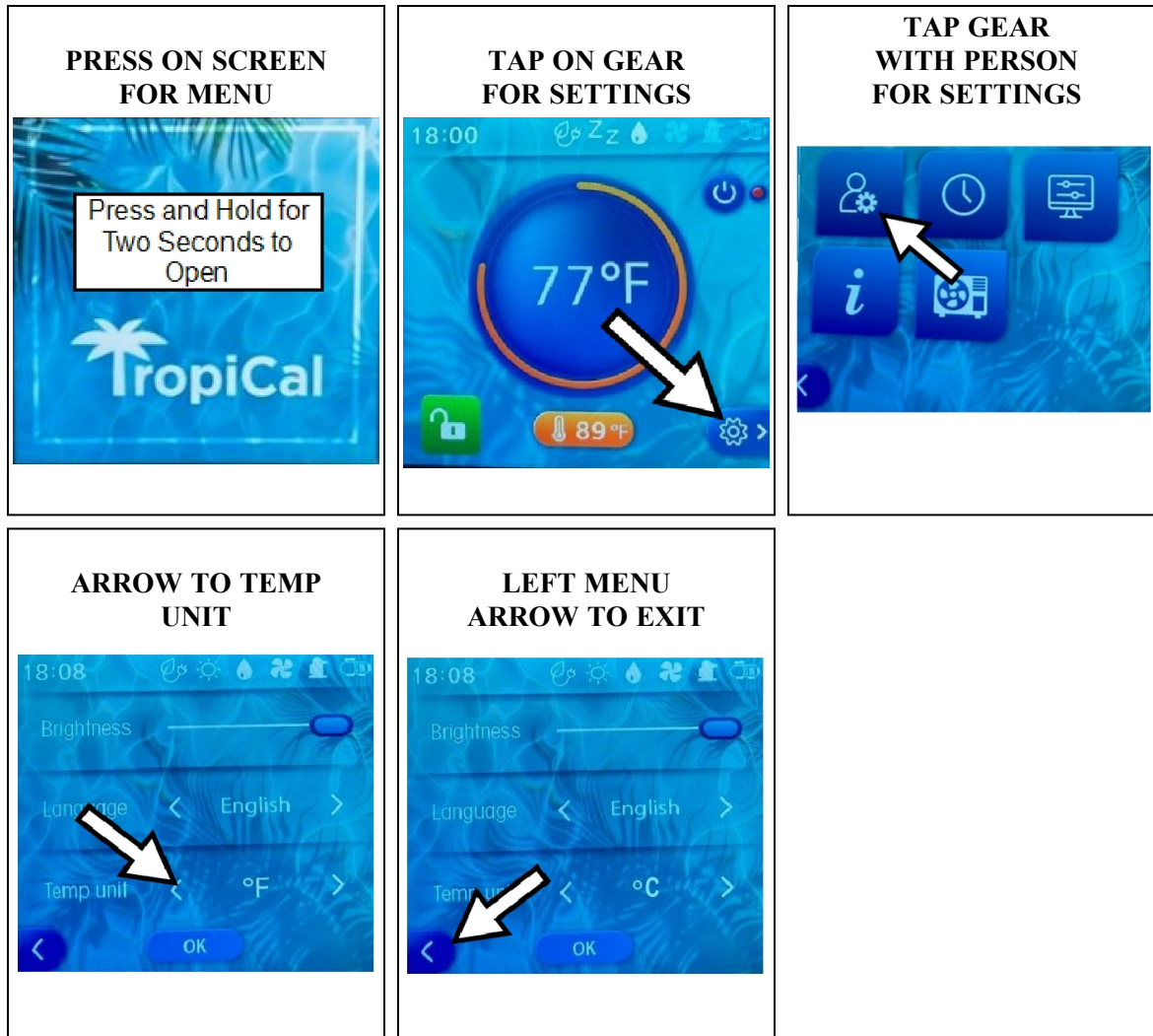

3.2.D Activate HEAT Mode, COOL Mode, or AUTO Mode

There are three available modes to heat or cool the water:

As the equipment modes are changed, indicators on the main screen will change. See "Example of Indicators at Top of Main Screen" on page 28.

HEAT MODE - Choose to heat the water.



When this mode is selected, the heat pump will activate and heat the water to a desired temperature set point. The indicator will display on the top of main screen for what is selected. The heat pump will continue to operate for another two minutes after the set point temperature is reached in order for the variable speed compressor to cycle down.

COOL MODE - Choose to cool the water.



When this mode is selected, the heat pump will activate and cool the water to a desired temperature set point. The indicator will display on the top of main screen for what is selected. The heat pump will continue to operate for another two minutes after the set point temperature is reached in order for the variable speed compressor to cycle down.

AUTO MODE - Choose to maintain a desired water temperature.



When this mode is selected the heat pump will activate and maintain a desired water temperature set point. The indicator will display on the top of main screen for what is selected. The heat pump will continue to operate for another two minutes after the set point temperature is reached in order for the variable speed compressor to cycle down.

PRESS ON SCREEN FOR MENU



TAP ON THERMOMETER



ARROW TO DESIRED MODE



LEFT MENU ARROW TO EXIT



3.2.E Set Efficiency Mode

The TropiCal line of Inverter driven heat pumps have three efficiency modes, allowing the user to fine tune the operation of the equipment for maximum efficiency.

- As the efficiency modes are set by the user, the indicators on the main screen will change. See "*Example of Indicators at Top of Main Screen*" on page 28.

Inverter heat pumps achieve maximum efficiency and progressively reduce the system speed as the water temperature approaches thermostats set points.

BOOST MODE - Choose the Boost mode.



In Boost Mode, the heat pump will operate between 85% to 100% of designed output.

- Boost provides full output for quickly heating a spa, initial heating of a cold pool, excessive heat loss recovery, and windy conditions.
- Users will set the heat pump to boost mode when fast heating is needed and then will typically switch the heat pump to Smart Mode or Eco Mode for increased efficiency.

SMART MODE - Choose the Smart mode.



In Smart Mode, the unit will operate between 55% to 100% of designed output.

- This allows for remarkably high efficiency, while maintaining the ability to operate at maximum output during heavy load conditions.

ECO-SILENT MODE - Choose Eco-Silent mode.



In Eco Silent Mode, the operation of the heat pump is limited to 30% to 55% of designed output.

- The system speed varies based on the differential or how close the water temperature is to the thermostat set point. By restricting the heat pump speed, the highest COP (coefficient of performance) or efficiency levels are achieved.
- Because operation is limited to 55%, the pool temperature may not recover quickly from overnight heat losses or ambient temperature fluctuations. Therefore the Eco Mode setting will not meet the needs of many customers.
- Eco Mode works best when the circulation system operates continuously and in climates that experience minimal heat loss. Pairing the Eco Mode with a Variable Speed circulation pump operating at a low and efficient speed is an ideal way to achieve the maximum total system efficiency.

PRESS ON SCREEN FOR MENU

Press and Hold for Two Seconds to Open



TAP ON THERMOMETER



ARROW TO DESIRED OPERATING MODE



LEFT MENU ARROW TO EXIT



3.2.F Setting Heat Pump Time of Day

PRESS ON SCREEN FOR MENU

Press and Hold for Two Seconds to Open



TAP ON GEAR



TAP ON CLOCK



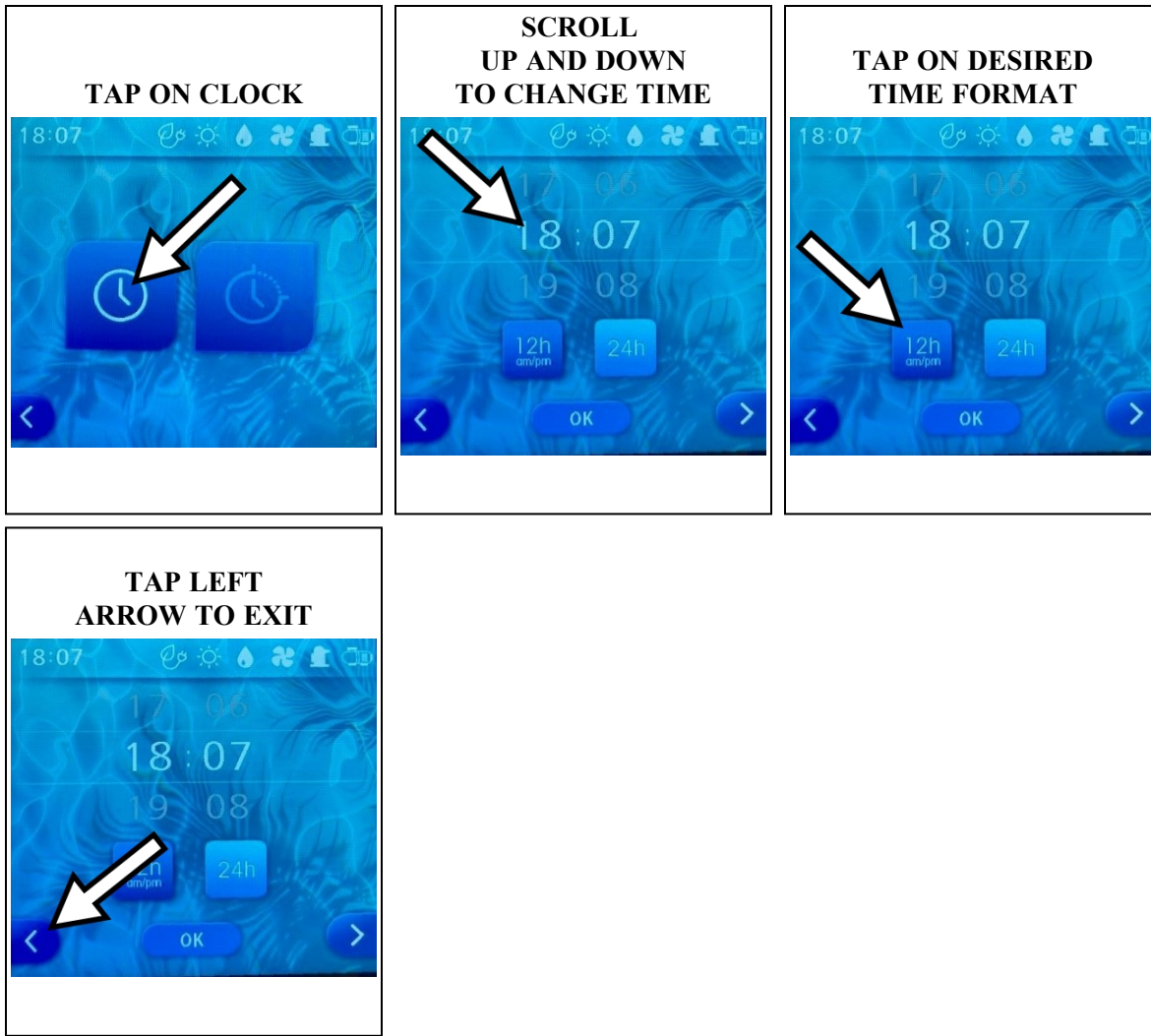

3.2.G Entry Lock Option

PLEASE NOTE -

- If the owner needs to lock out operation of the heat pump, an entry code can be used.

To Lock Heat Pump



**ENTER "0066"
FOR LOCKING**



TAP ENTER



**PRESS OK
TO CONFIRM**



**MAIN SCREEN
WILL INDICATE LOCK
IS ACTIVE**



To Unlock Heat Pump

**PRESS ON SCREEN
FOR MENU**



**TAP THE LOCK
BUTTON**

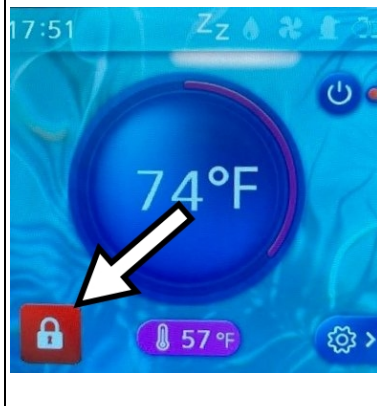

**TAP NUMBERS
TO ENTER CODE**

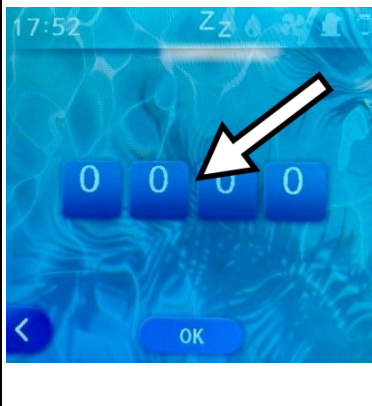

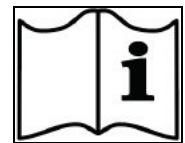
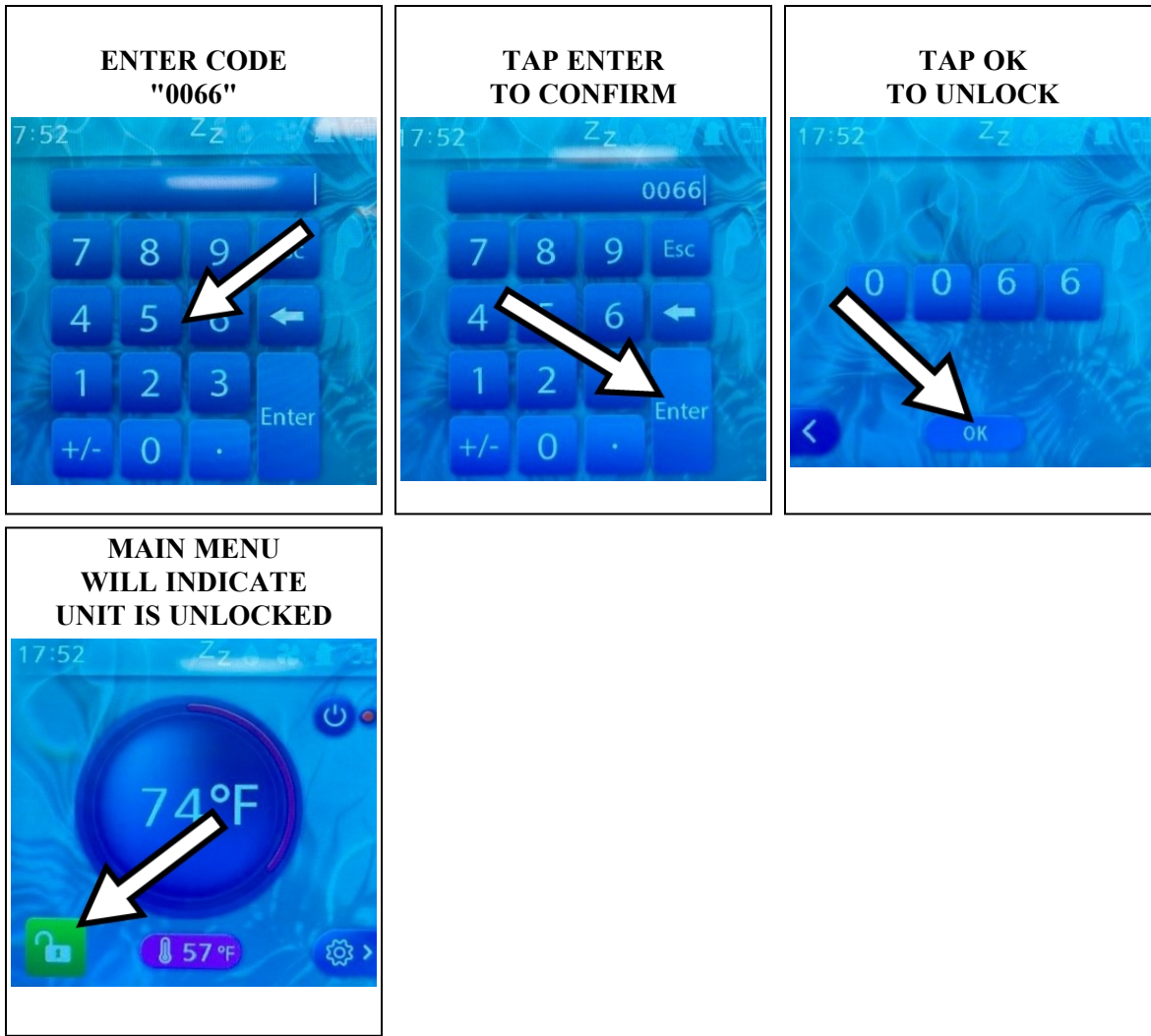

3.3 Optional Programming

IN THIS SECTION:

3.3.A The TropiCal® Heat Pump using WiFi	36
3.3.B Programming for Circulation Pump Extend Mode	37

3.3.A The TropiCal® Heat Pump using WiFi

The TropiCal® heat pump comes with internal WiFi that can be activated to control the heat pump remotely.

Please go to the website for specifics on configuring and using this feature.

<https://www.aquacal.com/inv-tropical/>

3.3.B Programming for Circulation Pump Extend Mode

The TropiCal[®] heat pump can extend the circulation pump run time to allow for longer operation times to meet set temperature.

1. Confirm the circulation pump has been properly connected to the heat pump. See "*Circulation Pump's Connection Point*" on page 24.
2. Turn the machine to standby mode (Red light illuminated)
3. Press the Gear Icon.
4. Press the "i" Icon.
5. Press the Gear Icon.
6. Press the Lock button.
7. Enter the code 0022. Press Enter then OK.
8. The parameter list will be shown with a lock in green.
9. Press the down arrow and go to parameter #9 in the left column.
10. Select the right column and enter the number for the mode the system should use, then press enter.
 - 0 = no extend feature,
 - 1 = extend run time to meet temperature
 - 2 = test every 60 minutes and turn on if setpoint is not met
11. After the selection is made press the lock button to retain the setting (lock will turn red).
12. Press the back arrow to return to the home screen.

IN THIS SECTION:

4.1 Service	38
4.1.A Service Personnel Qualifications	38
4.1.B Servicing Procedures	39
4.1.C Service Help	41
4.1.D Disposal of Heat Pump	42
4.2 Adjustments	43
4.2.A Cleaning Equipment	43
4.2.B Keeping the Filtration System Clean	44
4.2.C Maintenance	45
4.2.D Water Flow Adjustment Procedure	46
4.3 Supplemental	47
4.3.A Irrigation and Storm Run-Off	47
4.3.B Heating the water for the first time	47
4.3.C Pool Blankets	48
4.3.D Liquid Blankets	48
4.3.E Cooling the water for the first time	48
4.3.F Standards	49
4.3.G FCC Compliance	49
4.3.H Winterizing	50
4.4 System Information	52
4.4.A Dimensions	52
4.4.B Weights	53
4.4.C Identifying Model Specifications	53
4.4.D Operating Temperatures	54

4.1 Service



IN THIS SECTION:

4.1.A Service Personnel Qualifications	38
4.1.B Servicing Procedures	39
4.1.C Service Help	41
4.1.D Disposal of Heat Pump	42

4.1.A Service Personnel Qualifications

Qualifications

Only qualified service technicians should perform any work/ repairs on the heat pump.

- Information on procedures for servicing, installing, repairing, maintaining, and decommissioning procedures is required when working on an appliance with **FLAMMABLE REFRIGERANTS**. This is in addition to normal service, maintenance, and installation guidelines.
- The training of these procedures is only to be carried out by a nationally training organization or manufacturer accredited to teach these competency standards as set in local / national legislation. The achieved competence should be documented by a certificate.

Training Should Include the following

- Information about the explosive potential of FLAMMABLE REFRIGERANTS, and being dangerous if handled incorrectly.
- Information about POTENTIAL IGNITION SOURCES, especially those that are not obvious, such as lighters, light switches, vacuum cleaners, and electric heaters.
- Information about the different safety concepts when handling flammable refrigerants:
 - Safety of the appliance depends on ventilation of the housing.
 - Switching off the appliance or opening of the enclosure has a significant effect on the safety.
 - Care should be taken to ensure sufficient ventilation before servicing.
- Information about refrigerant detectors:
 - Principle of function, including influences on the operation of the equipment.
 - Procedures on how to repair, check or replace a refrigerant detector or parts of it in a safe way.
 - Procedures on how to disable a refrigerant detector in case of repair work on the refrigerant carrying parts.
- Information about sealed components and sealed enclosures.
- Information about correct working procedures. See "*Servicing Procedures*" below.
 - Commissioning
 - Maintenance
 - Repair
 - Decommissioning
 - Disposal

4.1.B Servicing Procedures



Failure to heed the following will result in injury or death.

- THIS EQUIPMENT CONTAINS SEMI-FLAMMABLE REFRIGERANT. Read the section entitled "FLAMMABLE REFRIGERANT" before servicing / installing this equipment. See "*Flammable Refrigerant*" on page 7.
- The heat pump utilizes high voltage and rotating equipment. Use caution when servicing.
- Heat Pump equipment must be installed within manufacturer specifications and must follow all National and/or State and Local installation guidelines.
- Follow all National Electric Codes (NEC) and/or State and Local guidelines.
- Confirm appropriate safety equipment is available and used appropriately while performing service or maintenance.



Failure to heed the following may result in minor or moderate injury.

- Servicing of this equipment by anyone other than a qualified technician can result in a safety hazard.

Commissioning

- Ensure that the area is prepared for working on a unit containing FLAMMABLE REFRIGERANT with proper ventilation.
- Connect the pipes and carry out a leak test before charging with refrigerant.
- Check safety equipment before putting into service Maintenance.

Maintenance

- Portable equipment shall be repaired outside or in a workshop specially equipped for servicing units with FLAMMABLE REFRIGERANTS.
- Ensure sufficient ventilation at the repair place.
- Be aware that malfunction of equipment may be caused by refrigerant loss and a refrigerant leak is possible.

- Discharge capacitors in a way that won't cause any spark. The standard procedure to short circuit the capacitor terminals usually creates sparks.
- Reassemble sealed enclosures accurately. If seals are worn, replace them.
- Check safety equipment before putting into service.

Repair

- Portable equipment shall be repaired outside or in a workshop specially equipped for servicing units with FLAMMABLE REFRIGERANTS.
- Ensure sufficient ventilation at the repair place.
- Be aware that malfunction of the equipment may be caused by refrigerant loss and a refrigerant leak is possible.
- Discharge capacitors in a way that won't cause any spark.
- When brazing is required, the following procedures shall be carried out in the following order:
- Safely remove the refrigerant following local and national regulations. If the recovery is not required by national regulations, drain the refrigerant to the outside. Take care that the drained refrigerant will not cause any danger. In doubt, one person should guard the outlet. Take special care that drained refrigerant will not float back into the building;
- Purge the refrigerant circuit with oxygen free nitrogen;
- Evacuate the refrigerant circuit;
- Purge the refrigerant circuit with nitrogen for 5 min (not required for A2L refrigerants).
- Evacuate again (not required for A2L refrigerants).
- Remove parts to be replaced by cutting or brazing.
- Purge the braze point with nitrogen during the brazing procedure required for repair
- Carry out a leak test before charging with refrigerant.

Decommissioning

- If safety is affected when the equipment is put out of service, the REFRIGERANT CHARGE shall be removed before decommissioning the equipment.
- Ensure sufficient ventilation at the equipment location.
- Be aware that a malfunction of the equipment may be caused by refrigerant loss and a refrigerant leak is possible.
- Discharge capacitors in a way that won't cause any spark
- Remove the refrigerant.
 - If the recovery is not required by national regulations, drain the refrigerant to the outside.

PLEASE NOTE

The Environmental Protection Agency (EPA) directs that refrigerant be recovered and not be released to the outside.

Follow all local and EPA requirements regarding handling of refrigerant.

- Take care that the drained refrigerant will not cause any danger.
- When in doubt, one person should guard the outlet. Taking special care that drained refrigerant will not float back into the building
- When FLAMMABLE REFRIGERANTS are used, evacuate the refrigerant circuit.
- Purge the refrigerant circuit with nitrogen for 5 min. -Evacuate again.
- Fill with nitrogen to atmospheric pressure.
- Put a label on the equipment that the refrigerant is removed.

Disposal

- Ensure sufficient ventilation at the work area.
- Remove the refrigerant. If the recovery is not required by national regulations, drain the refrigerant to the outside. Take care that the drained refrigerant will not cause any danger. In doubt, one person should guard the outlet. Take special care that drained refrigerant will not float back into the building.
- When flammable refrigerants are used,
 - Evacuate the refrigerant circuit.
 - Purge the refrigerant circuit with oxygen free nitrogen.
 - Evacuate again (not required for A2L refrigerants); and
 - Cut out the compressor and drain the oil.

Refrigerant pipe work

- The installation of pipe-work shall be kept to a minimum;
- Pipe-work including piping material, pipe routing, and installation shall include protection from physical damage in operation and service, and be in compliance with national and local codes and standards, such as ASHRAE 15, ASHRAE 15.2, IAPMO Uniform Mechanical Code, ICC International Mechanical Code, or CSA B52. All field joints shall be accessible for inspection prior to being covered or enclosed;
- After completion of field piping, the field pipework shall be pressure tested with an inert gas and then vacuum tested prior to refrigerant charging, according to the following requirements;
- The minimum test pressure for the low side of the system shall be the low side design pressure and the minimum test pressure for the high side of the system shall be the high side design pressure, unless the high side of the system, cannot be isolated from the low side of the system in which case the entire system shall be pressure tested to the low side design pressure.
- Field-made refrigerant joints indoors shall be tightness tested. The test method shall have a sensitivity of 5 grams per year of refrigerant or better under a pressure of at least 0,25 times the maximum allowable pressure. No leaks should be detected.

See "*Flammable Refrigerant*" on page 7 for more information on this section.

4.1.C Service Help

The following websites will help qualified service technicians service and repair heat pump equipment.

Ordering Parts - <https://www.aquacal.com/looking-for-a-part/>

4.1.D Disposal of Heat Pump



Refrigerant Safety
Group A2L

Failure to heed the following may result in injury or death.



When the heat pump reaches the end of its lifespan, and the owner does not wish to keep it, it **MUST NOT** be thrown out with household waste. It contains potentially hazardous substances that may harm the environment (as well as cause a fire) and that must, during recycling, be eliminated or neutralized. One of the following solutions should therefore be selected:

- Bring the Heat pump to a recycling center
- Give the Heat pump to a not-for-profit organization so that it can be repaired and reused
- Give the Heat pump to the shop when buying a new unit

4.2 Adjustments

IN THIS SECTION:

4.2.A Cleaning Equipment	43
4.2.B Keeping the Filtration System Clean	44
4.2.C Maintenance	45
4.2.D Water Flow Adjustment Procedure	46

4.2.A Cleaning Equipment

Installer - If you need to clean the equipment after installation, please use the following guidelines. Cleaning and polishing the heat pump regularly can protect its appearance and longevity. More frequent servicing may be required for heat pumps located in sandy or coastal areas where sand and salt spray can damage equipment.



WARNING

Failure to heed the following may result in injury or death.

- Possible electric shock hazard - Deactivate power to all electrical devices on the pad when washing heat pump. Do not restore electrical power until equipment is completely dry.

NOTICE

Failure to heed the following may result in damage to equipment.

- Do not use a pressure cleaner to wash the heat pump. Damage to heat pump components may result. If using a hose-end spray nozzle adjust the spray pattern to low strength only.
- Do not spray water directly into the interior of the heat pump; damage to components may result.
- Do not use chemicals on the display panel.

Cleaning

1. Wash cabinet using a low-pressure water hose. A high-pressure water stream will cause damage to the aluminum fins of the heat pump. This damage is not covered under the product warranty.
2. While the heat pump is still wet, use an approved cleaning agent to clean the exterior of the heat pump. **Do not use chemicals on the display panel.**
3. Use a detergent-dampened cloth to wipe the heat pump's exterior cabinet.
4. Flush all exterior with fresh water using a low-pressure water hose.
5. Dry the cabinet using a soft cloth being careful not to damage fins.

APPROVED CLEANING AGENTS*

Fantastic®

Formula 409®

Cascade®

All Power Plain Detergent (3% Solution)

Table 1 - Cleaning Agents

- * The trademarks used in approved cleaning agents are the property of their owners and are not related to AquaCal®.

Polishing

1. Polish the heat pump's cabinet panels using an approved polishing agent and following the manufacturer's instructions. **Do not use chemicals on the display panel.**
2. Rinse the heat pump panels with fresh water, wipe, and buff panels using a dry soft cloth.
3. Allow heat pump interior and surrounding equipment to "air-dry" for several hours prior to restoring electrical power.

APPROVED POLISHING AGENTS*
Simoniz® Wax
Glo-Coat®
Armor All® Protectant

Table 2 - Polishing Agents

- * The trademarks used in approved polishing agents are the property of their owners and are not related to AquaCal®.

4.2.B Keeping the Filtration System Clean

The following should be done to avoid blockages that will impede heat pump performance:

- Confirm leaf basket clean and free of debris.
- Confirm skimmer baskets are clean and free of debris.
- Confirm any filter medium (sand, cartridge) has recently been cleaned.
- Confirm the level of water within the swimming pool is correct. The level should be half way across the face of the skimmer.
- The water pressure from the jets / outlets to the swimming pool should appear to be normal. If not, check system for further blockages.

4.2.C Maintenance

An annual inspection and maintenance program is strongly recommended starting no later than one year after installation of the heat pump. In harsh environments or coastal areas, a bi-annual inspection is recommended. See the recommended inspection checklist.

DANGER

Failure to heed the following will result in injury or death.

- Deactivate power while routing wiring to control board.
- Heat Pump equipment must be installed within manufacturer specifications and must follow all National and/or State and Local installation guidelines.
- Follow all National Electric Codes (NEC) and/or State and Local guidelines.

WARNING

Failure to heed the following may result in injury or death.

- Annual inspection and service must be performed by a qualified heat pump specialist in order to prevent physical injury or damage to equipment. For tasks requiring handling refrigerant, an HVAC license is required.

Recommended Inspection Checklist:

1. Clean Evaporator Coil (As Applicable)
2. Check Fan Blade Clearances
3. Clean Heat Pump Cabinet
4. Check Flow / Pressure Switch
5. Apply Rust Inhibitors (As applicable)
6. Verify / Check Air Flow Delta-T
7. Verify / Check Water Flow Delta-T
8. Check Fan Motor Amperage Draw
9. Check and Clear Condensate Drains
10. Check Compressor Amperage Draw
11. Check Internal Electrical Connections
12. Check Operating Refrigerant Pressures (As Applicable)
13. Check Ambient and Water Temperature Sensors
14. Check Proper Line and Control Voltage to Unit
15. Identify Insect and Rodent Issues with Unit
16. Identify Environmental Conditions of Concern (Run-Off, Sprinklers, etc.)
17. Perform Operating Orientation (As Applicable)

4.2.D Water Flow Adjustment Procedure

To optimize the heating or cooling performance, and achieve power savings, the water flow through the heat pump should be adjusted. The water flow through the heat pump and the gas pressure in the device are directly related to heat pump performance.

1. Confirm the isolation valves are fully open to the heat pump.
2. With the heat pump off and the circulation pump running, note the pressure on the outer scale of the pressure gauge located on the back of the unit.

Outer Ring (in PSI)



Outer Ring (in MPa)



3. Start the unit in Boost mode and allow it to run for at least five minutes.
4. Adjust the bypass valve so the pressure rise is 87 – 131 PSI (.6 to .9 MPa) higher than the starting pressure.
 - Opening the bypass will raise the pressure.
 - Closing the bypass will lower the pressure.
5. A final adjustment should be made when the pool water temperature is close to the temperature setpoint.

Bypass (Jandy shown)

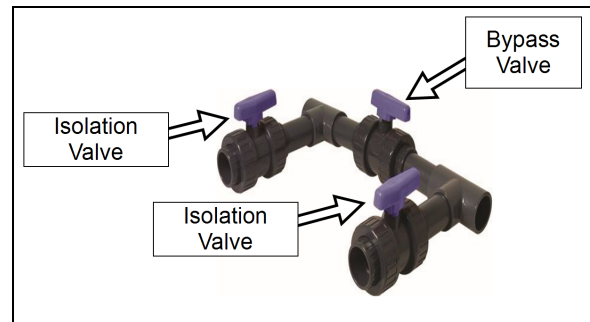

Further adjustments required:

The required flow through the heat pump depends on the water temperature, and to a lesser extent, on air temperature. It should be adjusted:

- When the heat pump is first started and the water is cold.
- Re-checked during a rise of temperature upon start up.
- Final adjustments if needed, when at the desired water temperature.
- There should then be no reason to subsequently adjust water flow after the preliminary adjustments have been made.

4.3 Supplemental

IN THIS SECTION:

4.3.A Irrigation and Storm Run-Off	47
4.3.B Heating the water for the first time	47
4.3.C Pool Blankets	48
4.3.D Liquid Blankets	48
4.3.E Cooling the water for the first time	48
4.3.F Standards	49
4.3.G FCC Compliance	49
4.3.H Winterizing	50

4.3.A Irrigation and Storm Run-Off

- Irrigation water may damage heat pump components. Direct irrigation water away from the heat pump.
- The heat pump will withstand normal rainfall. Do not allow a roof slope to direct rainwater onto the heat pump. Have a gutter installed on the roof edge to direct this water away from the heat pump. Or install the heat pump in another location.

4.3.B Heating the water for the first time

The following recommendations will reduce the amount of time required to heat a pool.

If using a pool time clock:

1. If connected to the heat pump, confirm the circulation pump is activated.
 - If no direct connection to the circulation pump is set, set circulation pump time clock to 24 hours.
2. Confirm valves are positioned correctly.
3. Confirm that the correct heat / cool mode has been selected.
4. Set the desired temperature "HEAT SETPOINT" for the water.
5. Activate Boost Mode.
6. Use a pool cover or blanket to reduce heating time.
7. After the desired temperature has been reached, adjust the circulation pump run time and time clock as needed to maintain temperature.
8. The system can now be set to Smart Mode or Eco Mode for lower operating costs while maintaining temperature.

If heat pump has been configured to directly control the circulation pump:

1. Confirm the mode has been set to "HEAT" mode.
2. Set the desired temperature "HEAT SETPOINT" for the water.
3. If a circulation pump has been connected to the heat pump, it will automatically activate and continue to operate until the set temperature is met.

4.3.C Pool Blankets

A pool blanket can assist the heater to maintain water temperature while significantly reducing heating costs. Conventional blankets, commonly referred to as "Solar Blankets", are a thin plastic-like membrane that floats on the water surface. To be effective solar blankets are physically placed over the water surface when the pool is not in use.

WARNING

Failure to heed the following may result in injury or death.

- Improperly used, Pool-Spa solar blankets can become a drowning risk to people and pets. Solar blankets are not safety covers. They are not designed to support the weight of a person or pet. Never enter a pool until the solar cover is completely removed. Under no circumstances should anyone swim under the blanket. Follow all safety recommendations of the blanket manufacturer.

Pools typically lose 50% of the heat added to the pool by the heater and / or sunlight.

- Blanketed pools will typically lose only 3° - 4° F of heat per night.
- This is compared to a typical heat loss of 8° - 10° F for a non-blanketed pool.

4.3.D Liquid Blankets

For those who want to save on heating costs, but do not want the bother and potential dangers of a conventional blanket, a liquid blanket such as the Aqua Blanket™ available thru Lo-Chlor®, can be a viable alternative. A liquid-blanketed pool on average loses only 30% of its heat gain overnight. However, strong winds can reduce the effectiveness of liquid blankets. Check your pool dealer / supplier for more information on pool blankets and liquid blankets.

4.3.E Cooling the water for the first time

The following recommendations will reduce the amount of time required to cool a pool.

If using a pool time clock:

1. If connected to the heat pump, confirm the circulation pump is activated.
 - If no direct connection to the circulation pump is set, set circulation pump time clock to 24 hours.
2. Confirm valves are positioned correctly.
3. Confirm that the correct heat / cool mode has been selected.
4. Set the desired temperature "COOL SETPOINT" for the water.
5. Activate Boost Mode.
6. After the desired temperature has been reached, adjust the circulation pump run time and time clock as needed to maintain temperature.
7. The system can now be set to Smart Mode or Eco Mode for lower operating costs while maintaining temperature.

If heat pump has been configured to directly control the circulation pump:

1. Confirm the mode has been set to "COOL" mode.
2. Set the desired temperature "COOL SETPOINT" for the water.
3. If a circulation pump has been connected to the heat pump, it will automatically activate and continue to operate until the set temperature is met.

4.3.F Standards

Conforms To

UL STD 60335-2-40

Certified To

CSA STD C22 .2 #60335-1 and 60335-2-40

4.3.G FCC Compliance

NOTE

Changes or modifications not expressly approved by the party responsible for compliance could void the user's authority to operate the equipment.

This device has been tested and complies with part 15 of the FCC rules. Operation is subject to the following two conditions

1. This device may not cause harmful interference, and
2. This device must accept any interference received, including interference that may cause undesired operation.

These limits are designed to provide reasonable protection against harmful interference in a residential installation. This equipment generates, uses and can radiate radio frequency energy and, if not installed and used in accordance with the instructions, may cause harmful interference to radio communications. However, there is no guarantee that interference will not occur in a particular installation. If this equipment does cause harmful interference to radio or television reception, which can be determined by turning the equipment off and on, the user is encouraged to try to correct the interference by one or more of the following measures:

- Reorient or relocate any connected PoolSync®'s receiving antenna.
- Increase the separation between the equipment and any connected PoolSync®'s receiver.
- Connect the equipment into an outlet on a circuit different from that to which the receiver is connected.
- Consult the dealer or an experienced radio / TV technician for help.

4.3.H Winterizing

Failure to properly winterize the heat pump as needed may result in serious equipment damage.

DANGER

Failure to heed the following will result in injury or death.

- Deactivate power while routing wiring to control board.
- Heat Pump equipment must be installed within manufacturer specifications and must follow all National and/or State and Local installation guidelines.
- Follow all National Electric Codes (NEC) and/or State and Local guidelines.

WARNING

Failure to heed the following may result in injury or death.

- Deactivate all electrical power to heat pump before performing hard freeze procedures.

NOTICE

Failure to heed the following may result in damage to equipment.

- Failure to winterize heat pump may result in serious equipment damage. Freeze damage is not covered under the heat pump warranty.
- While the plumbing connections are in the winterized condition (not fully tightened), it is imperative that water not run through the heat pump. Loss of water through loose plumbing connections may result in damage to circulation pump, pool and spa structures, and other equipment.

Light Freeze Conditions

A light freeze is when the ambient air temperature falls below 32 degrees Fahrenheit (0° C) for less than 8 hours. Typically during light freeze conditions circulating (or moving) water will not freeze. Temporarily activate the filter pump for continuous operation during light freeze conditions.

Hard Freeze Conditions

A hard freeze is when the ambient air temperature falls below 32 degrees Fahrenheit (0° C) for more than 8 hours. In areas where this condition is prevalent and sustained, the heat pump **MUST** be winterized for hard freeze conditions. Follow the procedure for winterizing the equipment.

Diagram Showing Open Valves

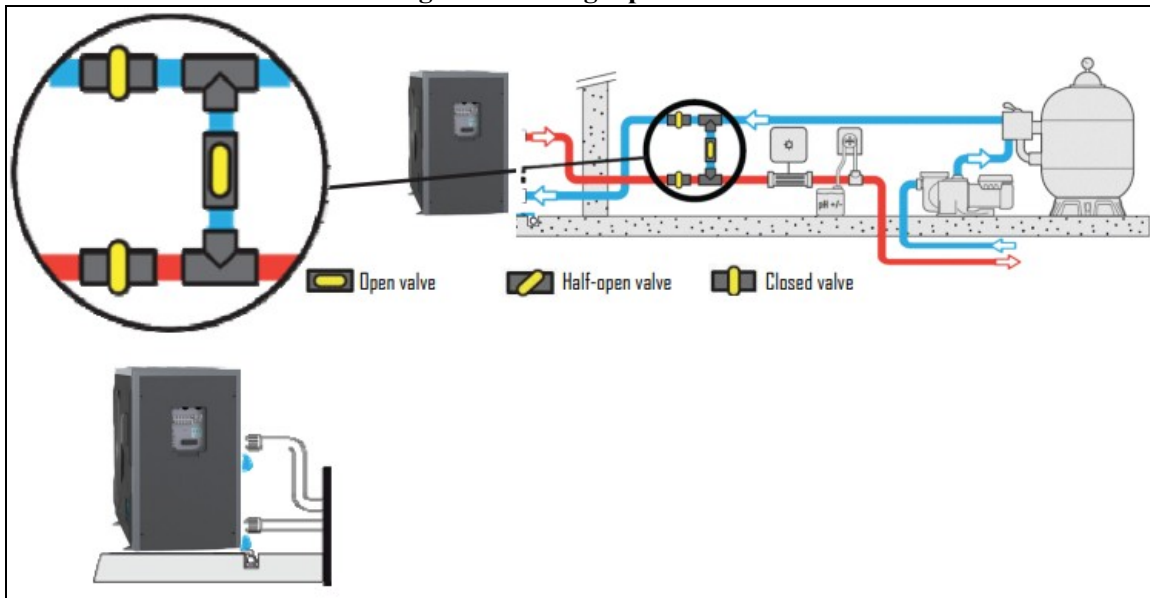

1. Deactivate all electrical power to heat pump.
2. Deactivate the filter pump.
3. Close any open valves to heat pump.
4. Disconnect the plumbing to the heat pump at all connection unions and caps (removal is counter-clockwise).
5. Allow water to drain completely from the heat pump. Expect to see a lot of water to drain out at first, and then a small amount to continue to drain out over a long period.
6. After heat pump is fully drained, loosely reconnect plumbing connection unions and caps to prevent pest infestation.
7. If removing unit from pad to store, confirm storage area does not contain an ignition source and that a no-smoking sign is present. See "*Flammable Refrigerant* " on page 7.
8. Cover or plug both the heat pump and plumbing lines to prevent pest infestation.
9. Winterizing is complete.

When hard freeze conditions are over, use the following procedure to bring the heat pump back into service:

10. If the heat pump was removed from the pad, properly place the unit on the pad and insure it is level and properly anchored to the pad.
11. If used, reconnect the condensation drain hose.
12. Hand-tighten connection unions
13. Reconnect electrical power.
14. Reposition valves for proper water flow.
15. Set the operating mode on the heat pump.
16. Activate the filter pump.

4.4 System Information

IN THIS SECTION:

4.4.A Dimensions	52
4.4.B Weights	53
4.4.C Identifying Model Specifications	53
4.4.D Operating Temperatures	54

4.4.A Dimensions

TropiCal® T70, T100

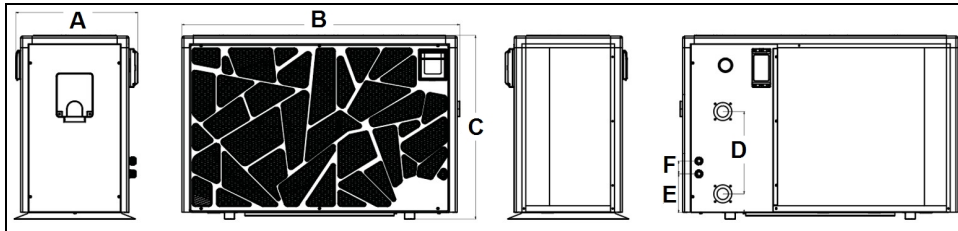

Model	A	B	C	D	E	F
T70	1 ft 6 in (474 mm)	3 ft 6 in (1080 mm)	2 ft 4 in (715 mm)	1 ft (320 mm)	6 in (150 mm)	2 in (50 mm)
T100	1 ft 8 in (518 mm)	3 ft 10 in (1178 mm)	2 ft 10 in (872 mm)	1 ft 5 in (430 mm)	8 in (210 mm)	2 in (50 mm)

TropiCal® T130

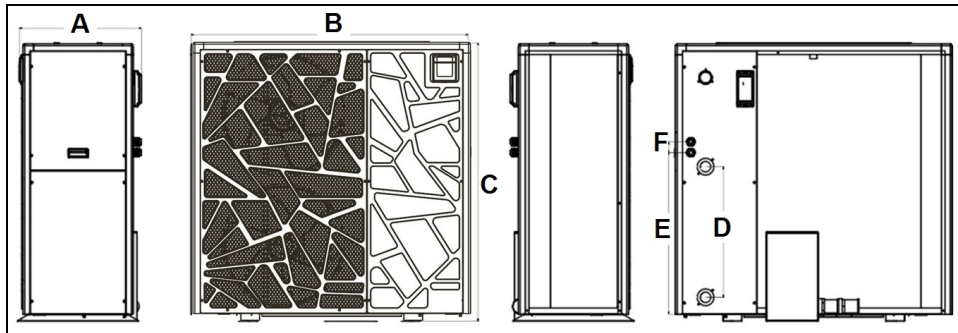

Model	A	B	C	D	E	F
T130	1 ft 8 in (514 mm)	3 ft 10 in (1166 mm)	3 ft 10 in (1171 mm)	1 ft 10 in (550 mm)	2 ft 2 in (681 mm)	1.5 in (45 mm)

4.4.B Weights

NOTE:

Specifications subject to change.

Model Type	Model Number	Install Weight
TropiCal®	T70	139 Pounds (63 kg)
TropiCal®	T100	207 Pounds (94 kg)
TropiCal®	T130	271 Pounds (123 kg)

4.4.C Identifying Model Specifications

1. Find Data Plate - The data plate is usually posted on the side of the equipment or the inside of the heat pump's access plate.
2. Find the model number on the data plate. The first letters and numbers indicate the model type.
3. The complete model number identifies the equipment's specifications.

4.4.D Operating Temperatures

The ambient air sensor (located on the back of the heat pump) is used to efficiently control heat pump components during heating or cooling of the water. The heat pump has an operational air temperature range between 5° to 109° F (-15° to 43° C).

If the outside air falls out of that range, the heat pump will temporarily halt until the temperature normalizes.

Ambient Air Sensor



PLEASE NOTE:

Additional factors and conditions including relative humidity, unit placement, direct sun exposure, and poor air circulation around the unit may the heat pump to deactivate and display a fault. See the AL14 fault code in troubleshooting for more information. See "Fault Codes" on page 57.



5 - Troubleshooting

DANGER

Failure to heed the following will result in injury or death.

- Deactivate power while routing wiring to control board.
- Heat Pump equipment must be installed within manufacturer specifications and must follow all National and/or State and Local installation guidelines.
- Follow all National Electric Codes (NEC) and/or State and Local guidelines.

WARNING

Failure to heed the following may result in injury or death.

- Repairs must not be attempted by untrained or unqualified individuals.
- The heat pump contains refrigerant under high pressure. Repairs to the refrigerant circuit must not be attempted by untrained or unqualified individuals. Service must be performed only by qualified HVAC technicians. Recover refrigerant before opening the system.

NOTICE

Failure to heed the following may result in damage to equipment.

- Service by unauthorized personnel will void the heat pump warranty.

IN THIS SECTION:**Fault Codes**

LOW - Low or No Water Flow	57
AL01 - Discharge Temp Sensor Failure	57
AL02 - Suction Temp Sensor Failure	57
AL03 - Inlet Water Temp Sensor Failure	57
AL04 - Outlet Water Temp Sensor Failure	58
AL05 - Coil Temp Sensor Failure	58
AL06 - Ambient Air Temp Sensor Failure	58
AL07 - Display Communication Error	58
AL08 - EEPROM Error	58
AL09 - Fan Error	59
AL10 - High Pressure Protection	59
AL11 - High Pressure Protection 3 Times	59
AL12 - Low Pressure Protection	60
AL13 - Low Pressure Protection 3 Times	60
AL14 - Outdoor Ambient Air Temperature Is Too Low or High	61
AL15 - Too High a Difference Between Inlet and Outlet Water Temperatures	61
AL16 - Too High a Difference Between Inlet and Outlet Water Temperatures - 3 times	61
AL17 - Ambient air too cold	62
AL18 - Compressor Protection - Too High Discharge Temperature	62
AL19 - Voltage Protection - Too High or Too Low	62
AL20 - Current Protection - Too High or Too Low	62
AL21 - DC Busbar Voltage Protection	62
AL22 - Compressor Over-Current Protection	63
AL23 - IPM Temperature Too High	63
AL24 - The IPM Has Detected an Error	63
AL25 - Compressor Driver Protection	63
EA01 - Over Current Protection - Rise in Frequency Speed-Up	63
EA02 - Over Current Protection - Drop in Frequency Slow-Down	64
EA03 - Over Current Protection - Constant Speed	64
EA04 - Over Voltage Protection - Frequency Rise Speed-Up	64
EA05 - Over Voltage Protection - Frequency Down Slow-Down	64
EA06 - Over Voltage Protection - Constantly Speed	64
EA07 - Communication Error - Drive to Microcontroller	64
EA08 - Lose Step Error	65
EA09 - Lose Phase Error	65
EA10 - Intelligent power module (IPM) hardware protection	65
EA19 - Current Test - Circuit Error	65

Issues and resolutions

Blank Display	65
Circulation Pump Won't Activate	66
Heat Pump Not Running	66
Heat Pump Won't Deactivate	67
Heat Pump Is Running, Not Heating	67
Heat Pump Is Running, Not Cooling	68
Ice Forming on the Heat Pump	68
Unable to Connect Using Wi-Fi	69
Water Coming From Heat Pump	69

5.1 Fault Codes

A fault code indicates a specific issue or condition that will require action before the equipment can resume operating.

Please perform the following troubleshooting.

LOW - Low or No Water Flow

ISSUE

Low or no water detected. This is normal when the circulation pump is deactivated.

RESOLUTION

1. Confirm the filter pump is on.
2. Confirm the filtration system is clean. See "*Keeping the Filtration System Clean*" on page 44.
3. If a multiple-speed filter pump is being used, run at a higher speed to determine if the error persists. Do not exceed the maximum flow rate for your model.
 - See "*Water Flow Rates*" on page 20.
4. Confirm water is not being diverted away from the heat pump.
5. The unit is connected to an external controller and there is no "call for heating" or signal from the controller.
6. The unit is not connected to an external controller, but the white jumper wire has been removed. See "*Remove the jumper from the On / Off terminals.*" on page 25.
7. If the issue persists, please contact the installing dealer for service.

AL01 - Discharge Temp Sensor Failure

ISSUE

Discharge Temperature Sensor Failure

RESOLUTION

1. A qualified technician should evaluate the unit.
2. Please contact the installing dealer for service.

AL02 - Suction Temp Sensor Failure

ISSUE

Suction Temperature Sensor Failure

RESOLUTION

1. A qualified technician should evaluate the unit.
2. Please contact the installing dealer for service.

AL03 - Inlet Water Temp Sensor Failure

ISSUE

Inlet Water Temperature Sensor Failure

RESOLUTION

1. A qualified technician should evaluate the unit.
2. Please contact the installing dealer for service.

AL04 - Outlet Water Temp Sensor Failure**ISSUE**

Outlet Water Temperature Sensor Failure

RESOLUTION

1. A qualified technician should evaluate the unit.
2. Please contact the installing dealer for service.

AL05 - Coil Temp Sensor Failure**ISSUE**

Coil Temperature Sensor Failure

RESOLUTION

1. A qualified technician should evaluate the unit.
2. Please contact the installing dealer for service.

AL06 - Ambient Air Temp Sensor Failure**ISSUE**

Ambient Air Temperature Sensor Failure

RESOLUTION

1. A qualified technician should evaluate the unit.
2. Please contact the installing dealer for service.

AL07 - Display Communication Error**ISSUE**

The Heat Pump is unable to communicate with the display board.

RESOLUTION

1. Power cycle the heat pump at the breaker panel.
2. If this does not resolve the issue, a qualified technician should verify the connection between the control board and the display (loose or disconnected cable, crimps in the cable, etc.).
3. Please contact the installing dealer for service.

AL08 - EEPROM Error**ISSUE**

The Heat Pump's EEPROM on the power control board is not communicating.

RESOLUTION

1. Power cycle the heat pump at the breaker panel to see if issue persists.
2. If this does not resolve the issue, a qualified technician should evaluate the unit.
3. Please contact the installing dealer for service.

AL09 - Fan Error

ISSUE

The Heat Pump's fan may not be working properly.

RESOLUTION

1. Power cycle the heat pump at the breaker panel to see if issue persists.
2. A qualified technician should check fan connections and operation.
3. Please contact the installing dealer for service.

AL10 - High Pressure Protection

ISSUE

The refrigerant system's high-pressure switch is showing as open.

RESOLUTION

1. Deactivate the heat pump and wait for 2-5 minutes. Note the pressure indicated on the manometer (usually located at the back of the system).
2. Once noted, re-start the system and note the maximum pressure achieved and indicated by the needle on the manometer.
3. Call for service if the pressure indicated on the manometer surpasses 38 bar on the gauge and the heat pump deactivates with an error.
4. Place the heat pump in heating mode and perform the following troubleshooting.
5. Determine if the proper amount of water flow is being provided to the equipment.
 - a. Confirm the filter pump is on.
 - b. If a multiple-speed filter pump is being used, run filter pump at a higher speed. Do not exceed the maximum flow rate for the model.
 - See "*Water Flow Rates*" on page 20.
 - c. Confirm water is not being diverted away from the heat pump.
 - d. Confirm valves are in the correct position.
 - See "*Water Flow Adjustment Procedure*" on page 46.
6. If the issue persists, please contact the installing dealer for service.

AL11 - High Pressure Protection 3 Times

ISSUE

The heat pump has had a high pressure protection occur three times. The system is locked until the issue is corrected.

RESOLUTION

1. Troubleshoot the high-pressure issue causing the error. See AL10 troubleshooting.
2. Reset power at the power breaker.
3. If the issue persists, please contact the installing dealer for service.

AL12 - Low Pressure Protection

ISSUE

The refrigerant system's low-pressure switch is showing as open.

RESOLUTION

1. Confirm water temperature is above 50° F (10° C)
 - If not above 50° F(10° C), the system may be out of its defined operating range.
 - Swimming pool water is either too cold or too hot.
 - Outside ambient air temperature is either too cold or too hot.
 - Verify that the two above temperatures are within the systems defined parameters before proceeding.
2. With the system turned off, verify the refrigerant (Gas) pressure on the manometer is within an acceptable range (in the green). If the pressure indicated is near zero bars, call for service.
3. Verify for proper fan operation. If the fan is not operating, call for service.
4. Check for obstructed airflow around the heat pump.
 - See "Clearances".
5. Check for a dirty or blocked evaporator coil.
 - See "*Cleaning Equipment*" on page 43.
6. Check for signs of heavy ice buildup on the coil.
 - See "*Winterizing*" on page 50.
7. If the issue persists, please contact the installing dealer for service.

AL13 - Low Pressure Protection 3 Times

ISSUE

The heat pump has had a low pressure protection occur three times. The system is locked until the issue is corrected.

RESOLUTION

1. Troubleshoot the low-pressure issue causing the error. See AL12 troubleshooting.
2. Reset power at the power breaker.
3. If the issue persists, please contact the installing dealer for service.

AL14 - Outdoor Ambient Air Temperature Is Too Low or High**ISSUE**

The ambient air sensor is reporting temperatures are too cold or too hot to properly operate the heat pump.

RESOLUTION

1. Confirm ambient air temperature is within range for proper operation of the equipment. The outside air temperature must be within 5° to 109° F (-15° to 43° C) in order to operate properly.
2. If the temperature is too cold, winterizing the equipment may become necessary. See "*Winterizing*" on page 50.
3. If the air temperature is too hot, and outside the operating heat pump's required operating temperatures, the heat pump will deactivate. The heat pump will re-activate again once air temperatures normalize. See "*Operating Temperatures*" on page 54.
4. If the outside air temperature is within range, but the heat pump sensor is indicating it is too hot, check to see if direct sunlight is heating the sensor prematurely. A sensor shade may be necessary.
5. If ambient air temperature is within normal operating range, a technician may need to evaluate the unit.
6. Please contact the installing dealer for service.

AL15 - Too High a Difference Between Inlet and Outlet Water Temperatures**ISSUE**

The water temperature coming into and out of the heat pump must be within a defined range in order to operate properly.

Check if conditions are allowing these two temperatures to fall outside the proper range (too far apart).

RESOLUTION

1. Confirm water circulation pump is operating.
2. Check for obstructions to filtration system (debris in baskets, etc.) Clean filtration system if needed.
3. Adjust valves for proper water flow to heat pump.
4. If the issue persists, please contact the installing dealer for service.

AL16 - Too High a Difference Between Inlet and Outlet Water Temperatures - 3 times**ISSUE**

The water temperature coming into and out of the heat pump has been outside a defined range at least 3 times. The heat pump has locked to protect equipment.

RESOLUTION

1. Power cycle equipment and then run troubleshooting for AL15 code.
2. If the issue persists, please contact the installing dealer for service.

AL17 - Ambient air too cold**ISSUE**

The ambient air sensor is reporting that the air is too cold when operating the heat pump in cooling mode.

- The operating temperature of the heat pump is 5° to 109° F (-15° to 42° C).

RESOLUTION

1. Confirm ambient air temperature is within range for proper operation of the equipment.
2. Winterize equipment if needed. See "*Winterizing*" on page 50.
3. If ambient air temperature is within normal operating range, a technician may need to evaluate the unit.
4. Please contact the installing dealer for service.

AL18 - Compressor Protection - Too High Discharge Temperature**ISSUE**

The heat pump is reporting a condition that may damage the compressor.
The heat pump has been deactivated until condition is resolved.

RESOLUTION

1. A qualified technician should evaluate the Heat Pump.
2. Please contact the installing dealer for service.

AL19 - Voltage Protection - Too High or Too Low**ISSUE**

The heat pump is reporting a condition that could damage the equipment.

RESOLUTION

1. A qualified technician should evaluate the Heat Pump.
2. Please contact the installing dealer for service.

AL20 - Current Protection - Too High or Too Low**ISSUE**

The heat pump is reporting a condition that could damage the equipment.

RESOLUTION

1. A qualified technician should evaluate the Heat Pump.
2. Please contact the installing dealer for service.

AL21 - DC Busbar Voltage Protection**ISSUE**

The heat pump is reporting a condition that could damage the equipment.

RESOLUTION

1. A qualified technician should evaluate the Heat Pump.
2. Please contact the installing dealer for service.

AL22 - Compressor Over-Current Protection**ISSUE**

The heat pump is reporting an issue that could damage the compressor.

The heat pump has been locked.

RESOLUTION

1. A qualified technician should evaluate the Heat Pump.
2. Please contact the installing dealer for service.

AL23 - IPM Temperature Too High**ISSUE**

Intelligent Power Module (IPM) has detected the IPM temperature is too high.

RESOLUTION

1. A qualified technician should evaluate the Heat Pump.
2. Please contact the installing dealer for service.

AL24 - The IPM Has Detected an Error**ISSUE**

Intelligent Power Module (IPM) has detected an issue that could damage the heat pump.

The heat pump has been locked.

RESOLUTION

1. A qualified technician should evaluate the Heat Pump.
2. Please contact the installing dealer for service.

AL25 - Compressor Driver Protection**ISSUE**

The heat pump is reporting an issue that could damage the compressor.

The heat pump has been locked.

RESOLUTION

1. A qualified technician should evaluate the Heat Pump.
2. Please contact the installing dealer for service.

EA01 - Over Current Protection - Rise in Frequency Speed-Up**ISSUE**

The heat pump is reporting a condition that could damage the equipment.

RESOLUTION

1. A qualified technician should evaluate the Heat Pump.
2. Please contact the installing dealer for service.

EA02 - Over Current Protection - Drop in Frequency Slow-Down**ISSUE**

The heat pump is reporting a condition that could damage the equipment.

RESOLUTION

1. A qualified technician should evaluate the Heat Pump.
2. Please contact the installing dealer for service.

EA03 - Over Current Protection - Constant Speed**ISSUE**

The heat pump is reporting a condition that could damage the equipment.

RESOLUTION

1. A qualified technician should evaluate the Heat Pump.
2. Please contact the installing dealer for service.

EA04 - Over Voltage Protection - Frequency Rise Speed-Up**ISSUE**

The heat pump is reporting a condition that could damage the equipment.

RESOLUTION

1. A qualified technician should evaluate the Heat Pump.
2. Please contact the installing dealer for service.

EA05 - Over Voltage Protection - Frequency Down Slow-Down**ISSUE**

The heat pump is reporting a condition that could damage the equipment.

RESOLUTION

1. A qualified technician should evaluate the Heat Pump.
2. Please contact the installing dealer for service.

EA06 - Over Voltage Protection - Constantly Speed**ISSUE**

The heat pump is reporting a condition that could damage the equipment.

RESOLUTION

1. A qualified technician should evaluate the Heat Pump.
2. Please contact the installing dealer for service.

EA07 - Communication Error - Drive to Microcontroller**ISSUE**

The heat pump is reporting a condition that could damage the equipment.

RESOLUTION

1. A qualified technician should evaluate the Heat Pump.
2. Please contact the installing dealer for service.

EA08 - Lose Step Error**ISSUE**

The heat pump is reporting a condition that could damage the equipment.

RESOLUTION

1. A qualified technician should evaluate the Heat Pump.
2. Please contact the installing dealer for service.

EA09 - Lose Phase Error**ISSUE**

The heat pump is reporting a condition that could damage the equipment.

RESOLUTION

1. A qualified technician should evaluate the Heat Pump.
2. Please contact the installing dealer for service.

EA10 - Intelligent power module (IPM) hardware protection**ISSUE**

The heat pump is reporting a condition that could damage the equipment.

RESOLUTION

1. A qualified technician should evaluate the Heat Pump.
2. Please contact the installing dealer for service.

EA19 - Current Test - Circuit Error**ISSUE**

The heat pump is reporting a condition that could damage the equipment.

RESOLUTION

1. A qualified technician should evaluate the Heat Pump.
2. Please contact the installing dealer for service.

5.2 Issues and Resolutions

Please perform the following troubleshooting.

For further assistance, please contact AquaCal. See "Contacting AquaCal AutoPilot, Inc.".

Blank Display**ISSUE**

The Heat Pump may have an incoming power problem.

RESOLUTION

Confirm electrical power is being supplied to the heat pump from electrical disconnect(s).

Circulation Pump Won't Activate

ISSUE

A circulation pump controlled by the heat pump will not activate as needed.

RESOLUTION

1. Confirm circulation pump is receiving power.
2. Reset circulation pump power breaker to allow internal pump faults to clear.
3. Confirm the circulation pump has been properly connected to the heat pump with installing dealer.
4. If the issue persists, please contact the installing dealer for service.

Heat Pump Not Running

ISSUE

The heat pump will not run.

RESOLUTION

1. Confirm equipment is receiving power. Is the heat pump display illuminated?
 - If not, confirm the main breaker (located at the power supply panel) and the disconnect switch (located near the heat pump) are both activated.
2. Confirm correct mode is selected.
 - See "*Set Efficiency Mode*" on page 32.
3. Confirm thermostat is set correctly.
 - When heating the water is desired, the thermostat should be set above the current water temperature.
 - When cooling the water is desired, the thermostat should be set below the current water temperature.
 - See "*Setting a desired water temperature setpoint*" on page 29.
4. If an error code is displayed, diagnose and correct the cause of the code.
 - See "*Fault Codes*" on page 57.
5. If an external controller is being used to control the heat pump, confirm the external device is correctly set to activate the heat pump. See documentation for external controller.
6. If the issue persists, please contact the installing dealer for service.

Heat Pump Won't Deactivate

ISSUE

The heat pump will not deactivate.

RESOLUTION

1. Confirm the correct mode has been set on the heat pump. See "*Activate HEAT Mode, COOL Mode, or AUTO Mode*" on page 30.
2. If deactivating the heat pump, confirm that the power LED is red and not green. See "*Control Panel*" on page 27.
3. Confirm the heat pump has reached the desired temperature set on the thermostat. The heat pump will continue to run until the set temperature is reached. See "*Setting a desired water temperature setpoint*" on page 29.
4. The heat pump will continue to run past it's set temperature by approximately two degrees Fahrenheit. This is normal.
5. Wait at least two minutes for the variable speed compressor to cycle down after reaching the set temperature.
6. If the heat pump is using an external controller, it may not be set correctly. See the external controller's manual.

Heat Pump Is Running, Not Heating

ISSUE

The heat pump is running. But the water is not heating.

RESOLUTION

1. If the heat pump is using an external controller, confirm it is set correctly.
 - If the heat pump is still not running correctly with this device, contact the installer of the device or the device's manufacturer for further assistance.
2. Confirm heat pump mode is set to heat.
3. Confirm thermostat is set higher than the current water temperature.
4. Confirm valves are positioned to heat the correct body of water (either the pool or the spa). If heating a spa that overflows into a pool, confirm the spa is isolated when being heated (not flowing into the pool).
5. Confirm heat pump is transferring heat into the water.
 - Measure the temperature of air discharge coming out of the heat pump fan. If discharge air is between 8° to 16° F (-13° to -9° C) colder than the outside ambient air, the heat pump is moving heat into the water.
6. If an error code is displayed, diagnose and correct cause of code.
 - See "*Fault Codes*" on page 57.
7. Confirm that the filter pump has a sufficient run-time. The heat pump will not run (or heat the water) without water flow.
8. If heating a spa, deactivate air blower or venturi (if equipped) to allow for quicker heating times. For pools, deactivate water features, such as slides, waterfalls, or fountains to allow water to retain heat. Use of a liquid pool blanket product, such as an Aqua Blanket™, can also compensate for excessive heat loss.
 - See "*Pool Blankets*" on page 48.
9. If the issue persists, please contact the installing dealer for service.

Heat Pump Is Running, Not Cooling

ISSUE

The heat pump is running. But the water is not cooling.

RESOLUTION

1. If the heat pump is using an external controller, confirm the heat pump is programmed properly to allow for cooling.
 - See "*Activate HEAT Mode, COOL Mode, or AUTO Mode*" on page 30.
2. Confirm the heat pump mode is set to cool.
3. Confirm the thermostat is set below the current water temperature.
4. Confirm valves are positioned to cool the correct body of water (either the pool or the spa). If cooling a spa that overflows into a pool, confirm the spa is isolated when being cooled (not flowing into the pool).
5. If an error code is displayed, determine and correct the condition causing the code.
 - See "*Fault Codes*" on page 57.
6. Confirm heat pump is transferring heat out of the water.
 - Measure the temperature of air discharge coming out of the heat pump's fan. If the air is between 8° to 16° F (-13° to -9° C) warmer than the outside ambient air, the heat pump is moving heat out of the water.
7. Confirm that the filter pump has a sufficient run-time. The heat pump will not run (or cool the water) without water flow.
 - See "*Cooling the water for the first time*" on page 48.

Ice Forming on the Heat Pump

ISSUE

When conditions are too cold for proper operation, the heat pump will enter a defrost mode. This prevents ice from building up on the evaporator coil.

RESOLUTION

- During freezing conditions, pool or spa heating will continue. Frost or ice may develop during the "countdown" to the active defrost (up to 30 minutes). This is normal.
- The heat pump will enter an "active defrost" stage to remove the accumulated frost and ice.
 - Be sure to observe the unit for at least 30 minutes. If it has not entered an active defrost cycle, call for service.

TIP:

The heat pump can be manually defrosted by temporarily switching to the cooling mode until the ice or frost melts.

- If the ambient air temperature is (or will be) falling below 32° F (0° C) for more than 8 hours, winterize equipment.
 - See "*Winterizing*" on page 50.

Unable to Connect Using Wi-Fi

ISSUE

Internal WiFi has been activated, but the heat pump is not connected to the user's home WiFi access point.

RESOLUTION

Confirm the heat pump is properly communicating with the user's home WiFi:

- Check that the user is using the correct password for the home's WiFi.
- Confirm user's home WiFi is in range, powered, and working with other devices in the home.
 - This can be done by checking the RSSI in application. If the RSSI is showing as "poor", the user may need to consider using a WiFi extender.

Confirm if the heat pump's WiFi setup process been completed:

- If the WiFi has been successfully setup in the past, the green WiFi LED on the back of the heat pump should be a solid green. If not, press and hold the WiFi setup button on the heat pump for 10 seconds to start the setup process. See "*Configure to use WiFi*".

Water Coming From Heat Pump

ISSUE

The water may be normal condensation produced as a by-product of the heat pump's refrigeration process.

The heat pump can produce up to 8 to 10 gallons (30 to 38 liters) of condensation per hour depending on the humidity of the ambient air. Determine if the water is condensation or a possible leak.

RESOLUTION

1. Deactivate heat pump, leaving the filter pump on. After several hours, determine if the water is still coming from the heat pump.
2. If using chlorine or bromine as a pool/spa sanitizer, test the water around the heat pump using a test strip. If the test strip indicates that chlorine or bromine is present, a leak may exist.

