

MODEL ANP50 ANP80 ANP100

Ultra Silent, High Performance, Attractive Design Grille

Description

- Very quiet fan for ceiling or wall mounted Hold and ETL evaluation and confirm to UL and cUL safety standards. HVI certified and ENERGY STAR.
- It comes with a capacitor start motor which is known for its high efficiency and long lasting reliability. It holds an ETL evaluation and conforms to UL and cUL safety standards.

Housing

- Made of rugged 26 GA galvanized steel
- Detachable 4 inch polymeric collar which includes a light weight built in back draft damper.
- Housing size: 9"x9"x5 3/4"

Motor/Blower

- Plug in permanently lubricated motor- Engineered for continuous operation.
- Power rating should be 120 volts and 60 Hz
- Motor comes with a built in overload disconnect for safety and longer motor life.

Grille

- The grille is low profile that has elegance and still able to maintain its simplicity.
- Grille dimension: 11-7/8"x11-3/8".

Typical specification

- Ceiling ventilator shall have corrosion resistance galvanized steel.
- It shall be ducted to a roof vent or wall cap using 4 inch round pipe.
- Blower assembly shall be removable, have a centrifugal type blower wheel and a permanently lubricated motor designed for continuous operation.
- Includes an attachable non metallic collar with build in back draft damper.
- Air and sound delivery shall meet, HVI certified ratings as per the fan curves attached.



Optional
Speed Control Kit
LED Light Kit
Ceiling Radiation Damper

Reference	QTY.	Remarks	Project:
			Location:
			Architect:
			Engineer:
			Contractor:
			Submitted by:
			Date:

CERTIFICATIONS



Model Number	ANP50	ANP80	ANP100
Static Pressure in inches w.g.	0.1	0.1	0.1
Air Volume (CFM)	50	80	100
Noise (sones)	0.4	0.6	0.8
Fan watts	16W	18W	23W
Duct Diameter	4"		
Power Rating (V/Hz)	120/60		

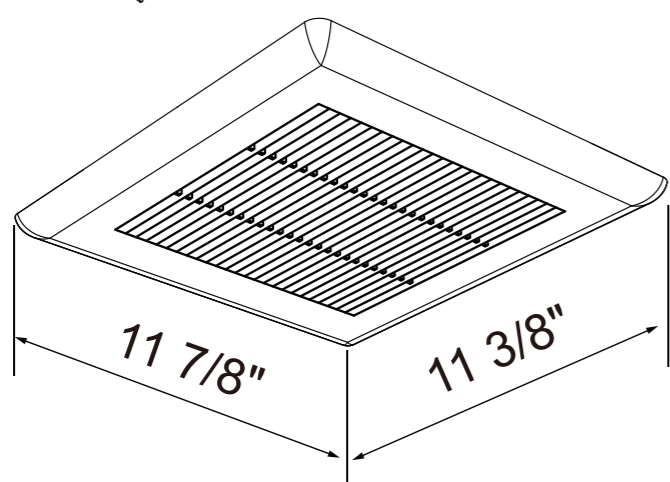
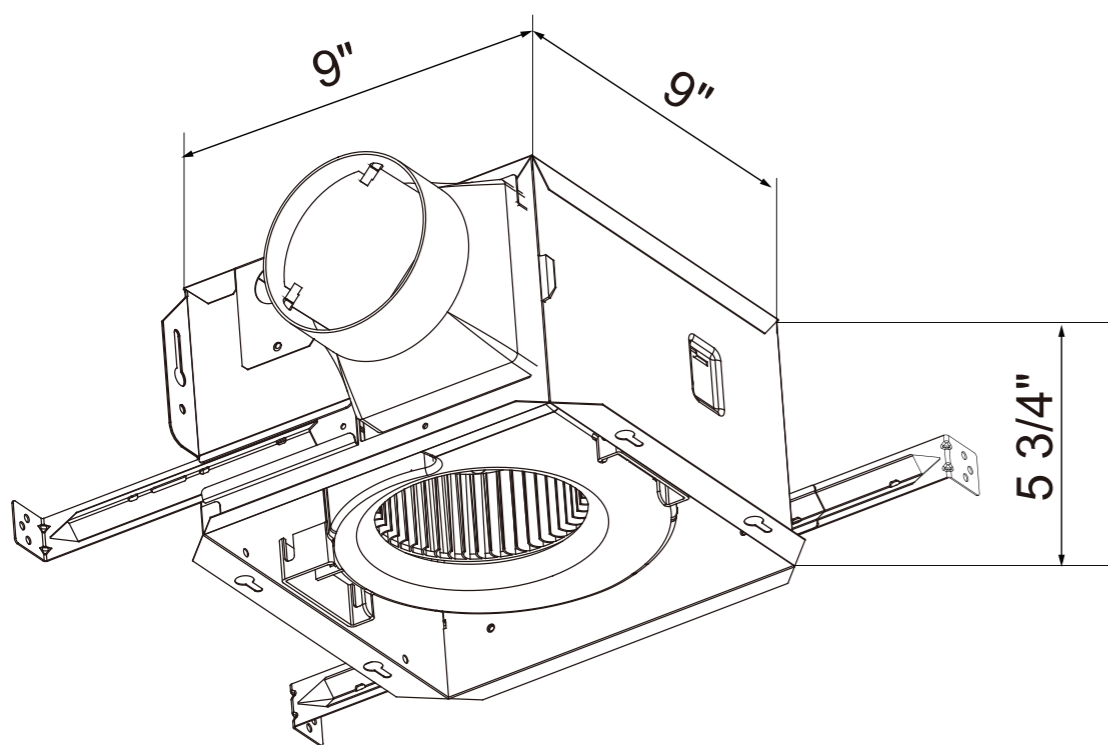

STANDARD GRILLE

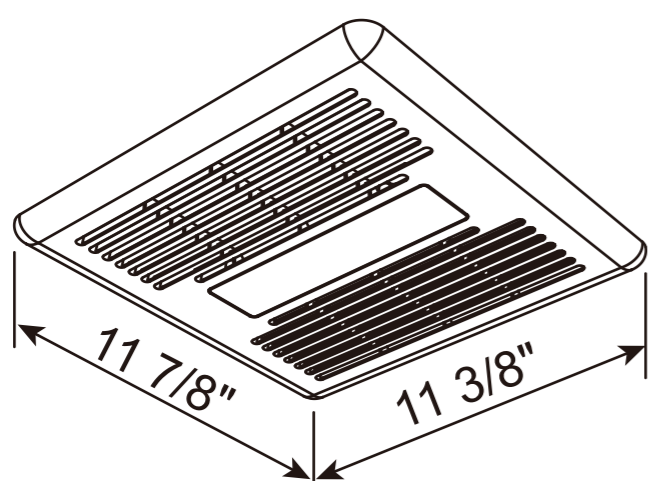

LED LIGHT GRILLE

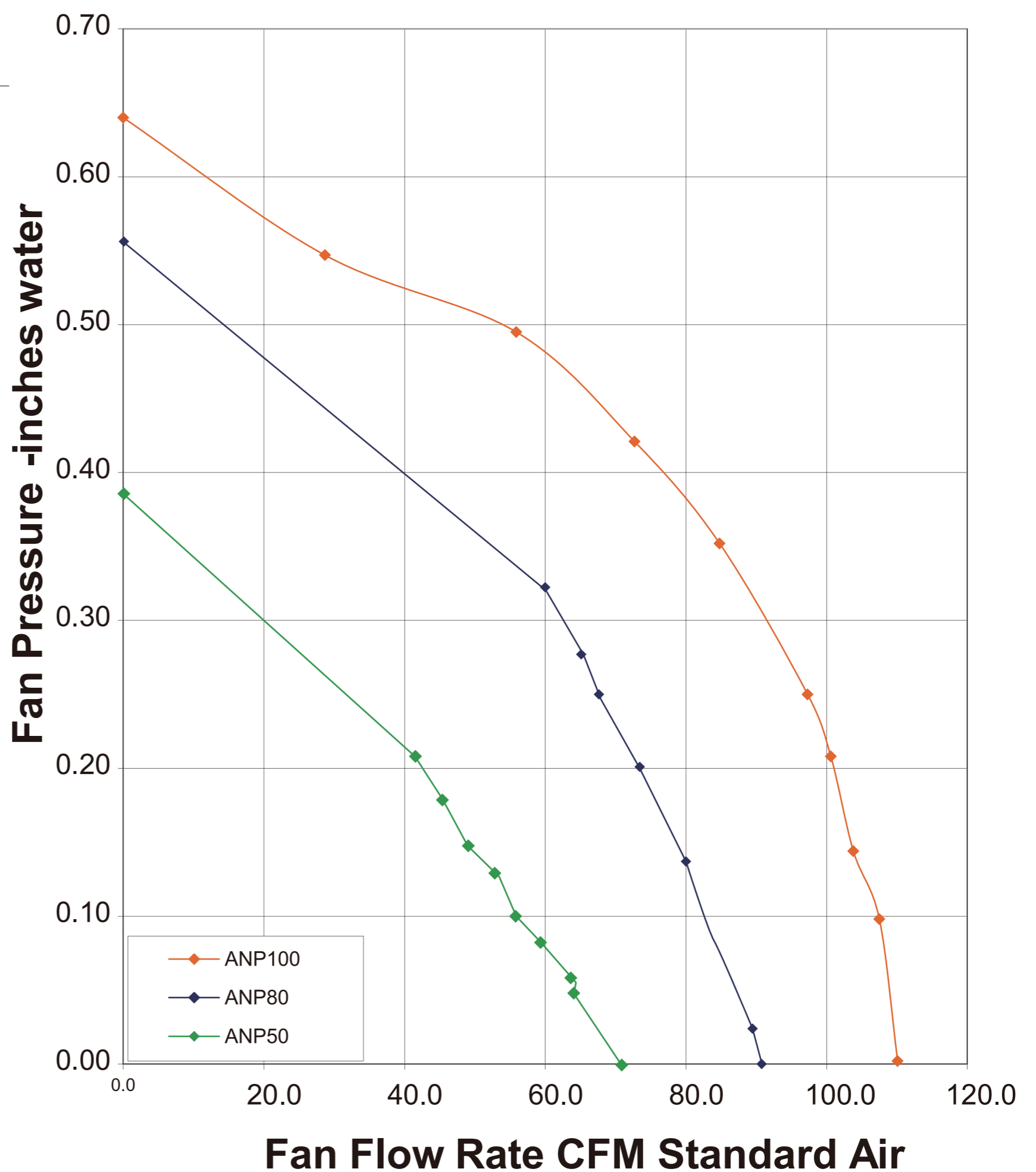

CERTIFICATIONS

