



DESCRIPTION

Energy Recovery Ventilators are the complete whole house ventilation system designed to bring a continuous supply of fresh air into the house while exhausting an equal amount of stale air.

CASING

Steel casing is covered with high-quality multilayer aluminium and zinc alloy to prevent corrosion. The casing is equipped with a safety switch to turn the ventilator off when the service panel is opened.

FILTER

Washable MERV 6 air filters in exhaust and supply air streams.
Optional supply: anti grease aluminum filter.

ENERGY RECOVERY CORE

Specially designed polymer enthalpic core provides energy recovery.

DEFROST SYSTEM

To protect the energy recovery core, the electronic freezing protection system is applied. It switches the supply fan off as the temperature sensor requires. Warm extract air defrosts the heat recovery core, then the supply fan switches on and the ventilator continues operating under rated conditions.

MOTORS

German made high-efficient motor combined with backward inclined impeller delivers exceptionally powerful airflow and high static pressure. Built-in thermal overheating protection with automatic restart makes the motor operation secure and reliable. Permanently lubricated ball bearings inside the motor provide long (40000 hours) trouble- and maintenance-free operation.

FANS

The ventilator is equipped with supply and exhaust centrifugal fans with backward inclined blades and built-in thermal overheating protection with automatic restart. The electric motors and the impellers are dynamically balanced in two planes.

CONTROL

The ventilator is equipped with 3-step switch on it's side panel to choose STANDBY, LOW or MEDIUM mode for continuous operation.

The unit can be equipped with wide range of additional controls to switch boost on demand.

WARRANTY

5 year warranty

DIMENSIONS

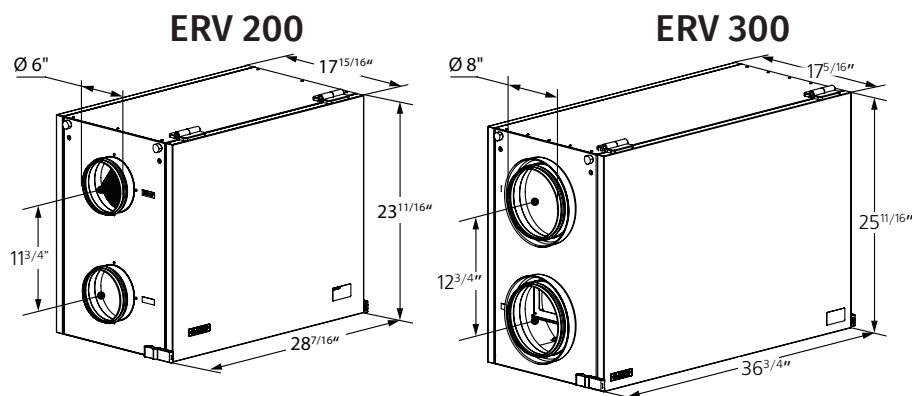

Tel: 888-640-0925
513-348-3853
Fax: 513-268-4597

Sales@ventsus.com
VentsUS.com
11013 Kenwood Road,
Cincinnati, Ohio 45242





BRIG ERV 200, 300

PRODUCT SPECIFICATIONS

TECHNICAL DATA

ENERGY RECOVERY VENTILATORS

PERFORMANCE

Model	Volts	Max. Amps	Net Supply Air Flow CFM (L/s)												Duct Dia.
			Ext. Static Pressure in. wg (Pa)												
			0,1" (25Pa)	0,2" (50Pa)	0,3" (75Pa)	0,4" (100Pa)	0,5" (125Pa)	0,6" (150Pa)	0,7" (175Pa)	0,8" (200Pa)	0,9" (225Pa)	1,0" (250Pa)	1,2" (275Pa)	1,4" (300Pa)	
ERV 200	120V, 60Hz	1.8	213 (101)	200 (94)	187 (88)	173 (82)	159 (75)	145 (68)	130 (61)	117 (55)	101 (48)	87 (41)	71 (34)	56 (26)	6"
ERV 300	120V, 60Hz	3.8	257 (121)	239 (113)	223 (105)	207 (98)	190 (90)	175 (83)	162 (76)	151 (71)	139 (66)	129 (61)	118 (56)	107 (50)	8"

Model	Mode	Temperature		Net Air Flow		Power Consumed	Sensible Recovery Efficiency
		°C	°F	(L/s)	(cfm)	(Watts)	SRE (%)
ERV 200	HEATING	0	32	30	64	208	79
		0	32	45	95	210	76
		0	32	60	127	212	73
ERV 300	HEATING	0	32	41	87	444	77
		0	32	66	141	446	73
		0	32	100	213	447	71

MODEL	QUANTITY	COMMENTS	PROJECT
			location:
			architect:
			engineer:
			contractor:
			submitted by:

Tel: 888-640-0925 Sales@ventsus.com
 513-348-3853 VentsUS.com
 Fax: 513-268-4597 11013 Kenwood Road,
 Cincinnati, Ohio 45242

