



Guardian Series™



[Download Instructions](#)

EMP Shield Guardian Series™ Single Phase and Three Phase Installation Instructions

WARNINGS & CAUTIONS:

- **TO BE INSTALLED BY A LICENSED ELECTRICIAN AND/OR USED IN ACCORDANCE WITH ELECTRICAL CODES AND LOCAL REGULATIONS. ELECTRICITY IS DANGEROUS WHEN NOT USED PROPERLY AND MAY CAUSE FIRE, SHOCK, OR DEATH.**
- INSTALLATION OF AN EMP SHIELD PROTECTION DEVICE IN A BRANCH CIRCUIT MUST BE DONE BY A QUALIFIED ELECTRICIAN.
- READ ALL INSTRUCTIONS BEFORE INSTALLING A DEVICE.
- EMP SHIELD DEVICES MUST BE INSTALLED ON A LINE THAT IS SERVED BY DISCONNECT MEANS, SUCH AS 20-AMP CIRCUIT BREAKERS OR 20-AMP FUSED DISCONNECT SWITCHES. • EMP SHIELD DEVICES PERFORM IN ACCORDANCE TO THEIR SPECIFICATIONS AND MAY NOT SURVIVE SUSTAINED OVERVOLTAGES.
- INSTALL AND USE A DEVICE ONLY WITH STANDARD COPPER OR COPPER CLAD WIRES.

FEATURES:

- UL 1449 - Type 2 SURGE SUPPRESSION – Compliant
- UL 1448 Ed #4 / CSA C22.2#269.2 Ed #2 - Compliant
- (MIL-STD-188-125-1) HIGH-ALTITUDE ELECTROMAGNETIC PULSE PROTECTION – Certified • IEEE C62.41-1991 category A&B combination wave suppression
- Solid-state semiconductor circuitry for each phase • Each phase independently fused
- Green and Red color LED diagnostic indicators for each phase
- Audible alarm indicator
- NEMA 4 plastic enclosure
- 1 conduit entrance port

DESCRIPTION:

Guardian Series by EMP Shield Inc. is designed to protect critical equipment and infrastructure, for which interruption of power or signal must be kept to a minimum, and for which Operations must be aware of the problem or interruption. Our technology provides protection against high altitude electromagnetic pulse (HEMP), coronal mass ejection (CME), lightning, and power surges. Guardian Series is our fastest acting and most robust surge protection technology. Our Guardian Series products have a 200KA Short Circuit rating, and are IP-68 rated (allowing for continued operations at 15 meters under water).

Each device provides advanced Alarm and Indication. The Series includes models for use on 120/240V, single-phase, 120/208V, 3-phase, 277/480V, and 3-phase. The standard J-Box UL certified enclosure with integrated conduit port simplifies mounting in typical frame construction environments, and provides convenient connection means to existing branch panels.

DEVICE INSTALLATION:

System Voltage Requirements

1. Verify the operational system voltage. Measure panel voltage, line to neutral (L-N) and verify proper electrical grounding. System voltage must not exceed the rated continuous RMS voltage specified on the EMP Shield device label.

Location and Mounting

1. Locate the EMP Shield device as close as possible to the branch circuit breaker panel. Connection lead length between the EMP Shield device and circuit breaker box should be minimal for best protection. The location should also permit good visibility of the EMP Shield device's diagnostic lights.

2. Remove the circuit breaker panel cover and determine the breaker-panel wiring entry point relative to chosen location of the EMP Shield device.

NOTE: Unit installation should allow at least one inch of clearance from the edge of the circuit breaker panel cover.

3. For surface-mount circuit breaker panels, the EMP Shield device may be connected using rigid conduit to any conduit port.

4. For non-surface mount installations (flush mounted breaker box), secure the EMP Shield inside the breaker box and connect the LED box on the exterior of the breaker box.

Wiring Connections

The EMP Shield comes with a terminal block XHHW 10 AWG Stranded Copper wire. Tighten to Torque 25 in-lbs.

1. **Turn off power at the main circuit breaker or fuse.**

WARNING: TO AVOID FIRE, SHOCK OR DEATH, TURN OFF POWER AT CIRCUIT BREAKER OR FUSE AND TEST THAT POWER IS OFF BEFORE WIRING!

CAUTION: The green ground wire must be connected to ground lug. Failure to do so may result in fire or shock. See Fig. 1- 4 for installation diagrams.

2. If conduit is being used, thread the EMP Shield device's wire leads through the conduit to circuit breaker interior.

3. Select circuit breakers as close as possible to each service entrance lug. Twenty-Amp (20A) circuit breakers are recommended, and may share EMP Shield device and branch circuit leads. The breakers provide additional failure protection as well as an EMP Shield connection and servicing disconnect.

WARNING: Do not connect EMP Shield leads directly to the electrical service entrance lugs. This may result in fire, shock or death.

6. Connect the Leads for Single Phase and Three Phase (see instructions below):

Single Phase: Lead lengths should be as short as possible. Connect the BLACK (L1), and RED (L2) leads to each PHASE lines through the selected circuit breakers. Connect the WHITE lead to NEUTRAL as close as possible to NEUTRAL entrance service lug.

Three Phase: Lead lengths should be as short as possible. Connect the BROWN (L1), ORANGE (L2), and YELLOW (L3) leads to each PHASE lines through the selected circuit breakers. Connect the GRAY lead to NEUTRAL as close as possible to NEUTRAL entrance service lug (colors specified are for typical 277/480 volt units).

NOTE: Avoid long loops and do not coil extra lead wire.

7. Replace the circuit breaker panel cover. Installation is complete.

Power ON

1. Restore power to circuit breaker panel. The green diagnostic lights on the EMP Shield should turn ON. These LED lights indicate that the EMP Shield is installed and is monitoring your incoming power source.

2. If during normal operation a diagnostic light shuts off, have an electrician determine if phase power is applied. If power is present, the unit should be replaced and/or upgraded as soon as possible.

Installation Note: Suitable for use on a circuit capable of delivering no more than 10,000 rms symmetrical amperes, 120V maximum when protected by a 20 ampere circuit breaker rated 120 volts minimum. The interrupting rating of the fuse or breaker shall not be less than the available fault current.



Download Instructions

See Next Pages for Installation and Wiring Diagrams

Installation and Wiring Diagrams

Figure 1 - Single Phase Installation

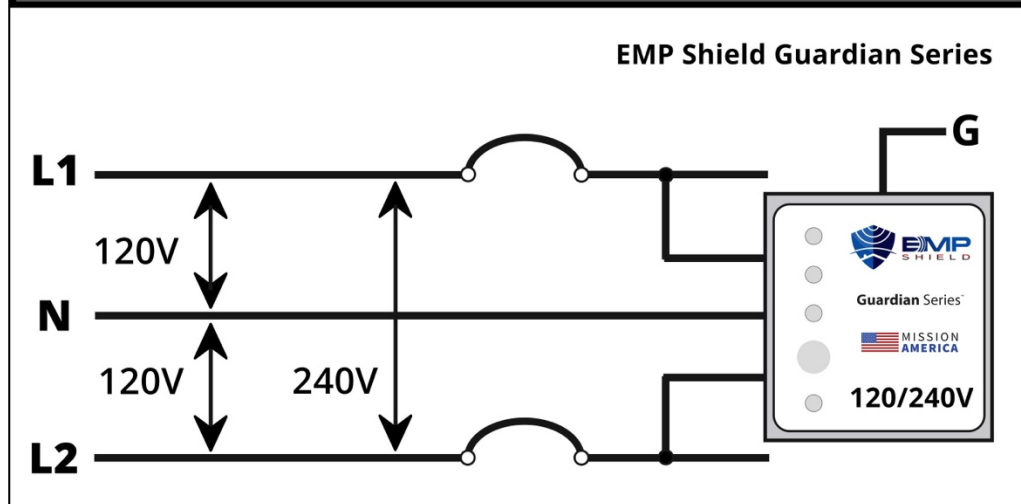

Figure 2 - Single Phase Wiring

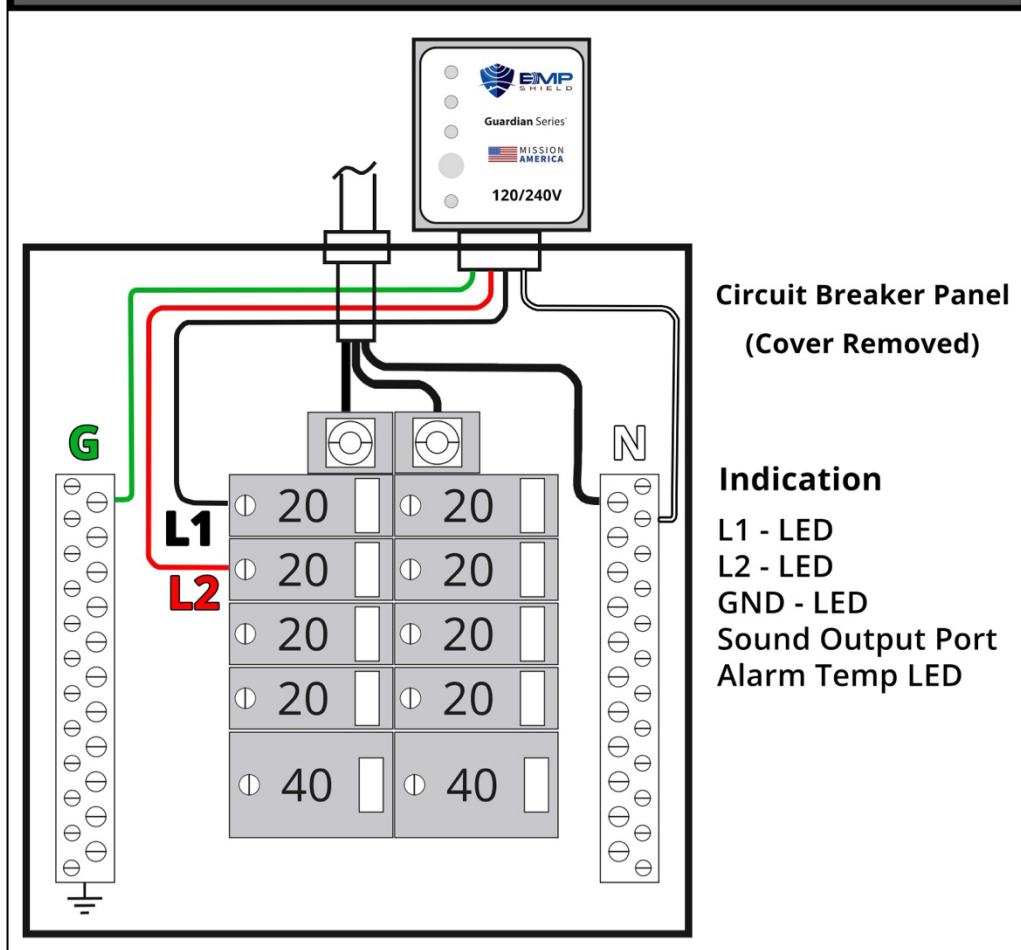

Figure 3 - Three Phase Installation

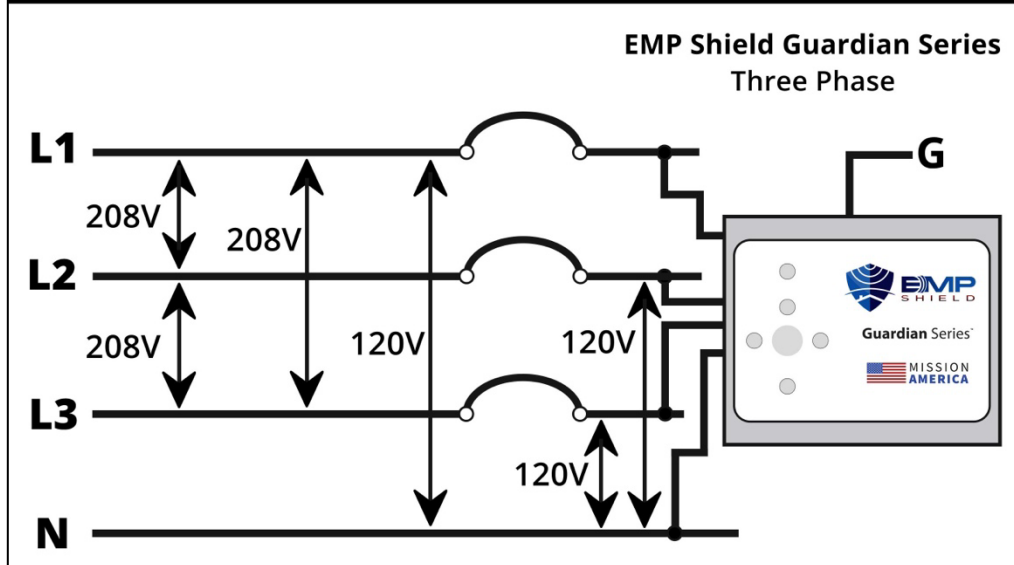

Figure 4 - Three Phase Wiring

