

# EMP Shield Installation Instructions

120/240V, 120/208V, 277/480V, 240V European Model

## WARNINGS & CAUTIONS:

- TO BE INSTALLED BY A LICENSED ELECTRICIAN AND USED IN ACCORDANCE WITH ELECTRICAL CODES AND REGULATIONS.
- INSTALLATION OF AN **EMP Shield** MUST BE CONDUCTED BY A QUALIFIED ELECTRICIAN.
- READ ALL INSTRUCTIONS BEFORE INSTALLING.
- **EMP Shield** DEVICES MUST BE INSTALLED ON A LINE THAT IS SERVED BY DISCONNECT MEANS, SUCH AS 20-AMP CIRCUIT BREAKERS OR 20-AMP FUSED DISCONNECT SWITCHES.
- **EMP Shield** MAY NOT SURVIVE SUSTAINED OVERVOLTAGES.
- USE THIS DEVICE ONLY WITH COPPER OR COPPER CLAD WIRE.

## FEATURES:

- UL 1449 - Type 2 SURGE SUPPRESSION – Compliant
- **(MIL-STD-188-125-1) HIGH-ALTITUDE ELECTROMAGNETIC PULSE PROTECTION – Certified**
- IEEE C62.41-1991 category A&B combination wave suppression
- Solid-state semiconductor circuitry for each phase
- Each phase independently fused
- Green LED diagnostic indicator for each phase
- NEMA 4 plastic enclosure
- 1 conduit entrance port

## DESCRIPTION:

**EMP Shield** (120/240V, single-phase version), (240V, EU Version), (120/208V, 3-phase version) or (277/480V, 3-phase version) Branch Panel Mounted devices have been designed to protect residential, small commercial, and industrial establishments from high voltage transients. The standard J-Box plastic enclosure with integrated conduit port simplifies mounting in typical frame construction environments, and provides convenient connection means to existing branch panels.

## TO INSTALL:

### System Voltage Requirements

1. Measure panel voltage, L-N, to determine the system voltage. System voltage must not exceed the specified maximum continuous RMS voltage on the **EMP Shield** device label.

### Location and Mounting

1. Locate the **EMP Shield** device as close as possible to the branch circuit breaker panel. Connection lead length between the **EMP Shield** device and circuit breaker box should be minimal for best protection. The location should also permit good visibility of the **EMP Shield** device's diagnostic lights.
2. Remove the circuit breaker panel cover and determine the breaker-panel wiring entry point relative to chosen location of the **EMP Shield** device.  
**NOTE:** Since the circuit breaker panel and the **EMP Shield** unit have overlapping covers, installation should allow at least one inch of clearance from the edge of the circuit breaker panel cover.
3. For surface-mount circuit breaker panels, the **EMP Shield** device may be connected using rigid conduit to any conduit port.
4. For non-surface mount installations, secure the **EMP Shield** inside the breaker box and connect the LED box on the exterior of the breaker box.

### Wiring Connections

The **EMP Shield** (RL – Version) comes with a terminal block including 10 AWG COPPER WIRE. Tighten to Torque 25 in-lbs.  
The **EMP Shield** (W – version) comes with preconnected 10 AWG COPPER WIRE. Tighten to Torque 25 in-lbs.

1. **WARNING:** TO AVOID FIRE, SHOCK OR DEATH, **TURN OFF POWER AT CIRCUIT BREAKER OR FUSE AND TEST THAT POWER IS OFF BEFORE WIRING!**
2. Connect wire leads to terminal block: BLACK, RED, BLUE to PHASES, WHITE to NEUTRAL and GREEN to GROUND. See **Figures 1 through 4, 7** on reverse side.
- CAUTION:** If plastic conduit is used, Green ground wire must be connected to ground lug, and Green wire inside enclosure must also be connected to ground lug. Failure to do so may result in fire or shock. See **Fig. 1, Fig. 2, Fig. 3, Fig. 4, Fig. 5, Fig. 6, and Fig. 7.** on reverse side for installation diagrams.
3. Thread the **EMP Shield** device's wire leads through the conduit to circuit breaker interior.
4. Secure the **EMP Shield** cover with the screws removed previously.
5. Select circuit breakers as close as possible to each service entrance lug. Twenty-Amp (20A) circuit breakers are recommended. The breakers provide additional failure protection as well as an **EMP Shield** connection and servicing disconnect.  
**NOTE:** Do not connect **EMP Shield** leads directly to service entrance lugs. This may result in fire, shock or death.
6. Lead lengths should be as short as possible. Connect the BLACK, RED, BLUE leads to each PHASE through the selected circuit breakers. Connect the WHITE lead to NEUTRAL as close as possible to NEUTRAL entrance service lug.  
**NOTE:** Avoid long loops and do not coil extra lead wire.
7. Replace the circuit breaker panel cover. Installation is complete.

### Power ON

1. Restore power to circuit breaker panel. The green diagnostic lights on the **EMP Shield** should turn ON. These LED lights indicate that the **EMP Shield** is installed and is monitoring your incoming power source (1 LED for DC versions, 2 LEDs for single phase power, and 3 LEDs for three phase power).
2. If during normal operation a diagnostic light shuts off, have an electrician determine if phase power is applied. If power is present, the unit should be replaced and/or upgraded as soon as possible.

Figure 1 – Single Phase Installation

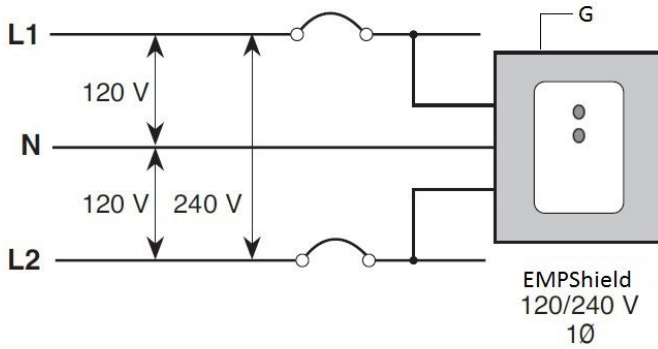

Suitable for use on a circuit capable of delivering no more than 10,000 rms symmetrical amperes, 120 volts maximum when protected by a 20 ampere circuit breaker rated 120 volts minimum. The interrupting rating of the fuse or circuit breaker shall not be less than the available fault current.

Figure 3 – Three Phase Installation

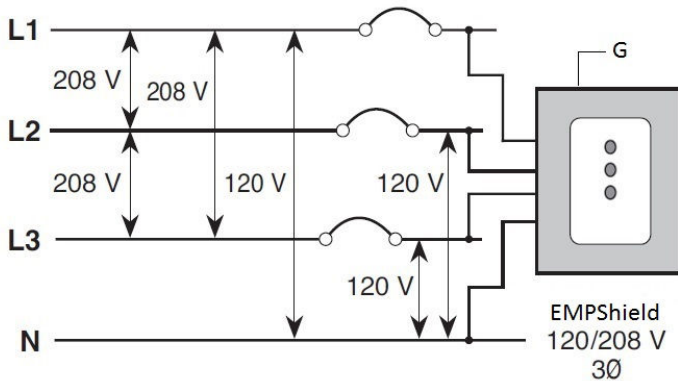

Suitable for use on a circuit capable of delivering no more than 10,000 rms symmetrical amperes, 120 volts maximum when protected by a 20 ampere circuit breaker rated 120 volts minimum. The interrupting rating of the fuse or circuit breaker shall not be less than the available fault current.

Figure 5 – 240V European Model Installation

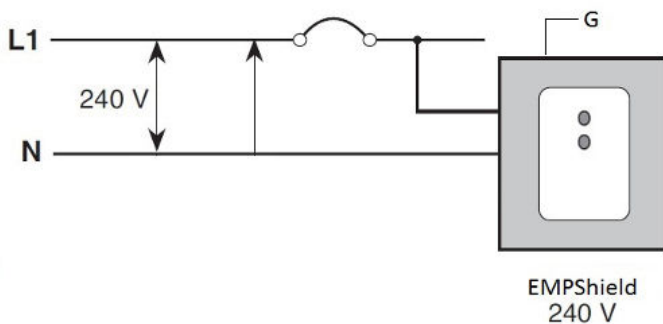

Suitable for use on a circuit capable of delivering no more than 10,000 rms symmetrical amperes, 240 volts maximum when protected by a 20 ampere circuit breaker rated 240 volts minimum. The interrupting rating of the fuse or circuit breaker shall not be less than the available fault current.

Figure 2 – Single Phase Wiring

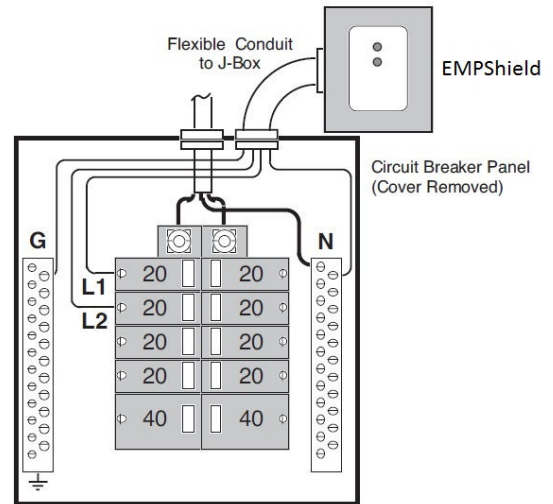

Figure 4 – Three Phase Wiring

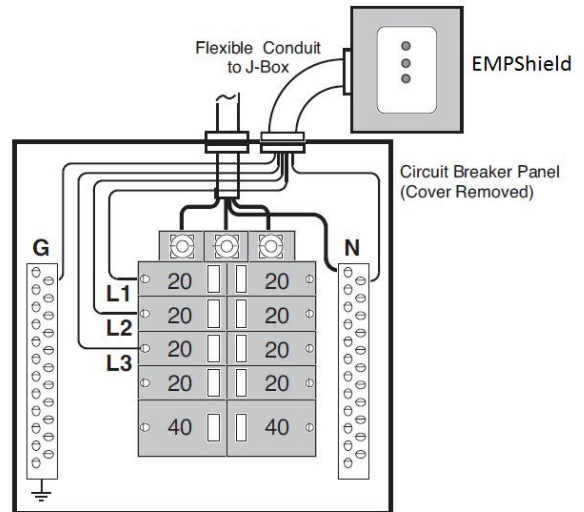

Figure 6 – 240V European Model Wiring

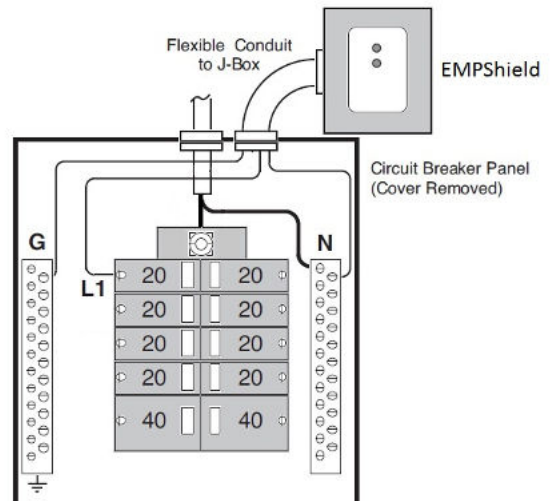
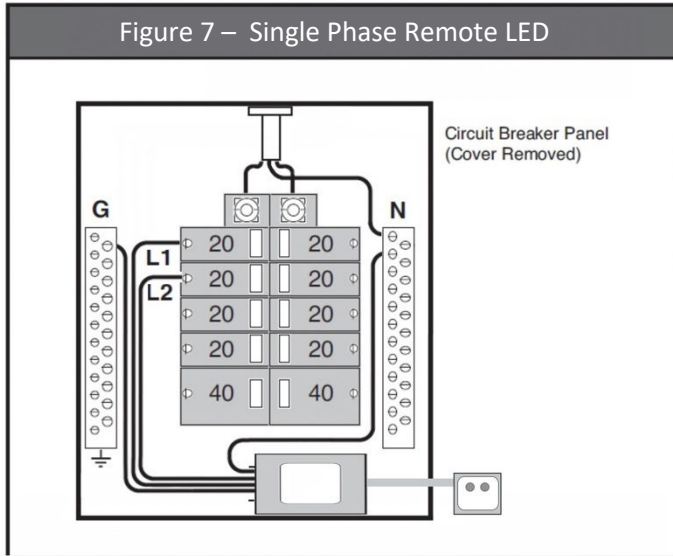

Figure 7 – Single Phase Remote LED



### LIMITED LIFETIME WARRANTY AND EXCLUSIONS

EMP Shield warrants to the original consumer purchaser and not for the benefit of anyone else that this product at the time of its sale by EMP Shield is free of defects in materials and workmanship under normal and proper use during the lifetime of the product. EMP Shield's only obligation is to correct such defects by repair or replacement, at its option, if the product is returned prepaid, with proof of purchase date, and a description of the problem to **EMP Shield, Inc. Att: Quality Assurance Department, 3908 S. 4<sup>th</sup> Street, Burlington, KS. 66839.**

This warranty excludes and there is disclaimed liability for labor for removal of this product or reinstallation. This warranty is void if this product is installed improperly or in an improper environment, overloaded, misused, opened, abused, or altered in any manner, or is not used under normal operating conditions or not in accordance with any labels or instructions. There are no other or implied warranties of any kind, including merchantability and fitness for a particular purpose. EMP Shield is not liable for incidental, indirect, special, or consequential damages, including without limitation, damage to, or loss of use of, any equipment, lost sales or profits or delay or failure to perform this warranty obligation. The remedies provided herein are the exclusive remedies under this warranty, whether based on contract, tort or otherwise.

**EMP Shield, Inc.**  
3908 S. 4<sup>th</sup> Street  
Burlington, Kansas 66839  
Phone: (620) 412-9978 / EMPShield.com