

EP CUBE 2.0

HOME ENERGY STORAGE SYSTEM

USER MANUAL



CONTENTS

- MANUAL DESCRIPTION**
 - About This Manual ----- 1
 - General Description ----- 1
 - Abbreviated Terms ----- 1

- SAFETY INSTRUCTIONS**
 - General Notice ----- 2
 - Emergency Procedures ----- 3

- PRODUCT INSTRUCTIONS**
 - EP Cube Description ----- 5
 - Typical System Topology ----- 7
 - EP Cube Compatibility ----- 11

- INSTRUCTIONS FOR USE AND CARE**
 - Use EP Cube ----- 13
 - General Operation And Care ----- 16
 - Product Update ----- 17
 - Internet Connection ----- 17
 - Disposal Instruction ----- 17
 - Warranty ----- 17

MANUAL DESCRIPTION

Thank you very much for choosing the EP Cube product series. We sincerely believe that EP Cube will optimize your home energy, and also look forward to your feedback on the performance of the product for improvement and better service.

About This Manual

This manual contains the product information, instructions for use and care, safety instructions, service and storage instructions, etc..

General Description

- EP Cube can only be used under conditions provided in the manual and any applicable local standards, laws and regulations. Any other use may cause personal injury and property damage.
- The illustrations and images provided in this manual are for demonstration purposes only. Actual product details may vary slightly in appearance on the installation site. Eternalplanet Energy Co., Ltd ("EP") has the right to final interpretation for all the related details of the product.
- The product shall be used in a situation conforming to the design specifications. Otherwise, it may cause product failure, resulting in abnormal product function or component damage. Personal safety accidents and property loss are not within the scope of product quality assurance.
- This manual and other product-related documents are an integral part of the product and need to be properly kept for the on-site installation personnel and relevant technical personnel to review it further.

Abbreviated Terms

- AC Alternating Current
- EV Electric Vehicle
- PV Photovoltaic

SAFETY INSTRUCTIONS

SAVE THESE INSTRUCTIONS – This manual contains important instructions for following Models:

Smart Gateway: SGNA2-200G1 and SGNA2-200G2;

Hybrid Inverter: HNA2-S11G1, HNA2-S11G2, HNA2-S11G3, HNA2-S11G4, HNA2-S11G5;

These instruction must be followed during installation and maintenance of the EP Cube system.

For personal protection and safety, please read this part carefully and strictly comply with its contents, during entire installation and use of the product. EP is not liable for

General Notice

This part contains the following symbols with important information for safety use.

 **WARNING:** Hot surface! To reduce the risk of burns. Do not touch!

 **DANGER:** Indicates a situation which if not avoided, can lead to death or serious injury.

 **CAUTION:** Indicates a situation in which attention is necessary to avoid potential injury or property damage.

DANGER

- Do not stack the unpacked products to avoid the irreversible damage.
- It is prohibited to touch the internal components of EP Cube when it's running. Ensure that the power switch and the breaker of EP Cube are always off prior to all installation, replacement, and maintenance processes.
- Do not attempt to open, disassemble, tamper with, or modify EP Cube.
- Do not squeeze, impact or puncture the battery, to avoid unnecessary damage and loss.
- Do not operate EP Cube outside of the specified conditions and requirements, or stand, lean on, or sit on the product.
- Do not place the EP Cube or its components in water or other liquids or expose EP Cube to flammable gases or other corrosive substances.

SAFETY INSTRUCTIONS

CAUTION

- The transportation, installation, and commissioning of the EP Cube must be carried out under the specified conditions. Do not expose EP Cube outside these specified conditions.
- EP Cube can only be installed, repaired, replaced, and maintained by licensed authorized personnel for safety and warranty purposes. Personnel must wear protective equipment during any operations.
- Do not place foreign objects on top of the product or insert them anywhere in the product. Make sure there is enough space on top of EP Cube for ventilation.
- Do not stack battery modules more than the specified quantity or reverse the polarity of the battery.
- Be careful to protect EP Cube from impact when installing EP Cube in a garage or near vehicles.
Operating or placing in high temperatures, and near heating equipment or sources of extreme heat will cause the battery modules to be thermally unstable, thereby exceeding the thermal runaway point of its material and potentially causing a fire.

Emergency Procedures

If any fault is found that may cause personal injury or product damage, the operation shall be terminated immediately, and effective protective measures shall be taken.

1. Notify all people who might be affected and ensure that they are able to evacuate the area.
2. Immediately contact the fire department or other relevant emergency response team.

SAFETY INSTRUCTIONS

In case of a fire

- Turn off Grid Circuit Breaker.
- Turn off EP Cube. (Refer to Page 14)
- Acceptable fire extinguisher types are carbon dioxide-based fire extinguishers, standard ABC fire extinguishers, and dry chemical fire extinguishers.

In case of flooding

- Stay out of the water if any part of the Battery Module, Hybrid Inverter, or wiring is submerged.
- Turn off EP Cube. (Refer to Page 14)
- If possible, protect the system by finding and stopping the source of the water and pumping water away.
- If the EP Cube service team has confirmed that it is safe to re-energize, let the area dry completely before use.

In case of an unusual smell or smoke from EP Cube

- Turn off the Grid Circuit Breaker.
- Turn off the PV connections.
- Turn off EP Cube. (Refer to Page 14).
- Clear the area around the Smart Gateway.
- Ventilate the room.

In case of EP Cube Smart Gateway making unusual noises

- Turn off the Grid Circuit Breaker.
- Turn off the PV connection.
- Turn off EP Cube. (Refer to Page 14).
- Ensure that ventilation fan area is clear.

PRODUCT INSTRUCTIONS

EP Cube Description

The EP Cube system consists of two standard components: the Hybrid and Smart Gateway. Hybrid is an integrated battery storage product which includes both Battery Modules and Hybrid Inverter.

A. Smart Gateway (subject to actual product)

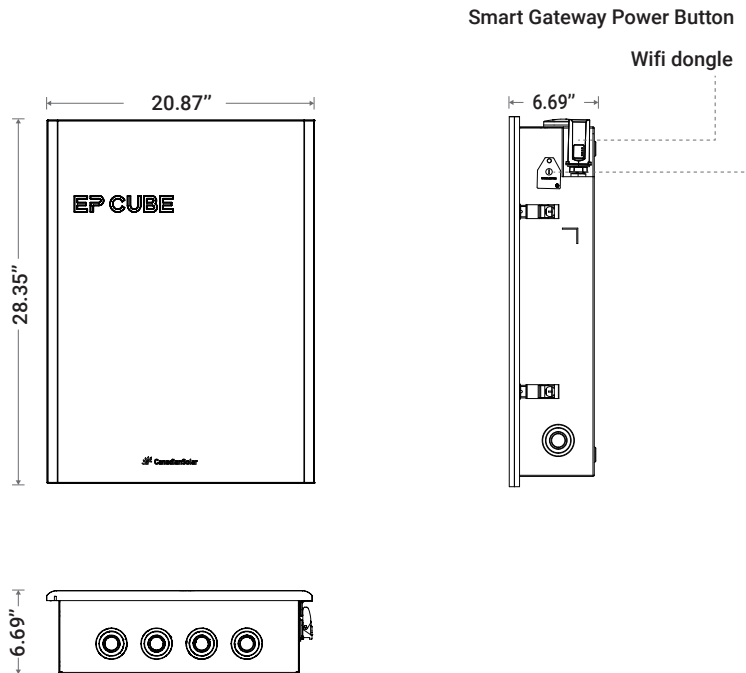

PRODUCT INSTRUCTIONS

B. Hybrid (subject to actual product)

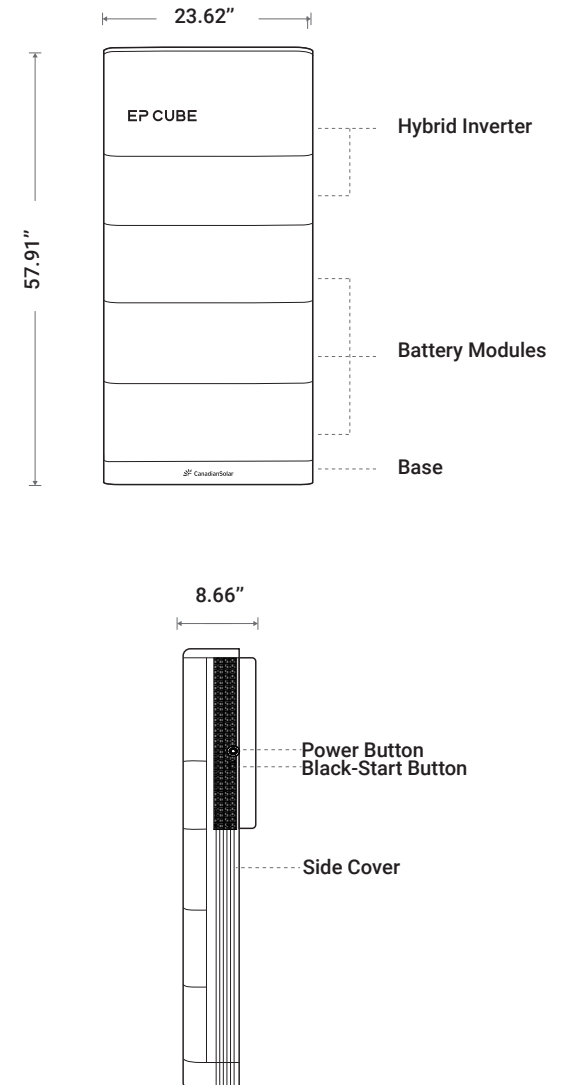

PRODUCT INSTRUCTIONS

Typical System Topology

EP Cube Smart Gateway supports 2 types of system topology, Whole home backup and partial home backup.

A. Whole Home Backup

In whole home backup system topology, EP Cube acts as power system stewards to fully manage and optimize the owner's entire home power supply according to the owner's setup/setting. All home appliances can be powered by EP Cube when a grid power outage occurs in the whole home backup topology.

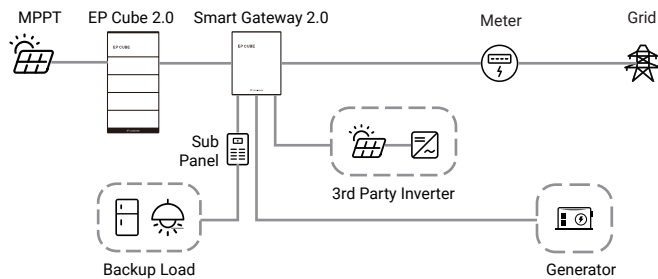

B. Partial Home Backup

In partial home backup system topology EP Cube acts as an auxiliary stewards of the power system to manage and optimize the power supply for part of the owner's home loads. Only the backup loads will be powered when a grid power outage occurs in partial-home backup topology.

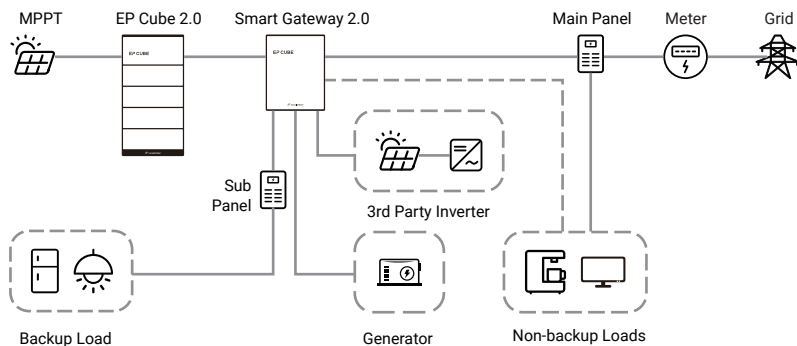

PRODUCT INSTRUCTIONS

Operation Mode

EP Cube has three different operation modes: Self-Consumption, Backup and Time Of Use. The owner can select a desired operation mode for daily use according to the description shown in the chart below.

Operation Modes	Descriptions
Self-Consumption	Store surplus solar energy in the battery modules, and manage it to discharge to support load when solar power is not enough.
Backup	Owner can select the backup mode on app to force charge battery modules as home backup energy.
Time Of Use	Owner can set peak time, super peak time, off-peak time and super off-peak time on app based on local utility Time Of Use billing mechanism, to save on electric bill.

Get to Know Different Operation Modes

A. Self-Consumption

During self-consumption mode power generated by PV is utilized to supply power to connected loads as a priority. Any surplus power is then used to charge the battery modules. Only once battery modules are fully charged, power is exported to grid. In an instance when power generation by PV is lesser than load consumption, battery modules discharge to support loads. Once the battery modules SOC reaches set value for reserve SOC, then loads are supported by grid power.

PV Power Usage Priority: Load > Battery > Grid.

Load Energy Source Priority: Photovoltaic > Battery > Grid

Battery Charging Source: PV only

PRODUCT INSTRUCTIONS

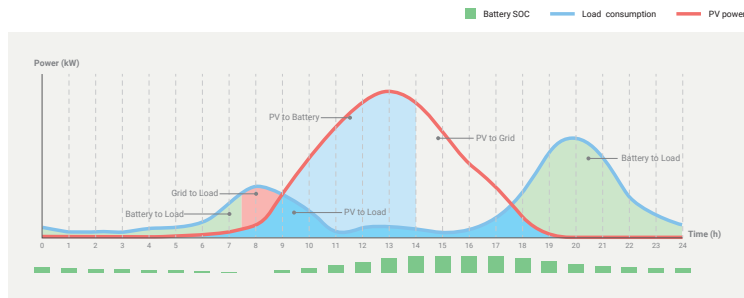

B. Backup Mode

During backup mode power, EP CUBE is charged at the rated power to the SOC value set by the user, and then batteries are in standby. Batteries are charged from PV power, and if excess PV power is not enough than grid power is used for charging. When the battery is fully charged, if the SOC value set by the user is not 100%, the SOC difference still be used to support load. When a power failure or grid outage occurs, EP CUBE seamlessly switch to provide backup power to household load.

PV Power Usage Priority: Load > Battery > Grid.

Load Energy Source Priority: Photovoltaic > Battery > Grid

Battery Charging Source: PV > Grid

C. Time-of-Use (TOU):

During TOU mode user can set off-peak and peak hours. 9 time-slots can be set for each category.

During off peak hours/During super off peak hours,

EP CUBE allows low price electricity from the grid to charge the battery to 100% SOC.

Battery Charging Source: PV > Grid

Load Energy Source Priority: Photovoltaic > Grid

PRODUCT INSTRUCTIONS

During peak hours, EP CUBE supports the load's power consumption from PV power and battery to avoid use of high price electricity from grid. Loads are supported by PV, and battery as priority power sources and excess consumption is supported by grid. During peak hours, system operation is consistent with "Self Consumption" mode. The system will take power from grid if the SOC is below the reserve SOC.

PV Power Usage Priority: Load > Battery > Grid.

Load Energy Source Priority: Photovoltaic > Battery > Grid.

Battery Charging Source: PV > Grid.

During super peak hours, EP CUBE supports the Users set super peak periods during which no power is will drawn from the grid, even if the EP CUBE is below to its reserved SOC. During this period, the battery will continue to discharge to provide power to the load until the SOC reaches 5%.

PV Power Usage Priority: Load > Battery > Grid.

Load Energy Source Priority: Photovoltaic > Battery > Grid.

Battery Charging Source: PV only.

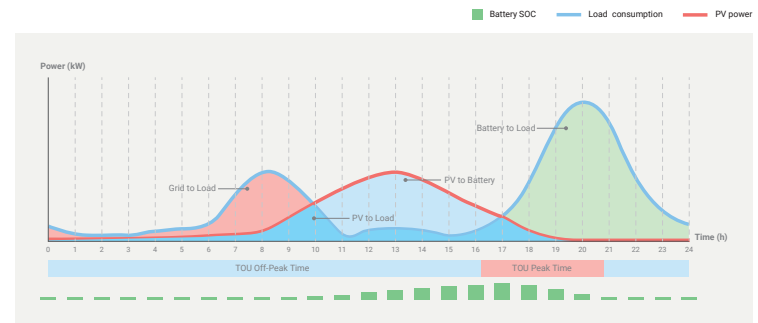

PRODUCT INSTRUCTIONS

EP Cube Compatibility

EP Cube design is modular and supports flexible expansion. Up to 3 units hybrid can be connected in parallel to support power demand. The diagram below indicates that the extend ports in Smart Gateway are used.

Option 1: No devices are connected to extend ports.

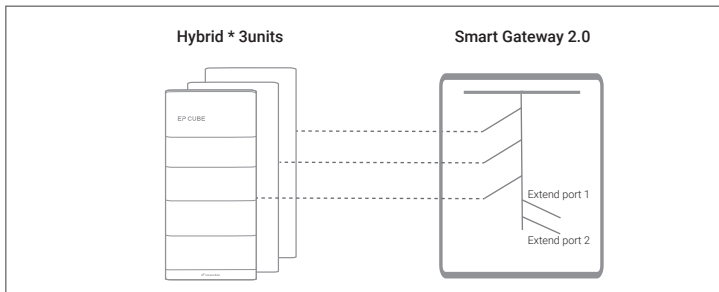

Option 2: Generator, or Solar Inverter, or EV Charger connect to extend port 1.

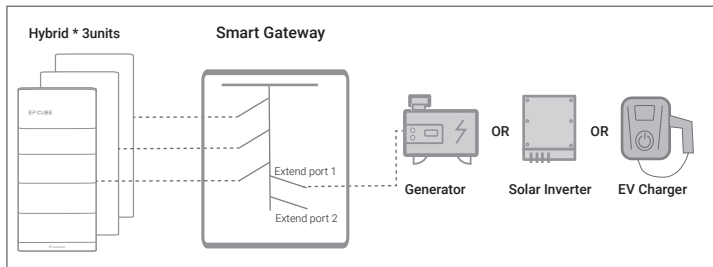

Option 3: Generator, Solar Inverter, or EV Charger connect to extend port 1. Solar Inverter or EV Charger connect to extend port 2.

PRODUCT INSTRUCTIONS

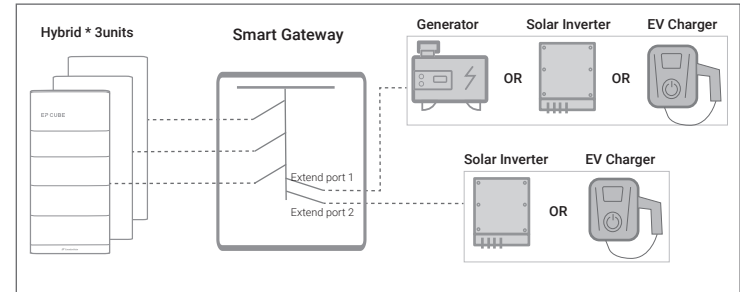

Note: Hardware integration is completed. Software is being updated, once completed this feature will be available.

If a product owner wants to extend the EP Cube system, please contact EP Cube authorized partner or Customer Service Center for support.

INSTRUCTIONS FOR USE AND CARE

Use EP Cube

A. EP Cube App

The owner will be able to monitor power flow and system performance via the app. Download the App for iOS and Android from app store.

B. Turn On EP Cube

On the condition that EP Cube is already energized. (Refer to item D).

1. Turn on the Hybrid by pressing down the power button on the right side.
2. Turn on the Smart Gateway by pressing down the button on the right.

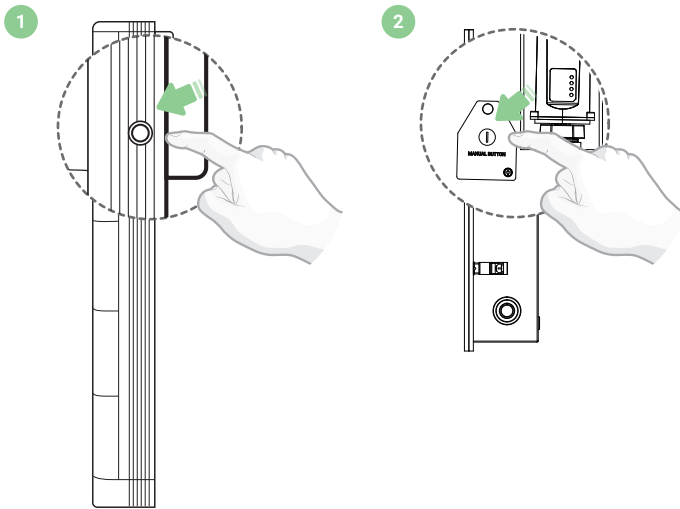

INSTRUCTIONS FOR USE AND CARE

LED Indicators: EP Cube has two operational states shown in the below table.

Status	LED Indication	Description
Stand by Mode	Bright & Solid	Running
Off	Off	Powered Off

C. Turn Off EP Cube

1. Turn off the Smart Gateway by pressing down the button on the right.
2. Turn off the Hybrid by pressing down the power button on the right side.

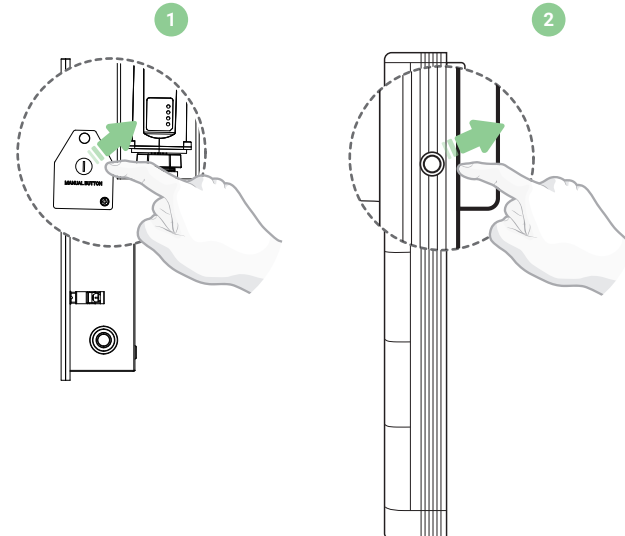

INSTRUCTIONS FOR USE AND CARE

D. Energize EP Cube System

1. Turn on Grid Circuit Breaker.
2. Turn on PV Switches.
3. Turn on Hybrid Circuit Breaker in the Smart Gateway.

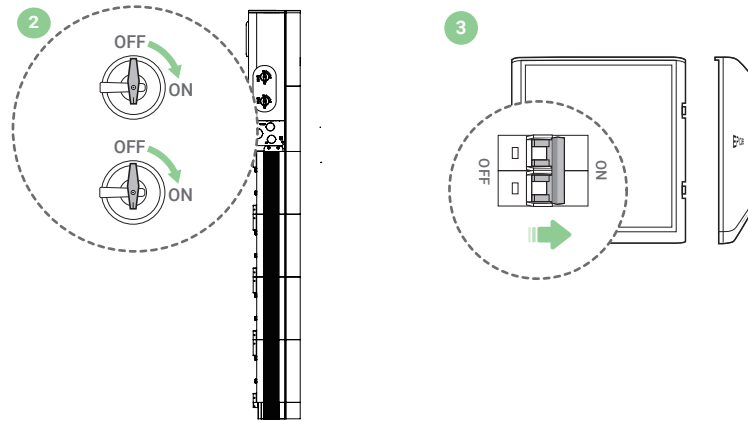

E. De-energize EP Cube System

1. Turn off EP Cube. (Refer to Page 14)
2. Turn off Hybrid circuit breaker in the Smart Gateway.
3. Turn off PV Switches.
4. Turn off Grid Circuit Breaker.

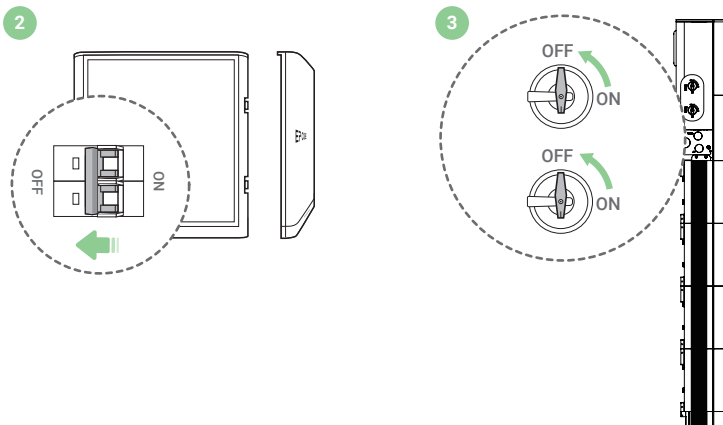

INSTRUCTIONS FOR USE AND CARE

General Operation And Care

A. Care And Notice

If an owner needs to leave for a period of time exceeding 30 days, please ensure that:

1. EP Cube has a dry and clean environment at an ambient temperature of 32°F-95°F (0 °C-35 °C) to protect batteries.
2. Ensure the last charge under 20%-40% SOC (state of charge), and switch off Hybrid to avoid the battery being completely discharged.
3. Charging the batteries once every 6 months to ensure that the batteries will work normally.

B. Visual Inspection

1. Ensure that there is nothing leaning on, stacked on top, or hanging from EP Cube or from wires or conduit leading to EP Cube.
2. Ensure that bracket on the wall is stable. Contact the EP Cube service team if it is loose, detaching or coming off.
3. Ensure that EP Cube internet connection works and system updates are in the latest version.
4. Ensure that ventilation fan area is clear.

(Contact the EP Cube service team if the product is malfunctioning.)

C. Cleaning

- ⚠ Please use a lint-free cloth or vacuum to remove dust and stains on enclosure of the product. The use of organic solvents, corrosive liquids, etc. is prohibited.

INSTRUCTIONS FOR USE AND CARE

Product Update

Updating the firmware to optimize EP Cube performance is of primary importance. Enable the OTA (Over-the-Air Technology) function on the network page of the mobile app. Then your product will be updated automatically whenever there is a new firmware available.

Internet Connection

EP Cube connects to the internet through home WIFI (2.4G).

When offline:

Input the latest WIFI password using EP Cube app configuration page.

Disposal Instruction

The EP Cube product is an electronic product, please do not throw it in the garbage or send to a local landfill! Proper disposal of the batteries is required. Refer to your local codes for disposal requirements.

Warranty

Check the *Limited Warranty* is activated **within 45 days** from the product installation date. If a customer does not check and the warranty is not registered, the customer may fail to claim the *Limited Warranty*.

Check the *Limited Warranty* status on the portal: www.eternalplanetenergy.com

Click steps: Top menu >> Support >> Warranty >> Input Smart Gateway SN (written on the Smart Gateway label) >> Warranty Period (10 years).