

EVM4X, WMVM Cased Cooling Only Evaporator Coil Multipoise

Installation Instructions

NOTE: Read the entire instruction manual before starting the installation.

Safety Considerations

Improper installation, adjustment, alteration, service, maintenance, or use can cause explosion, fire, electrical shock, or other conditions which may cause death, personal injury or property damage. Consult a qualified installer, service agency, or your distributor or branch for information or assistance. The qualified installer or agency must use factory-authorized kits or accessories when modifying this product. Refer to the individual instructions packaged with the kits or accessories when installing.

Follow all safety codes. Wear safety glasses, protective clothing, and work gloves. Use quenching cloth for brazing operations. Have fire extinguisher available. Read these instructions thoroughly and follow all warning or cautions included in literature and attached to the unit. Consult local building codes and the current editions of the National Electrical Code (NEC) NFPA 70.

In Canada, refer to the current editions of the Canadian Electrical Code CSA C22.1.

Recognize safety information. When you see this symbol  on the unit and in instructions or manuals, be alert to the potential for personal injury. Understand the signal words DANGER, WARNING, CAUTION, and NOTE. These words are used with the safety-alert symbol. DANGER identifies the most serious hazards which will result in severe personal injury or death. WARNING signifies hazards which could result in personal injury or death. CAUTION is used to identify unsafe practices which may result in minor personal injury or product and property damage. NOTE is used to highlight suggestions which will result in enhanced installation, reliability, or operation.

WARNING

PROPERTY DAMAGE HAZARD — FURNACE/COIL MATCHING

Failure to follow this warning could result in property damage, personal injury, or death.

This coil must be matched to heating equipment that meets all CSA/ANSI Z21.47 or cooling equipment that meets UL 1995 or UL 60335-2-40. Refer to the furnace/blower installation instructions for any potential considerations when installing coils with composite drain pans.

CAUTION

PARTIAL UNIT REQUIREMENTS

Failure to follow this warning could result in equipment damage. This family of evaporator coils are PARTIAL UNIT AIR CONDITIONER, complying with PARTIAL UNIT requirements of UL/CSA 60335-2-40 Standard, and must only be connected to other units that have been confirmed as complying to corresponding PARTIAL UNIT requirements of this UL/CSA 60335-2-40 Standard.

WARNING

PERSONAL INJURY / PROPERTY DAMAGE HAZARD

Failure to follow this warning could result in property damage, personal injury, or death.

For continued performance, reliability, and safety, the only approved accessories and replacement parts are those specified by the equipment manufacturer. The use of non-manufacturer approved parts and accessories could invalidate the equipment limited warranty and result in fire risk, equipment malfunction, and failure. Please review manufacturer's instructions and replacement part catalogs available from your equipment supplier.

WARNING

ELECTRICAL SHOCK HAZARD

Failure to follow this warning could result in personal injury or death.

Before installing, modifying or servicing system, always turn off main power to system. There may be more than one disconnect switch. Lock out and tag switch with a suitable warning label.

CAUTION

UNIT DAMAGE HAZARD

The coil is **not approved** for Heat Pump application. Unit damage may occur

WARNING

PERSONAL INJURY HAZARD

Failure to follow this caution may result in personal injury.

This coil contains Nitrogen precharge of 7 – 10 PSIG. Release this pressure through the center of the rubber plugs before removing plugs.

WARNING

EXPLOSION HAZARD

Failure to follow this warning could result in death, serious personal injury, and/or property damage.

Never use air or gases containing oxygen for leak testing or operating refrigerant compressors. Pressurized mixtures of air or gases containing oxygen can cause an explosion.



! CAUTION

CUT HAZARD

Failure to follow this caution may result in personal injury. Sheet metal parts may have sharp edges or burrs. Use care and wear appropriate protective clothing and gloves when handling parts.

! CAUTION

UNIT OR PROPERTY DAMAGE HAZARD

Failure to follow this caution may result in property damage. Make sure that Aluminum tubes do not come in direct contact or allow for condensate run off with a dissimilar metal. Dissimilar metals can cause galvanic corrosion and possible premature failure.

IMPORTANT: Nitrogen can leak out through the hole that the needle pierced in the plugs. This does not indicate a leaking coil nor warrant return of the coil.

IMPORTANT: Dry fit all connections to systems (electrical, drains, refrigerant lines, flue & intake, etc.) first to verify no interferences before final connections are made.

Introduction

Use this instruction manual to install indoor coils on upflow, downflow, or horizontal furnaces in cooling applications only. Do not use these coils in heat pump applications. These coils are enclosed in a painted casing, have factory-installed TXVs, and are used with Puron® refrigerant R-410A systems.

Installation

These units can be installed in upflow, downflow, or horizontal configurations. Before installation, there are several performance requirements that must be considered, because poor installation can negatively affect performance. This section will briefly discuss those factors.

Airflow

Airflow amount and distribution are vital to adequate system performance. Problems that can be experienced with incorrect airflow include:

- low system performance
- restricted TXV
- frosted coil
- poor humidity control
- water blow-off

When attaching the coil and building the plenum, pay special attention to the effect these details will have on airflow. After system start-up, check the cfm to insure that it is correct. (Generally, the cfm should be 350 to 450 cfm/ton during normal cooling operation.)

TXV

A thermal expansion valve is utilized in this coil design to optimize performance and comfort throughout the entire operating range of the system. Special attention needs to be taken to the TXV when installing the coil (Fig. 1):

- Do not overheat valve. Temperatures that exceed 212°F (100°C) can harm valve performance. Use a wet cloth or heat sink when brazing.
- Place liquid filter dryer near indoor unit to reduce the risk of debris clogging the valve.
- Make sure TXV bulb is securely fastened with a metal strap and wrapped in the indentation on vapor line tube.

These specific coils have a factory-installed hard-shutoff TXV designed only for use with R-410A refrigerant. Use only with outdoor units designed for R-410A.

NOTE: These TXVs are factory set at approximately 10° superheat measured at the suction service valve, and are **not** field adjustable.

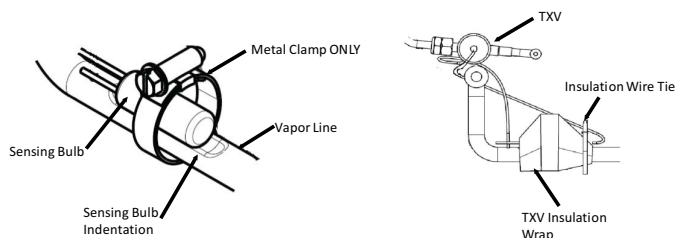

Fig. 1 – TXV Bulb

A210138

Cabinet Sweating

If this unit is installed in a garage, attic, or other unconditioned space, special attention needs to be given to the potential of cabinet sweating. A 6-in (152 mm) wide piece of insulation should be wrapped around the coil casing and supply duct connection point.

Inspect Equipment

File claim with shipper if equipment is damaged.

! CAUTION

ENVIRONMENTAL HAZARD

Failure to follow this caution may result in environmental damage. Federal regulations require that you do not vent refrigerant to the atmosphere. Recover during system repair or final unit disposal.

Select Installation Procedure

NOTE: Furnace coils are not approved to be used in fan coil or “draw-through” type applications.

To install cased coils in upflow applications, follow the instructions below ([Upflow Coil Installation on p3](#)).

To install cased coils in downflow applications, follow the instructions below, ([Downflow Coil Installation on p5](#)).

To install cased coils in horizontal applications, follow the instructions below, ([Horizontal Coil Installation on p5](#)).

See [Table 1](#) for coil connection options. Refer to instructions for placement of coil casing on furnace.

NOTE: We recommend a 4" transition for peak performance, but it is not required unless stated.

! CAUTION

PROPERTY DAMAGE HAZARD

Failure to follow this caution may result in property damage. Installing coils rotated 90° from the front of the furnace, in upflow, downflow, or horizontal applications, may cause water blow-off or coil freeze-up due to the concentration of air on one slab of the coil or lack of air to a slab of the coil. It is required that on this type of application, a field-supplied adapter be placed between the coil and furnace to allow air to distribute properly between all slabs of the coil.

Upflow Coil Installation

The cased coil is designed to fit furnaces of the same width (Fig. 2).

1. Set coil in place on upflow furnace discharge air opening.
2. Ensure coil is level for proper condensate drainage. Do not tip coil toward condensate drain. Coil casing does not need to be fastened or screwed to furnace.

3. When installing wider coil on narrower furnace, it is recommended to use a transition adapter (Fig. 3).

NOTE: On upflow installations where the indoor coil is placed in an unconditioned space, a 6" wide piece of insulation should be applied and wrapped around the outside of the coil casing and supply duct contact point. Consult the furnace installation instructions for any special requirements when installing the coil to the furnace.

Table 1 – Coil Connections / Orientations

| Model | Nom. Tons | Line Set Connection Tube Size, in. | | Flush Fit to Furnace Width, in. (mm) | Fits Next Smaller Furnace Width | | | 90° Rotation to Furnace (4" Min. Transition Required) | 180° Rotation to Furnace |
|---------------------------|-----------|------------------------------------|--------|--------------------------------------|---------------------------------|-------------|--------------|---|--------------------------|
| | | Suction | Liquid | | Equal Overhang | Offset Left | Offset Right | | |
| EVM4X24M17A / WMVM24417XA | 2 | 3/4 | 3/8 | 17-1/2 (445) | X | X | X | ALL Upflow, Downflow, Horizontal Right, Horizontal Left | |
| EVM4X25M17A / WMVM25417XA | 2 | 3/4 | 3/8 | 17-1/2 (445) | X | X | X | | |
| EVM4X30M17A / WMVM30417XA | 2.5 | 3/4 | 3/8 | 17-1/2 (445) | X | X | X | | |
| EVM4X31M17A / WMVM31417XA | 2.5 | 3/4 | 3/8 | 17-1/2 (445) | X | X | X | | |
| EVM4X32M17A / WMVC32417XA | 2.5 | 3/4 | 3/8 | 17-1/2 (445) | X | X | X | | |
| EVM4X36M17A / WMVM36417XA | 3 | 3/4 | 3/8 | 17-1/2 (445) | X | X | X | | |
| EVM4X42M21A / WMVM42421XA | 3.5 | 7/8 | 3/8 | 21 (533) | X | X | X | | |
| EVM4X43M21A / WMVM43421XA | 3.5 | 7/8 | 3/8 | 21 (533) | X | X | X | | |
| EVM4X44M21A / WMVM44421XA | 3.5 | 7/8 | 3/8 | 21 (533) | X | X | X | | |
| EVM4X48M21A / WMVM48421XA | 4 | 7/8 | 3/8 | 21 (533) | X | X | X | | |
| EVM4X49M21A / WMVM49421XA | 4 | 7/8 | 3/8 | 21 (533) | X | X | X | | |
| EVM4X60M21A / WMVM60421XA | 5 | 7/8 | 3/8 | 21 (533) | X | X | X | | |
| EVM4X60M24A / WMVM60424XA | 5 | 7/8 | 3/8 | 24-1/2 (622) | X | X | X | | |
| EVM4X61M24A / WMVM61424XA | 5 | 7/8 | 3/8 | 24-1/2 (622) | X | X | X | | |

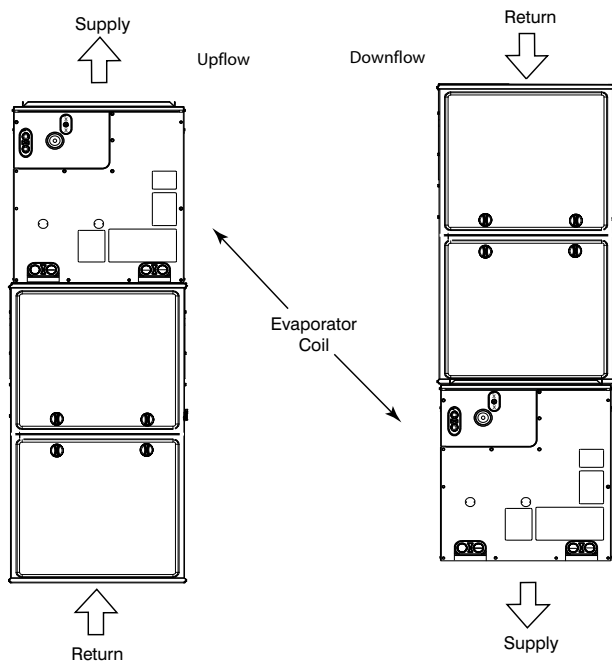

Fig. 2 – Typical Flush-Fit Coil Installation on Furnace (recommended) A221121

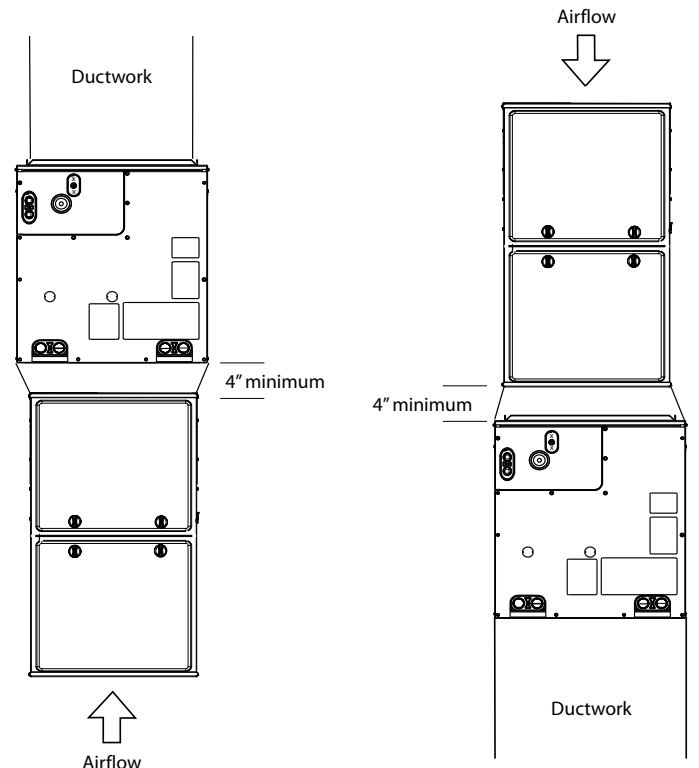

Fig. 3 – Adapter(s) Installation When Coil is Larger than Furnace (recommended) A221122

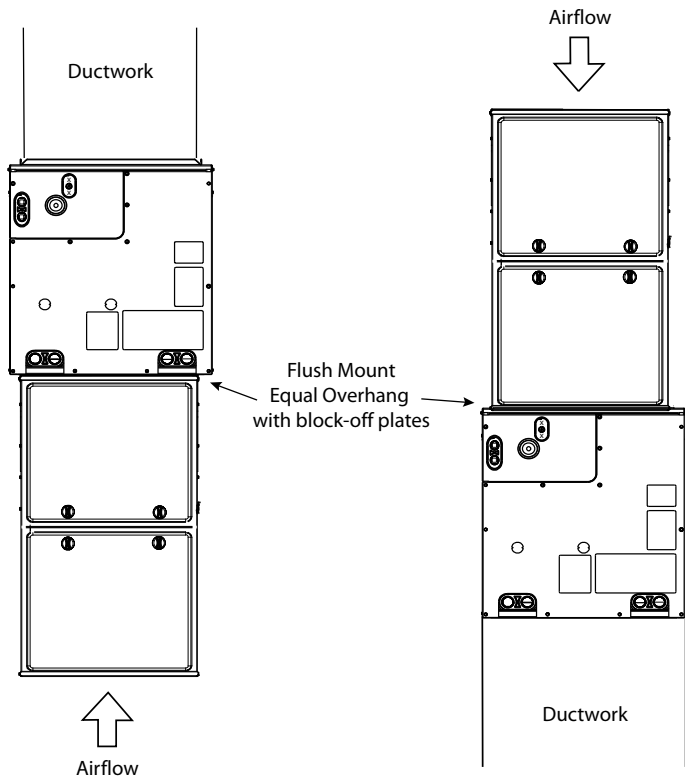

Fig. 4 – Smaller Furnace, Equal Overhang, Flush Mount (not recommended) A221123

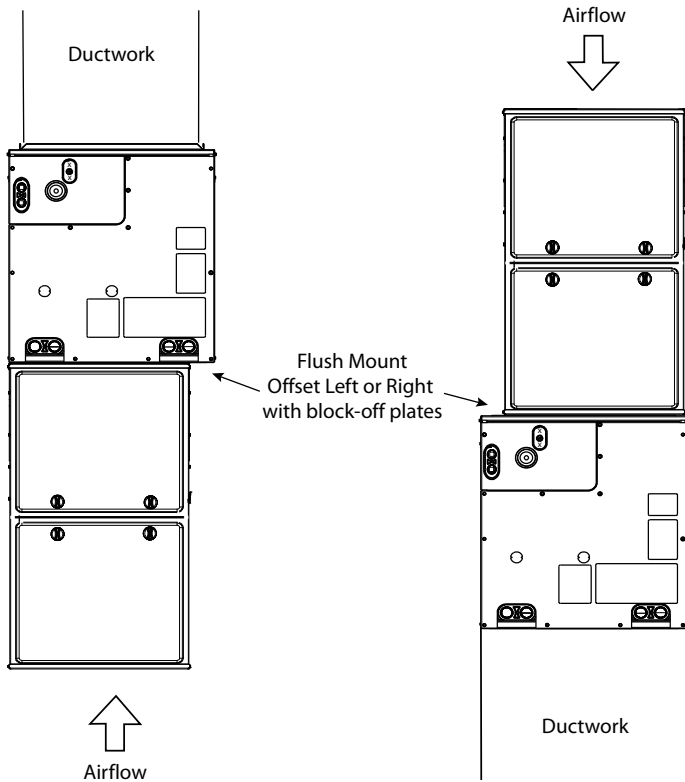

Fig. 5 – Smaller Furnace, Offset, Flush Mount Right or Left (not recommended) A221124

IMPORTANT: Any installation configuration shown here that is noted as **'not recommended'** indicates that this configuration has not been factory tested and therefore full performance specifications have not been certified. In instances where a **'not recommended'** installation configuration is required, it is the responsibility of the installer to ensure all performance criteria is met.

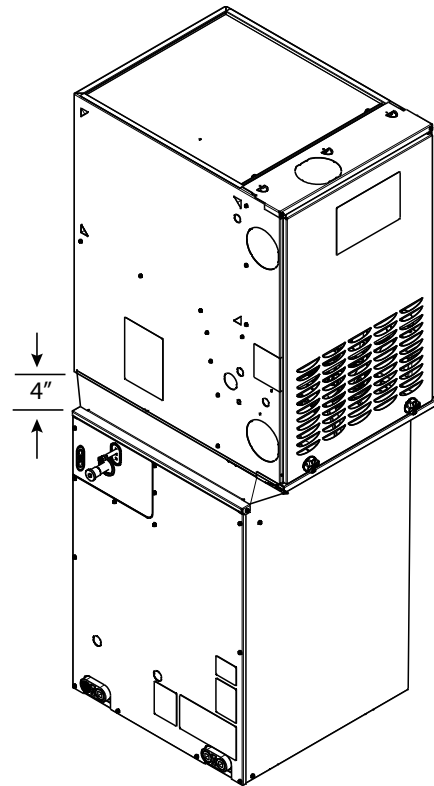

Fig. 6 – 90° Rotation (shown in downflow) 4" Transition Required (not recommended) A221125

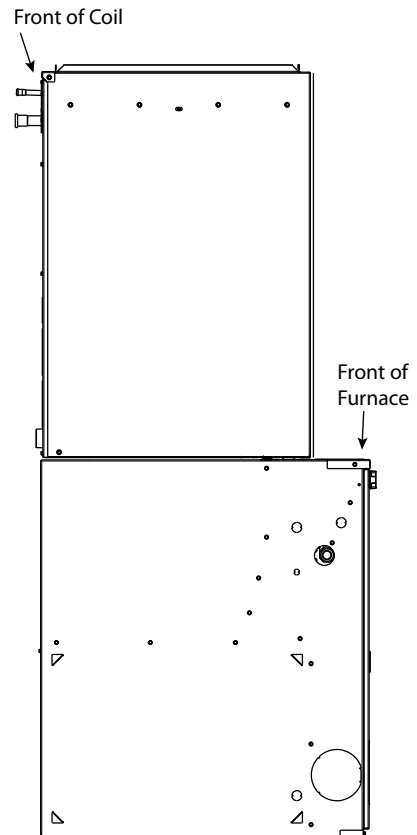

Fig. 7 – 180° Rotation (shown in upflow) (not recommended) A221111

Downflow Coil Installation

NOTE: In downflow installation with a 4-way multipoise furnace, break off perforated duct flanges on furnace. See furnace Installation Instructions.

Horizontal Coil Installation

In horizontal installation with a 4-way multipoise furnace, break off perforated duct flanges on furnace. See furnace Installation Instructions. For condensate connections, use the correct drain lines per Fig. 14.

The unit can be installed on a work platform, secured to roof truss in attic, suspended from hangers on floor joists in crawl space, or installed on blocks. It is designed to allow airflow in either direction, to mate with horizontal-left or horizontal-right furnace installations. Ensure coil cabinet is level side to side and front to back. It is allowable to add up to 1/2-in. additional slope over length and depth of coil cabinet in the direction of drain pan connection (Fig. 8).

NOTE: In horizontal applications, the vertical condensate drain ports must be plugged. When connecting condensate drain lines to the horizontal drain ports, transfer the horizontal drain plugs to the vertical drain pan ports to assure that all vertical drain ports are plugged.

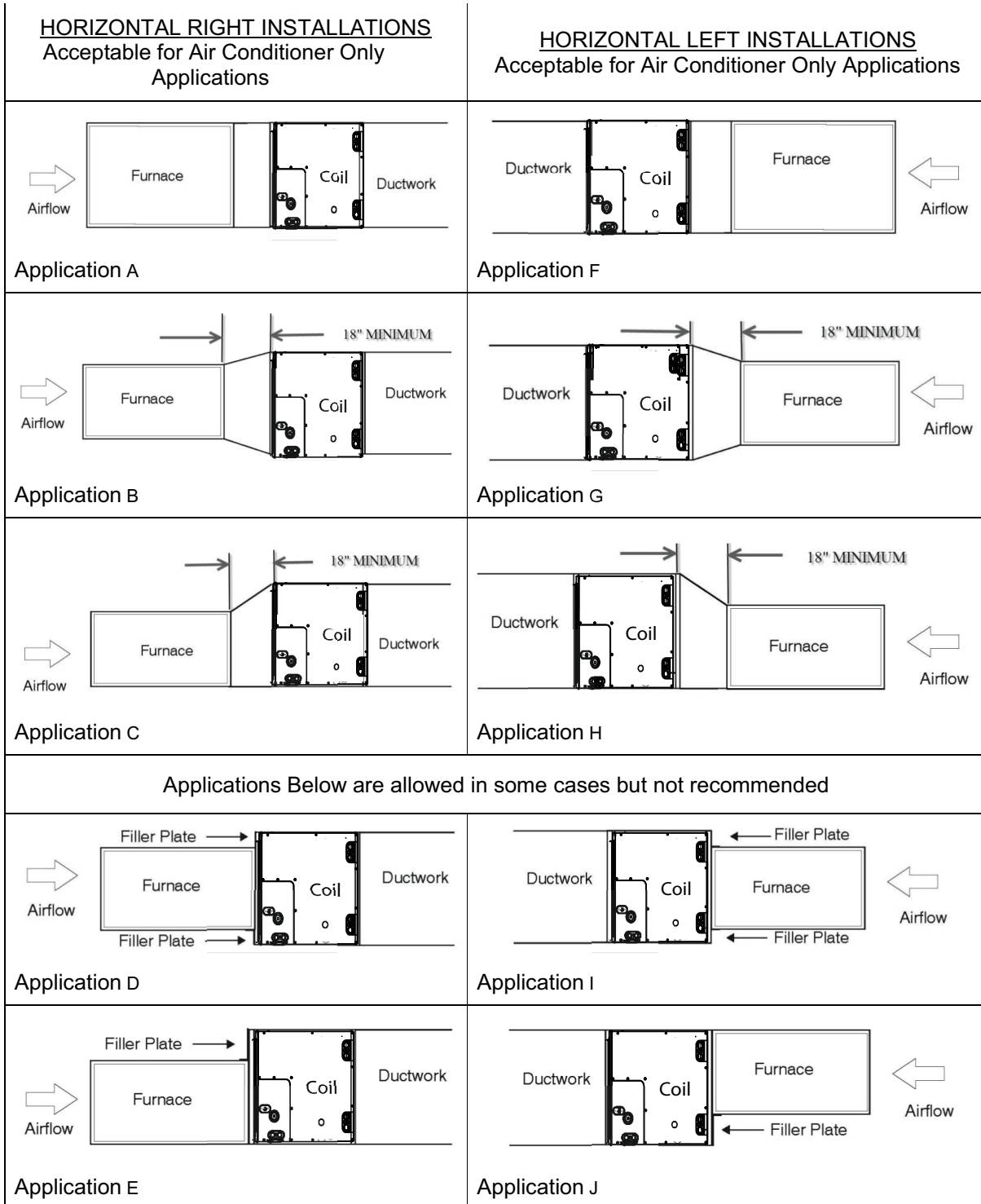

Fig. 8 – Horizontal Installation Applications

Horizontal Right Installation

1. Use field fabricated attachment plates to secure coil to furnace (Fig. 9).
2. Use self-tapping screws to mount attachment plates to coil casing. Install screws no more than 1" from the outer edge to avoid contacting or interfering with internal components.
3. Connect furnace snugly against coil casing.

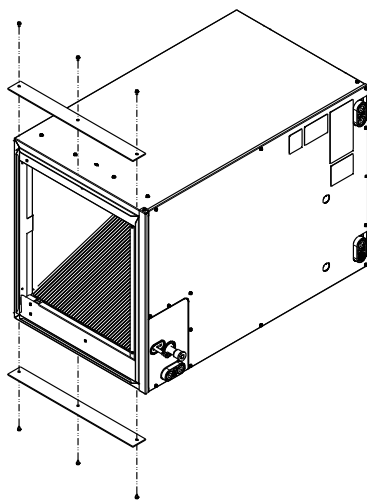

Fig. 9 – Horizontal Right Attachment Plates

A221202

4. Use self-tapping screws to attach furnace (Fig. 10).

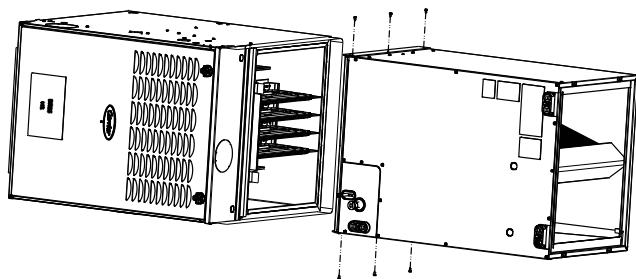

Fig. 10 – Horizontal Right Installation

A221203

5. Seal joint between coil casing and furnace to create an air tight seal using locally approved materials.
6. If coil is wider than furnace, use 4-in. minimum transition and self tapping screws to attach furnace (Fig. 8).

Horizontal Right with Pan Extension (6124 Size Only)

The pan extension is shipped with the unit. There should not be any gaps between the plastic condensate pan and the pan extension. All condensate should flow from the pan extension to the plastic condensate pan and not leak into the coil cabinet or duct.

Install the pan extension onto the right end of the horizontal-condensate pan. The pan extension is slotted to fit onto the condensate pan edge and will extend into the supply plenum (Fig. 11).

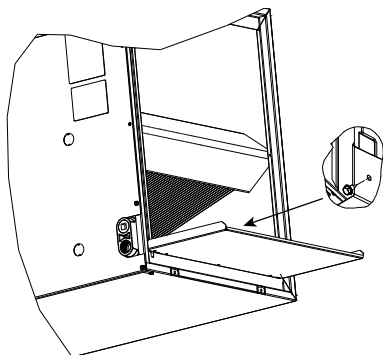

Fig. 11 – Horizontal-Right Pan Extension (6124 size only)

A221204

Horizontal Left Installation

1. Unbend the 4 tabs at the right side of the casing (Fig. 12).
2. Connect furnace snugly against coil casing.

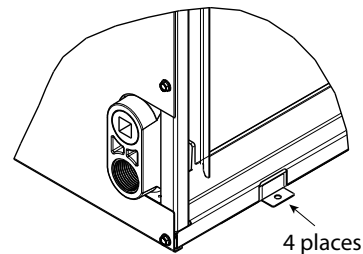

Fig. 12 – Horizontal Left Installation

A221205

3. Use self-tapping screws to attach furnace (Fig. 13).
4. Seal joint between coil casing and furnace to create air tight seal using locally approved materials.
5. If coil is wider than furnace, use 4-in. minimum transition and self tapping screws to attach furnace (Fig. 8).

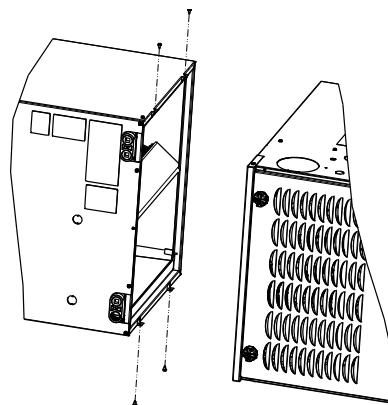

Fig. 13 – Horizontal Left Installation

A221206

Refrigerant Line Connections

CAUTION

WATER MANAGEMENT HAZARD

Failure to follow this caution could cause product and/or property damage.

The furnace coil door must be properly installed when the coil is in operation. To ensure proper condensate water management, the drain pan must not touch the coil. When properly installed the furnace coil door will correctly align the condensate pan with the coil.

WARNING

PERSONAL INJURY HAZARD

Failure to follow this warning could result in personal injury.

Wear eye protection. Coil is factory charged with 7–10 psi nitrogen. The coil is under pressure and TXV screen is in place behind liquid line plug. DO NOT remove liquid line plug first, always remove the suction line plug first to depressurize the coil.

NOTE: Factory nitrogen charge may escape past rubber plugs during storage. This does not indicate leaking coil nor warrant return of the coil. Size and install refrigerant lines according to information provided with outdoor unit. Coil connection tube sizes are shown in Table 1. Route refrigerant lines to the coil in a manner that will not obstruct service access to the unit or removal of the filter.

Do not use damaged, dirty, or contaminated tubing because it may plug refrigerant flow-control device. ALWAYS evacuate the coil and field-supplied tubing before opening outdoor unit service valves.

Connect Refrigerant, Liquid, and Suction Lines

For matched and mismatched systems, use line sizes recommended in outdoor unit Installation Instructions.

CAUTION

UNIT OR PROPERTY DAMAGE HAZARD

Failure to follow this caution may result in property damage. Take precautions to ensure Aluminum tubes do not come in direct contact or allow for condensate run off with a dissimilar metal. Dissimilar metals can cause galvanic corrosion and possible premature failure.

The coil can be connected to outdoor units using field-supplied tubing of refrigerant grade. Always evacuate tubing and reclaim refrigerant when making connections or flaring tubing. Leak check connections before insulating entire suction line.

See [Table 1](#) for coil connection tube size.

1. Remove cabinet access door.
2. Remove rubber plugs, suction plug then liquid plug, from coil stubs using a pulling and twisting motion. Hold coil stubs steady to avoid bending or distorting.
3. Remove fitting door with rubber grommets and slide fitting door with grommets onto the refrigerant lines (field line-set), away from braze joints.

CAUTION

UNIT DAMAGE HAZARD

Failure to follow this caution may result in damage. All aluminum tubing and coils must be adequately shielded from any copper braze splatter.

4. Fit refrigerant lines into coil stubs. Wrap a heat sinking material such as a wet cloth behind braze joints.
5. Wrap TXV and nearby tubing with a heat-sinking material such as a wet cloth.
6. Use 1/2 psig Nitrogen purge in the suction and out the liquid line.
7. Braze using a Sil-Fos or Phos-copper alloy. Do not use soft solder.
8. After brazing, allow joints to cool. Carefully remove TXV bulb insulation and verify that the TXV bulb is securely fastened with hose clamp. Tighten screw a half-turn past hand tight with TXV bulb placed in the indentation with full contact with the vapor line tube. Re-wrap TXV bulb with insulation.
9. Leak check connections before insulating entire suction line.
10. Slide fitting door with rubber grommets over joints. Position tubing at center of each grommet to ensure an air seal around the tube. Reinstall cabinet door.

CAUTION

UNIT DAMAGE HAZARD

Failure to follow this caution may result in product damage. To avoid valve damage to the refrigerant control device while brazing, valves must be wrapped with a heat-sinking material such as a wet cloth.

Refrigerant Metering Device

These Coils have a factory installed hard shut-off TXV designed only for use with R-410A refrigerant. Use only with outdoor units designed for R-410A.

NOTE: These TXVs are factory set at approximately 10° superheat measured at the suction service valve, and are **not** field adjustable.

These furnace coils use an R410A TXV. The TXVs are preset at the factory and do not need adjustment for reliable operation. Reference the outdoor unit instructions to properly charge the unit to the correct subcooling. Let the system stable out approximately 15 minutes after each charge adjustment.

CAUTION

UNIT DAMAGE HAZARD

Failure to follow this caution may result in product damage. DO NOT BURY MORE THAN 36 IN. OF REFRIGERANT TUBING IN GROUND. If any section of tubing is buried, there must be a 6-in. vertical rise to the valve connections on the outdoor unit. If more than the recommended length is buried, refrigerant may migrate to cooler buried section during extended periods of unit shutdown, causing refrigerant slugging and possible compressor damage at start-up.

Condensate Drain Line Connection

CAUTION

PROPERTY DAMAGE HAZARD

Failure to follow this caution may result in property damage. It is required that all drain connections that are not being used be fitted with 3/4-inch male PVC plugs. When installing over a finished ceiling and/or living area, install a field-fabricated secondary condensate pan under the entire unit.

The coil is designed to dispose of accumulated water through built-in condensate drain fittings. It is recommended that PVC fittings be used on the condensate pan. Do not over-tighten. Finger tighten plus 1-1/2 turns. **Be sure to install PVC plugs in all unused condensate drain fittings (if not factory supplied).** Six (6) 3/4-inch female threaded pipe connections are provided in each coil condensate pan.

It is highly RECOMMENDED and in some locals is it a code requirement to install a trap on the drain line(s). Please use the following guidelines to assure proper drainage:

- Install a trap in condensate line of coil as close to the coil as possible.
- Make trap at least 3 inches (76 mm) deep and no higher than the bottom of unit condensate drain opening ([Fig. 14](#)).
- Pitch condensate line 1 inch (25.4 mm) for every 10 ft. of length to an open drain or sump.
- Make sure that the outlet of each trap is below its connection to condensate pan to prevent condensate from overflowing the drain pan.
- Prime all traps, test for leaks, and insulate traps and lines if located above a living area.

CAUTION

PROPERTY DAMAGE HAZARD

Failure to follow this warning could result in property damage. Provide trap with air gap in drain line when connecting to waste (sewer) line.

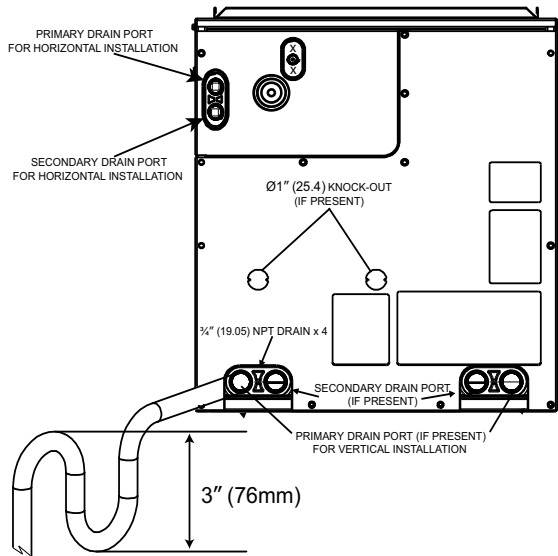

Fig. 14 – Condensate Trap (shown in vertical configuration) A221126

NOTE: If unit is located in or above a living space, where damage may result from condensate overflow, a field-supplied, external condensate pan should be installed underneath the entire unit, and a secondary condensate line (with appropriate trap) should be run from the unit into the pan. Any condensate in this external condensate pan should be drained to a noticeable place. As an alternative to using an external condensate pan, some localities may allow the running of a separate 3/4-inch (19 mm) condensate line (with appropriate trap) per local code to a place where the condensate will be noticeable. The owner of the structure must be informed that when condensate flows from secondary drain or external condensate pan, the unit requires servicing or water damage will occur. To further protect against water damage, install a float switch to shut the unit off if the water in the secondary pan gets too high.

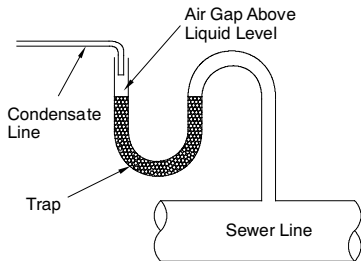

Fig. 15 – Condensate Drain to Waste Line A10216

Waste Line Connection

If the condensate line is to be connected to a waste (sewer) line, an open trap must be installed ahead of the waste line to prevent escape of sewer gases (Fig. 15).

Humidifier Application

When installing a humidifier in a system which contains a V-coil, consideration must be given to location of coil slabs (Fig. 16).

1. The humidifier should be mounted to the supply plenum or return duct whenever possible.
2. Ensure that humidifier has adequate airflow.

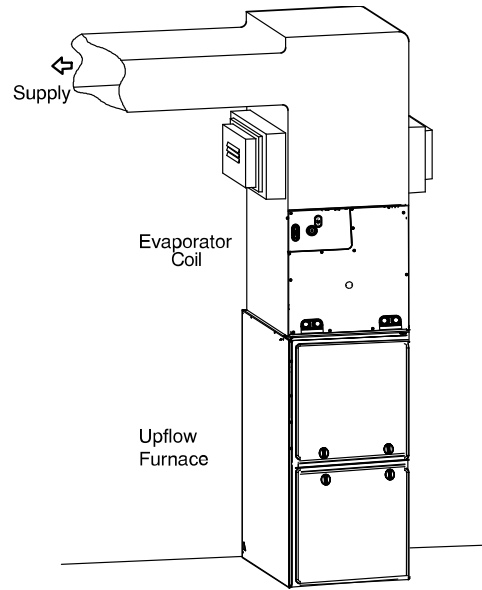

Fig. 16 – Humidifier Application A221127

Care and Maintenance

To continue high performance and minimize possible equipment failure, it is essential that periodic maintenance be performed on this equipment. Consult your local dealer as to the proper frequency of maintenance, but it should be done at least annually.

The ability to properly perform maintenance on this equipment requires certain mechanical skills and tools. If you do not possess these, contact your dealer for maintenance. The only consumer service recommended or required is filter replacement or cleaning on a monthly basis.

CAUTION

ENVIRONMENTAL HAZARD

Failure to follow this caution may result in environmental damage. Remove and recycle all components or materials (i.e., oil, refrigerant, etc.) before unit final disposal.

