



# R32 MULTI F

# MULTI F MAX

## INDOOR UNIT ENGINEERING MANUAL



Multi-Position  
Air Handling Units



Four-Way  
Ceiling Cassette



Art Cool™ Mirror  
Wall-Mounted



Low Wall Console



Mid Static Duct

**Indoor Units for Multi-Zone Heat Pump Systems**  
**7,000 to 36,000 Btu/h**

## **PROPRIETARY DATA NOTICE**

**This document, as well as all reports, illustrations, data, information, and other materials are the property of LG Electronics U.S.A., Inc., and are disclosed by LG Electronics U.S.A., Inc., only in confidence.  
This document is for design purposes only.**

**For more technical materials such as submittals, catalogs, installation, owner's, and service manuals, visit [www.lghvac.com](http://www.lghvac.com).**

Proper sizing and installation of equipment is critical to achieve optimal performance. Split system air conditioners and heat pumps (excluding ductless systems) must be matched with appropriate coil components to meet ENERGY STAR® criteria. Ask your contractor for details or visit [www.energystar.gov](http://www.energystar.gov).

(ENERGY STAR and the ENERGY STAR mark are registered trademarks owned by the U.S. Environmental Protection Agency.)

For continual product development, LG reserves the right to change specifications without notice.  
©LG Electronics Inc.






*This document, as well as all reports, illustrations, data, information, and other materials are the property of LG Electronics U.S.A., Inc.*

# MULTI F MULTI F MAX

# TABLE OF CONTENTS

<b>Unit Nomenclature.....</b>	<b>6</b>	<b>Mid Static Duct Indoor Units .....</b>	<b>124</b>
<b>Functions, Controls and Options Overview.....</b>	<b>7</b>	<i>Mechanical Specifications and Features.....</i>	<i>124</i>
<b>Art Cool Mirror Indoor Units.....</b>	<b>10</b>	<i>General Data / Specifications.....</i>	<i>125</i>
<i>Mechanical Specifications and Features.....</i>	<i>10</i>	<i>Dimensions.....</i>	<i>126</i>
<i>General Data / Specifications.....</i>	<i>11</i>	<i>Cooling Capacity Table.....</i>	<i>127</i>
<i>Dimensions.....</i>	<i>12</i>	<i>Heating Capacity Table.....</i>	<i>128</i>
<i>Cooling Capacity Table.....</i>	<i>14</i>	<i>External Static Pressure / Acoustic Data.....</i>	<i>129</i>
<i>Heating Capacity Table.....</i>	<i>16</i>	<i>Refrigerant Flow Diagrams.....</i>	<i>131</i>
<i>Acoustic Data.....</i>	<i>17</i>	<i>Wiring Diagrams.....</i>	<i>132</i>
<i>Air Velocity and Temperature Distribution.....</i>	<i>18</i>	<i>Factory Supplied Parts and Materials / Installation.....</i>	<i>133</i>
<i>Refrigerant Flow Diagram.....</i>	<i>19</i>	<i>Installation and Best Layout Practices.....</i>	<i>134</i>
<i>Wiring Diagram.....</i>	<i>20</i>	<b>Four-Way Ceiling Cassette Indoor Units .....</b>	<b>143</b>
<i>Factory Supplied Parts and Materials.....</i>	<i>21</i>	<i>Mechanical Specifications and Features.....</i>	<i>143</i>
<i>Installation and Best Layout Practices.....</i>	<i>22</i>	<i>General Data / Specifications.....</i>	<i>144</i>
<b>High Efficiency Wall-Mounted Indoor Units.....</b>	<b>30</b>	<i>Dimensions.....</i>	<i>145</i>
<i>Mechanical Specifications and Features.....</i>	<i>30</i>	<i>Cooling Capacity Table.....</i>	<i>147</i>
<i>General Data / Specifications.....</i>	<i>31</i>	<i>Heating Capacity Table.....</i>	<i>149</i>
<i>Dimensions.....</i>	<i>32</i>	<i>Acoustic Data.....</i>	<i>151</i>
<i>Cooling Capacity Table.....</i>	<i>34</i>	<i>Air Velocity and Temperature Distribution.....</i>	<i>153</i>
<i>Heating Capacity Table.....</i>	<i>37</i>	<i>Refrigerant Flow Diagram.....</i>	<i>155</i>
<i>Acoustic Data.....</i>	<i>39</i>	<i>Wiring Diagram.....</i>	<i>156</i>
<i>Air Velocity and Temperature Distribution.....</i>	<i>41</i>	<i>Factory Supplied Parts and Materials.....</i>	<i>157</i>
<i>Refrigerant Flow Diagram.....</i>	<i>43</i>	<i>Installation and Best Layout Practices.....</i>	<i>158</i>
<i>Wiring Diagram.....</i>	<i>44</i>	<b>One-Way Ceiling Cassette Indoor Units .....</b>	<b>166</b>
<i>Factory Supplied Parts and Materials.....</i>	<i>45</i>	<i>Mechanical Specifications and Features.....</i>	<i>166</i>
<i>Installation and Best Layout Practices.....</i>	<i>46</i>	<i>General Data / Specifications.....</i>	<i>167</i>
<b>Low Wall Console Indoor Units.....</b>	<b>54</b>	<i>Dimensions.....</i>	<i>168</i>
<i>Mechanical Specifications and Features.....</i>	<i>54</i>	<i>Cooling Capacity Table.....</i>	<i>169</i>
<i>General Data / Specifications.....</i>	<i>55</i>	<i>Heating Capacity Table.....</i>	<i>171</i>
<i>Dimensions.....</i>	<i>56</i>	<i>Acoustic Data.....</i>	<i>173</i>
<i>Cooling Capacity Table.....</i>	<i>57</i>	<i>Air Velocity and Temperature Distribution.....</i>	<i>175</i>
<i>Heating Capacity Table.....</i>	<i>59</i>	<i>Refrigerant Flow Diagram.....</i>	<i>177</i>
<i>Acoustic Data.....</i>	<i>60</i>	<i>Wiring Diagram.....</i>	<i>178</i>
<i>Air Velocity and Temperature Distribution.....</i>	<i>62</i>	<i>Factory Supplied Parts and Materials.....</i>	<i>179</i>
<i>Refrigerant Flow Diagram.....</i>	<i>63</i>	<i>Installation and Best Layout Practices.....</i>	<i>180</i>
<i>Wiring Diagram.....</i>	<i>64</i>	<b>Multi Position Air Handling Unit Indoor Units.....</b>	<b>188</b>
<i>Factory Supplied Parts and Materials.....</i>	<i>65</i>	<i>Mechanical Specifications and Features.....</i>	<i>188</i>
<i>Installation and Best Layout Practices.....</i>	<i>67</i>	<i>General Data / Specifications.....</i>	<i>189</i>
<b>Low Static Duct Indoor Units .....</b>	<b>76</b>	<i>Dimensions.....</i>	<i>191</i>
<i>Mechanical Specifications and Features.....</i>	<i>76</i>	<i>Cooling Capacity Table.....</i>	<i>193</i>
<i>General Data / Specifications.....</i>	<i>77</i>	<i>Heating Capacity Table.....</i>	<i>196</i>
<i>Dimensions.....</i>	<i>78</i>	<i>External Static Pressure.....</i>	<i>199</i>
<i>Cooling Capacity Table.....</i>	<i>79</i>	<i>Heater Capacities.....</i>	<i>200</i>
<i>Heating Capacity Table.....</i>	<i>81</i>	<i>Acoustic Data.....</i>	<i>201</i>
<i>External Static Pressure.....</i>	<i>82</i>	<i>Refrigerant Flow Diagram.....</i>	<i>203</i>
<i>Acoustic Data.....</i>	<i>83</i>	<i>Wiring Diagram.....</i>	<i>204</i>
<i>Refrigerant Flow Diagram.....</i>	<i>84</i>	<i>DIP Switch Settings.....</i>	<i>207</i>
<i>Wiring Diagram.....</i>	<i>86</i>	<i>Factory Supplied Parts and Materials.....</i>	<i>208</i>
<i>Factory Supplied Parts and Materials.....</i>	<i>88</i>	<i>Installation and Best Layout Practices.....</i>	<i>209</i>
<i>Installation and Best Layout Practices.....</i>	<i>89</i>	<b>Application Guidelines.....</b>	<b>217</b>
<b>Convertible Mid Static Duct Indoor Units.....</b>	<b>99</b>	<i>Equipment Selection Procedure.....</i>	<i>218</i>
<i>Mechanical Specifications and Features.....</i>	<i>99</i>	<i>Placement Considerations.....</i>	<i>226</i>
<i>General Data / Specifications.....</i>	<i>100</i>	<b>Refrigerant Piping Design .....</b>	<b>233</b>
<i>Dimensions.....</i>	<i>101</i>	<i>Design Guideline Summary.....</i>	<i>233</i>
<i>Cooling Capacity Table.....</i>	<i>102</i>	<i>Creating a Balanced System / Manual Layout Procedure.....</i>	<i>237</i>
<i>Heating Capacity Table.....</i>	<i>104</i>	<i>Condensate Drain Piping.....</i>	<i>238</i>
<i>External Static Pressure / Acoustic Data.....</i>	<i>106</i>	<b>Electrical Connections.....</b>	<b>240</b>
<i>Refrigerant Flow Diagrams.....</i>	<i>110</i>	<i>General Information.....</i>	<i>240</i>
<i>Wiring Diagrams.....</i>	<i>111</i>	<i>Multi F Systems.....</i>	<i>244</i>
<i>Factory Supplied Parts and Materials / Installation.....</i>	<i>112</i>	<i>Multi F MAX Systems.....</i>	<i>246</i>
<i>Installation and Best Layout Practices.....</i>	<i>113</i>	<i>Multi F with LGRED Systems.....</i>	<i>247</i>
		<i>Multi F MAX with LGRED Systems.....</i>	<i>248</i>
		<i>Remote Controller Connections.....</i>	<i>249</i>
		<i>Indoor Unit Group Control.....</i>	<i>250</i>

# TABLE OF SYMBOLS

 A2L	Indicates that this appliance uses a flammable refrigerant. If the refrigerant leaks and is exposed to an external ignition source, there is a risk of fire.
 <b>DANGER</b>	Indicates a hazardous situation that, if not avoided, WILL RESULT IN DEATH OR SERIOUS INJURY. <sup>1</sup>
 <b>WARNING</b>	Indicates a hazardous situation that, if not avoided, COULD RESULT IN DEATH OR SERIOUS INJURY. <sup>1</sup>
 <b>CAUTION</b>	Indicates a hazardous situation that, if not avoided, COULD RESULT IN MINOR OR MODERATE INJURY. <sup>1</sup>
<b>NOTICE</b>	Indicates information considered important, but not hazard-related; indicates situations that may result in equipment or property damage accidents. <sup>1</sup>
	This symbol indicates an action that should not be performed.

<sup>1</sup>Signal words, symbols, and definitions taken from American National Standards Institute (ANSI) Z535.6. See <https://www.ansi.org/> for more information.



## R32 Refrigerant



LG Electronic split system heating and air conditioning (HVAC) products now contain R32 refrigerant. While R32 refrigerant is slightly flammable, it has a higher efficiency, a lower Global Warming Potential (GWP) value, and is more environmentally friendly than R410A.

R32 Ozone Depletion Potential (ODP) Value: 0.



R32 Global Warming Potential (GWP) Value: 675.

The amount of refrigerant depends on outdoor unit to indoor unit configuration. All refrigerant piping system components (copper piping, joints, and other fittings) must be selected and installed to conform with Refrigeration Safety Regulation standards. Use LG Air Conditioner Technical Solution (LATS) Software to verify the refrigerant amount needed for each installation.

### **WARNING**

- This HVAC system contains fluorinated greenhouse gases in the form of R32 refrigerant.  Do not leak refrigerant gas into the atmosphere.
- Only use R32 as the refrigerant in these HVAC systems. If other substances are added, it may cause an explosion.
- R32 refrigerant is slightly flammable. When handled properly, it does not leak. If the refrigerant leaks in the installation area and comes in contact with a flame, it may generate a fire and / or harmful gas.
- If a leak occurs, immediately turn off any combustion devices, ventilate the installation area, and contact the dealer / contractor where the HVAC unit was purchased.  Do not operate the unit until the refrigerant leaked is repaired.

### **CAUTION**

- Piping wall thickness must comply with all applicable local, state, and federal regulations for the design pressures listed by the manufacturer.  Unapproved piping must not be used.
- To prevent piping from softening,  do not heat the piping more than necessary.

## About LG Electronics, Inc.

LG Electronics is a global leader and technology innovator in consumer electronics, mobile communications, and home appliances. LG Electronics comprises five business units—Home Entertainment, Mobile Communications, Air Conditioning, Business Solutions, and Home Appliance. LG is one of the world's leading producers of flat panel televisions, audio and video products, mobile handsets, air conditioners, and washing machines. LG's commercial air conditioning business unit was established in 1968 and has built its lineup of residential and commercial products to include VRF, Multi F, duct-free split systems, packaged terminal air conditioners (PTACs), and room air conditioners. In 2011, the air conditioning and energy solutions business unit grew to include LED lighting and solar products. For more information, visit [www.lg.com](http://www.lg.com).

## Multi-Zone Systems

LG HVAC systems offer a range of solutions that are cost efficient, quiet and attractive. Multi-zone systems are "split" into indoor and outdoor units, and provide a smart alternative to both central HVAC and window-mounted air conditioners. These inverter heat pump systems are available in a variety of configurations to suit different cooling and heating situations. Installation by a trained HVAC contractor is safe and easy – little to no duct work or sheet metal is required.

### Multi F Systems

LG's inverter heat pumps can support two, three, or four indoor units that are typically installed in separate rooms. Indoor units can be used

#### Benefits of Multi F Systems

- Individual zone control
- Long refrigerant piping lengths
- High refrigerant piping elevation differences
- Maximum flexibility
- Operating ranges of 14°F to 118°F (DB) in cooling and -4°F to 75°F (DB) in heating if connected to standard Multi F Outdoor Units or -13°F to 75°F (DB) in heating if connected to Multi F with LG RED° Outdoor Units.
- Quiet and comfortable environment
- Reduced ductwork



with different controllers, allowing the customer to set the temperature individually. Indoor units are available in several different configurations: Art Cool™ Mirror-mounted, standard wall-mounted, low wall console, four-way ceiling cassettes, ducted, and multi position air handling models. Multi F MAX systems can operate up to eight indoor units through two-, three-, or four-port branch distribution units.

### Adaptable and Flexible

Multi F outdoor units can be adapted to a wide range of building applications and sizes such as schools, hotels, hospitals, offices, and residences. The system components are lightweight and compact so they can be placed in buildings without expensive cranes, they easily fit into most service elevators, and they can be set in place with minimal structural reinforcements requirements.

Multi F technology allows you to pipe farther by reaching areas of the building that would require the installation of a second system when using traditional direct-expansion cooling and heating equipment. Multi F provides the designer with uncompromising pipe system engineering flexibility—long pipe runs and large elevation differences. Whether your building is a condominium, a hotel, a school, or an office complex, Multi F is best suited to reach the farthest corners and elevations.

### Smaller Chases and Plenums

LG Multi F systems use refrigerant piping to move heat, resulting in smaller space requirements for piping as compared to chilled water or roof top systems. This helps reduce the overall construction and material cost of the building, and gives back leasable space. Flexible and logical placement of system components, reduced back-and-forth pipe lengths, and fewer joints lowers installation costs and minimizes potential leaking.

### Quality Commitment

LG is committed to the success of duct-free projects. We provide technical support during installation and commissioning. LG offers a variety of classes designed for installers and servicers on Multi F installation. Classes are conducted at LG's training centers and in field locations at various times throughout the year and on special request.

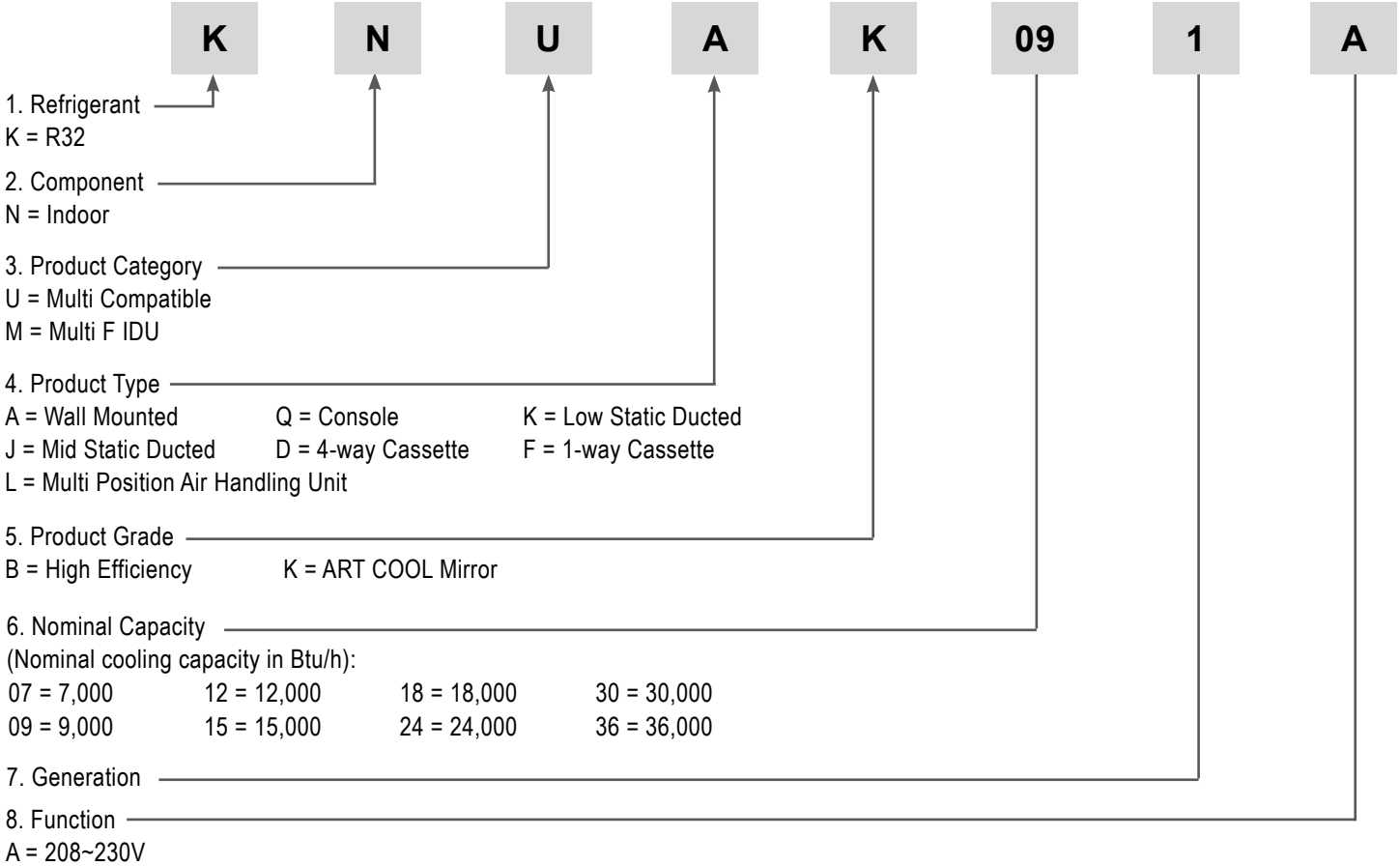


MULTI F MAX

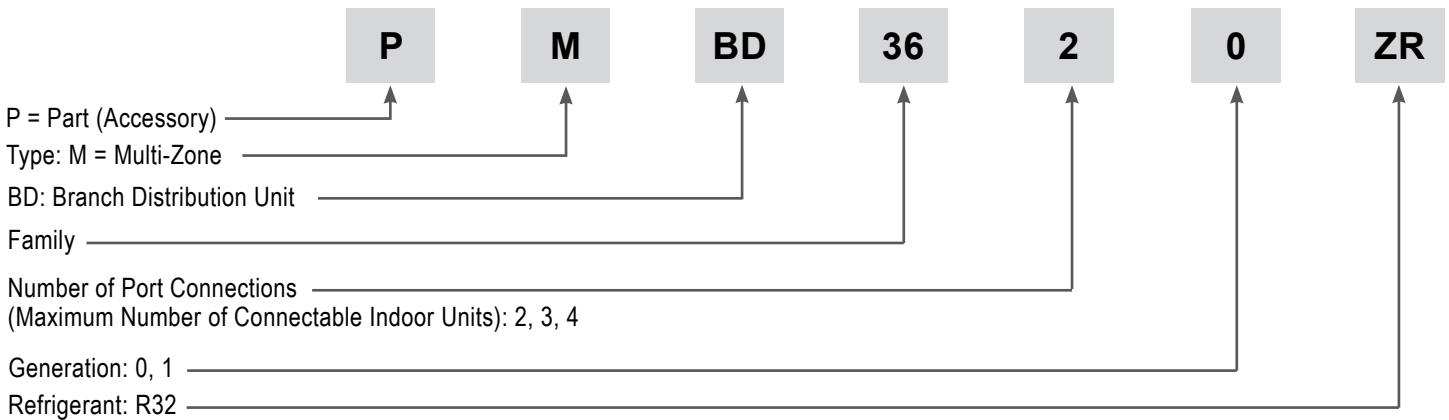


MULTI

## Multi-Zone Systems — Indoor Units



## Branch Distribution Units



### NOTICE

- Voltage for all equipment is 208-230V, 60 Hz, 1-phase.
- All indoor units are compatible with wired controllers.
- All outdoor units are LGAP control network compatible with integrated central control connection.
- Compatible single zone IDU nomenclature is listed in the Single Zone IDU Engineering Manual.

Table 1: Indoor Units—Functions, Controls and Options.

Indoor Unit Type		ART COOL™ Mirror Wall Mounted	High Efficiency Wall Mounted	Low Wall Console	Low Static Duct	Convertible Mid Static Duct	Mid Static Duct	1-Way Ceiling Cassette	Four-Way Ceiling Cassette	Multi Position Air Handling Unit
Airflow	Air supply outlets	1	1	2	1	1	1	1	4	1
	Airflow direction (left/right)	Auto	Auto	Manual				√		
	Airflow direction (up/down)	Auto	Auto	Auto				√	Auto	
	Auto swing (left/right)	√	√					√		
	Auto swing (up/down)	√	√	√				√	√	
	Airflow steps (fan/cool/heat)	6 / 6 / 6	6 / 6 / 6	5 / 5 / 5	3 / 3 / 3	3 / 3 / 3	3 / 3 / 3	4 / 5 / 5	4 / 5 / 4	3 / 3 / 3
	Comfort Air (random fan speed)	√	√	√					√	
	Jet-cool/Jet Heat (power wind)	√	√	√				√	√	
	Swirl wind								√	
Filter	Washable <sup>1</sup>	√	√	√	√	√	√	√	√	
	3M Micro Dust Filter <sup>2</sup>	√	√							
	Ventilation								√	
Operation	Drain pump				√	√	√	√	√	
	E.S.P. control				√	√	√			
	Electric heater									o
	High ceiling <sup>3</sup>							√	√	
	Hot Start	√	√	√	√	√	√	√	√	√
	Self diagnostics	√	√	√	√	√	√	√	√	√
	Soft Dry (dehumidification)	√	√		√	√	√	√	√	√
	Auto operation	√	√	√	√	√	√	√	√	√
	Auto clean (coil dry)	√	√					√		
	Auto restart	√	√	√	√	√	√	√	√	
	Child lock	o	o	√ <sup>4</sup>	o	o	o	√	o	o
	Forced operation	√	√	√				√	√	
	Group control	o	o	√ <sup>4</sup>	o	o	o	o	o	o <sup>3</sup>
	Sleep mode	√	√	√	√	√	√	√	√	√
	Timer (on/off)	√	√	√	√	√	√	√	√	√
	Weekly schedule	o	o	√	√	√	√	√	o	√
Two thermistor control	o	o	√	o	o	o	√	o	o	
Controllers	7-Day programmable controller	o	o	o	o	o	o	o	o	o
	Deluxe wired remote controller	o	o	o	o	o	o	o	o	o
	Wireless LCD remote control	√	√	√	o <sup>4</sup>	o <sup>4</sup>	o <sup>4</sup>	√	√	o <sup>4</sup>
	Dry contact	o	o	o	o	o	o	o	o	o
	Dry contact (temperature setting)	o	o	o	o	o	o	o	o	o
	Central control (LGAP)	√	√	√	√	√	√	√	√	√
Special Function	Wi-Fi	√	√	o	o	o	o	√	o	o
	R32 Refrigerant leak detector	√	√	√	√	√	√	√	√	√

<sup>1</sup>Primary washable filters.

√ = Standard feature

<sup>2</sup>Secondary filter

o = Unit option

<sup>3</sup>Group control will affect available features

<sup>4</sup>Requires wired zone controller

# FUNCTIONS, CONTROLS AND OPTIONS OVERVIEW

MULTI F  
MULTI F MAX

Table 2: Indoor Unit Accessories Overview.

Model No.	Description
<i>For Four-Way Ceiling-Cassette Indoor Units</i>	
PT-QAGW0	Ceiling Grille
PTDCQ	Decorative Cover
PRARH1	Aux Heat Relay Kit
PWFMD200	Wi-Fi Module
<i>For 1-Way Ceiling-Cassette Indoor Units</i>	
PT-UCA	Ceiling Grille
PRARH1	Aux Heat Relay Kit
<i>For Wall-Mounted Indoor Units</i>	
PRARS1	Aux Heat Relay Kit
<i>For Low Wall Console Units</i>	
PWFMD200	Wi-Fi Module
PRARH1	Aux Heat Relay Kit
<i>For Multi Position Air Handling Units</i>	
PNDFA0	Downflow Conversion Kit
ANEH033C1	3 kW Electric Heater (12-36MBH)
ANEH053C1	5 kW Electric Heater (12-36MBH)
ANEH083C2	8 kW Electric Heater (12-36MBH)
ANEH103C2	10 kW Electric Heater (18-36MBH)
ANEH153C3	15 kW Electric Heater (36MBH)
PRARH1	Aux Heat Relay Kit
PWFMD200	Wi-Fi Module
<i>For Low Static Indoor Units</i>	
PWFMD200	Wi-Fi Module
PRARH1	Aux Heat Relay Kit
<i>For Convertible Mid Static Duct Indoor Units</i>	
ABDAMA0	Vertical Installation Conversion Kit
ZFBXMA01A	High Efficiency Filter Box (9-24MBH)
PRARH1	Aux Heat Relay Kit
PWFMD200	Wi-Fi Module
<i>For Mid Static Indoor Units</i>	
ZFBXM201A	High Efficiency Filter Box (30-36MBH)
PRARH1	Aux Heat Relay Kit
PWFMD200	Wi-Fi Module
<i>Controls Accessories</i>	
PWLSSB21H <sup>1</sup>	Wireless Handheld Remote (Cassette/Duct/MPAHU)
AKB76044208	Wireless Handheld Remote (Wall-Mounted)
AKB75735427	Wireless Handheld Remote (Low Wall Console)
AKB75735428	Wireless Handheld Remote (4-way Cassette)
PREMTC00U	Simple Controller
PREMTB100	Standard III Remote Controller (White Housing)
PREMTBB10	Standard III Remote Controller (Black Housing)
PREMTBVC2	MultiSITE™ CRC2 Controller
PREMTBVC3	MultiSITE™ CRC2+ Controller
PREMTBVC4	MultiSITE™ CRC2+Z Controller
PDRYCB100	Dry Contact (Simple)
PDRYCB320	Dry Contact (3rd party controller)
PDRYCB400	Dry Contact (Setback)
ZRTBS01	Remote Temp Sensor (Cassette/Console/Duct/VAHU)
PZCWRCG3	Group Control Cable Kit
PZCWRC1	Controller Extension Cable
<i>Refrigerant Release Mitigation Accessories</i>	
PRHPZ010A	Single Port Shutoff Valve
PLDCAA0S	Alarm Kit

<sup>1</sup>A wired controller is required for duct/MPAHU indoor units to use an accessory handheld remote.

Due to our policy of continuous product innovation, some specifications may change without notification.  
©LG Electronics U.S.A., Inc., Englewood Cliffs, NJ. All rights reserved. "LG" is a registered trademark of LG Corp.

# ART COOL™ MIRROR INDOOR UNIT DATA

**Mechanical Specifications on page 10**

**General Data / Specifications on page 11**

**Dimensions on page 12**

**Cooling Capacity Table on page 14**

**Heating Capacity Table on page 16**

**Acoustic Data on page 17**

**Air Velocity and Temperature Distribution on page 18**

**Refrigerant Flow Diagram on page 19**

**Wiring Diagram on page 20**

**Factory Supplied Parts and Materials on page 21**

**Installation and Best Layout Practices on page 22**

# ART COOL MIRROR INDOOR UNITS

## Mechanical Specifications and Features

MULTI F  
MULTI F MAX

### ART COOL Mirror Wall-Mounted Indoor Units

#### General

All LG indoor units are factory assembled, wired, piped, and provided with a control circuit board, fan, and motor. ART COOL Mirror Wall-Mounted indoor units have a sound rating no higher than 44 dB(A) as tested per KSA0701 ISO Standard 3745.

#### Coil

Indoor unit coils are comprised of a minimum of two rows of aluminum fins mechanically bonded to copper tubing. The coils are pressure tested at the factory. Each unit is provided with a factory installed condensate drain pan below the coil.

#### Refrigerant System

System is designed for use with R32 refrigerant. The refrigeration circuit is pressure-tested at the factory and shipped with a holding charge of helium gas. Refrigerant pipe connections are 45° flare. All refrigerant lines from the outdoor unit to the indoor units must be field insulated.

#### Electrical

Each indoor unit is designed to operate using 208–230/60/1 power with voltage variances of ±10%.

#### Casing

Units are designed to mount on a vertical surface, and are shipped with a separate back plate that secures the unit to the wall, protruding no more than nine (9) inches. Unit is designed so that refrigerant piping can be installed in one (1) of four (4) different directions.

#### Finish

The Art Cool Mirror unit has a flat, architectural panel with a smoked charcoal mirror finish. Unit casing has a dark grey finish and is manufactured of heavy-duty acrylonitrile butadiene styrene (ABS) and high impact polystyrene (HIPS) plastic.

#### Fan Assembly and Control

The unit has a single, direct-drive, crossflow fan made of high strength ABS plastic. The fan motor is brushless digitally controlled (BLDC) with permanently lubricated and sealed ball bearings. The fan and motor assembly is mounted on vibration attenuating rubber grommets. Fan speed is controlled using a microprocessor-based direct digitally controlled algorithm that provides pre-programmed, field-selectable fixed or auto fan speeds in the Heating and Cooling modes. For Art Cool Mirror Wall-Mounted units, the indoor fan has Low, Med, High, Jet Cool and Auto settings for Cooling mode; and has Low, Med, High, Jet Heat and Auto settings for Heating mode. The Auto setting adjusts the fan speed based on the difference between the controller setpoint and space temperature.

#### Air Filter

Return air inlet has a factory-supplied primary removable, washable filter. The unit is also equipped with a secondary 3M Micro Dust filter. Filters are accessed from the front of the unit without the use of tools.

### Features

- Inverter (Variable speed fan)
- Comfort Air
- 3M filter
- Jet cool/Jet heat
- Group Control
- Self-cleaning indoor coil
- Auto operation
- Auto restart operation
- Built-in wi-fi
- Dehumidifying function
- Self diagnosis function
- Wireless LCD remote control included

Figure 1: Multi F Art Cool Mirror Wall-Mounted Indoor Unit.



#### Airflow Guide Vanes

A motorized guide vane is factory installed, and allows the ability to control the direction of airflow from side to side. A motorized louver provides an automatic change in airflow by directing the air up and down to provide uniform air distribution.

#### Microprocessor Control

The indoor unit is provided with an integrated control panel to communicate with the outdoor unit. All unit operation parameters are stored in non-volatile memory resident on the unit microprocessor. The microprocessor controls space temperature through using the value provided by the temperature sensor within the indoor unit. The microprocessor control will activate indoor unit operation when the indoor room temperature falls below or rises above a setpoint temperature, at which point, a signal is sent to the outdoor unit to begin the appropriate mode. The microprocessor will also provide self-diagnostics and auto restart functions. A field-supplied three-wire power cable (3 x 14 AWG) and two-wire communications cable (2 x 18 AWG) must be installed to connect the indoor unit(s) to the outdoor unit.

#### R32 Refrigerant Leak Detector

The indoor unit has a built-in R32 refrigerant leak detection sensor designed to communicate with release mitigation devices and third party alarms, and transmit a system error code upon detection of a refrigerant leak or sensor failure / expiration.

#### Shut-off Valve

LG single-port shutoff valve (PRHPZ010A; sold separately) is available as an accessory.

#### Controls

The indoor unit casing has a factory-standard, integral infrared sensor designed to communicate with the supplied LG wireless handheld remote controller. An optional LG supplied wired controller is available as an additional accessory. Communication between the indoor units and the outdoor unit is accomplished through 18 AWG, two-core, stranded and shielded communication cable. The indoor unit has built-in wi-fi and can be controlled with LG's SmartThinQ app on a smart device. A field-supplied wi-fi network and smart device are required. The SmartThinQ app is free and is available for Android and iOS smart devices.

#### Condensate

The unit is designed for gravity draining of condensate and includes a flexible drain hose capable of installation in one of two directions.

Table 3: Multi F Art Cool Mirror Indoor Unit General Data.

Model Name	KNUAK091A	KNUAK121A	KNUAK181A
Nominal Cooling Capacity (Btu/h) <sup>1</sup>	9,000	12,000	18,000
Nominal Heating Capacity (Btu/h) <sup>1</sup>	10,900	13,600	21,600
<i>Operating Range</i>			
Cooling (°F WB)	57-77		
Heating (°F DB)	59-81		
<i>Fan</i>			
Type	Cross Flow		
Motor Output (W) x Qty.	30 x 1		58 x 1
Motor/Drive	Brushless Digitally Controlled / Direct		
Airflow Rate CFM (H/M/L)	268 / 218 / 169	282 / 233 / 177	558 / 438 / 353
<i>Unit Data</i>			
Refrigerant Type <sup>2</sup>	R32		
Refrigerant Control	EEV		
Power Supply V, Ø, Hz <sup>3</sup>	208-230, 1, 60		
Rated Amps (A)	0.4		
Sound Pressure Level dB(A) (H/M/L) <sup>4</sup>	36 / 32 / 27	38 / 34 / 29	44 / 38 / 34
Dimensions (W x H x D, in.)	32-15/16 x 12-1/8 x 7-9/16		39-9/32 x 13-19/32 x 8-11/32
Net Unit Weight (lbs.)	22.7		27.8
Shipping Weight (lbs.)	24.5		33.5
Power Wiring Cable (No. x AWG) <sup>5</sup>	3 x 14		
Communications Wiring Cable (No. x AWG) <sup>5</sup>	2 x 18		
Heat Exchanger (Row x Column x Fin / inch) x Number	(2 x 23 x 22) x 1		(2 x 16 x 20) x 1
Dehumidification Rate (pts/hr)	2.70	2.75	5.50
<i>Pipe Size</i>			
Liquid (in.)	1/4		
Vapor (in.)	3/8		1/2
<i>Connection Size</i>			
Liquid (in.)	1/4		3/8
Vapor (in.)	3/8		5/8
Drain O.D. / I.D. (in.)	27/32, 5/8		

<sup>1</sup>Nominal capacity is rated 0 ft. above sea level with corresponding refrigerant piping length in accordance with standard length of each outdoor unit and a 0 ft. level difference between outdoor and indoor units. All capacities are net with a combination ratio between 95 – 105%.

Nominal cooling capacity rating obtained with air entering the indoor unit at 80°F dry bulb (DB) and 67°F wet bulb (WB) and outdoor ambient conditions of 95°F dry bulb (DB) and 75°F wet bulb (WB).  
Nominal heating capacity rating obtained with air entering the indoor unit at 70°F dry bulb (DB) and 60°F wet bulb (WB) and outdoor ambient conditions of 47°F dry bulb (DB) and 43°F wet bulb (WB).

<sup>2</sup>This unit comes with a dry helium charge.

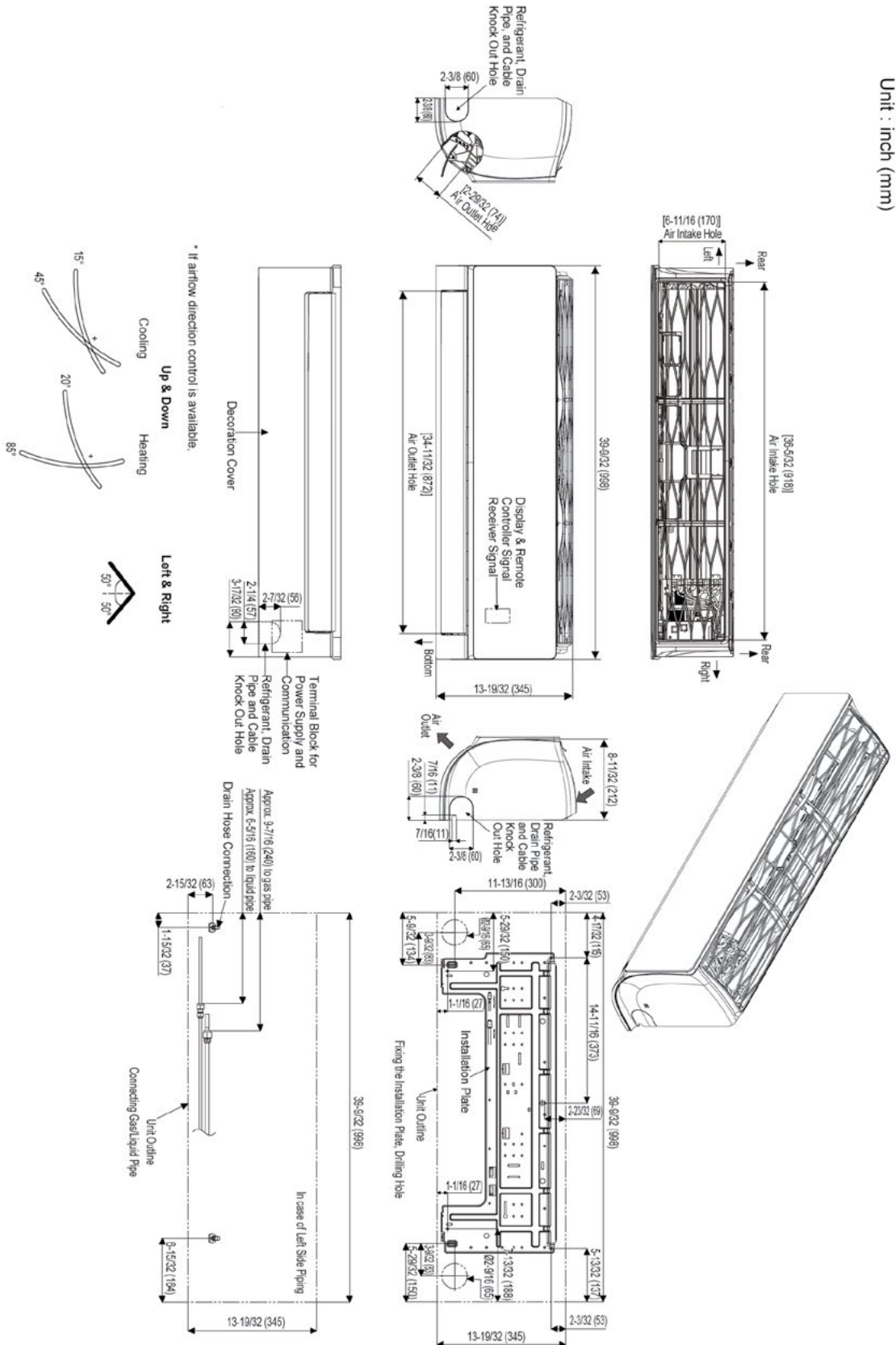
<sup>3</sup>Acceptable operating voltage: 187V-253V.

<sup>4</sup>Sound pressure levels are tested in an anechoic chamber under ISO Standard 3745 and are the same in both cooling and heating mode. These values can increase due to ambient conditions during operation.

<sup>5</sup>The power wiring and the communication wiring from the outdoor unit to the indoor unit, or from the branch distribution unit to the indoor unit is field supplied and must be stranded, shielded or unshielded (if shielded, it must be grounded to the chassis of the outdoor unit only). All wiring must comply with applicable local and national codes.



Figure 3: KNUAK181A Dimensions.



# ART COOL MIRROR INDOOR UNITS

## Cooling Capacity Table

MULTI F  
MULTI F MAX

Table 4: Multi F Art Cool Mirror Indoor Units Cooling Capacity Table.

Model No. / Nominal Capacity of Indoor Unit (Btu/h)	Outdoor Air Temp. (°F DB)	Indoor Air Temp. °F DB / °F WB											
		68 / 57		73 / 61		77 / 64		80 / 67		86 / 72		90 / 75	
		TC	SHC	TC	SHC	TC	SHC	TC	SHC	TC	SHC	TC	SHC
KNUAK091A 9,000	14	8.82	6.04	9.37	6.38	9.92	6.18	10.31	6.31	11.01	6.36	11.56	6.48
	20	8.82	6.09	9.36	6.43	9.91	6.23	10.31	6.36	11.01	6.41	11.55	6.53
	25	8.81	6.13	9.36	6.48	9.90	6.27	10.30	6.41	11.00	6.46	11.54	6.58
	30	8.80	6.18	9.35	6.53	9.90	6.32	10.29	6.46	10.99	6.51	11.54	6.63
	35	8.80	6.23	9.34	6.58	9.89	6.37	10.28	6.50	10.98	6.56	11.53	6.68
	40	8.79	6.28	9.33	6.63	9.88	6.42	10.27	6.55	10.97	6.61	11.52	6.73
	45	8.78	6.32	9.33	6.68	9.87	6.47	10.27	6.60	10.96	6.66	11.51	6.78
	50	8.78	6.37	9.32	6.73	9.87	6.51	10.26	6.65	10.96	6.71	11.50	6.83
	55	8.77	6.42	9.31	6.78	9.86	6.56	10.25	6.70	10.95	6.76	11.49	6.88
	60	8.76	6.46	9.31	6.83	9.85	6.61	10.24	6.75	10.94	6.81	11.48	6.93
	65	8.76	6.51	9.30	6.88	9.84	6.66	10.24	6.80	10.93	6.85	11.47	6.98
	70	8.75	6.56	9.29	6.92	9.84	6.70	10.23	6.85	10.92	6.90	11.47	7.03
	75	8.54	6.45	9.08	6.82	9.62	6.61	10.01	6.75	10.71	6.82	11.25	6.96
	80	8.33	6.34	8.87	6.71	9.41	6.51	9.80	6.66	10.49	6.73	11.03	6.87
	85	8.12	6.22	8.66	6.60	9.20	6.41	9.59	6.56	10.28	6.64	10.82	6.79
	90	7.91	6.10	8.45	6.48	8.99	6.31	9.37	6.46	10.06	6.55	10.60	6.70
	95	7.68	6.04	8.22	6.43	8.75	6.26	<b>9.00</b>	<b>6.32</b>	9.83	6.52	10.36	6.67
	100	7.50	5.88	8.03	6.26	8.57	6.11	8.88	6.22	9.64	6.37	10.17	6.53
	105	7.31	5.72	7.84	6.10	8.38	5.96	8.77	6.12	9.45	6.23	9.99	6.39
	110	7.12	5.52	7.66	5.90	8.19	5.78	8.58	5.94	9.26	6.06	9.80	6.22
115	6.94	5.36	7.47	5.74	8.01	5.63	8.39	5.79	9.08	5.91	9.61	6.08	
118	6.82	5.32	7.36	5.70	7.89	5.60	8.28	5.76	8.96	5.89	9.50	6.06	
122	6.79	5.30	7.32	5.69	7.86	5.59	8.24	5.76	8.93	5.89	9.46	6.06	
KNUAK121A 12,000	14	11.76	8.51	12.49	8.99	13.22	8.70	13.75	8.88	14.69	8.96	15.42	9.13
	20	11.75	8.57	12.48	9.06	13.21	8.77	13.74	8.95	14.67	9.03	15.40	9.20
	25	11.75	8.64	12.48	9.13	13.20	8.84	13.73	9.02	14.66	9.10	15.39	9.27
	30	11.74	8.71	12.47	9.20	13.19	8.90	13.72	9.09	14.65	9.17	15.38	9.34
	35	11.73	8.77	12.46	9.27	13.18	8.97	13.71	9.16	14.64	9.24	15.37	9.41
	40	11.72	8.84	12.45	9.34	13.17	9.04	13.70	9.23	14.63	9.31	15.36	9.48
	45	11.71	8.90	12.44	9.41	13.16	9.11	13.69	9.30	14.62	9.38	15.35	9.55
	50	11.70	8.97	12.43	9.47	13.15	9.17	13.68	9.37	14.61	9.45	15.33	9.62
	55	11.69	9.03	12.42	9.54	13.14	9.24	13.67	9.44	14.60	9.52	15.32	9.70
	60	11.68	9.10	12.41	9.61	13.13	9.31	13.66	9.50	14.59	9.58	15.31	9.77
	65	11.67	9.17	12.40	9.68	13.12	9.38	13.65	9.57	14.57	9.65	15.30	9.84
	70	11.66	9.23	12.39	9.75	13.11	9.44	13.64	9.64	14.56	9.72	15.29	9.91
	75	11.38	9.08	12.11	9.60	12.83	9.31	13.35	9.51	14.27	9.60	15.00	9.79
	80	11.10	8.92	11.82	9.45	12.55	9.17	13.07	9.38	13.99	9.48	14.71	9.68
	85	10.83	8.76	11.54	9.29	12.26	9.03	12.78	9.24	13.70	9.36	14.42	9.56
	90	10.55	8.60	11.26	9.13	11.98	8.88	12.50	9.10	13.42	9.22	14.13	9.43
	95	10.25	8.51	10.96	9.05	11.67	8.82	<b>12.00</b>	<b>8.90</b>	13.10	9.18	13.81	9.39
	100	10.00	8.28	10.71	8.82	11.42	8.61	11.84	8.76	12.85	8.98	13.56	9.20
	105	9.75	8.05	10.46	8.59	11.17	8.40	11.69	8.62	12.60	8.78	13.31	9.01
	110	9.50	7.77	10.21	8.31	10.92	8.14	11.44	8.37	12.35	8.53	13.07	8.76
115	9.25	7.54	9.96	8.08	10.67	7.92	11.19	8.15	12.10	8.33	12.82	8.56	
118	9.10	7.49	9.81	8.03	10.52	7.88	11.04	8.12	11.95	8.30	12.67	8.54	
122	9.05	7.47	9.76	8.01	10.48	7.87	10.99	8.11	11.90	8.29	12.62	8.53	

TC = Total Capacity (kBtu/h).

SHC: Sensible Heat Capacity (kBtu/h).

Nominal capacity as rated 0 ft. above sea level and a 0 ft. level difference between outdoor and indoor units. Corresponding refrigerant piping length is accordance with standard length of each outdoor unit.

Nominal cooling capacity rating obtained with air entering the indoor unit at 80°F dry bulb (DB) and 67°F wet bulb (WB), and outdoor ambient conditions of 95°F dry bulb (DB) and 75°F wet bulb (WB).

The shaded table columns and rows indicate reference data. When operating at this temperature, these values can be different if the system is not running consistently.

Table 5: Multi F Art Cool Mirror Indoor Units Cooling Capacity Table (continued).

Model No. / Nominal Capacity of Indoor Unit (Btu/h)	Outdoor Air Temp. (°F DB)	Indoor Air Temp. °F DB / °F WB											
		68 / 57		73 / 61		77 / 64		80 / 67		86 / 72		90 / 75	
		TC	SHC	TC	SHC	TC	SHC	TC	SHC	TC	SHC	TC	SHC
KNUAK181A 18,000	14	17.65	12.33	18.74	13.02	19.84	12.61	20.63	12.88	22.03	12.98	23.12	13.23
	20	17.63	12.43	18.73	13.13	19.82	12.71	20.61	12.98	22.01	13.09	23.11	13.33
	25	17.62	12.52	18.71	13.23	19.81	12.81	20.60	13.08	22.00	13.19	23.09	13.44
	30	17.60	12.62	18.70	13.33	19.79	12.91	20.58	13.18	21.98	13.29	23.07	13.54
	35	17.59	12.71	18.68	13.43	19.78	13.00	20.57	13.28	21.96	13.39	23.05	13.64
	40	17.58	12.81	18.67	13.53	19.76	13.10	20.55	13.38	21.94	13.49	23.04	13.75
	45	17.56	12.90	18.66	13.63	19.75	13.20	20.53	13.48	21.93	13.59	23.02	13.85
	50	17.55	13.00	18.64	13.73	19.73	13.30	20.52	13.58	21.91	13.69	23.00	13.95
	55	17.54	13.10	18.63	13.83	19.72	13.39	20.50	13.68	21.89	13.79	22.98	14.05
	60	17.52	13.19	18.61	13.93	19.70	13.49	20.49	13.78	21.88	13.89	22.97	14.16
	65	17.51	13.29	18.60	14.03	19.69	13.59	20.47	13.87	21.86	13.99	22.95	14.26
	70	17.50	13.38	18.58	14.13	19.67	13.69	20.46	13.97	21.84	14.09	22.93	14.36
	75	17.08	13.16	18.16	13.92	19.24	13.49	20.03	13.79	21.41	13.92	22.50	14.20
	80	16.66	12.93	17.74	13.70	18.82	13.30	19.60	13.60	20.98	13.75	22.06	14.03
	85	16.24	12.70	17.32	13.47	18.40	13.09	19.17	13.40	20.55	13.56	21.63	13.85
	90	15.82	12.46	16.90	13.23	17.97	12.88	18.75	13.19	20.12	13.37	21.20	13.67
	95	15.37	12.33	16.44	13.12	17.51	12.78	<b>18.00</b>	<b>12.90</b>	19.65	13.30	20.72	13.61
	100	14.99	12.00	16.06	12.78	17.13	12.47	17.77	12.70	19.28	13.01	20.35	13.33
	105	14.62	11.67	15.69	12.45	16.76	12.17	17.53	12.50	18.90	12.73	19.97	13.05
	110	14.24	11.27	15.32	12.05	16.39	11.79	17.16	12.13	18.53	12.36	19.60	12.70
115	13.87	10.93	14.94	11.71	16.01	11.48	16.79	11.82	18.15	12.07	19.22	12.41	
118	13.65	10.85	14.72	11.64	15.79	11.42	16.56	11.77	17.93	12.03	19.00	12.37	
122	13.57	10.83	14.64	11.62	15.71	11.40	16.49	11.75	17.85	12.01	18.92	12.36	

TC = Total Capacity (kBtu/h).

SHC: Sensible Heat Capacity (kBtu/h).

Nominal capacity as rated 0 ft. above sea level and a 0 ft. level difference between outdoor and indoor units. Corresponding refrigerant piping length is accordance with standard length of each outdoor unit.

Nominal cooling capacity rating obtained with air entering the indoor unit at 80°F dry bulb (DB) and 67°F wet bulb (WB), and outdoor ambient conditions of 95°F dry bulb (DB) and 75°F wet bulb (WB).

The shaded table columns and rows indicate reference data. When operating at this temperature, these values can be different if the system is not running consistently.

# ART COOL MIRROR INDOOR UNITS

## Heating Capacity Table

MULTI F  
MULTI F MAX

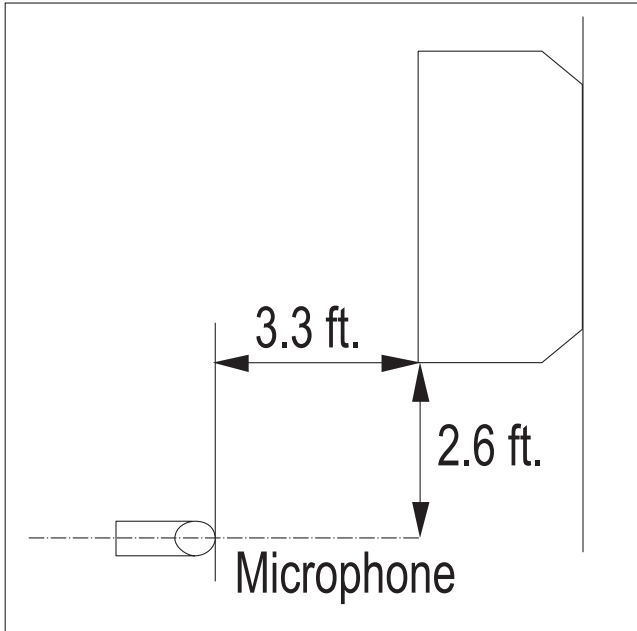
Table 6: Multi F Art Cool Mirror Indoor Units Heating Capacity Table.

Model No. / Nominal Capacity of Indoor Unit (Btu/h)	Outdoor Air Temp.		Indoor Air Temp. °F DB					
	°F DB	°F WB	61	64	68	70	72	75
			TC	TC	TC	TC	TC	TC
KNUAK091A 10,900	0	-0.4	5.61	5.53	5.48	5.45	5.37	5.14
	5	4.5	6.32	6.24	6.18	6.16	6.08	5.85
	10	9	7.03	6.95	6.90	6.88	6.79	6.56
	17	15	7.98	7.90	7.85	<b>7.82</b>	7.75	7.48
	20	19	8.33	8.26	8.21	8.18	8.09	7.82
	25	23	8.93	8.85	8.79	8.77	8.69	8.37
	30	28	9.44	9.36	9.31	9.29	9.20	8.93
	35	32	9.96	9.87	9.82	9.79	9.72	9.47
	40	36	10.42	10.33	10.28	10.25	10.18	9.94
	45	41	10.87	10.80	10.74	10.71	10.64	10.40
	47	43	11.06	10.98	10.93	<b>10.90</b>	10.82	10.59
	50	46	11.24	11.15	11.10	11.08	10.99	10.73
	55	51	11.53	11.46	11.40	11.37	11.30	10.98
	60	56	11.53	11.46	11.40	11.37	11.30	11.03
63	59	11.53	11.46	11.40	11.37	11.30	11.06	
68	64	11.53	11.46	11.40	11.37	11.30	11.11	
KNUAK121A 13,600	0	-0.4	7.00	6.90	6.83	6.80	6.70	6.50
	5	4.5	7.89	7.78	7.71	7.69	7.59	7.40
	10	9	8.78	8.67	8.60	8.58	8.48	8.31
	17	15	9.95	9.86	9.79	<b>9.76</b>	9.67	9.47
	20	19	10.40	10.30	10.23	10.20	10.10	9.90
	25	23	11.14	11.03	10.96	10.95	10.85	10.60
	30	28	11.78	11.67	11.60	11.59	11.49	11.30
	35	32	12.42	12.31	12.24	12.21	12.13	11.99
	40	36	13.00	12.89	12.82	12.79	12.70	12.58
	45	41	13.56	13.46	13.39	13.36	13.28	13.16
	47	43	13.80	13.70	13.63	<b>13.60</b>	13.50	13.40
	50	46	14.02	13.91	13.84	13.82	13.72	13.59
	55	51	14.39	14.29	14.22	14.19	14.10	13.90
	60	56	14.39	14.29	14.22	14.19	14.10	13.96
63	59	14.39	14.29	14.22	14.19	14.10	14.00	
68	64	14.39	14.29	14.22	14.19	14.10	14.06	
KNUAK181A 21,600	0	-0.4	11.11	10.96	10.85	10.80	10.64	10.18
	5	4.5	12.52	12.37	12.26	12.21	12.06	11.58
	10	9	13.93	13.77	13.67	13.61	13.46	12.99
	17	15	15.81	15.65	15.55	<b>15.49</b>	15.34	14.84
	20	19	16.51	16.36	16.25	16.20	16.04	15.49
	25	23	17.69	17.53	17.43	17.37	17.22	16.59
	30	28	18.70	18.55	18.44	18.39	18.24	17.69
	35	32	19.72	19.56	19.46	19.41	19.25	18.79
	40	36	20.63	20.48	20.37	20.32	20.17	19.70
	45	41	21.55	21.39	21.29	21.24	21.08	20.61
	47	43	21.91	21.76	21.65	<b>21.60</b>	21.44	20.98
	50	46	22.26	22.11	22.01	21.95	21.80	21.27
	55	51	22.86	22.70	22.59	22.53	22.38	21.76
	60	56	22.86	22.70	22.59	22.53	22.38	21.85
63	59	22.86	22.70	22.59	22.53	22.38	21.91	
68	64	22.86	22.70	22.59	22.53	22.38	22.02	

TC = Total Capacity (kBtu/h).

Nominal capacity as rated 0 ft. above sea level and a 0 ft. level difference between outdoor and indoor units. Corresponding refrigerant piping length is accordance with standard length of each outdoor unit. Nominal heating capacity rating obtained with air entering the indoor unit at 70°F dry bulb (DB) and 60°F wet bulb (WB), and outdoor ambient conditions of 47°F dry bulb (DB) and 43°F wet bulb (WB).

Figure 4: Sound Pressure Level Measurement Location.

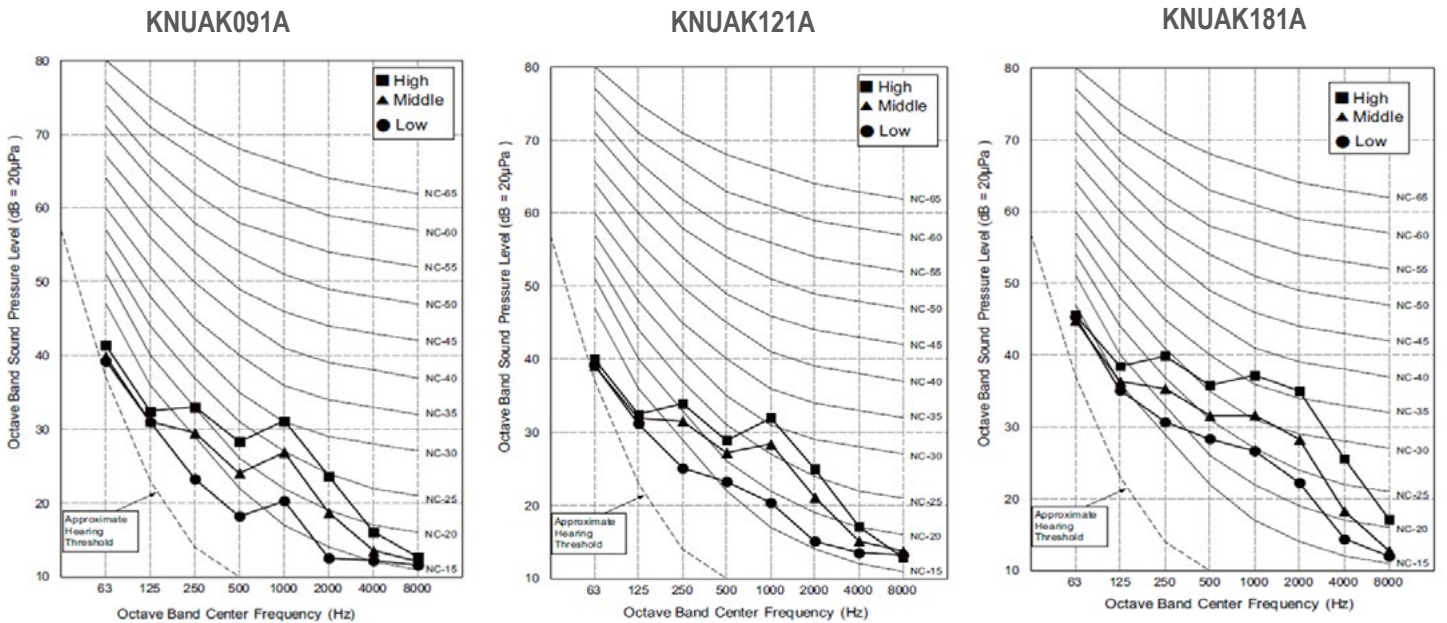


- Measurement taken 2.6' below the bottom of the unit and at a distance of 3.3' from face of unit.
- Measurements taken with no attenuation and units operating at full load normal operating condition.
- Sound level will vary depending on a range of factors such as construction (acoustic absorption coefficient) of particular area in which the equipment is installed.
- Sound power levels are measured in dB(A).
- Tested in anechoic chamber per ISO Standard 3745.

Table 7: Sound Pressure Levels (dB[A]).

Model No.	Sound Pressure Levels (dB[A]) (Cooling and Heating)		
	High Fan Speed	Medium Fan Speed	Low Fan Speed
KNUAK091A	36	32	27
KNUAK121A	38	34	29
KNUAK181A	44	38	34

Figure 5: Sound Pressure Level Diagrams.



# ART COOL MIRROR INDOOR UNITS

## Air Velocity and Temperature Distribution

MULTI F  
MULTI F MAX

Figure 6: KNUAK091A and KNUAK121A Air Velocity and Temperature Distribution Charts.

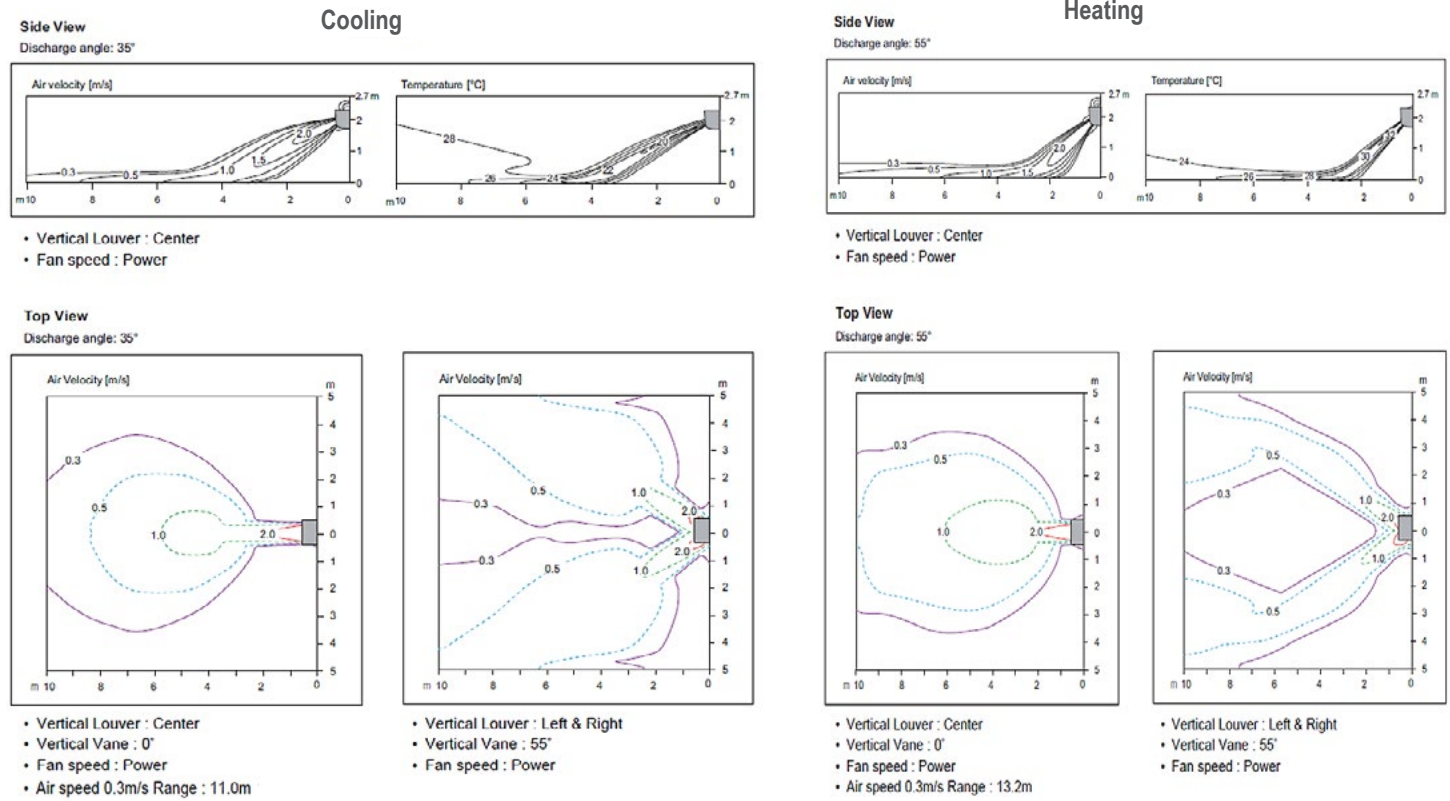


Figure 7: KNUAK181A Air Velocity and Temperature Distribution Charts.

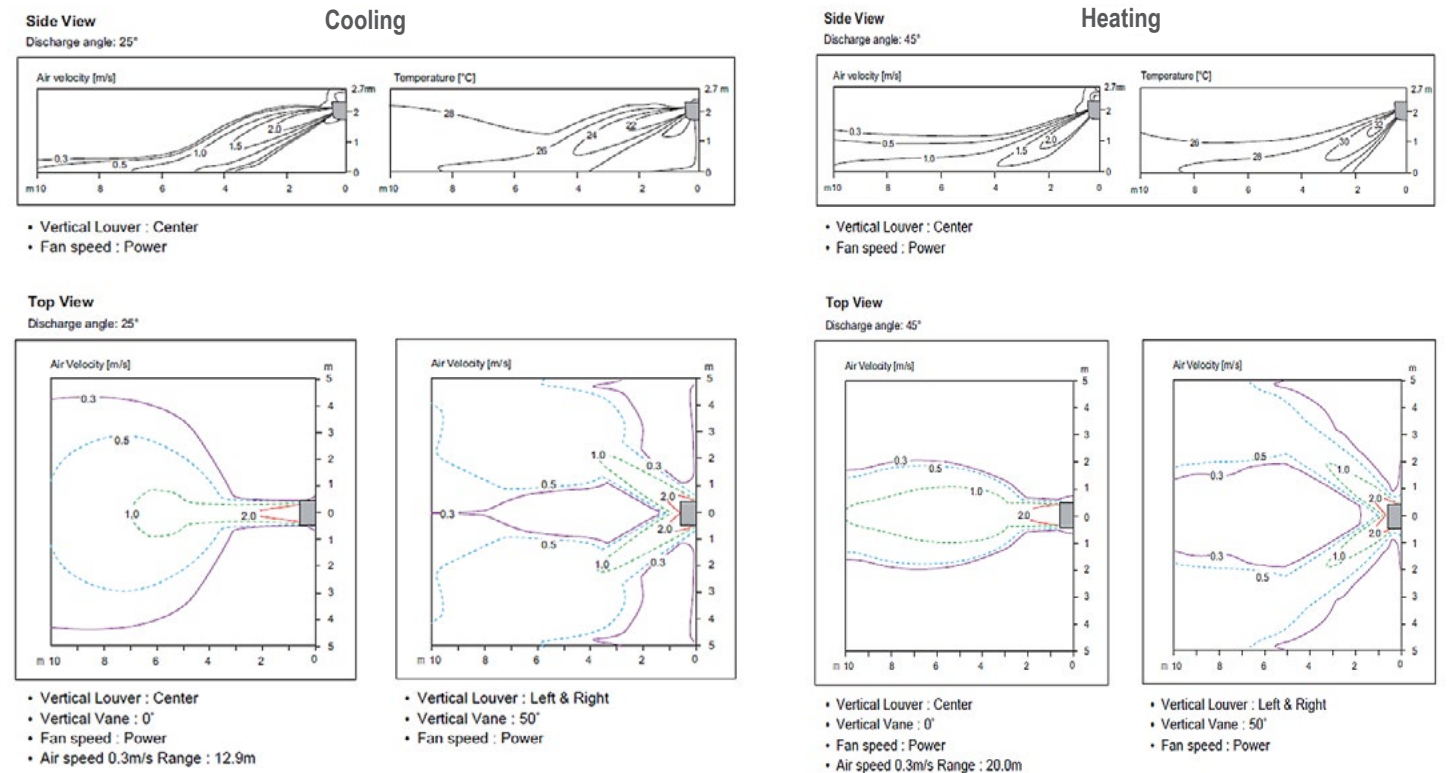


Figure 8: Multi F Art Cool Mirror Indoor Unit Refrigerant Flow Diagram.

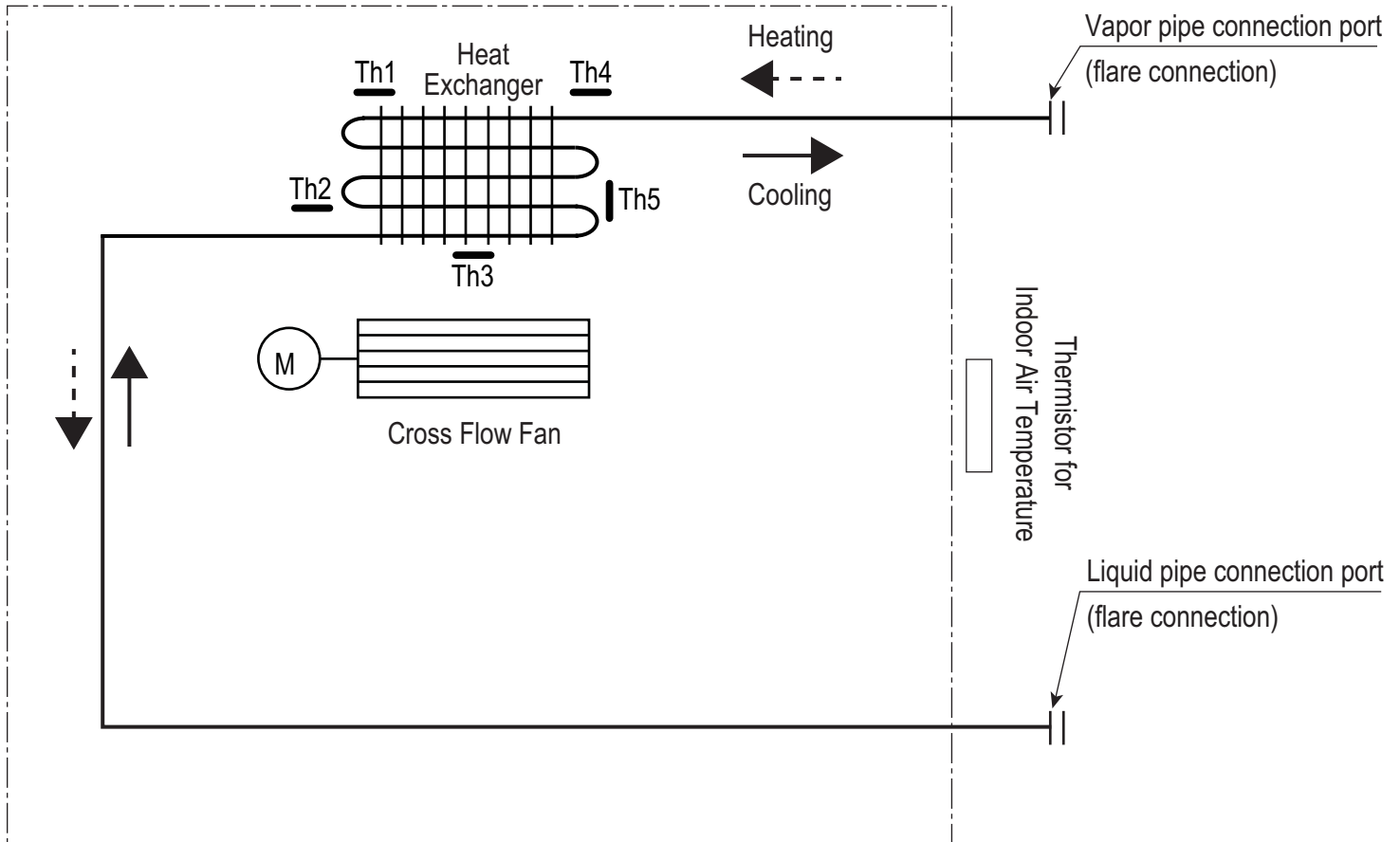


Table 8: Multi F Art Cool Mirror Indoor Unit Refrigerant Pipe Sizes.

Indoor Unit Capacity	Vapor Line Size (in., OD)	Liquid Line Size (in., OD)
9,000 Btu/h	Ø3/8	Ø1/4
12,000 Btu/h		
18,000 Btu/h	Ø1/2	

Table 9: Multi F Art Cool Mirror Indoor Unit Refrigerant Pipe Connections

Indoor Unit Capacity	Vapor Line Connection (in., OD)	Liquid Line Connection (in., OD)
9,000 Btu/h	Ø3/8	Ø1/4
12,000 Btu/h		
18,000 Btu/h	Ø5/8	Ø3/8

Table 10: Multi F Art Cool Mirror Indoor Unit Thermistor Details.

Location	Description (Based on Cooling Mode)	IDU PCB Connector
Th1	Indoor Air Temperature Thermistor	CN-TH1
Th2	Evaporator Inlet Temperature Thermistor	
Th3	Evaporator Middle Temperature Thermistor	CN-TH2
Th4	Evaporator Outlet Temperature Thermistor	
Th5	Water Level Sensor (Optional)	CN-TH3

# ART COOL MIRROR INDOOR UNITS

## Wiring Diagram

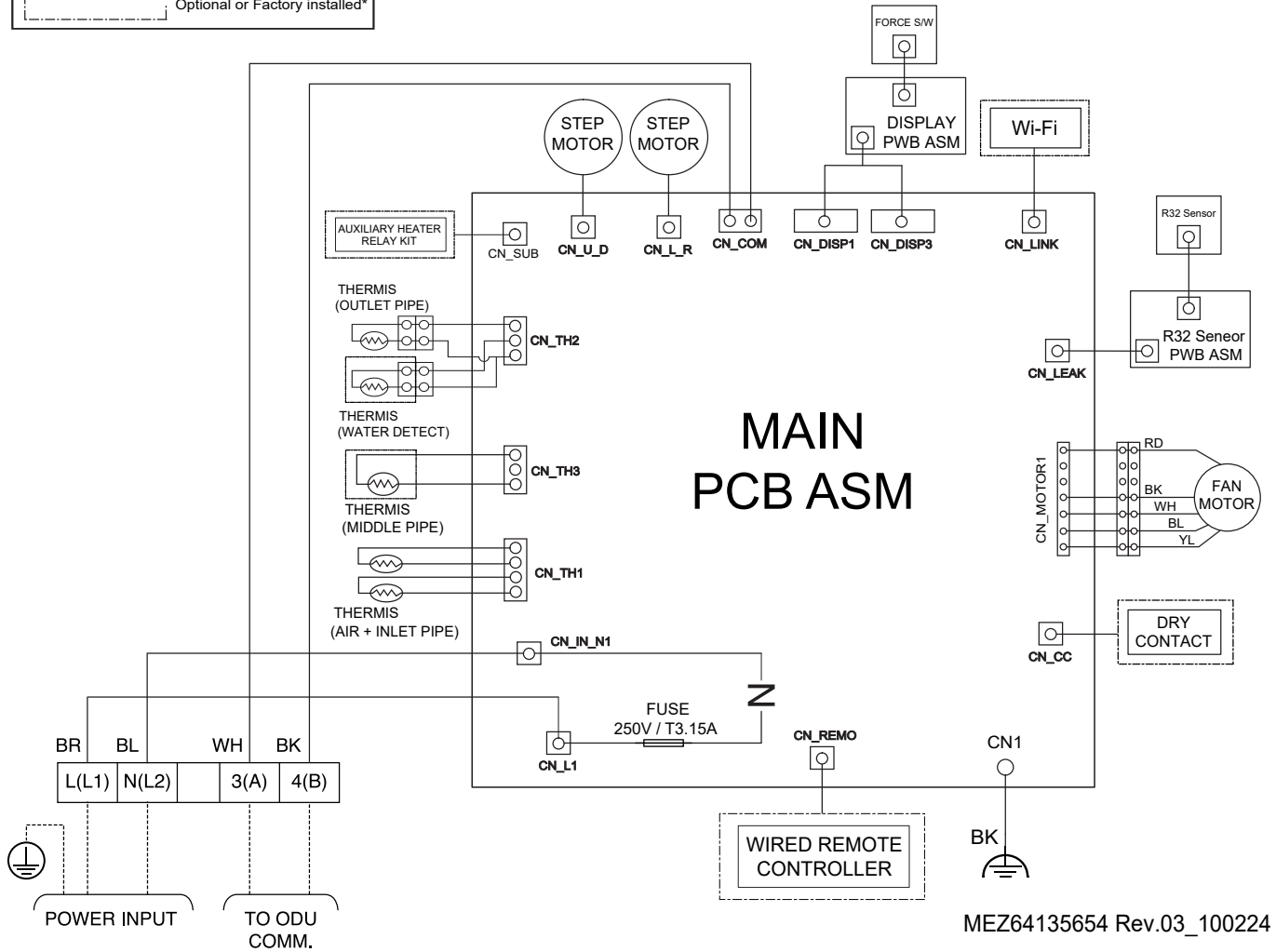
MULTI F  
MULTI F MAX

Figure 9: Multi F Art Cool Mirror KNUAK091A, KNUAK121A, and KNUAK181A Indoor Units Wiring Diagram.

**INFORMATION**

- You need to buy a dedicated circuit separately.
- Factory Wiring
- - - Field Wiring
- - - Optional or Factory installed\*

USE COPPER CONDUCTORS ONLY  
UTILISER DES FILS D'ALIMENTATION EN CUIVRE



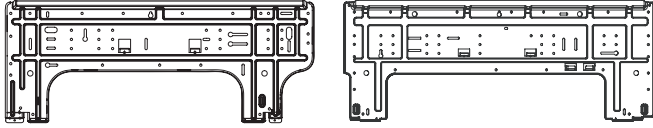
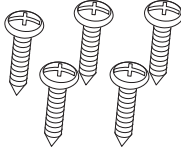
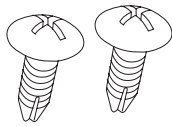

MEZ64135654 Rev.03\_100224

This function can be optional or factory installed depending on the application model.

Multi F and Multi F MAX Indoor Unit Engineering Manual

## Factory Supplied Parts

Table 11: Parts Table.

Part	Quantity	Image
Installation Plate	One (1)	 <p>KNUAK091A and KNUAK121A                      KNUAK181A</p>
Type "A" Screws	Five (5)	
Type "B" Screws (M4 x 12L)	Two (2)	
Wireless Handheld Controller with Holder AKB76044208	One (1)	

## Factory Supplied Materials

- Owner's Manual
- Installation Manual

## Required Tools

- Level
- Screwdriver
- Electric drill
- Hole core drill
- Flaring tool set
- Spanner (Half union)
- Thermometer

### **⚠ WARNING**

Installation work must be performed by trained personnel and in accordance with national wiring standards and all local or other applicable codes. Improper installation can result in fire, electric shock, physical injury, or death.

### **NOTICE**

Read all instructions before installing this product. Become familiar with the unit's components and connections, and the order of installation. Incorrect installation can degrade or prevent proper operation.

# ART COOL MIRROR INDOOR UNITS

## Installation and Best Layout Practices

MULTI F  
MULTI F MAX

### Selecting the Best Installation Location

#### **⚠ DANGER**

To avoid the possibility of fire, ⓧ do not install the unit in an area where combustible gas will generate, flow, stagnate, or leak. Failure to do so will cause serious bodily injury or death. Before beginning installation, read the safety summary at the beginning of this manual.

Select a location for installing the wall-mounted indoor unit (IDU) that meets the following conditions:

- Where there is enough structural strength to bear the weight of the unit
- Where air circulation will not be blocked
- Where noise prevention is taken into consideration
- Ensure there is sufficient space from the ceiling and floor, and sufficient maintenance space
- Locate the indoor unit in a location where it can be easily connected to the outdoor unit/branch distribution unit
- Include space for drainage to ensure condensate flows properly out of the unit when it is in cooling mode
- Use a level indicator to ensure the unit is installed on a level plane

#### **NOTICE**

The unit will be damaged, will malfunction, and/or will not operate as designed if installed in any of the following conditions:

- ⓧ Do not install the unit where it will be subjected to direct thermal radiation from other heat sources.
- ⓧ Do not install the unit in an area where combustible or corrosive gases will generate, flow, stagnate, or leak.
- ⓧ Do not install the unit in a location where acidic solution and spray (sulfur) are often used.
- ⓧ Do not use the unit in environments where oil, steam, or sulfuric gas are present.
- ⓧ Do not install additional ventilation products on the chassis of the unit.
- ⓧ Do not install the unit near high-frequency generator sources.
- ⓧ Do not install the unit near a doorway.

#### **NOTICE**

- ⓧ Indoor units (IDUs) must not be placed in an environment where the IDUs will be exposed to harmful volatile organic compounds (VOCs) or in environments where there is improper air make up or supply or inadequate ventilation. If there are concerns about VOCs in the environment where the IDUs are installed, proper air make up or supply and/or adequate ventilation must be provided. Additionally, in buildings where IDUs will be exposed to VOCs, consider a third party factory-applied epoxy coating to the fan coils for each IDU where the entire coil is dipped, not sprayed.
- If the unit is installed near a body of water, the installation parts are at risk of corroding. Appropriate anti-corrosion methods must be taken for the unit and all installation parts.

#### **Installing in an Area Exposed to Unconditioned Air**

In some installation applications, areas (floors, walls) in some rooms will be exposed to unconditioned air (room will be above or next to an unheated garage or storeroom). To countermeasure:

- Verify that carpet is or will be installed (carpet will increase the temperature by three degrees).
- Add insulation between the floor joists.
- Install radiant heat or another type of heating system to the floor.

## Required Clearances

Figure 10 shows required clearance distances around a typical installed wall-mounted unit.

## Mounting the Installation Plate

The mounting wall must be strong and solid enough to protect the unit from vibration.

- Mount the installation plate on the wall using the Type "A" screws. If mounting the unit on concrete, consider using anchor bolts.
- Always mount the installation plate horizontally. Measure the wall and mark the centerline using thread and a level.

## Preparing for Installation

Prepare the refrigerant piping and drain hose (indoor unit piping) for installation through the wall: press on the top of the tubing clamp and slowly guide the piping / hose down (depending on installation requirements, then to the left or right). Relock the tubing clamp after the piping / hose are released.

### NOTICE

⊘ Do not bend the piping / drain hose from side to side; it will damage the components.

Figure 10: Minimum Clearance Requirements.

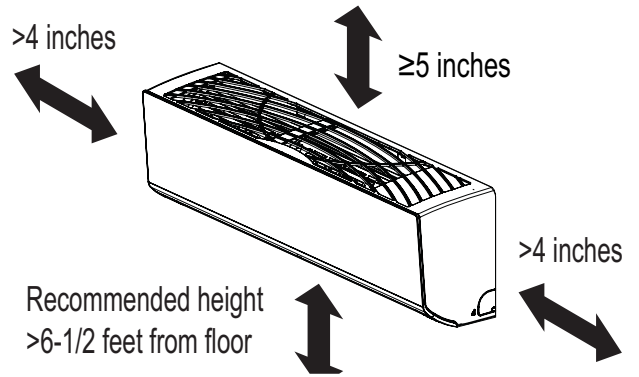


Figure 13: Preparing for Installation.

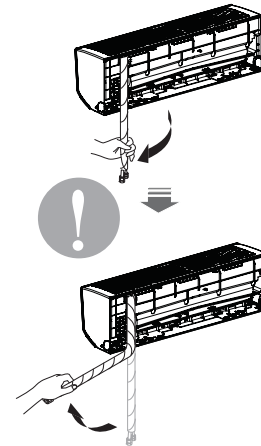


Figure 11: Installation Plate for KNUAK091A and KNUAK121A Units.

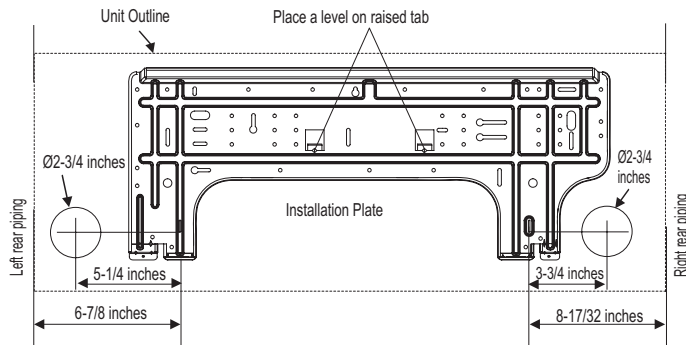
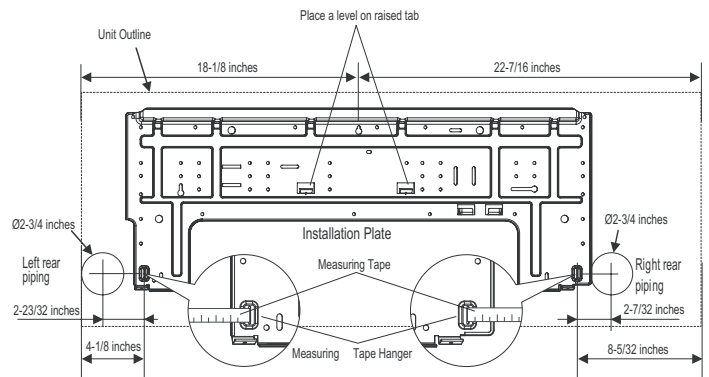


Figure 12: Installation Plate for KNUAK181A Units.



# ART COOL MIRROR INDOOR UNITS

## Installation and Best Layout Practices

MULTI F  
MULTI F MAX

### Drilling Piping Hole in the Wall

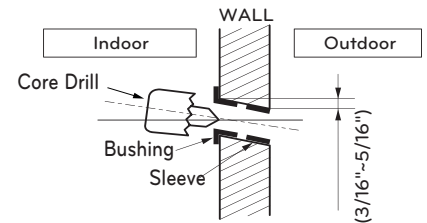
#### ⚠ WARNING

Use caution when drilling holes through walls. Drilling into power wiring in the wall can cause serious bodily injury or death.

Follow the left or right piping clearance recommendations.

1. Using a 2-5/8 (ø 65mm) inch hole core drill bit, drill a hole at either the right or left side of the wall mounting. The hole must slant 3/16" to 5/16" from level (upward on the indoor unit side and downward on the outdoor unit side).
2. Finish off the newly drilled hole as shown with bushing and sleeve covering. Sleeve and bushing prevents damage to the tubing/bundling of the piping.

Figure 20: Drilling Piping Hole



### Hanging the Indoor Unit Chassis

1. Attach the three (3) hooks on the top of the indoor unit to the top edge of the installation plate. Verify the hooks are properly attached to the installation plate by gently shaking the indoor unit from side to side.
2. Unlock the tubing clamp from the indoor unit frame. For easier access between the bottom of the indoor unit and the wall, prop the clamp between the indoor unit frame and installation plate.
3. Remove the screw covers at the bottom of the indoor unit, unscrew the two (2) screws, remove the frame cover, remove the piping connection cover, and position the piping for installation (down, back, left, or right).

Figure 14: Locking the Indoor Unit onto the Installation Plate.

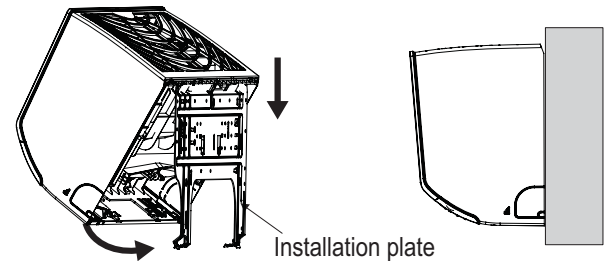


Figure 15: Accessing the Back of the Indoor Unit.

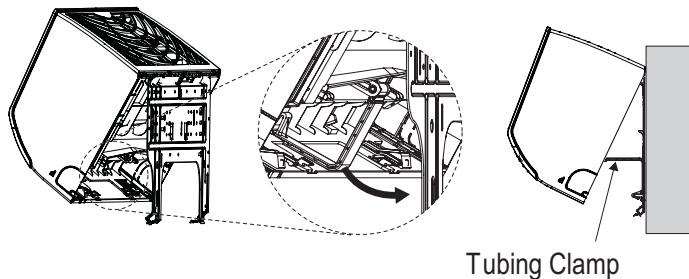


Figure 16: Removing the Frame Cover.

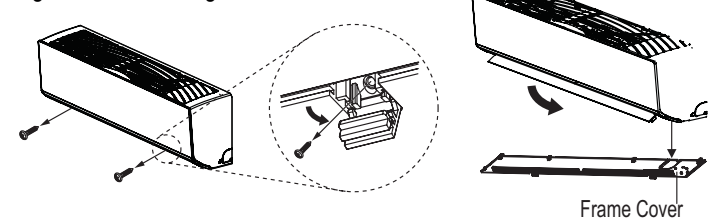


Figure 17: Exterior Back View of Indoor Unit.

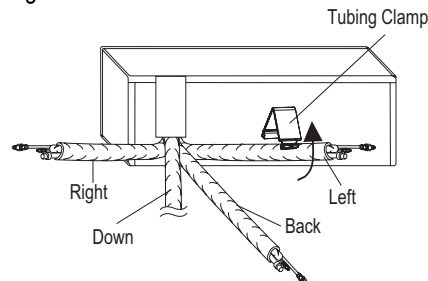


Figure 18: Piping Installed to the Left.

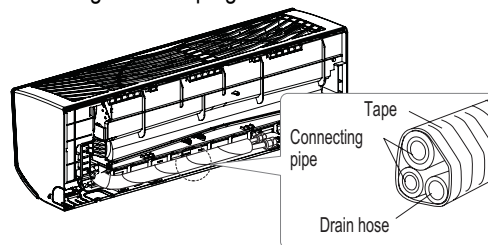
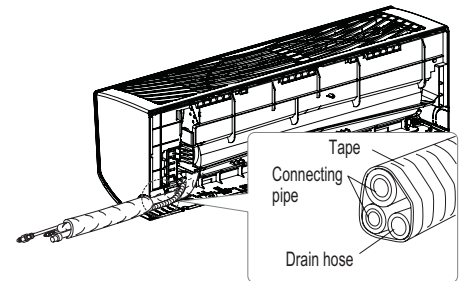


Figure 19: Piping Installed to the Right.



### Power Wiring / Communications Cable Guidelines

- Follow manufacturer's circuit diagrams in the technical manuals.
- Confirm power source specifications.
- Confirm that the electrical capacity is sufficient.
- Starting current must be maintained  $\pm 10$  percent of the rated current marked on the outdoor unit name plate.
- Confirm cable thickness specifications.
- It is required that a circuit breaker is installed, especially if conditions could become wet or moist.
- Include a disconnect in the power wiring system, add an air gap contact separation of at least 1/8 inch in each active (phase) conductor.

### ⚠ WARNING

• Loose wiring will cause unit to malfunction, overheat, and catch fire, resulting in severe injury or death.

### NOTICE

- Terminal screws will become loose during transport. Properly tighten the terminal connections during installation.
- A voltage drop will cause the following problems:
- Magnetic switch vibration, fuse breaks, or disturbance to the normal function of an overload protection device.
  - Compressor will not receive the proper starting current.

### Connecting the Power Wiring and Communications Cable

1. Insert the power wiring/communications cable from the outdoor unit or branch distribution unit (Multi F MAX systems only) through the bottom of the indoor unit.
2. Connect each wire to its appropriate terminal on the indoor unit control board. Verify that the color and terminal numbers from the outdoor unit or branch distribution unit (Multi F MAX systems only) wiring match the color and terminal numbers on the indoor unit.
3. Secure the power wiring/communications cable with the cable restraint.

Figure 21: Connecting the Power Wiring / Communications Cable.

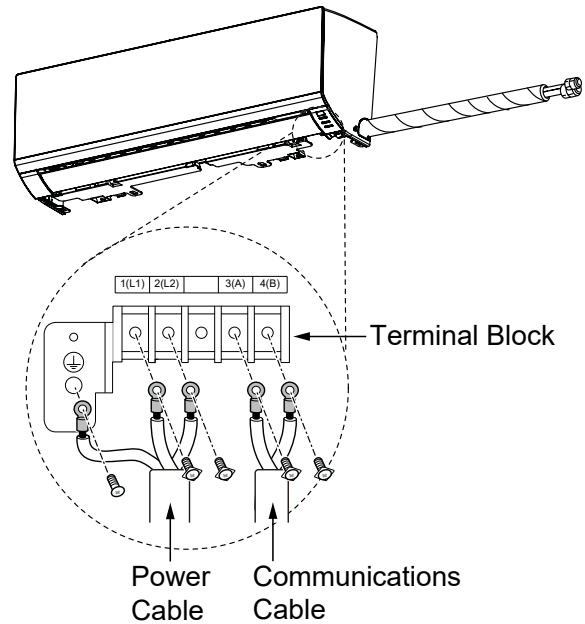
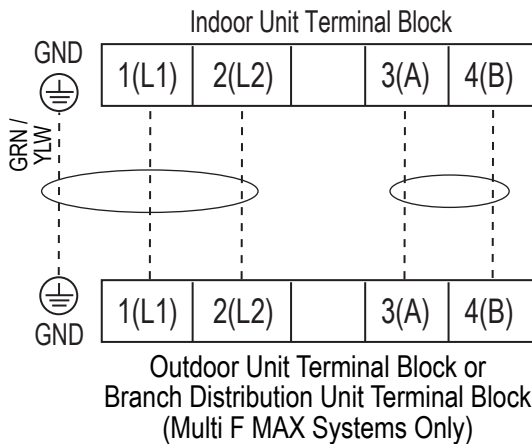


Figure 22: Simplified View of Art Cool Mirror Indoor Unit to Outdoor Unit / Branch Distribution Unit Terminal Connections.



# ART COOL MIRROR INDOOR UNITS

## Installation and Best Layout Practices

MULTI F  
MULTI F MAX

### Wireless Handheld Controller

Figure 23: AKB76044208 Wireless Controller.

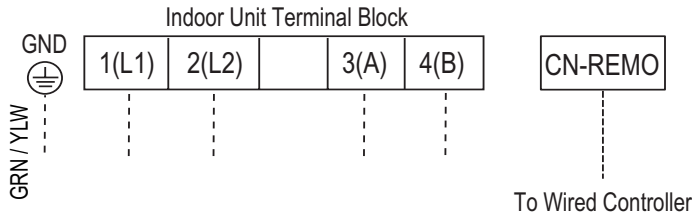
Table 12: AKB76044208 Wireless Controller Functions.



Image	Description
	<b>Power</b> Turns the appliance on or off. <b>Connecting to LG ThinQ</b> Press and hold the Power button for about 3 seconds to prepare for connecting appliance and Wi-Fi.
	<b>Mode</b> Selects the desired operating mode. • Each press changes the mode in this order: Cooling ~ Auto ~ Dehumidification ~ Heating ~ Fan 7 & 8 Press and hold the Mode button for about 3 seconds to change units between 7 and 8
	<b>AI/AEC</b> Selects AI Smart Care or Active Energy Control to decrease the power input. <b>NOTE</b> • When connected to the Multi Outdoor unit, Active Energy Control function may not be supported.
	<b>Temperature J , K</b> Adjusts the desired room temperature.
	<b>Fan Speed ~ , !</b> Adjusts the fan speed.
	<b>y (Up-Down Swing)</b> Adjusts the airflow direction up and down. <b>Cmft Air</b> Press and hold the y button for about 3 seconds to adjust the airflow direction. This will help minimize direct contact with airflow.
	<b>A (Left-Right Swing)</b> Adjusts the airflow direction left and right.
	<b>Jet</b> Changes the room temperature quickly and operates at maximum fan speed. <b>Exit</b> When entering the settings, press and hold the Jet button for about 3 seconds to return the previous setting.
	<b>Function</b> Selects the desired function. <b>NOTE</b> • When connected to the Multi Outdoor unit, Low Ambient Heating function may not be supported.
	<b>H (Sleep)</b> Automatically turns the appliance off at a desired time. Use it before sleeping. <b>Night Mode</b> Press and hold the H button for about 3 seconds to turn off the display and the beep sound.
	<b>a Reset</b> Resets the wireless remote control setting.

### Wired Controller Connections

Figure 24: Wired Controller Connection on the Indoor Unit Terminal Block.

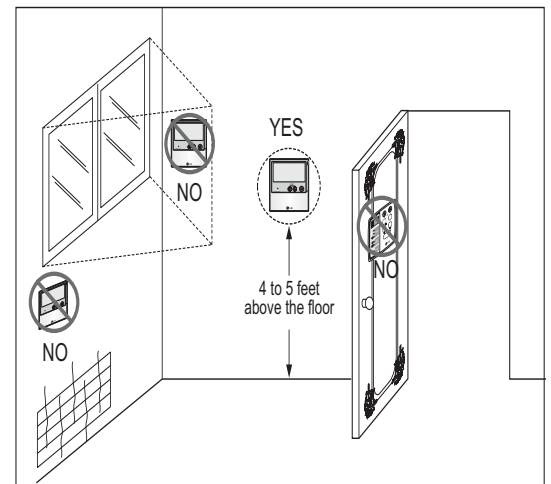


### Wired Controller Placement

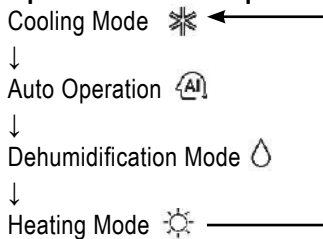
Wired controllers include a sensor to detect room temperature. To maintain comfort levels in the conditioned space, the wired controller must be installed in a location away from direct sunlight, high humidity, and where it could be directly exposed to cold air. Controller must be installed four (4) to five (5) feet above the floor where its LED display can be read easily, in an area with good air circulation, and where it can detect an average room temperature.

- ⊘ Do not install the wired controller near or in:
  - Drafts or dead spots behind doors and in corners
  - Hot or cold air from ducts
  - Radiant heat from the sun or appliances
  - Concealed pipes and chimneys
  - An area where temperatures are uncontrolled, such as an outside wall

Figure 25: Proper Location for the Wired Controller.



### Operation Mode Sequence



# ART COOL MIRROR INDOOR UNITS

## Installation and Best Layout Practices

MULTI F  
MULTI F MAX

### Hanging the Wired Controller

1. The controller wiring/cable can be installed in one of three directions: top, back, or on the right side. If top or right side installation is desired, remove cable guide grooves on the controller, and then position wiring/cable on applicable side.
2. Choose and mark the area of installation, and then screw the wall plate into place (using the provided parts). Install the controller wall plate to fit the electrical box if one is present. Ensure that no gaps exist between the wall plate and the wall itself.
3. Arrange wiring/cables so as not to interfere with the controller circuitry. Position the wired controller on the wall plate. Snap into place by pressing the bottom part of the wired controller onto the wall plate. Make sure that no gaps exist between the wired controller and the wall plate on all sides.
4. To remove wired controller from the wall plate, insert a screwdriver into the two holes at the bottom. Twist screwdriver to release controller. ⚠ Do not damage the controller components when removing.

Figure 26: Removing the Cable Guide Grooves.

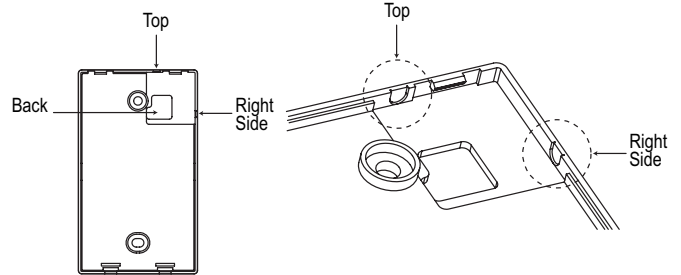


Figure 27: Attaching the Wall Plate.

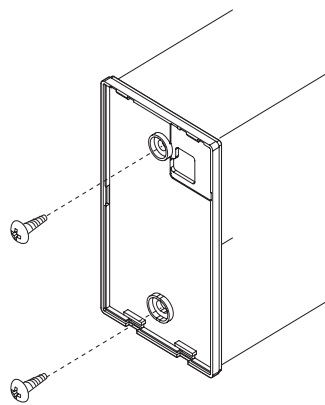
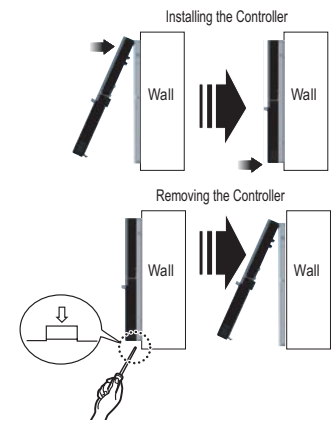


Figure 28: Installing/Removing the Controller.



### Assigning the Thermistor for Temperature Detection

Each indoor unit includes a return air thermistor assigned to sense the temperature. If a wired controller is installed, there is a choice of sensing temperature with either the indoor unit return air thermistor or the thermistor in the wired controller. It is also an option to set both thermistors to sense temperature so that indoor unit bases its operation on the first thermistor to reach the designated temperature differential. For applicable indoor units, an optional Remote Temperature Sensor can be used in lieu of the return air thermistor—either alone or in conjunction with a wired controller thermistor as previously described.

### Finalizing Indoor Unit Installation

1. Move the tubing clamp to its original position.
2. Ensure the three (3) hooks are properly attached to the installation plate by gently shaking the indoor unit from side to side.
3. Press the bottom left and right sides of the indoor unit against the installation plate until the hooks click firmly into their slots.
4. Using two (2) Type “C” screws, secure the bottom of the indoor unit to the installation plate.
5. Remove the two (2) tabs from the filter.
6. Replace the frame cover.

Figure 29: Attach Bottom of Indoor Unit to Installation Plate.

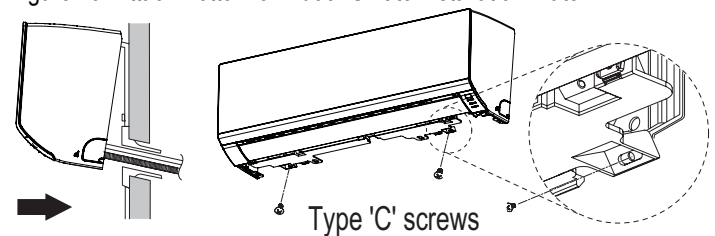
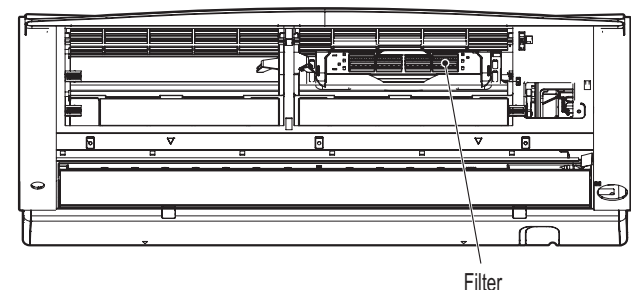


Figure 30: Removing the Filter Tabs.



# HIGH EFFICIENCY WALL-MOUNTED INDOOR UNIT DATA

**Mechanical Specifications on page 30**

**General Data / Specifications on page 31**

**Dimensions on page 32**

**Cooling Capacity Table on page 34**

**Heating Capacity Table on page 37**

**Acoustic Data on page 39**

**Air Velocity and Temperature Distribution on page 41**

**Refrigerant Flow Diagram on page 43**

**Wiring Diagram on page 44**

**Factory Supplied Parts and Materials on page 45**

**Installation and Best Layout Practices on page 46**

# HIGH EFFICIENCY WALL-MOUNTED INDOOR UNITS

MULTI F  
MULTI F MAX

## Mechanical Specifications and Features

### High Efficiency Wall-Mounted Indoor Units

#### General

All LG indoor units are factory assembled, wired, piped, and provided with a control circuit board, fan, and motor. High Efficiency Wall-Mounted units have a sound rating no higher than 46 dB(A) as tested per KSA0701 ISO Standard 3745.

#### Coil

Indoor unit coils are comprised of a minimum of two rows of aluminum fins mechanically bonded to copper tubing. The coils are pressure tested at the factory. Each unit is provided with a factory installed condensate drain pan below the coil.

#### Refrigerant System

The system is designed for use with R32 refrigerant. The refrigeration circuit is pressure-tested at the factory and shipped with a holding charge of helium gas. Refrigerant pipe connections are 45° flare. All refrigerant lines from the outdoor unit to the indoor units must be field insulated.

#### Electrical

The indoor units require 208–230Vac/60Hz/1Φ power with voltage variance of no more than ±10%.

#### Casing

The units mount on a vertical surface. They are shipped with a separate back plate that secures the unit to the wall, protruding no more than nine (9) inches. Refrigerant piping can be installed in one (1) of four (4) different directions.

#### Finish

The High Efficiency Wall-Mounted unit has a curved architectural panel with a pearl white finish. Unit casing has a pearl white or dark gray finish and is manufactured of heavy-duty acrylonitrile butadiene styrene (ABS) and high impact polystyrene (HIPS) plastic.

#### Fan Assembly and Control

The unit has a single, direct-drive, crossflow fan made of high strength ABS plastic. The fan motor is brushless digitally controlled (BLDC) with permanently lubricated and sealed ball bearings. The fan / motor assembly is mounted on vibration attenuating rubber grommets. Fan speed is controlled using a microprocessor-based direct digitally controlled algorithm that provides pre-programmed, field-selectable fixed or auto fan speeds in the Heating and Cooling modes. For High Efficiency Wall-Mounted units, the indoor fan has Low, Med, High, Jet Cool, and Auto settings for Cooling mode; and has Low, Med, High, Jet Heat, and Auto settings for Heating mode. The Auto setting adjusts the fan speed based on the difference between the controller setpoint and space temperature.

#### Air Filter

The return air inlet has a factory-supplied primary removable, washable filter. The unit is also equipped with a secondary 3M Micro Dust filter. Filters are accessed from the front of the unit without the use of tools.

### Features

- Inverter (Variable speed fan)
- Comfort Air
- 3M filter
- Jet cool/Jet Heat
- Group control
- Self-cleaning indoor coil
- Auto operation
- Auto restart operation
- Built-in wi-fi
- Dehumidifying function
- Self-diagnostic function
- Wireless LCD remote control included

Figure 31: Multi F High Efficiency Wall-Mounted Indoor Unit.



#### Airflow Guide Vanes

A factory-installed motorized guide vane controls the direction of airflow from side to side. A motorized louver provides an automatic change in airflow by directing the air up and down for uniform air distribution.

#### Microprocessor Control

The indoor unit has an integrated control panel to communicate with the outdoor unit. All unit operation parameters are stored in non-volatile memory resident on the unit microprocessor. The microprocessor controls space temperature through using the value provided by the temperature sensor within the indoor unit. The microprocessor control will activate indoor unit operation when the indoor room temperature falls below or rises above a setpoint temperature, at which point, a signal is sent to the outdoor unit to begin the appropriate mode. The microprocessor also provides self-diagnostics and auto restart functions. A field-supplied three-wire power cable (3 x 14 AWG) and two-wire communications cable (2 x 18 AWG) must be installed to connect the indoor unit(s) to the outdoor unit.

#### R32 Refrigerant Leak Detector

The indoor unit has a built-in R32 refrigerant leak detection sensor designed to communicate with release mitigation devices and third party alarms, and transmit a system error code upon detection of a refrigerant leak or sensor failure / expiration.

#### Shut-off Valve

LG single-port shutoff valve (PRHPZ010A; sold separately) is available as an accessory.

#### Controls

The indoor unit casing has a factory-standard, integral infrared sensor to communicate with the supplied LG wireless handheld remote controller. An optional LG supplied wired controller is available as an additional accessory. Communication between the indoor units and the outdoor unit is accomplished through 18 AWG, two-core, stranded and shielded communication cable. The indoor unit has built-in wi-fi and can be controlled with LG's SmartThinQ app on a smart device. A field-supplied wi-fi network and smart device are required. The SmartThinQ app is free and is available for Android and iOS smart devices.

#### Condensate

The unit is designed for gravity draining of condensate and includes a flexible drain hose capable of installation in one of two directions.

Table 13: Multi F High Efficiency Wall-Mounted Indoor Unit General Data.

Model Name	KNMAB071A	KNUAB091A	KNUAB121A	KNMAB151A	KNUAB181A	KNMAB241A
Nominal Cooling Capacity (Btu/h) <sup>1</sup>	7,000	9,000	12,000	14,300	18,000	24,000
Nominal Heating Capacity (Btu/h) <sup>1</sup>	8,100	10,900	13,600	15,600	21,600	25,600
<b>Operating Range</b>						
Cooling (°F WB)	57-77					
Heating (°F DB)	59-81					
<b>Fan</b>						
Type	Cross Flow					
Motor Output (W) x Qty.	30 x 1			58 x 1		
Motor/Drive	Brushless Digitally Controlled / Direct					
Airflow Rate CFM (H/M/L)	254 / 204 / 148	268 / 218 / 169	282 / 233 / 177	314 / 268 / 184	558 / 438 / 353	597 / 452 / 367
<b>Unit Data</b>						
Refrigerant Type <sup>2</sup>	R32					
Refrigerant Control	EEV					
Power Supply V, Ø, Hz <sup>3</sup>	208-230, 1, 60					
Rated Amps (A)	0.4					
Sound Pressure Level dB(A) (H/M/L) <sup>4</sup>	35 / 31 / 26	36 / 32 / 27	38 / 34 / 29	42 / 38 / 32	44 / 38 / 34	46 / 41 / 36
Dimensions (W x H x D, in.)	32-15/16 x 12-1/8 x 7-7/16				39-9/32 x 13-19/32 x 8-9/32	
Net Unit Weight (lbs.)	19.73			26.0	26.5	
Shipping Weight (lbs.)	22.7			31.8	30	
Power Wiring Cable (No. x AWG) <sup>5</sup>	3 x 14					
Communications Wiring Cable (No. x AWG) <sup>5</sup>	2 x 18					
Heat Exchanger (Row x Column x Fin / inch) x Number	(2 x 23 x 22) x 1				(2 x 16 x 20) x 1	
Dehumidification Rate (pts/hr)	2.65	2.7	2.75	2.8	5.5	5.55
<b>Pipe Size</b>						
Liquid (in.)	1/4					
Vapor (in.)	3/8			1/2		
<b>Connection Size</b>						
Liquid (in.)	1/4			3/8	1/4	
Vapor (in.)	3/8			5/8	1/2	
Drain O.D. / I.D. (in.)	27/32, 5/8					

<sup>1</sup>Nominal capacity is rated 0 ft. above sea level with corresponding refrigerant piping length in accordance with standard length of each outdoor unit and a 0 ft. level difference between outdoor and indoor units. All capacities are net with a combination ratio between 95 – 105%.

Nominal cooling capacity rating obtained with air entering the indoor unit at 80°F dry bulb (DB) and 67°F wet bulb (WB) and outdoor ambient conditions of 95°F dry bulb (DB) and 75°F wet bulb (WB).  
Nominal heating capacity rating obtained with air entering the indoor unit at 70°F dry bulb (DB) and 60°F wet bulb (WB) and outdoor ambient conditions of 47°F dry bulb (DB) and 43°F wet bulb (WB).

<sup>2</sup>This unit comes with a dry helium charge.

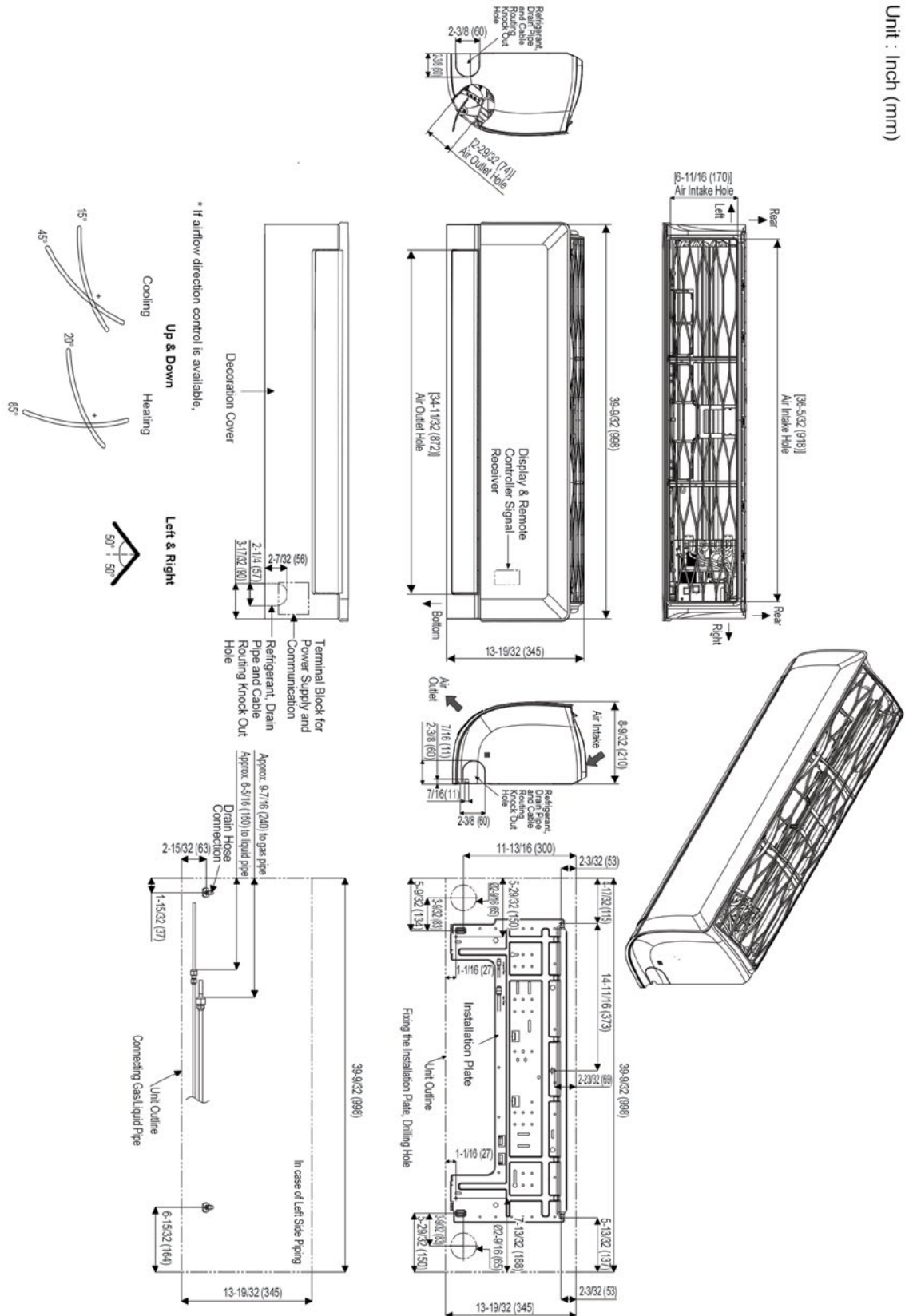
<sup>3</sup>Acceptable operating voltage: 187V-253V.

<sup>4</sup>Sound pressure levels are tested in an anechoic chamber under ISO Standard 3745 and are the same in both cooling and heating mode. These values can increase due to ambient conditions during operation.

<sup>5</sup>The power wiring and the communication wiring from the outdoor unit to the indoor unit, or from the branch distribution unit to the indoor unit is field supplied and must be stranded, shielded or unshielded (if shielded, it must be grounded to the chassis of the outdoor unit only). All wiring must comply with applicable local and national codes.



Figure 33: KNUAB181A and KNMAB241A Dimensions.



# HIGH EFFICIENCY WALL-MOUNTED INDOOR UNITS

## Cooling Capacity Table

MULTI F  
MULTI F MAX

Table 14: Multi F High Efficiency Wall-Mounted Indoor Units Cooling Capacity Table.

Model No. / Nominal Capacity of Indoor Unit (Btu/h)	Outdoor Air Temp. (°F DB)	Indoor Air Temp. °F DB / °F WB											
		68 / 57		73 / 61		77 / 64		80 / 67		86 / 72		90 / 75	
		TC	SHC	TC	SHC	TC	SHC	TC	SHC	TC	SHC	TC	SHC
KNMAB071A 7,000	14	6.86	4.68	7.29	4.95	7.71	4.79	8.02	4.89	8.57	4.93	8.99	5.03
	20	6.86	4.72	7.28	4.99	7.71	4.83	8.02	4.93	8.56	4.97	8.99	5.06
	25	6.85	4.76	7.28	5.02	7.70	4.86	8.01	4.97	8.55	5.01	8.98	5.10
	30	6.85	4.79	7.27	5.06	7.70	4.90	8.00	5.01	8.55	5.05	8.97	5.14
	35	6.84	4.83	7.27	5.10	7.69	4.94	8.00	5.04	8.54	5.09	8.97	5.18
	40	6.84	4.87	7.26	5.14	7.68	4.98	7.99	5.08	8.53	5.12	8.96	5.22
	45	6.83	4.90	7.25	5.18	7.68	5.01	7.99	5.12	8.53	5.16	8.95	5.26
	50	6.83	4.94	7.25	5.22	7.67	5.05	7.98	5.16	8.52	5.20	8.94	5.30
	55	6.82	4.97	7.24	5.25	7.67	5.09	7.97	5.19	8.51	5.24	8.94	5.34
	60	6.81	5.01	7.24	5.29	7.66	5.12	7.97	5.23	8.51	5.28	8.93	5.38
	65	6.81	5.05	7.23	5.33	7.66	5.16	7.96	5.27	8.50	5.31	8.92	5.42
	70	6.80	5.08	7.23	5.37	7.65	5.20	7.95	5.31	8.49	5.35	8.92	5.45
	75	6.64	5.00	7.06	5.29	7.48	5.13	7.79	5.24	8.33	5.29	8.75	5.39
	80	6.48	4.91	6.90	5.20	7.32	5.05	7.62	5.16	8.16	5.22	8.58	5.33
	85	6.31	4.82	6.73	5.12	7.15	4.97	7.46	5.09	7.99	5.15	8.41	5.26
	90	6.15	4.73	6.57	5.03	6.99	4.89	7.29	5.01	7.83	5.08	8.24	5.19
	95	5.98	4.68	6.39	4.98	6.81	4.85	<b>7.00</b>	<b>4.90</b>	7.64	5.05	8.06	5.17
	100	5.83	4.56	6.25	4.86	6.66	4.74	6.91	4.82	7.50	4.94	7.91	5.06
	105	5.69	4.43	6.10	4.73	6.52	4.62	6.82	4.75	7.35	4.83	7.77	4.96
	110	5.54	4.28	5.96	4.58	6.37	4.48	6.67	4.61	7.21	4.70	7.62	4.82
115	5.39	4.15	5.81	4.45	6.23	4.36	6.53	4.49	7.06	4.58	7.48	4.71	
118	5.31	4.12	5.72	4.42	6.14	4.34	6.44	4.47	6.97	4.57	7.39	4.70	
122	5.28	4.11	5.69	4.41	6.11	4.33	6.41	4.46	6.94	4.56	7.36	4.70	
KNUAB091A 9,000	14	8.82	6.04	9.37	6.38	9.92	6.18	10.31	6.31	11.01	6.36	11.56	6.48
	20	8.82	6.09	9.36	6.43	9.91	6.23	10.31	6.36	11.01	6.41	11.55	6.53
	25	8.81	6.13	9.36	6.48	9.90	6.27	10.30	6.41	11.00	6.46	11.54	6.58
	30	8.80	6.18	9.35	6.53	9.90	6.32	10.29	6.46	10.99	6.51	11.54	6.63
	35	8.80	6.23	9.34	6.58	9.89	6.37	10.28	6.50	10.98	6.56	11.53	6.68
	40	8.79	6.28	9.33	6.63	9.88	6.42	10.27	6.55	10.97	6.61	11.52	6.73
	45	8.78	6.32	9.33	6.68	9.87	6.47	10.27	6.60	10.96	6.66	11.51	6.78
	50	8.78	6.37	9.32	6.73	9.87	6.51	10.26	6.65	10.96	6.71	11.50	6.83
	55	8.77	6.42	9.31	6.78	9.86	6.56	10.25	6.70	10.95	6.76	11.49	6.88
	60	8.76	6.46	9.31	6.83	9.85	6.61	10.24	6.75	10.94	6.81	11.48	6.93
	65	8.76	6.51	9.30	6.88	9.84	6.66	10.24	6.80	10.93	6.85	11.47	6.98
	70	8.75	6.56	9.29	6.92	9.84	6.70	10.23	6.85	10.92	6.90	11.47	7.03
	75	8.54	6.45	9.08	6.82	9.62	6.61	10.01	6.75	10.71	6.82	11.25	6.96
	80	8.33	6.34	8.87	6.71	9.41	6.51	9.80	6.66	10.49	6.73	11.03	6.87
	85	8.12	6.22	8.66	6.60	9.20	6.41	9.59	6.56	10.28	6.64	10.82	6.79
	90	7.91	6.10	8.45	6.48	8.99	6.31	9.37	6.46	10.06	6.55	10.60	6.70
	95	7.68	6.04	8.22	6.43	8.75	6.26	<b>9.00</b>	<b>6.32</b>	9.83	6.52	10.36	6.67
	100	7.50	5.88	8.03	6.26	8.57	6.11	8.88	6.22	9.64	6.37	10.17	6.53
	105	7.31	5.72	7.84	6.10	8.38	5.96	8.77	6.12	9.45	6.23	9.99	6.39
	110	7.12	5.52	7.66	5.90	8.19	5.78	8.58	5.94	9.26	6.06	9.80	6.22
115	6.94	5.36	7.47	5.74	8.01	5.63	8.39	5.79	9.08	5.91	9.61	6.08	
118	6.82	5.32	7.36	5.70	7.89	5.60	8.28	5.76	8.96	5.89	9.50	6.06	
122	6.79	5.30	7.32	5.69	7.86	5.59	8.24	5.76	8.93	5.89	9.46	6.06	

TC = Total Capacity (kBtu/h).

SHC: Sensible Heat Capacity (kBtu/h).

Nominal capacity as rated 0 ft. above sea level and a 0 ft. level difference between outdoor and indoor units. Corresponding refrigerant piping length is accordance with standard length of each outdoor unit.

Nominal cooling capacity rating obtained with air entering the indoor unit at 80°F dry bulb (DB) and 67°F wet bulb (WB), and outdoor ambient conditions of 95°F dry bulb (DB) and 75°F wet bulb (WB).

The shaded table columns and rows indicate reference data. When operating at this temperature, these values can be different if the system is not running consistently.

# HIGH EFFICIENCY WALL-MOUNTED INDOOR UNITS

Cooling Capacity Table

Table 15: Multi F High Efficiency Wall-Mounted Indoor Units Cooling Capacity Table (continued).

Model No. / Nominal Capacity of Indoor Unit (Btu/h)	Outdoor Air Temp. (°F DB)	Indoor Air Temp. °F DB / °F WB											
		68 / 57		73 / 61		77 / 64		80 / 67		86 / 72		90 / 75	
		TC	SHC	TC	SHC	TC	SHC	TC	SHC	TC	SHC	TC	SHC
KNUAB121A 12,000	14	11.76	8.51	12.49	8.99	13.22	8.70	13.75	8.88	14.69	8.96	15.42	9.13
	20	11.75	8.57	12.48	9.06	13.21	8.77	13.74	8.95	14.67	9.03	15.40	9.20
	25	11.75	8.64	12.48	9.13	13.20	8.84	13.73	9.02	14.66	9.10	15.39	9.27
	30	11.74	8.71	12.47	9.20	13.19	8.90	13.72	9.09	14.65	9.17	15.38	9.34
	35	11.73	8.77	12.46	9.27	13.18	8.97	13.71	9.16	14.64	9.24	15.37	9.41
	40	11.72	8.84	12.45	9.34	13.17	9.04	13.70	9.23	14.63	9.31	15.36	9.48
	45	11.71	8.90	12.44	9.41	13.16	9.11	13.69	9.30	14.62	9.38	15.35	9.55
	50	11.70	8.97	12.43	9.47	13.15	9.17	13.68	9.37	14.61	9.45	15.33	9.62
	55	11.69	9.03	12.42	9.54	13.14	9.24	13.67	9.44	14.60	9.52	15.32	9.70
	60	11.68	9.10	12.41	9.61	13.13	9.31	13.66	9.50	14.59	9.58	15.31	9.77
	65	11.67	9.17	12.40	9.68	13.12	9.38	13.65	9.57	14.57	9.65	15.30	9.84
	70	11.66	9.23	12.39	9.75	13.11	9.44	13.64	9.64	14.56	9.72	15.29	9.91
	75	11.38	9.08	12.11	9.60	12.83	9.31	13.35	9.51	14.27	9.60	15.00	9.79
	80	11.10	8.92	11.82	9.45	12.55	9.17	13.07	9.38	13.99	9.48	14.71	9.68
	85	10.83	8.76	11.54	9.29	12.26	9.03	12.78	9.24	13.70	9.36	14.42	9.56
	90	10.55	8.60	11.26	9.13	11.98	8.88	12.50	9.10	13.42	9.22	14.13	9.43
	95	10.25	8.51	10.96	9.05	11.67	8.82	12.00	8.90	13.10	9.18	13.81	9.39
	100	10.00	8.28	10.71	8.82	11.42	8.61	11.84	8.76	12.85	8.98	13.56	9.20
105	9.75	8.05	10.46	8.59	11.17	8.40	11.69	8.62	12.60	8.78	13.31	9.01	
110	9.50	7.77	10.21	8.31	10.92	8.14	11.44	8.37	12.35	8.53	13.07	8.76	
115	9.25	7.54	9.96	8.08	10.67	7.92	11.19	8.15	12.10	8.33	12.82	8.56	
118	9.10	7.49	9.81	8.03	10.52	7.88	11.04	8.12	11.95	8.30	12.67	8.54	
122	9.05	7.47	9.76	8.01	10.48	7.87	10.99	8.11	11.90	8.29	12.62	8.53	
KNMAB151A 14,300	14	14.02	10.23	14.89	10.80	15.76	10.46	16.39	10.68	17.50	10.77	18.37	10.97
	20	14.01	10.31	14.88	10.89	15.75	10.54	16.38	10.76	17.49	10.85	18.36	11.06
	25	14.00	10.39	14.87	10.97	15.74	10.62	16.36	10.85	17.47	10.94	18.34	11.15
	30	13.99	10.47	14.85	11.06	15.72	10.70	16.35	10.93	17.46	11.02	18.33	11.23
	35	13.98	10.55	14.84	11.14	15.71	10.79	16.34	11.01	17.45	11.11	18.32	11.32
	40	13.96	10.62	14.83	11.22	15.70	10.87	16.33	11.10	17.43	11.19	18.30	11.40
	45	13.95	10.70	14.82	11.31	15.69	10.95	16.31	11.18	17.42	11.27	18.29	11.49
	50	13.94	10.78	14.81	11.39	15.68	11.03	16.30	11.26	17.41	11.36	18.27	11.57
	55	13.93	10.86	14.80	11.47	15.66	11.11	16.29	11.34	17.39	11.44	18.26	11.66
	60	13.92	10.94	14.79	11.56	15.65	11.19	16.28	11.43	17.38	11.52	18.25	11.74
	65	13.91	11.02	14.78	11.64	15.64	11.27	16.26	11.51	17.37	11.61	18.23	11.83
	70	13.90	11.10	14.76	11.72	15.63	11.35	16.25	11.59	17.35	11.69	18.22	11.91
	75	13.57	10.92	14.43	11.55	15.29	11.19	15.91	11.44	17.01	11.55	17.87	11.78
	80	13.23	10.73	14.09	11.36	14.95	11.03	15.57	11.28	16.67	11.40	17.53	11.64
	85	12.90	10.53	13.76	11.17	14.61	10.86	15.23	11.11	16.33	11.25	17.18	11.49
	90	12.57	10.33	13.42	10.98	14.28	10.68	14.90	10.94	15.99	11.09	16.84	11.34
	95	12.21	10.23	13.06	10.88	13.91	10.60	14.30	10.70	15.61	11.03	16.46	11.29
	100	11.91	9.95	12.76	10.60	13.61	10.35	14.11	10.53	15.31	10.79	16.16	11.06
105	11.61	9.68	12.46	10.33	13.32	10.09	13.93	10.37	15.02	10.56	15.87	10.83	
110	11.32	9.35	12.17	10.00	13.02	9.78	13.63	10.06	14.72	10.26	15.57	10.53	
115	11.02	9.07	11.87	9.71	12.72	9.52	13.33	9.80	14.42	10.01	15.27	10.29	
118	10.84	9.00	11.69	9.66	12.54	9.48	13.16	9.76	14.24	9.98	15.09	10.26	
122	10.78	8.98	11.63	9.64	12.48	9.46	13.10	9.74	14.18	9.97	15.03	10.25	

TC = Total Capacity (kBtu/h).

SHC: Sensible Heat Capacity (kBtu/h).

Nominal capacity as rated 0 ft. above sea level and a 0 ft. level difference between outdoor and indoor units. Corresponding refrigerant piping length is accordance with standard length of each outdoor unit.

Nominal cooling capacity rating obtained with air entering the indoor unit at 80°F dry bulb (DB) and 67°F wet bulb (WB), and outdoor ambient conditions of 95°F dry bulb (DB) and 75°F wet bulb (WB).

The shaded table columns and rows indicate reference data. When operating at this temperature, these values can be different if the system is not running consistently.

High Efficiency Wall-Mounted

# HIGH EFFICIENCY WALL-MOUNTED INDOOR UNITS

MULTI F  
MULTI F MAX

## Cooling Capacity Table

Table 16: Multi F High Efficiency Wall-Mounted Indoor Units Cooling Capacity Table (continued).

Model No. / Nominal Capacity of Indoor Unit (Btu/h)	Outdoor Air Temp. (°F DB)	Indoor Air Temp. °F DB / °F WB											
		68 / 57		73 / 61		77 / 64		80 / 67		86 / 72		90 / 75	
		TC	SHC	TC	SHC	TC	SHC	TC	SHC	TC	SHC	TC	SHC
KNUAB181A 18,000	14	17.65	12.33	18.74	13.02	19.84	12.61	20.63	12.88	22.03	12.98	23.12	13.23
	20	17.63	12.43	18.73	13.13	19.82	12.71	20.61	12.98	22.01	13.09	23.11	13.33
	25	17.62	12.52	18.71	13.23	19.81	12.81	20.60	13.08	22.00	13.19	23.09	13.44
	30	17.60	12.62	18.70	13.33	19.79	12.91	20.58	13.18	21.98	13.29	23.07	13.54
	35	17.59	12.71	18.68	13.43	19.78	13.00	20.57	13.28	21.96	13.39	23.05	13.64
	40	17.58	12.81	18.67	13.53	19.76	13.10	20.55	13.38	21.94	13.49	23.04	13.75
	45	17.56	12.90	18.66	13.63	19.75	13.20	20.53	13.48	21.93	13.59	23.02	13.85
	50	17.55	13.00	18.64	13.73	19.73	13.30	20.52	13.58	21.91	13.69	23.00	13.95
	55	17.54	13.10	18.63	13.83	19.72	13.39	20.50	13.68	21.89	13.79	22.98	14.05
	60	17.52	13.19	18.61	13.93	19.70	13.49	20.49	13.78	21.88	13.89	22.97	14.16
	65	17.51	13.29	18.60	14.03	19.69	13.59	20.47	13.87	21.86	13.99	22.95	14.26
	70	17.50	13.38	18.58	14.13	19.67	13.69	20.46	13.97	21.84	14.09	22.93	14.36
	75	17.08	13.16	18.16	13.92	19.24	13.49	20.03	13.79	21.41	13.92	22.50	14.20
	80	16.66	12.93	17.74	13.70	18.82	13.30	19.60	13.60	20.98	13.75	22.06	14.03
	85	16.24	12.70	17.32	13.47	18.40	13.09	19.17	13.40	20.55	13.56	21.63	13.85
	90	15.82	12.46	16.90	13.23	17.97	12.88	18.75	13.19	20.12	13.37	21.20	13.67
	95	15.37	12.33	16.44	13.12	17.51	12.78	18.00	12.90	19.65	13.30	20.72	13.61
	100	14.99	12.00	16.06	12.78	17.13	12.47	17.77	12.70	19.28	13.01	20.35	13.33
105	14.62	11.67	15.69	12.45	16.76	12.17	17.53	12.50	18.90	12.73	19.97	13.05	
110	14.24	11.27	15.32	12.05	16.39	11.79	17.16	12.13	18.53	12.36	19.60	12.70	
115	13.87	10.93	14.94	11.71	16.01	11.48	16.79	11.82	18.15	12.07	19.22	12.41	
118	13.65	10.85	14.72	11.64	15.79	11.42	16.56	11.77	17.93	12.03	19.00	12.37	
122	13.57	10.83	14.64	11.62	15.71	11.40	16.49	11.75	17.85	12.01	18.92	12.36	
KNMAB241A 24,000	14	23.53	16.82	24.99	17.77	26.45	17.21	27.50	17.57	29.37	17.72	30.83	18.05
	20	23.51	16.95	24.97	17.91	26.43	17.34	27.48	17.70	29.35	17.85	30.81	18.19
	25	23.49	17.08	24.95	18.05	26.41	17.47	27.46	17.84	29.33	17.99	30.79	18.33
	30	23.47	17.21	24.93	18.19	26.39	17.61	27.44	17.98	29.30	18.13	30.76	18.47
	35	23.46	17.35	24.91	18.32	26.37	17.74	27.42	18.12	29.28	18.27	30.74	18.61
	40	23.44	17.48	24.89	18.46	26.35	17.88	27.40	18.25	29.26	18.41	30.72	18.75
	45	23.42	17.61	24.87	18.60	26.33	18.01	27.38	18.39	29.24	18.54	30.69	18.89
	50	23.40	17.74	24.85	18.74	26.31	18.14	27.36	18.52	29.21	18.68	30.67	19.03
	55	23.38	17.87	24.84	18.87	26.29	18.27	27.34	18.66	29.19	18.82	30.64	19.17
	60	23.37	18.00	24.82	19.01	26.27	18.41	27.32	18.79	29.17	18.95	30.62	19.31
	65	23.35	18.13	24.80	19.15	26.25	18.54	27.29	18.93	29.15	19.09	30.60	19.45
	70	23.33	18.26	24.78	19.28	26.23	18.67	27.27	19.07	29.13	19.23	30.57	19.59
	75	22.77	17.95	24.21	18.99	25.66	18.41	26.70	18.81	28.55	18.99	29.99	19.37
	80	22.21	17.65	23.65	18.69	25.09	18.14	26.13	18.55	27.97	18.75	29.42	19.14
	85	21.65	17.33	23.09	18.38	24.53	17.86	25.57	18.28	27.40	18.50	28.84	18.90
	90	21.09	17.00	22.53	18.06	23.96	17.57	25.00	18.00	26.83	18.24	28.27	18.65
	95	20.49	16.82	21.92	17.89	23.35	17.44	24.00	17.60	26.20	18.14	27.63	18.57
	100	19.99	16.37	21.42	17.44	22.85	17.02	23.69	17.33	25.70	17.75	27.13	18.19
105	19.49	15.92	20.92	16.99	22.35	16.60	23.38	17.06	25.20	17.36	26.63	17.81	
110	18.99	15.38	20.42	16.44	21.85	16.09	22.88	16.55	24.70	16.87	26.13	17.32	
115	18.49	14.91	19.92	15.98	21.35	15.66	22.38	16.12	24.20	16.47	25.63	16.93	
118	18.19	14.81	19.62	15.88	21.05	15.59	22.08	16.05	23.90	16.41	25.33	16.88	
122	18.10	14.77	19.52	15.85	20.95	15.56	21.98	16.03	23.81	16.39	25.23	16.86	

TC = Total Capacity (kBtu/h).

SHC: Sensible Heat Capacity (kBtu/h).

Nominal capacity as rated 0 ft. above sea level and a 0 ft. level difference between outdoor and indoor units. Corresponding refrigerant piping length is accordance with standard length of each outdoor unit.

Nominal cooling capacity rating obtained with air entering the indoor unit at 80°F dry bulb (DB) and 67°F wet bulb (WB), and outdoor ambient conditions of 95°F dry bulb (DB) and 75°F wet bulb (WB).

The shaded table columns and rows indicate reference data. When operating at this temperature, these values can be different if the system is not running consistently.

# HIGH EFFICIENCY WALL-MOUNTED INDOOR UNITS

Heating Capacity Table

Table 17: Multi F High Efficiency Wall-Mounted Indoor Units Heating Capacity Table.

Model No. / Nominal Capacity of Indoor Unit (Btu/h)	Outdoor Air Temp.		Indoor Air Temp. °F DB					
	°F DB	°F WB	61	64	68	70	72	75
			TC	TC	TC	TC	TC	TC
KNMAB071A 8,100	0	-0.4	4.17	4.11	4.07	4.05	3.99	3.82
	5	4.5	4.70	4.64	4.60	4.58	4.52	4.34
	10	9	5.22	5.17	5.13	5.11	5.05	4.87
	17	15	5.93	5.87	5.83	<b>5.81</b>	5.75	5.56
	20	19	6.19	6.13	6.09	6.08	6.02	5.81
	25	23	6.63	6.57	6.53	6.52	6.46	6.22
	30	28	7.01	6.96	6.92	6.90	6.84	6.63
	35	32	7.40	7.34	7.30	7.28	7.22	7.04
	40	36	7.74	7.68	7.64	7.62	7.56	7.39
	45	41	8.08	8.02	7.98	7.96	7.90	7.73
	47	43	8.22	8.16	8.12	<b>8.10</b>	8.04	7.87
	50	46	8.35	8.29	8.25	8.23	8.17	7.98
	55	51	8.57	8.51	8.47	8.45	8.39	8.16
	60	56	8.57	8.51	8.47	8.45	8.39	8.20
	63	59	8.57	8.51	8.47	8.45	8.39	8.22
	68	64	8.57	8.51	8.47	8.45	8.39	8.25
KNUAB091A 10,900	0	-0.4	5.61	5.53	5.48	5.45	5.37	5.14
	5	4.5	6.32	6.24	6.18	6.16	6.08	5.85
	10	9	7.03	6.95	6.90	6.88	6.79	6.56
	17	15	7.98	7.90	7.85	<b>7.82</b>	7.75	7.48
	20	19	8.33	8.26	8.21	8.18	8.09	7.82
	25	23	8.93	8.85	8.79	8.77	8.69	8.37
	30	28	9.44	9.36	9.31	9.29	9.20	8.93
	35	32	9.96	9.87	9.82	9.79	9.72	9.47
	40	36	10.42	10.33	10.28	10.25	10.18	9.94
	45	41	10.87	10.80	10.74	10.71	10.64	10.40
	47	43	11.06	10.98	10.93	<b>10.90</b>	10.82	10.59
	50	46	11.24	11.15	11.10	11.08	10.99	10.73
	55	51	11.53	11.46	11.40	11.37	11.30	10.98
	60	56	11.53	11.46	11.40	11.37	11.30	11.03
	63	59	11.53	11.46	11.40	11.37	11.30	11.06
	68	64	11.53	11.46	11.40	11.37	11.30	11.11
KNUAB121A 13,600	0	-0.4	7.00	6.90	6.83	6.80	6.70	6.50
	5	4.5	7.89	7.78	7.71	7.69	7.59	7.40
	10	9	8.78	8.67	8.60	8.58	8.48	8.31
	17	15	9.95	9.86	9.79	<b>9.76</b>	9.67	9.47
	20	19	10.40	10.30	10.23	10.20	10.10	9.90
	25	23	11.14	11.03	10.96	10.95	10.85	10.60
	30	28	11.78	11.67	11.60	11.59	11.49	11.30
	35	32	12.42	12.31	12.24	12.21	12.13	11.99
	40	36	13.00	12.89	12.82	12.79	12.70	12.58
	45	41	13.56	13.46	13.39	13.36	13.28	13.16
	47	43	13.80	13.70	13.63	<b>13.60</b>	13.50	13.40
	50	46	14.02	13.91	13.84	13.82	13.72	13.59
	55	51	14.39	14.29	14.22	14.19	14.10	13.90
	60	56	14.39	14.29	14.22	14.19	14.10	13.96
	63	59	14.39	14.29	14.22	14.19	14.10	14.00
	68	64	14.39	14.29	14.22	14.19	14.10	14.06

TC = Total Capacity (kBtu/h).

Nominal capacity as rated 0 ft. above sea level and a 0 ft. level difference between outdoor and indoor units. Corresponding refrigerant piping length is accordance with standard length of each outdoor unit. Nominal heating capacity rating obtained with air entering the indoor unit at 70°F dry bulb (DB) and 60°F wet bulb (WB), and outdoor ambient conditions of 47°F dry bulb (DB) and 43°F wet bulb (WB).

High Efficiency Wall-Mounted

# HIGH EFFICIENCY WALL-MOUNTED INDOOR UNITS

MULTI F  
MULTI F MAX

## Heating Capacity Table

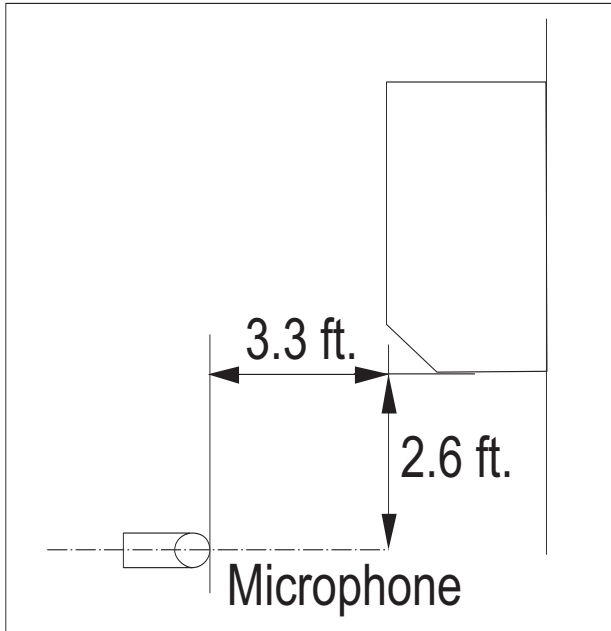
Table 18: Multi F High Efficiency Wall-Mounted Indoor Units Heating Capacity Table.

Model No. / Nominal Capacity of Indoor Unit (Btu/h)	Outdoor Air Temp.		Indoor Air Temp. °F DB					
	°F DB	°F WB	61	64	68	70	72	75
			TC	TC	TC	TC	TC	TC
KNMAB151A 15,600	0	-0.4	8.03	7.91	7.84	7.80	7.69	7.35
	5	4.5	9.05	8.93	8.86	8.82	8.71	8.37
	10	9	10.06	9.95	9.87	9.83	9.72	9.38
	17	15	11.42	11.31	11.23	<b>11.19</b>	11.08	10.71
	20	19	12.03	11.81	11.73	11.70	11.59	11.19
	25	23	12.77	12.66	12.58	12.55	12.43	11.98
	30	28	13.51	13.40	13.32	13.28	13.17	12.77
	35	32	14.25	14.13	14.06	14.02	13.91	13.57
	40	36	14.90	14.79	14.71	14.67	14.56	14.23
	45	41	15.56	15.45	15.37	15.34	15.22	14.88
	47	43	15.83	15.71	15.64	<b>15.60</b>	15.49	15.15
	50	46	16.08	15.97	15.89	15.86	15.74	15.36
	55	51	16.51	16.39	16.32	16.28	16.17	15.71
	60	56	16.51	16.39	16.32	16.28	16.17	15.78
	63	59	16.51	16.39	16.32	16.28	16.17	15.83
	68	64	16.51	16.39	16.32	16.28	16.17	15.89
KNUAB181A 21,600	0	-0.4	11.11	10.96	10.85	10.80	10.64	10.18
	5	4.5	12.52	12.37	12.26	12.21	12.06	11.58
	10	9	13.93	13.77	13.67	13.61	13.46	12.99
	17	15	15.81	15.65	15.55	<b>15.49</b>	15.34	14.84
	20	19	16.51	16.36	16.25	16.20	16.04	15.49
	25	23	17.69	17.53	17.43	17.37	17.22	16.59
	30	28	18.70	18.55	18.44	18.39	18.24	17.69
	35	32	19.72	19.56	19.46	19.41	19.25	18.79
	40	36	20.63	20.48	20.37	20.32	20.17	19.70
	45	41	21.55	21.39	21.29	21.24	21.08	20.61
	47	43	21.91	21.76	21.65	<b>21.60</b>	21.44	20.98
	50	46	22.26	22.11	22.01	21.95	21.80	21.27
	55	51	22.86	22.70	22.59	22.53	22.38	21.76
	60	56	22.86	22.70	22.59	22.53	22.38	21.85
	63	59	22.86	22.70	22.59	22.53	22.38	21.91
	68	64	22.86	22.70	22.59	22.53	22.38	22.02
KNMAB241A 25,600	0	-0.4	13.17	12.99	12.87	12.80	12.61	12.06
	5	4.5	14.84	14.66	14.54	14.47	14.29	13.73
	10	9	16.51	16.33	16.20	16.14	15.96	15.40
	17	15	18.74	18.56	18.42	<b>18.37</b>	18.18	17.59
	20	19	19.57	19.39	19.27	19.20	19.01	18.37
	25	23	20.96	20.77	20.65	20.59	20.40	19.66
	30	28	22.17	21.98	21.85	21.80	21.61	20.96
	35	32	23.37	23.19	23.07	23.00	22.82	22.26
	40	36	24.45	24.27	24.15	24.08	23.90	23.34
	45	41	25.53	25.35	25.23	25.16	24.98	24.42
	47	43	25.97	25.79	25.67	<b>25.60</b>	25.41	24.86
	50	46	26.39	26.21	26.08	26.02	25.83	25.20
	55	51	27.09	26.90	26.78	26.71	26.53	25.79
	60	56	27.09	26.90	26.78	26.71	26.53	25.90
	63	59	27.09	26.90	26.78	26.71	26.53	25.97
	68	64	27.09	26.90	26.78	26.71	26.53	26.08

TC = Total Capacity (kBtu/h).

Nominal capacity as rated 0 ft. above sea level and a 0 ft. level difference between outdoor and indoor units. Corresponding refrigerant piping length is accordance with standard length of each outdoor unit.  
Nominal heating capacity rating obtained with air entering the indoor unit at 70°F dry bulb (DB) and 60°F wet bulb (WB), and outdoor ambient conditions of 47°F dry bulb (DB) and 43°F wet bulb (WB).

Figure 34: Sound Pressure Level Measurement Location.

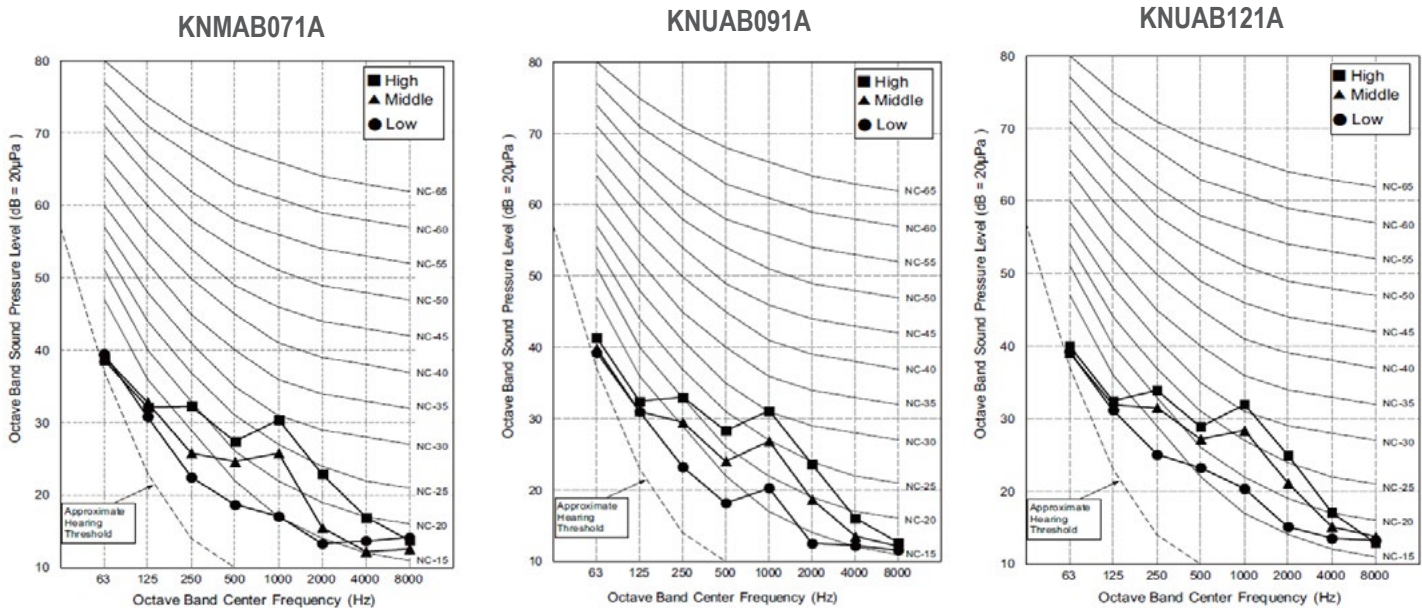


- Measurement taken 2.6' below the bottom of the unit and at a distance of 3.3' from face of unit.
- Measurements taken with no attenuation and units operating at full load normal operating condition.
- Sound level will vary depending on a range of factors such as construction (acoustic absorption coefficient) of particular area in which the equipment is installed.
- Sound power levels are measured in dB(A).
- Tested in anechoic chamber per ISO Standard 3745.

Table 19: Sound Pressure Levels (dB[A]).

Model No.	Sound Pressure Levels (dB[A]) (Cooling and Heating)		
	High Fan Speed	Medium Fan Speed	Low Fan Speed
KNMAB071A	35	31	26
KNUAB091A	36	32	27
KNUAB121A	38	34	29
KNMAB151A	42	38	32
KNUAB181A	44	38	34
KNMAB241A	46	41	36

Figure 35: KNMAB071A, KNUAB091A, and KNUAB121A Sound Pressure Level Diagrams.

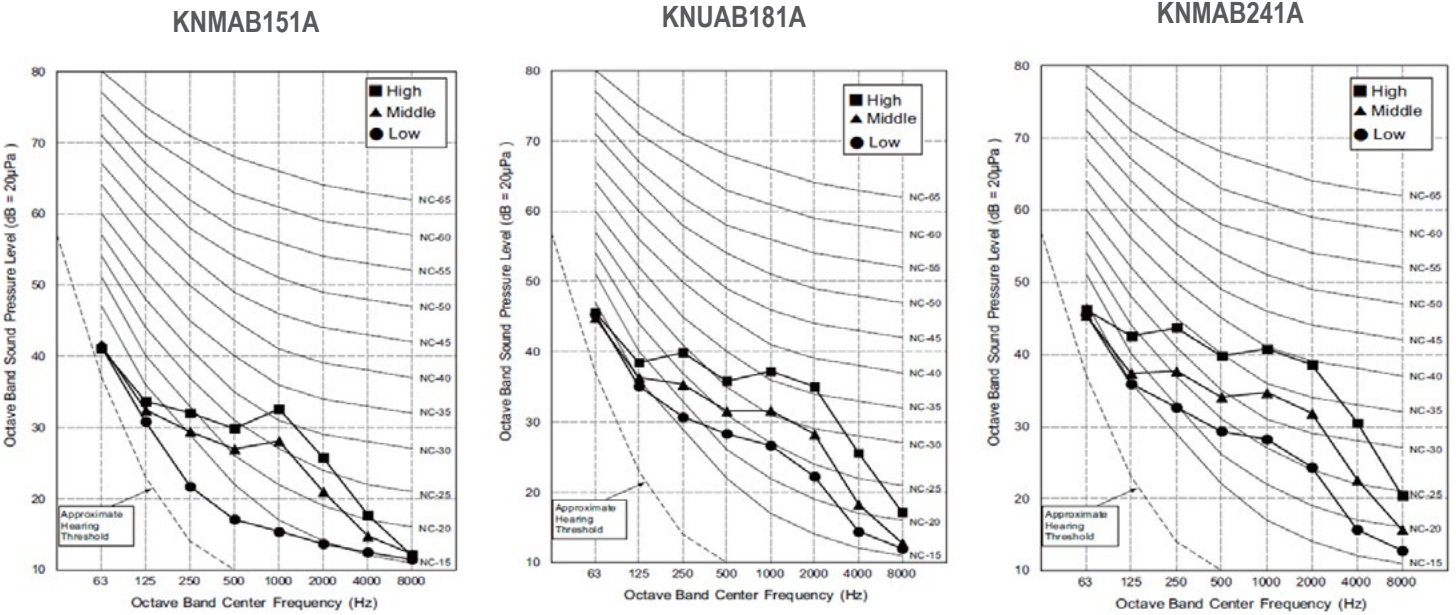


# HIGH EFFICIENCY WALL-MOUNTED INDOOR UNITS

Acoustic Data

MULTI F  
MULTI F MAX

Figure 36: KNMAB151A, KNUAB181A, and KNMAB241A Sound Pressure Level Diagrams.



Multi F and Multi F MAX Indoor Unit Engineering Manual

Figure 37: KNMAB071A, KNUAB091A, KNUAB121A, KNMAB151A Air Velocity and Temperature Distribution Charts.

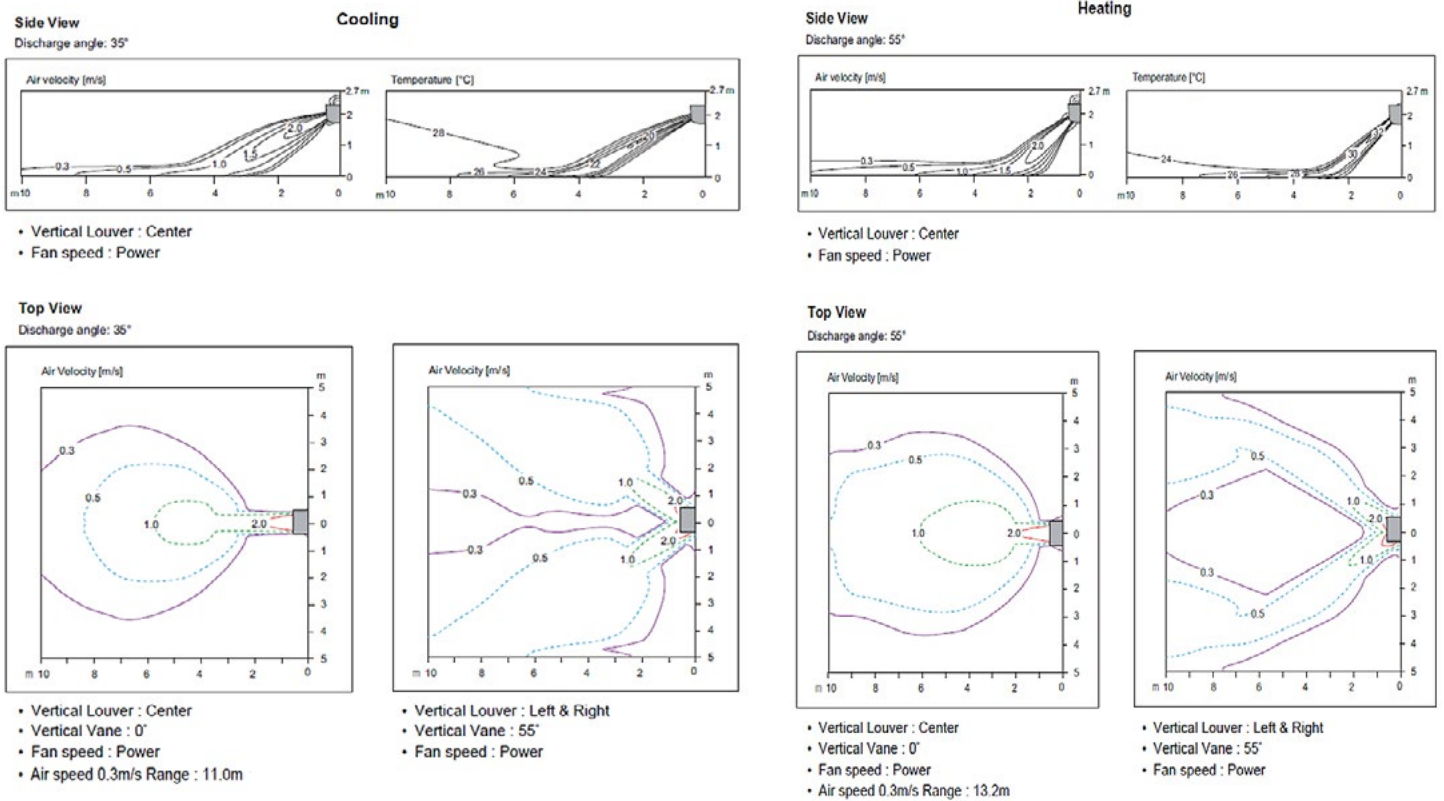
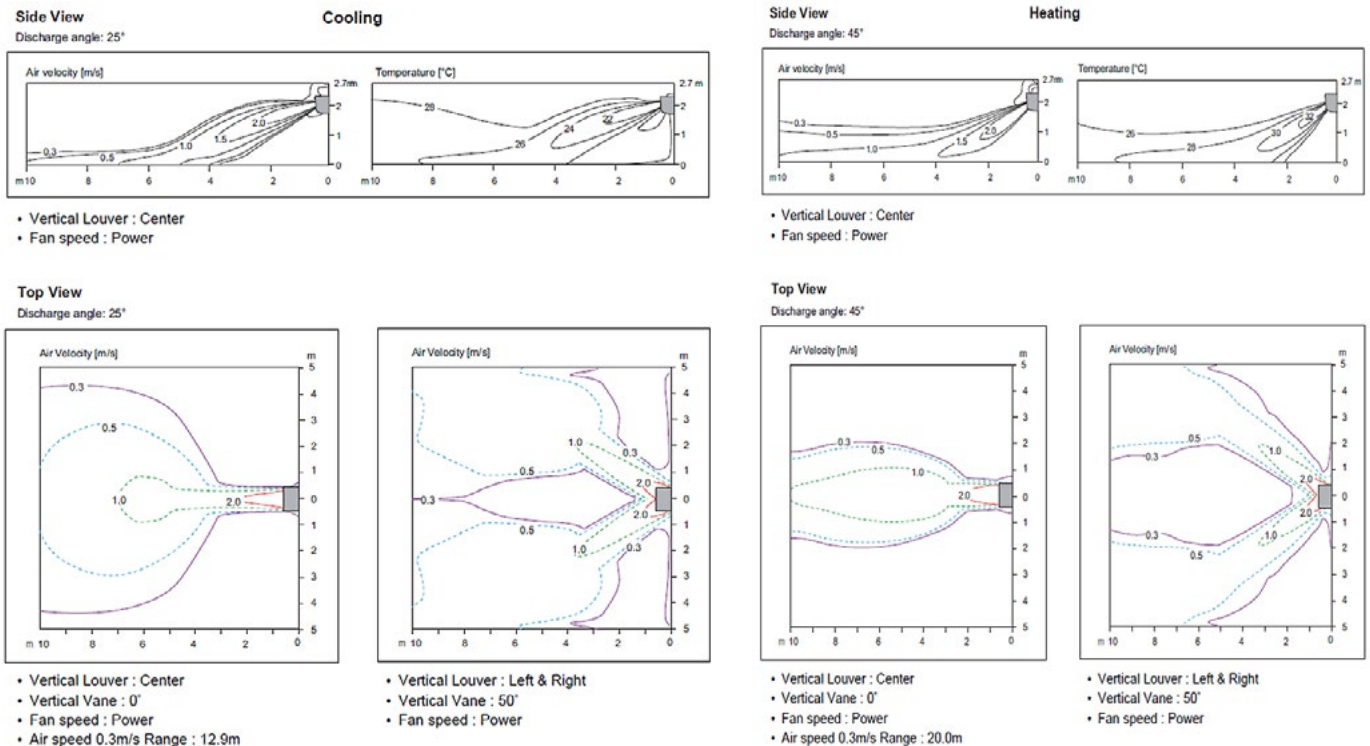


Figure 38: KNUAB181A Air Velocity and Temperature Distribution Charts.

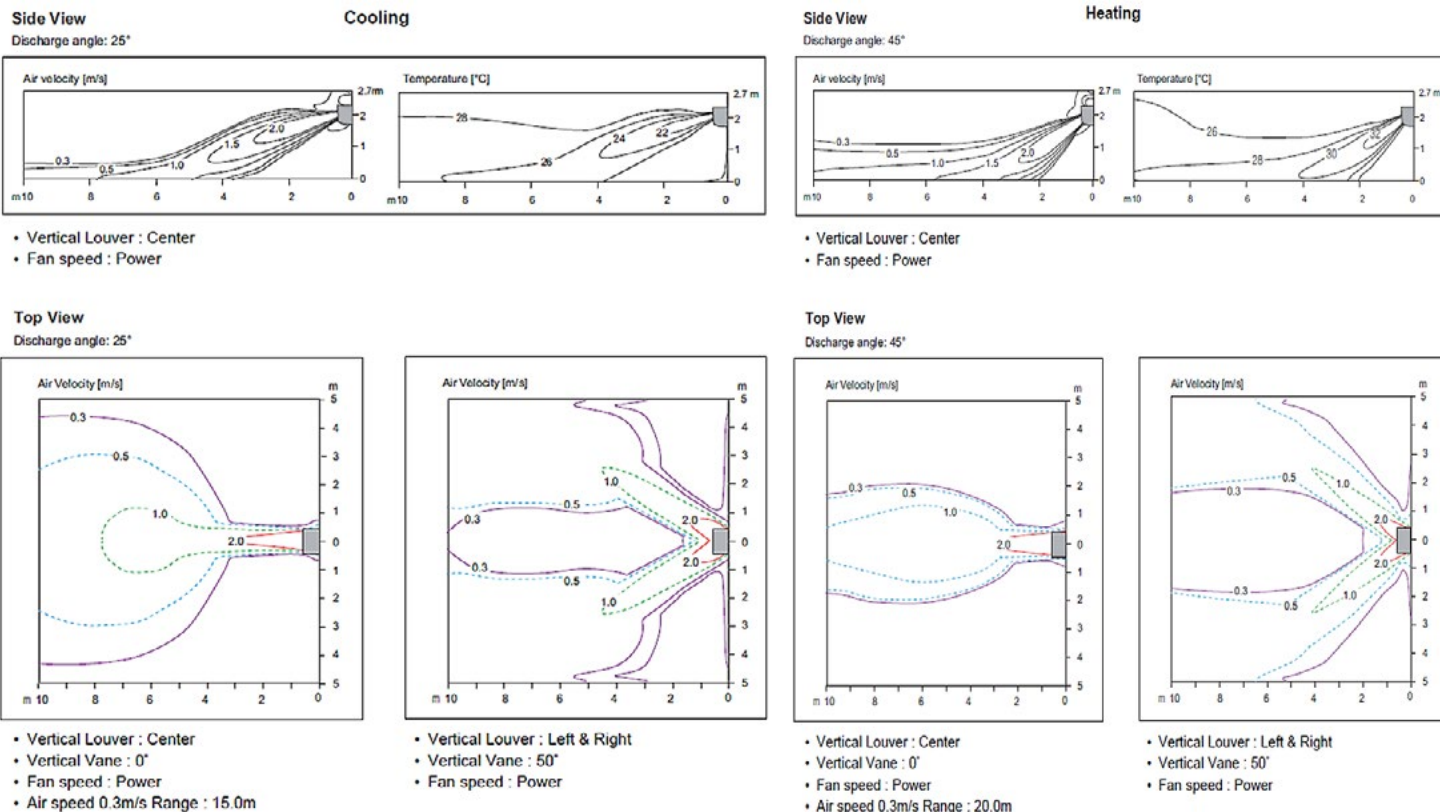


# HIGH EFFICIENCY WALL-MOUNTED INDOOR UNITS

MULTI F  
MULTI F MAX

## Air Velocity and Temperature Distribution

Figure 39: KNMAB241A Air Velocity and Temperature Distribution Charts.



Multi F and Multi F MAX Indoor Unit Engineering Manual

Figure 40: Multi F High Efficiency Wall-Mounted Indoor Unit Refrigerant Flow Diagram.

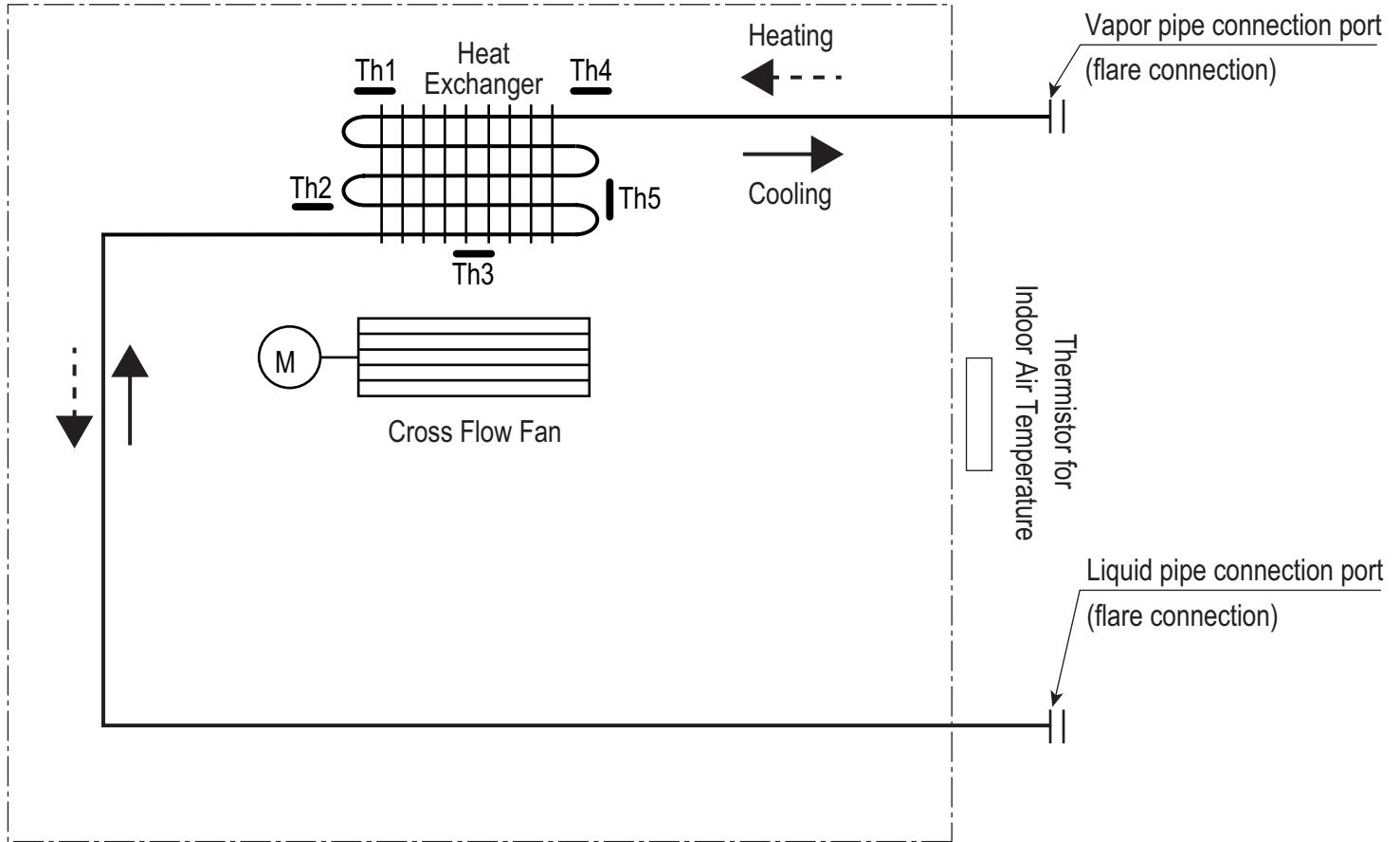


Table 20: Multi F High Efficiency Wall-Mounted Indoor Unit Refrigerant Pipe Sizes.

Model No.	Vapor (inch)	Liquid (inch)
KNMAB071A	Ø3/8	Ø1/4
KNUAB091A		
KNUAB121A		
KNMAB151A		
KNUAB181A	Ø1/2	
KNMAB241A		

Table 21: Multi F High Efficiency Wall-Mounted Indoor Unit Refrigerant Pipe Connections.

Model No.	Vapor (inch)	Liquid (inch)
KNMAB071A	Ø3/8	Ø1/4
KNUAB091A		
KNUAB121A		
KNMAB151A		
KNUAB181A	Ø5/8	Ø3/8
KNMAB241A	Ø1/2	Ø1/4

Table 22: Multi F High Efficiency Wall-Mounted Indoor Unit Thermistor Details.

Location	Description (Based on Cooling Mode)	IDU PCB Connector
Th1	Indoor Air Temperature Thermistor	CN-TH1
Th2	Evaporator Inlet Temperature Thermistor	
Th3	Evaporator Middle Temperature Thermistor	CN-TH2
Th4	Evaporator Outlet Temperature Thermistor	
Th5	Water Level Sensor (Optional)	CN-TH3

# HIGH EFFICIENCY WALL-MOUNTED INDOOR UNITS

MULTI F  
MULTI F MAX

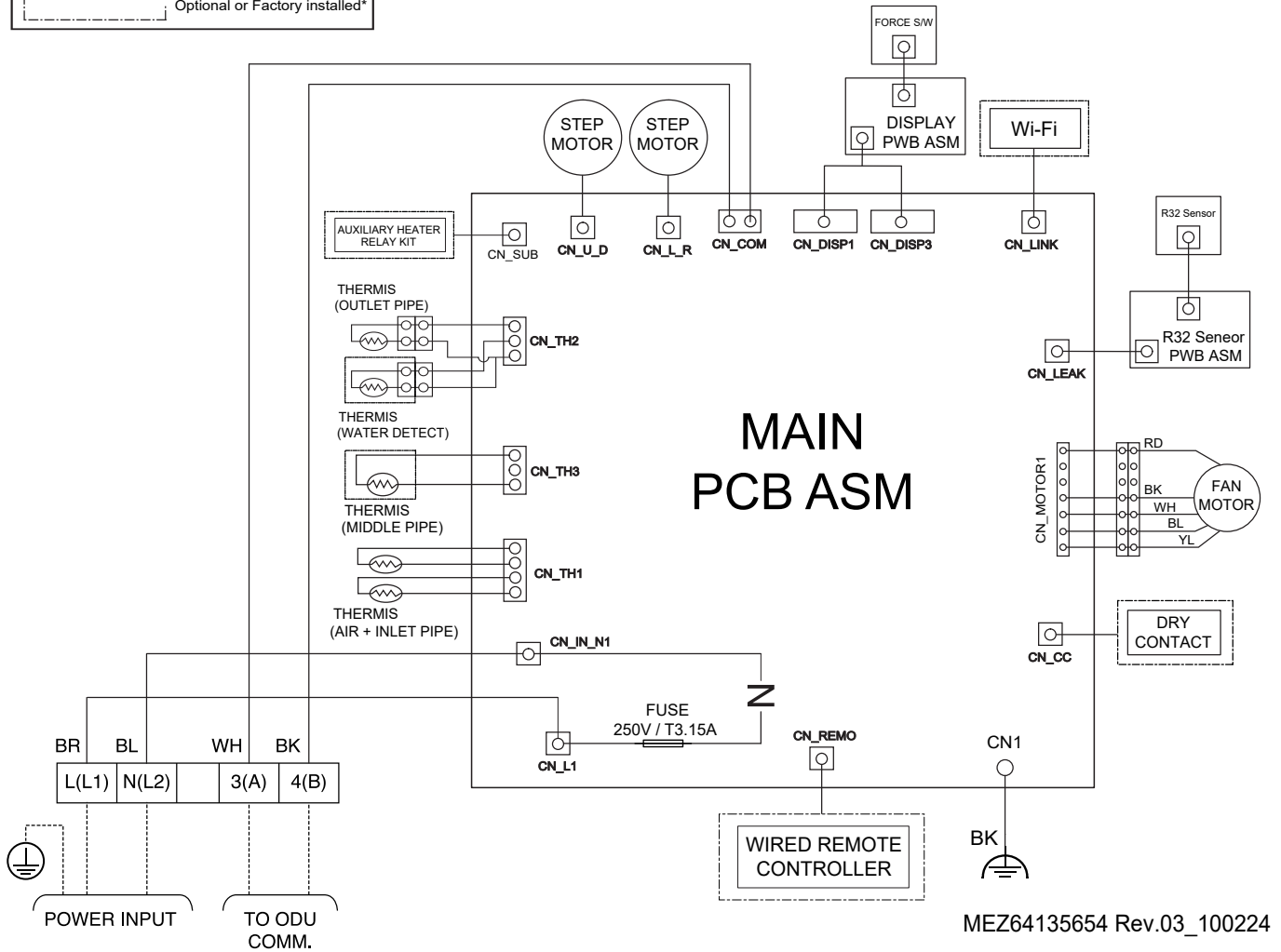
## Wiring Diagram

Figure 41: Multi F High Efficiency Wall-Mounted KNMAB071A, KNUAB091A, KNUAB121A, KNMAB151A, KNUAB181A, KNMAB241A Indoor Units Wiring Diagram.

**INFORMATION**

- You need to buy a dedicated circuit separately.
- Factory Wiring
- - - Field Wiring
- - - Optional or Factory installed\*

USE COPPER CONDUCTORS ONLY  
UTILISER DES FILS D'ALIMENTATION EN CUIVRE



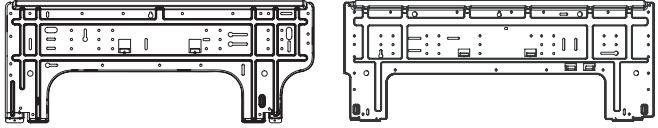
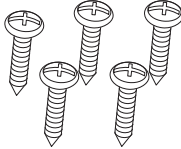
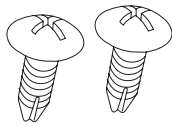

This function can be optional or factory installed depending on the application model.

Multi F and Multi F MAX Indoor Unit Engineering Manual



## Factory Supplied Parts

Table 23: Parts Table.

Part	Quantity	Image
Installation Plate	One (1)	 <p>7,000 ~ 15,000 Btu/h Indoor Units    18,000 and 24,000 Btu/h Indoor Units</p>
Type "A" Screws	Five (5)	
Type "B" Screws (M4 x 12L)	Two (2)	
Wireless Handheld Controller with Holder AKB76044208	One (1)	

## Factory Supplied Materials

- Owner's Manual
- Installation Manual

## Required Tools

- Level
- Screwdriver
- Electric drill
- Hole core drill
- Flaring tool set
- Spanner (Half union)
- Thermometer

## ⚠ WARNING

Installation work must be performed by trained personnel and in accordance with national wiring standards and all local or other applicable codes. Improper installation can result in fire, electric shock, physical injury, or death.

## NOTICE

Read all instructions before installing this product. Become familiar with the unit's components and connections, and the order of installation. Incorrect installation can degrade or prevent proper operation.

# HIGH EFFICIENCY WALL-MOUNTED INDOOR UNITS

MULTI F  
MULTI F MAX

## Installation and Best Layout Practices

### Selecting the Best Installation Location

#### ⚠ DANGER

To avoid the possibility of fire, Ⓣ do not install the unit in an area where combustible gas will generate, flow, stagnate, or leak. Failure to do so will cause serious bodily injury or death. Before beginning installation, read the safety summary at the beginning of this manual.

Select a location for installing the wall-mounted indoor unit (IDU) that meets the following conditions:

- Where there is enough structural strength to bear the weight of the unit
- Where air circulation will not be blocked
- Where noise prevention is taken into consideration
- Ensure there is sufficient space from the ceiling and floor, and sufficient maintenance space
- Locate the indoor unit in a location where it can be easily connected to the outdoor unit/branch distribution unit
- Include space for drainage to ensure condensate flows properly out of the unit when it is in cooling mode
- Use a level indicator to ensure the unit is installed on a level plane

#### NOTICE

The unit will be damaged, will malfunction, and/or will not operate as designed if installed in any of the following conditions:

- Ⓣ Do not install the unit where it will be subjected to direct thermal radiation from other heat sources.
- Ⓣ Do not install the unit in an area where combustible or corrosive gases will generate, flow, stagnate, or leak.
- Ⓣ Do not install the unit in a location where acidic solution and spray (sulfur) are often used.
- Ⓣ Do not use the unit in environments where oil, steam, or sulfuric gas are present.
- Ⓣ Do not install additional ventilation products on the chassis of the unit.
- Ⓣ Do not install the unit near high-frequency generator sources.
- Ⓣ Do not install the unit near a doorway.

#### NOTICE

- Ⓣ Indoor units (IDUs) must not be placed in an environment where the IDUs will be exposed to harmful volatile organic compounds (VOCs) or in environments where there is improper air make up or supply or inadequate ventilation. If there are concerns about VOCs in the environment where the IDUs are installed, proper air make up or supply and/or adequate ventilation must be provided. Additionally, in buildings where IDUs will be exposed to VOCs, consider a third party factory-applied epoxy coating to the fan coils for each IDU where the entire coil is dipped, not sprayed.
- If the unit is installed near a body of water, the installation parts are at risk of corroding. Appropriate anti-corrosion methods must be taken for the unit and all installation parts.

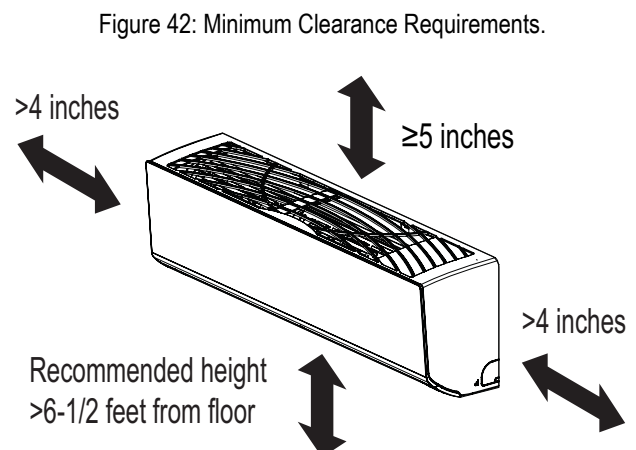
#### Installing in an Area Exposed to Unconditioned Air

In some installation applications, areas (floors, walls) in some rooms will be exposed to unconditioned air (room will be above or next to an unheated garage or storeroom). To countermeasure:

- Verify that carpet is or will be installed (carpet will increase the temperature by three degrees).
- Add insulation between the floor joists.
- Install radiant heat or another type of heating system to the floor.

#### Required Clearances

Figure 42 shows required clearance distances around a typical installed wall-mounted unit.



### Mounting the Installation Plate

The mounting wall must be strong and solid enough to protect the unit from vibration.

- Mount the installation plate on the wall using the Type "A" screws. If mounting the unit on concrete, consider using anchor bolts.
- Always mount the installation plate horizontally. Measure the wall and mark the centerline using thread and a level.

Figure 43: Installation Plate—Side View.

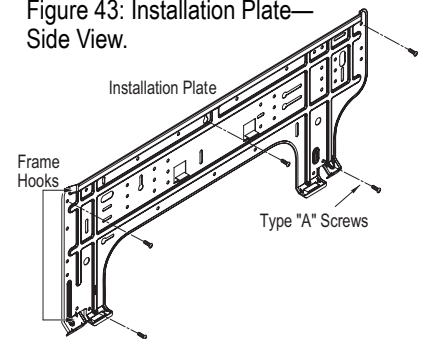


Figure 44: Installation Plate for KNMAB071A, KNUAB091A, KNUAB121A, and KNMAB151A Units.

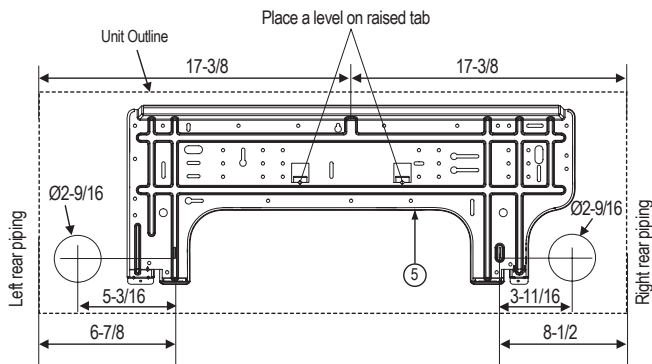
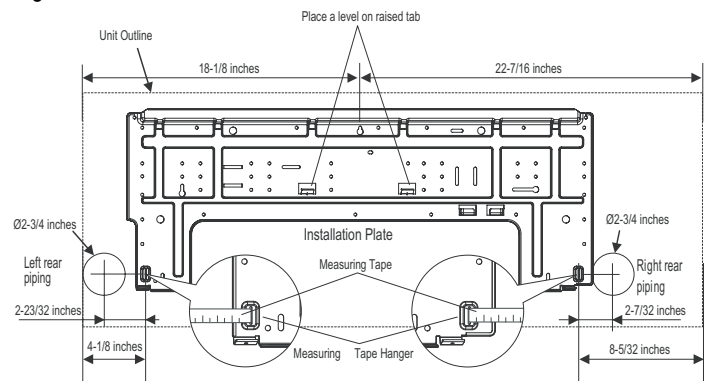


Figure 45: Installation Plate for KNUAB181A and KNMAB241A Units.



### NOTICE

If the unit is installed near a body of water, certain components are at risk of being corroded. Appropriate anti-corrosion methods must be taken for the unit and all components.

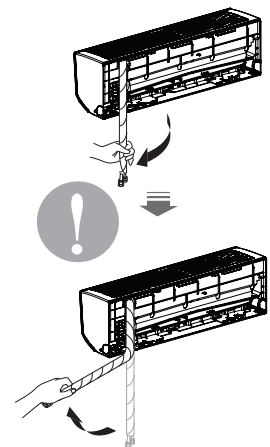
### Preparing for Installation

Prepare the refrigerant piping and drain hose (indoor unit piping) for installation through the wall: press on the top of the tubing clamp and slowly guide the piping / hose down (depending on installation requirements, then to the left or right). Relock the tubing clamp after the piping / hose are released.

### NOTICE

⊘ Do not bend the piping / drain hose from side to side; it will damage the components.

Figure 46: Preparing for Installation.



# HIGH EFFICIENCY WALL-MOUNTED INDOOR UNITS

## Installation and Best Layout Practices

MULTI F  
MULTI F MAX

### Drilling Piping Hole in the Wall

#### ⚠ WARNING

Use caution when drilling holes through walls. Drilling into power wiring in the wall can cause serious bodily injury or death.

Follow the left or right piping clearance recommendations.

1. Using a 2-5/8 (ø 65mm) inch hole core drill bit, drill a hole at either the right or left side of the wall mounting. The hole must slant 3/16" to 5/16" from level (upward on the indoor unit side and downward on the outdoor unit side).
2. Finish off the newly drilled hole as shown with bushing and sleeve covering. Sleeve and bushing prevents damage to the tubing/bundling of the piping.

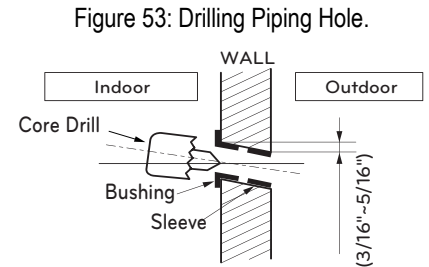


Figure 53: Drilling Piping Hole.

### Hanging the Indoor Unit Frame

1. Attach the three (3) hooks on the top of the indoor unit to the top edge of the installation plate. Verify the hooks are properly attached to the installation plate by gently shaking the indoor unit from side to side.
2. Unlock the tubing clamp from the indoor unit frame. For easier access between the bottom of the indoor unit and the wall, prop the clamp between the indoor unit frame and installation plate.
3. Remove the screw covers at the bottom of the indoor unit, unscrew the two (2) screws, remove the frame cover, remove the piping connection cover, and position the piping for installation (down, back, left, or right).

Figure 47: Locking the Indoor Unit onto the Installation Plate.

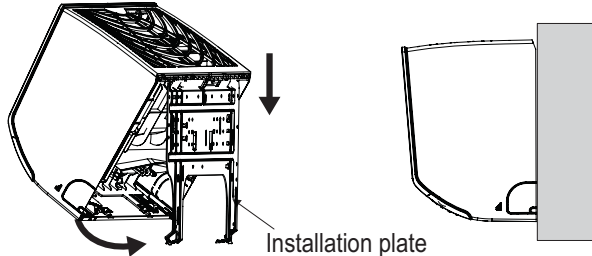


Figure 48: Accessing the Back of the Indoor Unit.

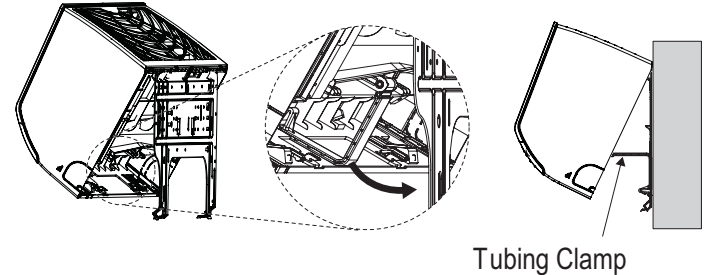


Figure 49: Removing the Frame Cover.

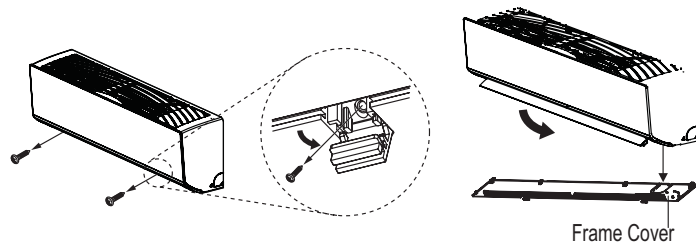


Figure 50: Exterior Back View of Indoor Unit.

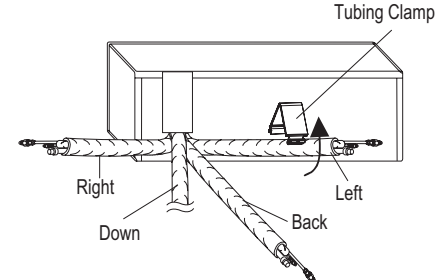


Figure 51: Piping Installed to the Left.

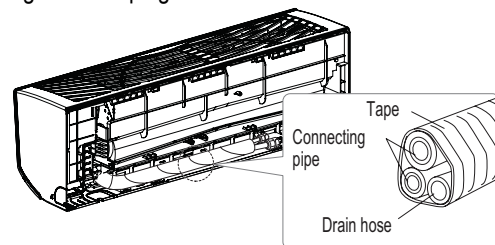
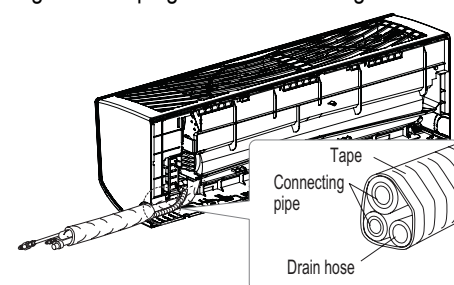


Figure 52: Piping Installed to the Right.



### Power Wiring / Communications Cable Guidelines

- Follow manufacturer’s circuit diagrams in the technical manuals.
- Confirm power source specifications.
- Confirm that the electrical capacity is sufficient.
- Starting current must be maintained  $\pm 10$  percent of the rated current marked on the outdoor unit name plate.
- Confirm cable thickness specifications.
- It is required that a circuit breaker is installed, especially if conditions could become wet or moist.
- Include a disconnect in the power wiring system, add an air gap contact separation of at least 1/8 inch in each active (phase) conductor.

### ⚠ WARNING

• Loose wiring will cause unit to malfunction, overheat, and catch fire, resulting in severe injury or death.

### NOTICE

- Terminal screws will become loose during transport. Properly tighten the terminal connections during installation.
- A voltage drop will cause the following problems:
- Magnetic switch vibration, fuse breaks, or disturbance to the normal function of an overload protection device.
  - Compressor will not receive the proper starting current.

### Connect Power Wiring and Communications Cable

1. Insert the power wiring / communications cable from the outdoor unit or branch distribution unit (Multi F MAX systems only) through the bottom of the indoor unit.
2. Connect each wire to its appropriate terminal on the indoor unit control board. Verify that the color and terminal numbers from the outdoor unit or branch distribution unit (Multi F MAX systems only) wiring match the color and terminal numbers on the indoor unit.
3. Secure power wiring/communications cable with cable restraint.

Figure 54: Connecting Power Wiring / Communications Cable.

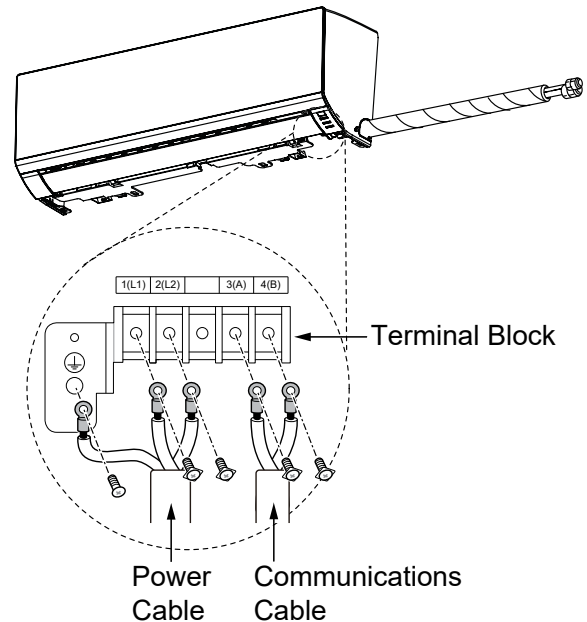
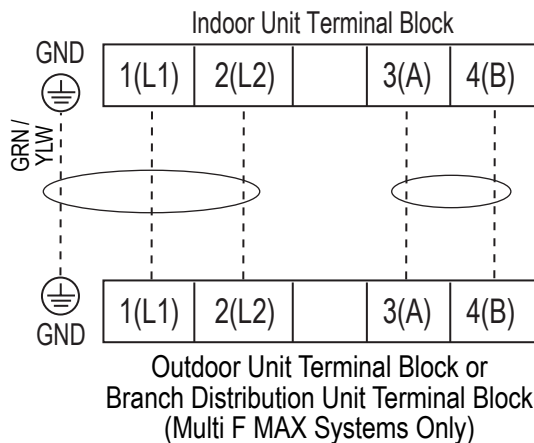


Figure 55: Simplified View of Indoor Unit to Outdoor Unit / Branch Distribution Unit Terminal Connections.



# HIGH EFFICIENCY WALL-MOUNTED INDOOR UNITS

## Installation and Best Layout Practices

MULTI F  
MULTI F MAX

### Controller Options

High Efficiency wall-mounted indoor units include a wireless controller (AKB74955602), but optional LG-supplied wired controllers are available.

#### Wireless Controller

Figure 56: AKB76044208 Wireless Controller.

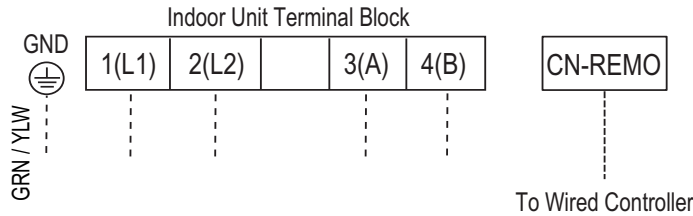
Table 24: AKB76044208 Wireless Controller Functions.



Image	Description
	<b>Power</b> Turns the appliance on or off.
	<b>Connecting to LG ThinQ</b> Press and hold the Power button for about 3 seconds to prepare for connecting appliance and Wi-Fi.
	<b>Mode</b> Selects the desired operating mode. • Each press changes the mode in this order: Cooling ~ Auto ~ Dehumidification ~ Heating ~ Fan 7 & 8 Press and hold the Mode button for about 3 seconds to change units between 7 and 8
	<b>AI/AEC</b> Selects AI Smart Care or Active Energy Control to decrease the power input. <b>NOTE</b> • When connected to the Multi Outdoor unit, Active Energy Control function may not be supported.
	<b>Temperature J , K</b> Adjusts the desired room temperature.
	<b>Fan Speed ~ , !</b> Adjusts the fan speed.
	<b>y (Up-Down Swing)</b> Adjusts the airflow direction up and down. <b>Cmft Air</b> Press and hold the y button for about 3 seconds to adjust the airflow direction. This will help minimize direct contact with airflow.
	<b>A (Left-Right Swing)</b> Adjusts the airflow direction left and right.
	<b>Jet</b> Changes the room temperature quickly and operates at maximum fan speed. <b>Exit</b> When entering the settings, press and hold the Jet button for about 3 seconds to return the previous setting.
	<b>Function</b> Selects the desired function. <b>NOTE</b> • When connected to the Multi Outdoor unit, Low Ambient Heating function may not be supported.
	<b>H (Sleep)</b> Automatically turns the appliance off at a desired time. Use it before sleeping. <b>Night Mode</b> Press and hold the H button for about 3 seconds to turn off the display and the beep sound.
	<b>a Reset</b> Resets the wireless remote control setting.

### Wired Controller Connections

Figure 57: Wired Controller Connection on Indoor Unit Terminal Block.

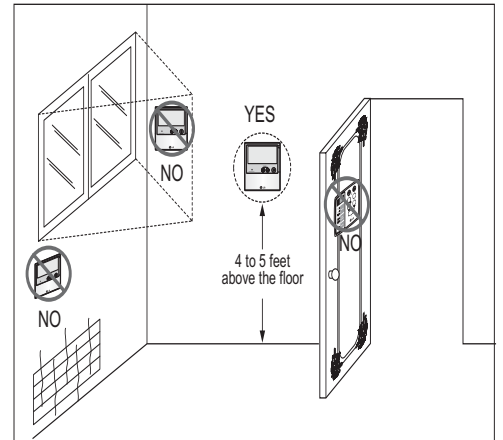


### Wired Controller Placement

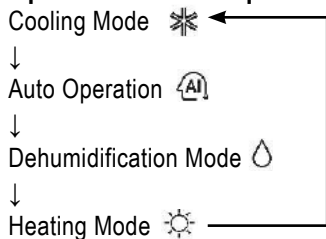
Wired controllers include a sensor to detect room temperature. To maintain comfort levels in the conditioned space, the wired controller must be installed in a location away from direct sunlight, high humidity, and where it could be directly exposed to cold air. Controller must be installed four (4) to five (5) feet above the floor where its LED display can be read easily, in an area with good air circulation, and where it can detect an average room temperature.

- ⊘ Do not install the wired controller near or in:
- Drafts or dead spots behind doors and in corners
  - Hot or cold air from ducts
  - Radiant heat from the sun or appliances
  - Concealed pipes and chimneys
  - An area where temperatures are uncontrolled, such as an outside wall

Figure 58: Proper Location for the Wired Controller.



### Operation Mode Sequence



# HIGH EFFICIENCY WALL-MOUNTED INDOOR UNITS

## Installation and Best Layout Practices

MULTI F  
MULTI F MAX

### Hanging the Wired Controller

1. The controller wiring / cable can be installed in one of three directions: top, back, or on the right side. If top or right side installation is desired, remove cable guide grooves on the controller, and then position wiring / cable on applicable side.
2. Choose and mark the area of installation. Use the provided parts and screw the wall plate into place. Install the controller wall plate to fit the electrical box if one is present. Ensure that no gaps exist between the wall plate and the wall itself.
3. Arrange wiring / cables so as not to interfere with the controller circuitry. Position the wired controller on the wall plate. Snap into place by pressing the bottom part of the wired controller onto the wall plate. Make sure that no gaps exist between the wired controller and the wall plate on all sides.
4. To remove wired controller from the wall plate, insert a screwdriver into the two holes at the bottom. Twist screwdriver to release controller. ⚠ Do not damage the controller components when removing.

Figure 60: Removing the Cable Guide Grooves.

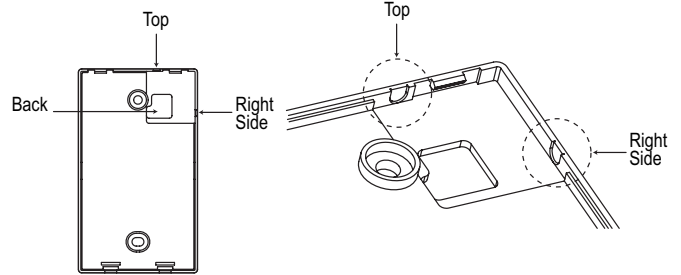


Figure 61: Attaching the Wall Plate.

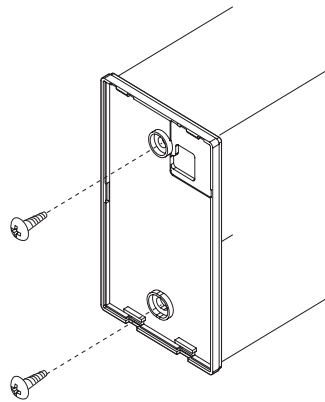
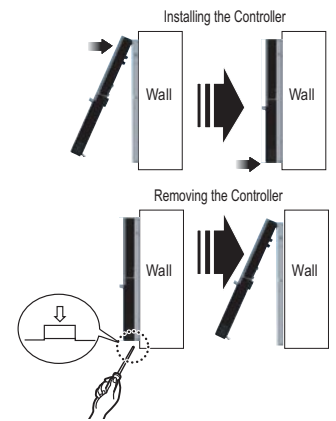


Figure 62: Installing / Removing the Controller.



### Assigning the Thermistor for Temperature Detection

Each indoor unit includes a return air thermistor assigned to sense the temperature. If a wired controller is installed, there is a choice of sensing temperature with either the indoor unit return air thermistor or the thermistor in the wired controller. It is also an option to set both thermistors to sense temperature so that indoor unit bases its operation on the first thermistor to reach the designated temperature differential. For applicable indoor units, an optional Remote Temperature Sensor can be used in lieu of the return air thermistor—either alone or in conjunction with a wired controller thermistor as previously described.

### Finalizing Indoor Unit Installation

1. Move the tubing clamp to its original position.
2. Ensure the three (3) hooks are properly attached to the installation plate by gently shaking the indoor unit from side to side.
3. Press the bottom left and right sides of the indoor unit against the installation plate until the hooks click firmly into their slots.
4. Using two (2) Type “C” screws, secure the bottom of the indoor unit to the installation plate.
5. Remove the two (2) tabs from the filter.
6. Replace the frame cover.

Figure 59: Attach Bottom of Indoor Unit to Installation Plate.

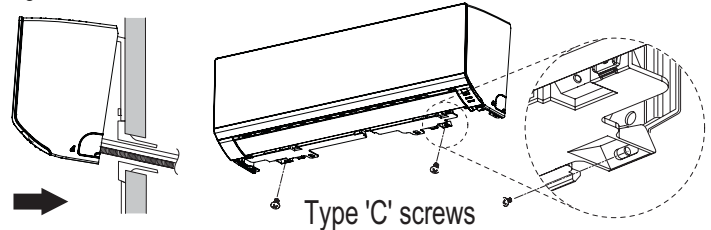
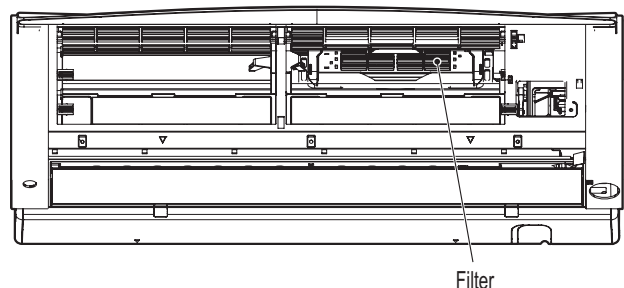


Figure 63: Removing the Filter Tabs.



# LOW WALL CONSOLE INDOOR UNIT DATA

**Mechanical Specifications on page 54**

**General Data / Specifications on page 55**

**Dimensions on page 56**

**Cooling Capacity Table on page 57**

**Heating Capacity Table on page 59**

**Acoustic Data on page 60**

**Air Velocity and Temperature Distribution on page 62**

**Refrigerant Flow Diagram on page 63**

**Wiring Diagram on page 64**

**Factory Supplied Parts and Materials on page 65**

**Installation and Best Layout Practices on page 67**

# LOW WALL CONSOLE INDOOR UNITS

## Mechanical Specifications and Features

MULTI F  
MULTI F MAX

### Low Wall Console Indoor Units

#### General

All LG indoor units are factory assembled, wired, piped, and provided with a control circuit board, fan, and motor. Low Wall Console units have a sound rating no higher than 44 dB(A) as tested per KSA0701 ISO Low 3745.

#### Coil

Indoor unit coils are comprised of a minimum of two rows of aluminum fins mechanically bonded to copper tubing. The coils are pressure tested at the factory. Each unit is provided with a factory installed condensate drain pan below the coil.

#### Refrigerant System

The system is designed for use with R32 refrigerant. The refrigeration circuit is pressure-tested at the factory and shipped with a holding charge of helium gas. Refrigerant pipe connections are 45° flare. All refrigerant lines from the outdoor unit to the indoor units must be field insulated.

#### Electrical

The indoor units require 208–230Vac/60Hz/1Φ power with voltage variance of no more than ±10%.

#### Casing

The units mount on a vertical surface. They are shipped with a separate back plate that secures the unit to the wall, protruding no more than nine (9) inches. Refrigerant piping can be installed in one (1) of four (4) different directions.

#### Finish

The Low Wall Console unit has a case with a beige-white panel. It is manufactured of heavy-duty acrylonitrile butadiene styrene (ABS) and high impact polystyrene (HIPS) plastic.

#### Fan Assembly and Control

The unit has a single, direct-drive, turbo fan made of high strength ABS plastic. The fan motor is brushless digitally controlled (BLDC) with permanently lubricated and sealed ball bearings. The fan / motor assembly is mounted on vibration attenuating rubber grommets. Fan speed is controlled using a microprocessor-based direct digitally controlled algorithm that provides pre-programmed, field-selectable fixed or auto fan speeds in the Heating and Cooling modes. For Low Wall Console units, the indoor fan has Low, Med, High, Jet Cool, and Auto settings for Cooling mode; and has Low, Med, High, Jet Heat, and Auto settings for Heating mode. The Auto setting adjusts the fan speed based on the difference between the controller setpoint and space temperature.

#### Air Filter

The return air inlet has a factory-supplied primary removable, washable filter. The filter is accessed from the front of the unit without the use of tools.

### Features

- Inverter (Variable speed fan)
- Comfort Air
- Jet cool/Jet Heat
- Group control
- Auto operation
- Auto restart operation
- Optional wi-fi
- Self-diagnostic function
- Wireless LCD remote control included

#### Airflow Guide Vanes

A factory-installed motorized guide vane controls the direction of airflow up and down for uniform air distribution. Side to side control is manual.

#### Microprocessor Control

The indoor unit has an integrated control panel to communicate with the outdoor unit. All unit operation parameters are stored in non-volatile memory resident on the unit microprocessor. The microprocessor controls space temperature through using the value provided by the temperature sensors within the indoor unit. The microprocessor control will activate indoor unit operation when the indoor room temperature falls below or rises above a setpoint temperature, at which point, a signal is sent to the outdoor unit to begin the appropriate mode. The microprocessor also provides self-diagnostics and auto restart functions. A field-supplied three-wire power cable (3 x 14 AWG) and two-wire communications cable (2 x 18 AWG) must be installed to connect the indoor unit(s) to the outdoor unit.

#### R32 Refrigerant Leak Detector

The indoor unit has a built-in R32 refrigerant leak detection sensor designed to communicate with release mitigation devices and third party alarms, and transmit a system error code upon detection of a refrigerant leak or sensor failure / expiration.

#### Shut-off Valve

LG single-port shutoff valve (PRHPZ010A; sold separately) is available as an accessory.

#### Controls

The indoor unit casing has an integral infrared sensor to communicate with the supplied LG wireless handheld remote controller. An optional LG supplied wired controller is available as an additional accessory. Communication between the indoor units and the outdoor unit is accomplished through 18 AWG, two-core, stranded and shielded communication cable. The indoor unit has an option for wi-fi and can be controlled with LG's SmartThinQ app on a smart device. A field-supplied wi-fi network and smart device are required. The SmartThinQ app is free and is available for Android and iOS smart devices.

#### Condensate

The unit is designed for gravity draining of condensate and includes a flexible drain hose capable of installation in one of two directions.



Table 25: Multi F Low Wall Console Indoor Unit General Data.

Model Name	KNUQB091A	KNUQB121A	KNMQB151A
Nominal Cooling Capacity (Btu/h) <sup>1</sup>	9,000	12,000	15,710
Nominal Heating Capacity (Btu/h) <sup>1</sup>	10,600	13,650	17,070
<i>Operating Range</i>			
Cooling (°F WB)	57-77		
Heating (°F DB)	59-81		
<i>Fan</i>			
Type	Turbo		
Motor Output (W) x Qty.	48 x 1		
Motor/Drive	Brushless Digitally Controlled / Direct		
Airflow Rate CFM (Max/H/M/L)	318 / 300 / 237 / 177	353 / 318 / 244 / 184	388 / 357 / 304 / 254
<i>Unit Data</i>			
Refrigerant Type <sup>2</sup>	R32		
Refrigerant Control	EEV		
Power Supply V, Ø, Hz <sup>3</sup>	208-230, 1, 60		
Rated Amps (A)	0.7		
Sound Pressure Level dB(A) (H/M/L) <sup>4</sup>	38 / 32 / 27	39 / 32 / 27	44 / 39 / 35
Dimensions (W x H x D, in.)	27-9/16 x 23-5/8 x 8-9/32		
Net Unit Weight (lbs.)	33.7		
Shipping Weight (lbs.)	39.7		
Power Wiring Cable (No. x AWG) <sup>5</sup>	3 x 14		
Communications Wiring Cable (No. x AWG) <sup>5</sup>	2 x 18		
Heat Exchanger (Row x Column x FPI) x Qty.	(2 x 19 x 19) x 1		
Dehumidification Rate (pts/hr)	1.72	2.3	4.4
<i>Pipe Size</i>			
Liquid (in.)	1/4	1/4	1/4
Vapor (in.)	3/8	3/8	1/2
<i>Connection Size</i>			
Liquid (in.)	1/4	1/4	1/4
Vapor (in.)	3/8	3/8	1/2
Drain O.D. / I.D. (in.)	21/32, 15/32		

<sup>1</sup>Nominal capacity is rated 0 ft. above sea level with corresponding refrigerant piping length in accordance with low length of each outdoor unit and a 0 ft. level difference between outdoor and indoor units. All capacities are net with a combination ratio between 95 – 105%.

Nominal cooling capacity rating obtained with air entering the indoor unit at 80°F dry bulb (DB) and 67°F wet bulb (WB) and outdoor ambient conditions of 95°F dry bulb (DB) and 75°F wet bulb (WB).  
Nominal heating capacity rating obtained with air entering the indoor unit at 70°F dry bulb (DB) and 60°F wet bulb (WB) and outdoor ambient conditions of 47°F dry bulb (DB) and 43°F wet bulb (WB).

<sup>2</sup>This unit comes with a dry helium charge.

<sup>3</sup>Acceptable operating voltage: 187V-253V.

<sup>4</sup>Sound pressure levels are tested in an anechoic chamber under ISO Low 3745 and are the same in both cooling and heating mode. These values can increase due to ambient conditions during operation.

<sup>5</sup>The power wiring and the communication wiring from the outdoor unit to the indoor unit, or from the branch distribution unit to the indoor unit is field supplied and must be stranded, shielded or unshielded (if shielded, it must be grounded to the chassis of the outdoor unit only). All wiring must comply with applicable local and national codes.

# LOW WALL CONSOLE INDOOR UNITS

## Dimensions

MULTI F  
MULTI F MAX

Figure 65: KNUQB091A, KNUQB121A, and KNMQB151A Dimensions.

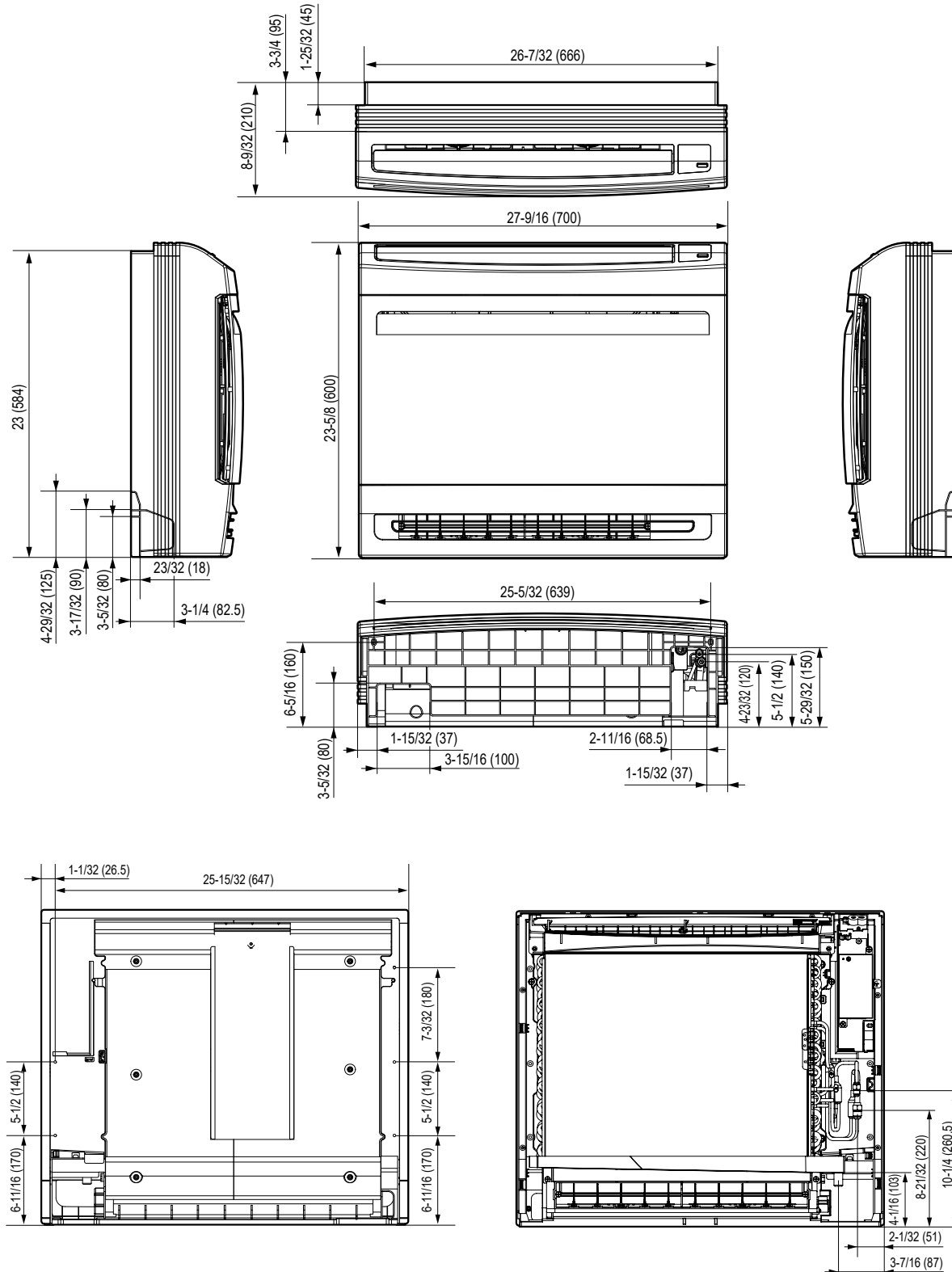


Table 26: Multi F Low Wall Console Indoor Units Cooling Capacity Table.

Model No. / Nominal Capacity of Indoor Unit (Btu/h)	Outdoor Air Temp. (°F DB)	Indoor Air Temp. °F DB / °F WB											
		68 / 57		73 / 61		77 / 64		80 / 67		86 / 72		90 / 75	
		TC	SHC	TC	SHC	TC	SHC	TC	SHC	TC	SHC	TC	SHC
KNUQB091A 9,000	14	8.82	6.19	9.37	6.54	9.92	6.33	10.31	6.47	11.01	6.52	11.56	6.65
	20	8.82	6.24	9.36	6.59	9.91	6.38	10.31	6.52	11.01	6.57	11.55	6.70
	25	8.81	6.29	9.36	6.64	9.90	6.43	10.30	6.57	11.00	6.62	11.54	6.75
	30	8.80	6.34	9.35	6.70	9.90	6.48	10.29	6.62	10.99	6.68	11.54	6.80
	35	8.80	6.39	9.34	6.75	9.89	6.53	10.28	6.67	10.98	6.73	11.53	6.85
	40	8.79	6.43	9.33	6.80	9.88	6.58	10.27	6.72	10.97	6.78	11.52	6.90
	45	8.78	6.48	9.33	6.85	9.87	6.63	10.27	6.77	10.96	6.83	11.51	6.96
	50	8.78	6.53	9.32	6.90	9.87	6.68	10.26	6.82	10.96	6.88	11.50	7.01
	55	8.77	6.58	9.31	6.95	9.86	6.73	10.25	6.87	10.95	6.93	11.49	7.06
	60	8.76	6.63	9.31	7.00	9.85	6.78	10.24	6.92	10.94	6.98	11.48	7.11
	65	8.76	6.67	9.30	7.05	9.84	6.83	10.24	6.97	10.93	7.03	11.47	7.16
	70	8.75	6.72	9.29	7.10	9.84	6.87	10.23	7.02	10.92	7.08	11.47	7.21
	75	8.75	6.61	9.08	6.99	9.62	6.78	10.01	6.93	10.71	6.99	11.25	7.13
	80	8.33	6.50	8.87	6.88	9.41	6.68	9.80	6.83	10.49	6.90	11.03	7.05
	85	8.12	6.38	8.66	6.77	9.20	6.58	9.59	6.73	10.28	6.81	10.82	6.96
	90	7.91	6.26	8.45	6.65	8.99	6.47	9.37	6.63	10.06	6.72	10.60	6.87
	95	7.68	6.19	8.22	6.59	8.75	6.42	<b>9.00</b>	<b>6.48</b>	9.83	6.68	10.36	6.84
	100	7.50	6.03	8.03	6.42	8.57	6.27	8.88	6.38	9.64	6.54	10.17	6.70
	105	7.31	5.86	7.84	6.26	8.38	6.11	8.77	6.28	9.45	6.39	9.99	6.56
	110	7.12	5.66	7.66	6.05	8.19	5.92	8.58	6.09	9.26	6.21	9.80	6.38
115	6.94	5.49	7.47	5.88	8.01	5.77	8.39	5.94	9.08	6.06	9.61	6.23	
118	6.82	5.45	7.36	5.85	7.89	5.74	8.28	5.91	8.96	6.04	9.50	6.22	
122	6.79	5.44	7.32	5.84	7.86	5.73	8.24	5.90	8.93	6.04	9.46	6.21	
KNUQB121A 12,000	14	11.76	8.37	12.49	8.84	13.22	8.56	13.75	8.74	14.69	8.82	15.42	8.98
	20	11.75	8.44	12.48	8.91	13.21	8.63	13.74	8.81	14.67	8.89	15.40	9.05
	25	11.75	8.50	12.48	8.98	13.20	8.70	13.73	8.88	14.66	8.96	15.39	9.12
	30	11.74	8.57	12.47	9.05	13.19	8.76	13.72	8.95	14.65	9.02	15.38	9.19
	35	11.73	8.63	12.46	9.12	13.18	8.83	13.71	9.02	14.64	9.09	15.37	9.26
	40	11.72	8.70	12.45	9.19	13.17	8.90	13.70	9.08	14.63	9.16	15.36	9.33
	45	11.71	8.76	12.44	9.26	13.16	8.96	13.69	9.15	14.62	9.23	15.35	9.40
	50	11.70	8.83	12.43	9.33	13.15	9.03	13.68	9.22	14.61	9.30	15.33	9.47
	55	11.69	8.89	12.42	9.39	13.14	9.10	13.67	9.29	14.60	9.37	15.32	9.54
	60	11.68	8.96	12.41	9.46	13.13	9.16	13.66	9.35	14.59	9.43	15.31	9.61
	65	11.67	9.02	12.40	9.53	13.12	9.23	13.65	9.42	14.57	9.50	15.30	9.68
	70	11.66	9.09	12.39	9.60	13.11	9.29	13.64	9.49	14.56	9.57	15.29	9.75
	75	11.38	8.94	12.11	9.45	12.83	9.16	13.35	9.36	14.27	9.45	15.00	9.64
	80	11.10	8.78	11.82	9.30	12.55	9.03	13.07	9.23	13.99	9.33	14.71	9.53
	85	10.83	8.62	11.54	9.15	12.26	8.89	12.78	9.10	13.70	9.21	14.42	9.41
	90	10.55	8.46	11.26	8.99	11.98	8.74	12.50	8.96	13.42	9.08	14.13	9.28
	95	10.25	8.37	10.96	8.91	11.67	8.68	<b>12.00</b>	<b>8.76</b>	13.10	9.03	13.81	9.24
	100	10.00	8.15	10.71	8.68	11.42	8.47	11.84	8.62	12.85	8.84	13.56	9.05
	105	9.75	7.92	10.46	8.46	11.17	8.26	11.69	8.49	12.60	8.64	13.31	8.86
	110	9.50	7.65	10.21	8.18	10.92	8.01	11.44	8.24	12.35	8.40	13.07	8.62
115	9.25	7.42	9.96	7.95	10.67	7.80	11.19	8.03	12.10	8.20	12.82	8.42	
118	9.10	7.37	9.81	7.91	10.52	7.76	11.04	7.99	11.95	8.17	12.67	8.40	
122	9.05	7.35	9.76	7.89	10.48	7.74	10.99	7.98	11.90	8.16	12.62	8.39	

TC = Total Capacity (kBtu/h).

SHC: Sensible Heat Capacity (kBtu/h).

Nominal capacity as rated 0 ft. above sea level and a 0 ft. level difference between outdoor and indoor units. Corresponding refrigerant piping length is accordance with low length of each outdoor unit.

Nominal cooling capacity rating obtained with air entering the indoor unit at 80°F dry bulb (DB) and 67°F wet bulb (WB), and outdoor ambient conditions of 95°F dry bulb (DB) and 75°F wet bulb (WB).

The shaded table columns and rows indicate reference data. When operating at this temperature, these values can be different if the system is not running consistently.

Low Wall Console

# LOW WALL CONSOLE INDOOR UNITS

## Cooling Capacity Table

MULTI F  
MULTI F MAX

Table 27: Multi F Low Wall Console Indoor Units Cooling Capacity Table (continued).

Model No. / Nominal Capacity of Indoor Unit (Btu/h)	Outdoor Air Temp. (°F DB)	Indoor Air Temp. °F DB / °F WB											
		68 / 57		73 / 61		77 / 64		80 / 67		86 / 72		90 / 75	
		TC	SHC	TC	SHC	TC	SHC	TC	SHC	TC	SHC	TC	SHC
KNMQB151A 15,710	14	15.40	11.41	16.36	12.05	17.31	11.67	18.00	11.92	19.23	12.02	20.18	12.25
	20	15.39	11.50	16.34	12.15	17.30	11.76	17.99	12.01	19.21	12.11	20.17	12.34
	25	15.38	11.59	16.33	12.24	17.29	11.85	17.98	12.10	19.20	12.21	20.15	12.44
	30	15.37	11.68	16.32	12.34	17.27	11.94	17.96	12.20	19.18	12.30	20.14	12.53
	35	15.35	11.77	16.31	12.43	17.26	12.04	17.95	12.29	19.17	12.39	20.12	12.63
	40	15.34	11.86	16.29	12.52	17.25	12.13	17.94	12.38	19.15	12.49	20.11	12.72
	45	15.33	11.94	16.28	12.62	17.23	12.22	17.92	12.47	19.14	12.58	20.09	12.82
	50	15.32	12.03	16.27	12.71	17.22	12.31	17.91	12.57	19.12	12.67	20.07	12.91
	55	15.31	12.12	16.26	12.80	17.21	12.40	17.89	12.66	19.11	12.77	20.06	13.01
	60	15.29	12.21	16.24	12.90	17.19	12.49	17.88	12.75	19.09	12.86	20.04	13.10
	65	15.28	12.30	16.23	12.99	17.18	12.58	17.87	12.84	19.08	12.95	20.03	13.20
	70	15.27	12.38	16.22	13.08	17.17	12.67	17.85	12.93	19.06	13.04	20.01	13.29
	75	14.90	12.18	15.85	12.88	16.80	12.49	17.48	12.76	18.69	12.88	19.63	13.14
	80	14.54	11.97	15.48	12.68	16.42	12.31	17.11	12.59	18.31	12.72	19.25	12.99
	85	14.17	11.75	15.11	12.47	16.05	12.11	16.73	12.40	17.94	12.55	18.88	12.82
	90	13.81	11.53	14.75	12.25	15.69	11.92	16.36	12.21	17.56	12.37	18.50	12.65
	95	13.41	11.41	14.35	12.14	15.28	11.83	<b>15.71</b>	<b>11.94</b>	17.15	12.31	18.08	12.60
	100	13.09	11.10	14.02	11.83	14.95	11.55	15.51	11.75	16.82	12.04	17.76	12.34
105	12.76	10.80	13.69	11.53	14.63	11.26	15.30	11.57	16.50	11.78	17.43	12.08	
110	12.43	10.43	13.37	11.15	14.30	10.92	14.98	11.22	16.17	11.44	17.10	11.75	
115	12.11	10.12	13.04	10.84	13.97	10.63	14.65	10.94	15.84	11.17	16.78	11.48	
118	11.91	10.04	12.84	10.77	13.78	10.57	14.45	10.89	15.65	11.13	16.58	11.45	
122	11.84	10.02	12.78	10.75	13.71	10.55	14.39	10.87	15.58	11.12	16.52	11.44	

TC = Total Capacity (kBtu/h).

SHC: Sensible Heat Capacity (kBtu/h).

Nominal capacity as rated 0 ft. above sea level and a 0 ft. level difference between outdoor and indoor units. Corresponding refrigerant piping length is accordance with low length of each outdoor unit.

Nominal cooling capacity rating obtained with air entering the indoor unit at 80°F dry bulb (DB) and 67°F wet bulb (WB), and outdoor ambient conditions of 95°F dry bulb (DB) and 75°F wet bulb (WB).

The shaded table columns and rows indicate reference data. When operating at this temperature, these values can be different if the system is not running consistently.

Table 28: Multi F Low Wall Console Indoor Units Heating Capacity Table.

Model No. / Nominal Capacity of Indoor Unit (Btu/h)	Outdoor Air Temp.		Indoor Air Temp. °F DB					
	°F DB	°F WB	61	64	68	70	72	75
			TC	TC	TC	TC	TC	TC
KNUQB091A 9,000	0	-0.4	5.40	5.33	5.28	5.25	5.17	4.95
	5	4.5	6.09	6.01	5.96	5.93	5.86	5.63
	10	9	6.77	6.70	6.64	6.62	6.54	6.32
	17	15	7.68	7.61	7.56	<b>7.53</b>	7.46	7.21
	20	19	8.03	7.95	7.90	7.88	7.80	7.53
	25	23	8.60	8.52	8.47	8.45	8.37	8.07
	30	28	9.09	9.02	8.97	8.94	8.86	8.60
	35	32	9.59	9.51	9.46	9.43	9.36	9.13
	40	36	10.03	9.95	9.90	9.88	9.80	9.57
	45	41	10.47	10.40	10.35	10.32	10.25	10.02
	47	43	10.65	10.58	10.53	<b>10.50</b>	10.42	10.20
	50	46	10.82	10.75	10.70	10.67	10.60	10.34
	55	51	11.11	11.03	10.98	10.96	10.88	10.58
	60	56	11.11	11.03	10.98	10.96	10.88	10.62
	63	59	11.11	11.03	10.98	10.96	10.88	10.65
68	64	11.11	11.03	10.98	10.96	10.88	10.70	
KNUQB121A 12,000	0	-0.4	7.02	6.92	6.86	6.83	6.73	6.43
	5	4.5	7.91	7.81	7.75	7.72	7.62	7.32
	10	9	8.80	8.70	8.64	8.61	8.51	8.21
	17	15	9.99	9.89	9.83	<b>9.79</b>	9.69	9.38
	20	19	10.44	10.34	10.27	10.24	10.14	9.79
	25	23	11.18	11.08	11.01	10.98	10.88	10.48
	30	28	11.82	11.72	11.66	11.62	11.52	11.18
	35	32	12.46	12.36	12.30	12.27	12.17	11.87
	40	36	13.04	12.94	12.88	12.84	12.74	12.45
	45	41	13.62	13.52	13.45	13.42	13.32	13.02
	47	43	13.85	13.75	13.68	<b>13.65</b>	13.55	13.25
	50	46	14.07	13.97	13.91	13.87	13.77	13.44
	55	51	14.44	14.34	14.28	14.24	14.14	13.75
	60	56	14.44	14.34	14.28	14.24	14.14	13.81
	63	59	14.44	14.34	14.28	14.24	14.14	13.85
68	64	14.44	14.34	14.28	14.24	14.14	13.91	
KNMQB151A 15,710	0	-0.4	8.78	8.66	8.58	8.54	8.41	8.04
	5	4.5	9.90	9.77	9.69	9.65	9.52	9.15
	10	9	11.01	10.89	10.80	10.76	10.64	10.27
	17	15	12.49	12.37	12.29	<b>12.25</b>	12.12	11.73
	20	19	13.05	12.93	12.84	12.80	12.68	12.25
	25	23	13.98	13.85	13.77	13.73	13.61	13.11
	30	28	14.78	14.66	14.58	14.53	14.41	13.98
	35	32	15.59	15.46	15.38	15.34	15.21	14.84
	40	36	16.31	16.18	16.10	16.06	15.94	15.57
	45	41	17.03	16.91	16.82	16.78	16.66	16.29
	47	43	17.32	17.19	17.11	<b>17.07</b>	16.95	16.58
	50	46	17.60	17.47	17.39	17.35	17.22	16.81
	55	51	18.06	17.94	17.85	17.81	17.69	17.19
	60	56	18.06	17.94	17.85	17.81	17.69	17.27
	63	59	18.06	17.94	17.85	17.81	17.69	17.32
68	64	18.06	17.94	17.85	17.81	17.69	17.39	

TC = Total Capacity (kBtu/h).

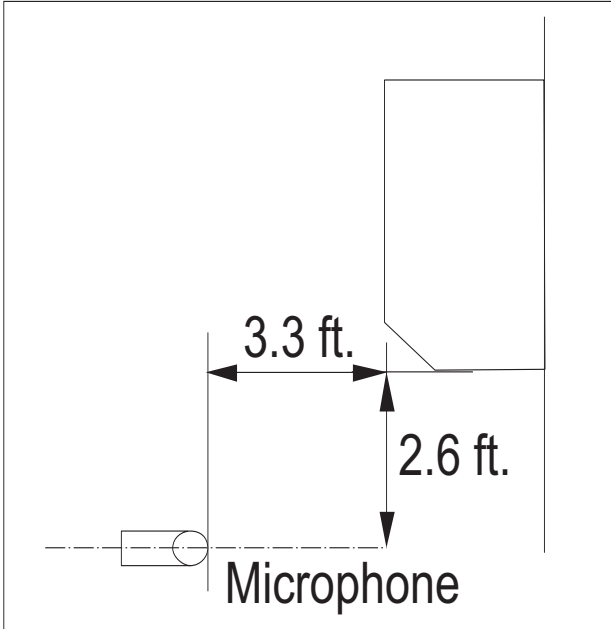
Nominal capacity as rated 0 ft. above sea level and a 0 ft. level difference between outdoor and indoor units. Corresponding refrigerant piping length is accordance with low length of each outdoor unit. Nominal heating capacity rating obtained with air entering the indoor unit at 70°F dry bulb (DB) and 60°F wet bulb (WB), and outdoor ambient conditions of 47°F dry bulb (DB) and 43°F wet bulb (WB).

# LOW WALL CONSOLE INDOOR UNITS

## Acoustic Data

MULTI F  
MULTI F MAX

Figure 66: Sound Pressure Level Measurement Location.



- Measurement taken 2.6' below the bottom of the unit and at a distance of 3.3' from face of unit.
- Measurements taken with no attenuation and units operating at full load normal operating condition.
- Sound level will vary depending on a range of factors such as construction (acoustic absorption coefficient) of particular area in which the equipment is installed.
- Sound power levels are measured in dB(A).
- Tested in anechoic chamber per ISO Low 3745.

Table 29: Sound Pressure Levels (dB[A]).

Model No.	Sound Pressure Levels (dB[A]) (Cooling and Heating)		
	High Fan Speed	Medium Fan Speed	Low Fan Speed
KNUQB091A	38	32	27
KNUQB121A	39	32	27
KNMQB151A	44	39	35

Figure 67: KNUQB091A and KNUQB121A Sound Pressure Level Diagrams.

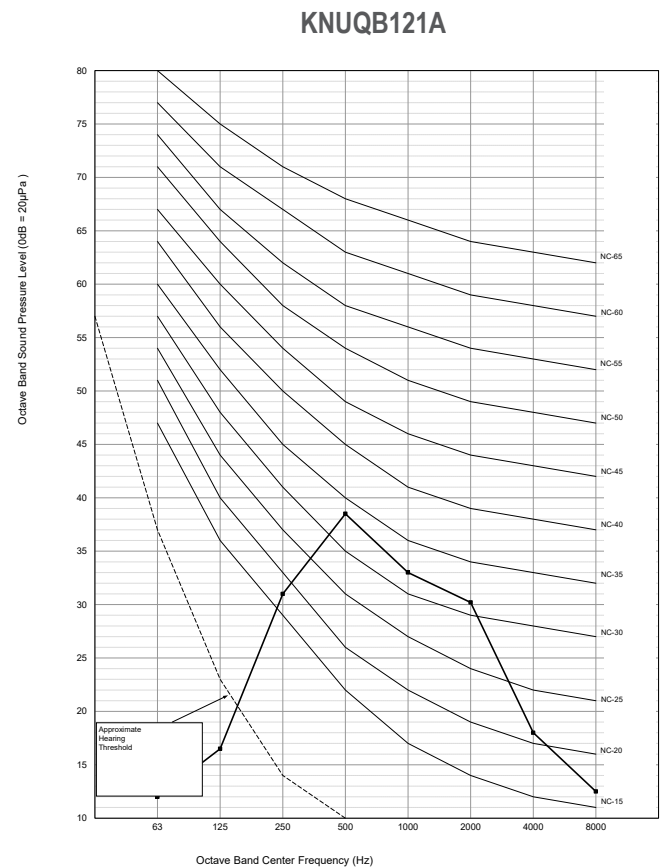
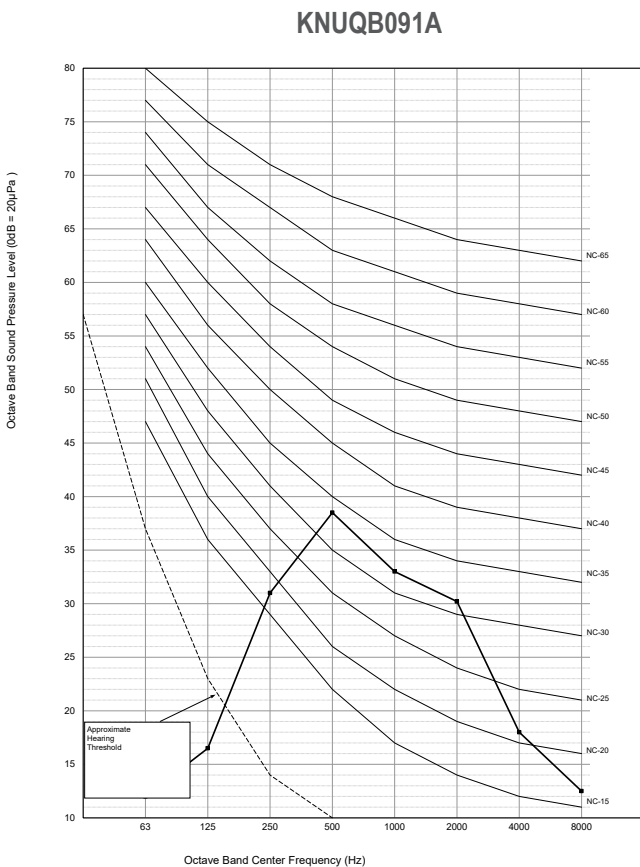
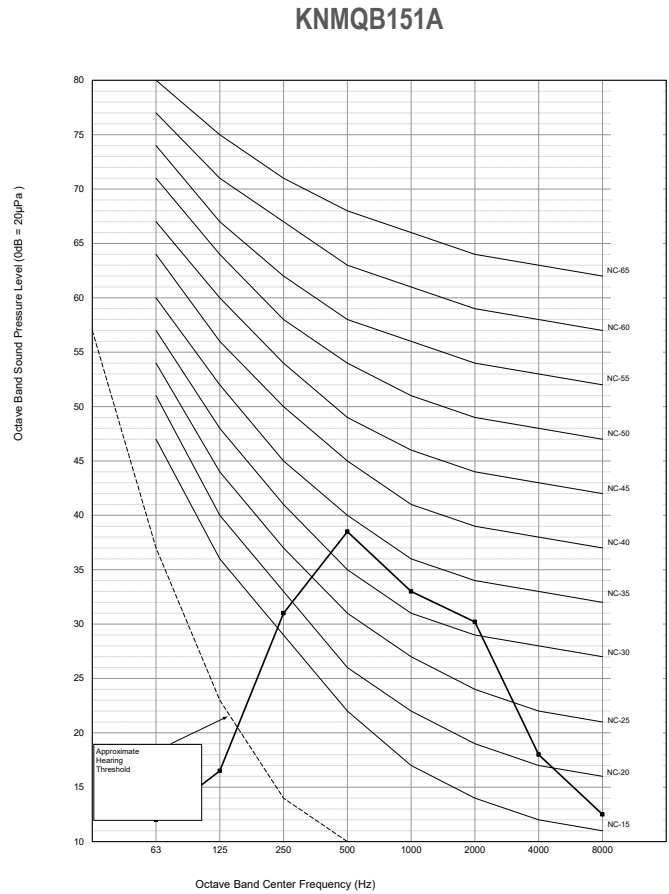


Figure 68: KNMQB151A Sound Pressure Level Diagram.



# LOW WALL CONSOLE INDOOR UNITS

## Air Velocity and Temperature Distribution

MULTI F  
MULTI F MAX

Figure 69: KNUQB091A and KNUQB121A Air Velocity and Temperature Distribution Charts.

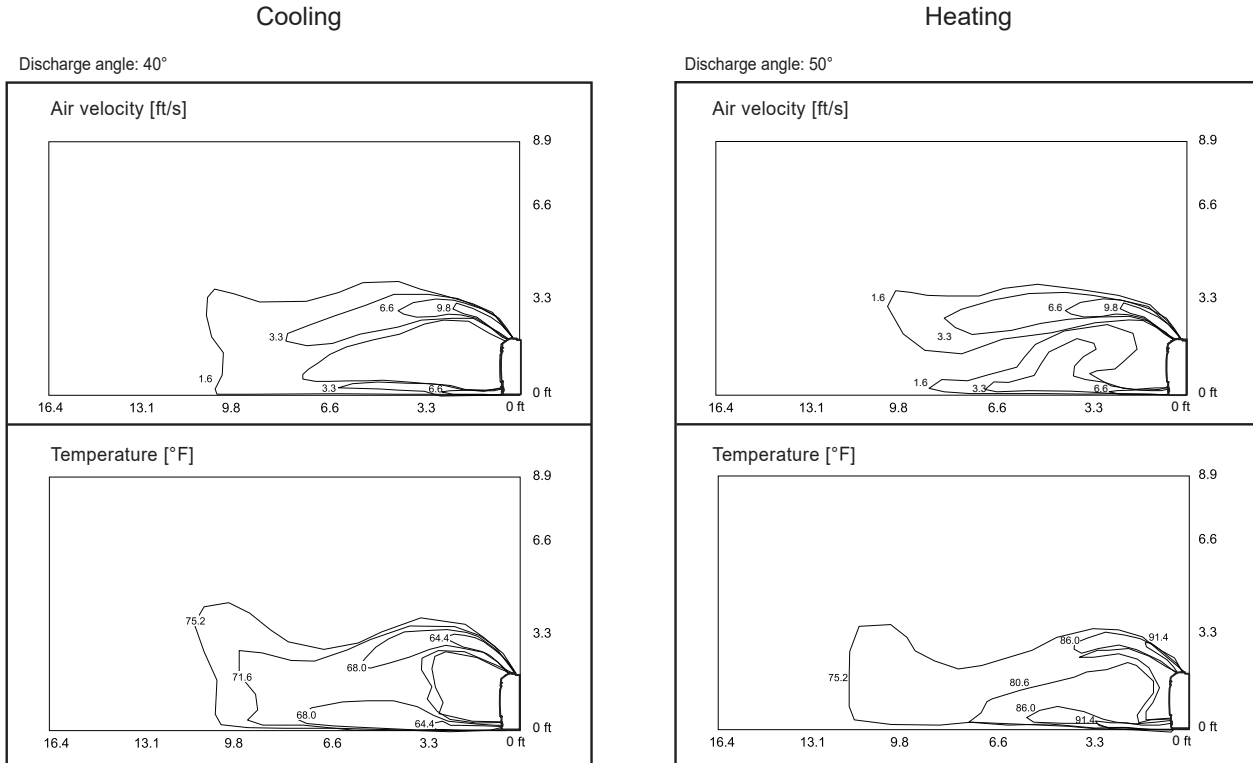


Figure 70: KNMQB151A Air Velocity and Temperature Distribution Charts.

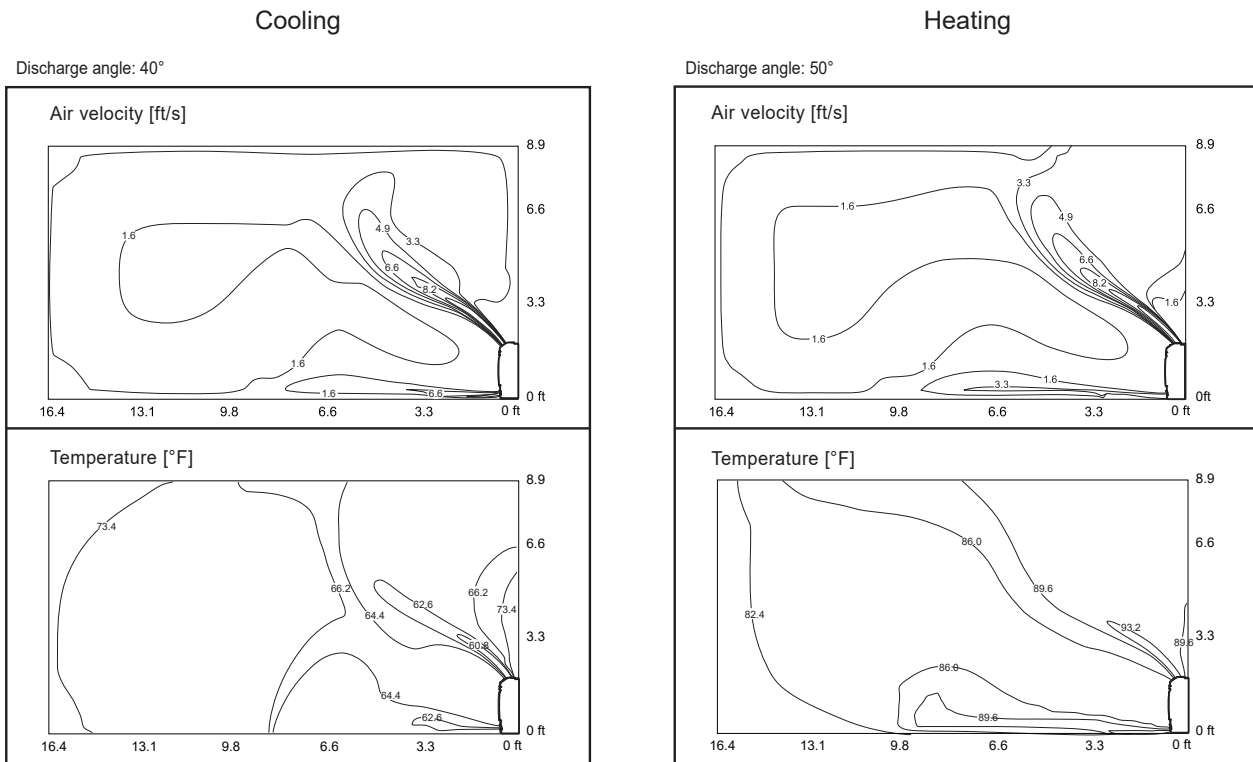


Figure 71: Multi F Low Wall Console Indoor Unit Refrigerant Flow Diagram.

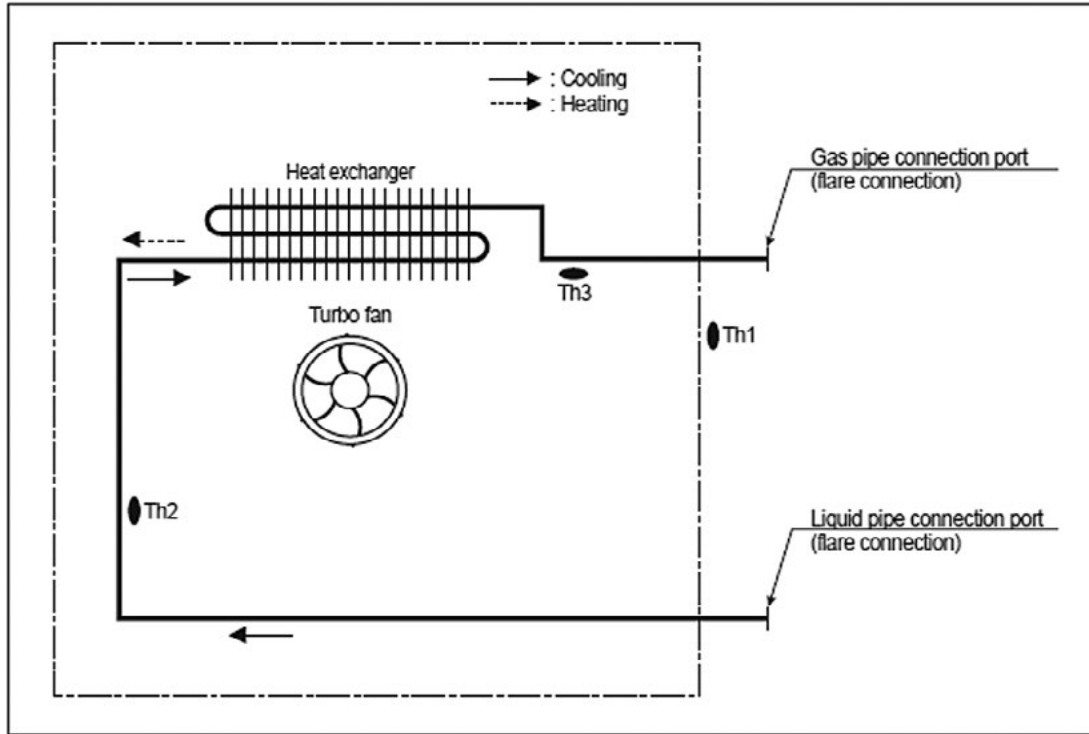


Table 30: Multi F Low Wall Console Indoor Unit Thermistor Details

Thermistor	Description	PCB Connector
Th1	Suction air temperature	CN_ROOM
Th2	Evaporator inlet temperature	CN_PIPE_IN
Th3	Evaporator outlet temperature	CN_PIPE_Out

Table 31: Multi F Low Wall Console Indoor Unit Refrigerant Pipe Sizes

Model	Vapor (inch)	Liquid (inch)
KNUQB091A	φ3/8	φ1/4
KNUQB121A		
KNMQB151A	φ1/2	

Table 32: Multi F Low Wall Console Indoor Unit Refrigerant Pipe Connections

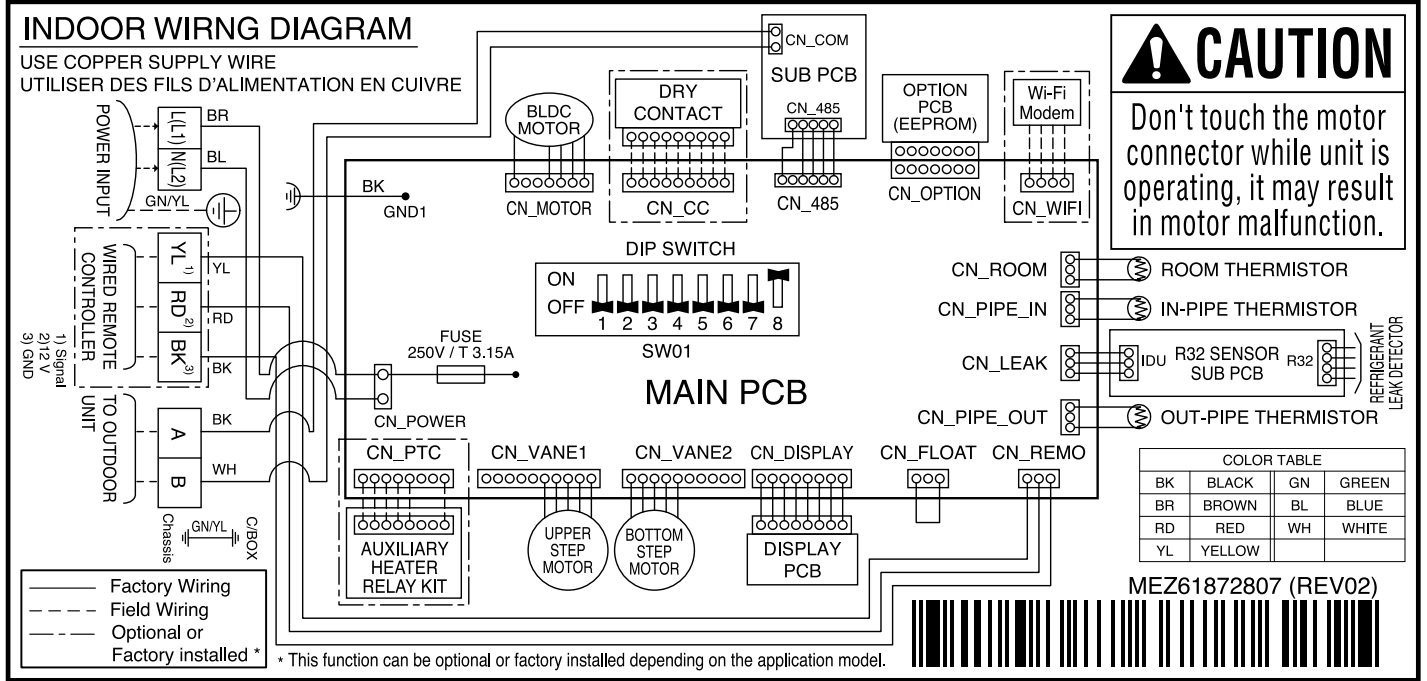
Model	Vapor (inch)	Liquid (inch)
KNUQB091A	φ3/8	φ1/4
KNUQB121A		
KNMQB151A	φ1/2	

# LOW WALL CONSOLE INDOOR UNITS

## Wiring Diagram

MULTI F  
MULTI F MAX

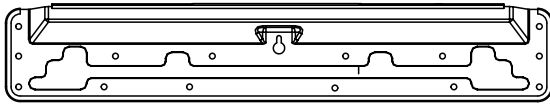
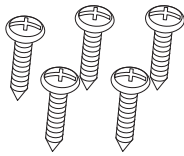
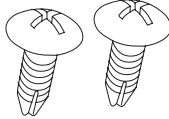

Figure 72: Multi F Low Wall Console KNUQB091A, KNUQB121A, and KNMQB151A Indoor Units Wiring Diagram.



Multi F and Multi F MAX Indoor Unit Engineering Manual

## Factory Supplied Parts

Table 33: Parts Table.

Part	Quantity	Image
Installation Plate	One (1)	
Type "A" Screws	Five (5)	
Type "B" Screws (M4 x 12L)	Two (2)	
Wireless Controller with Holder AKB75735427	One (1)	

## Factory Supplied Materials

- Owner's Manual
- Installation Manual

## Required Tools

- Level
- Screwdriver
- Electric drill
- Hole core drill
- Flaring tool set
- Spanner (Half union)
- Thermometer

### **⚠ WARNING**

Installation work must be performed by trained personnel and in accordance with national wiring laws and all local or other applicable codes. Improper installation can result in fire, electric shock, physical injury, or death.

### **NOTICE**

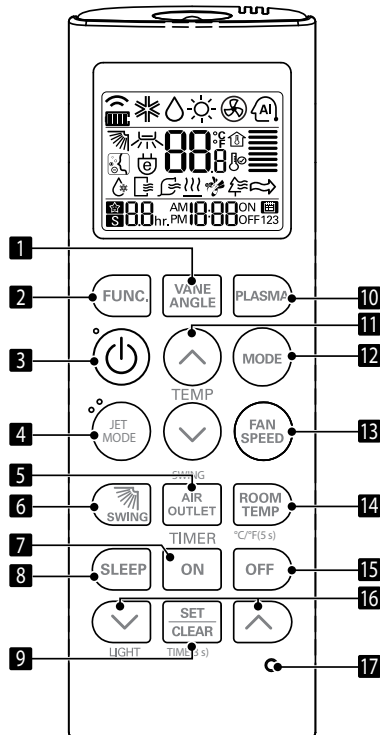
Read all instructions before installing this product. Become familiar with the unit's components and connections, and the order of installation. Incorrect installation can degrade or prevent proper operation.

# LOW WALL CONSOLE INDOOR UNITS

Factory Supplied Parts and Materials

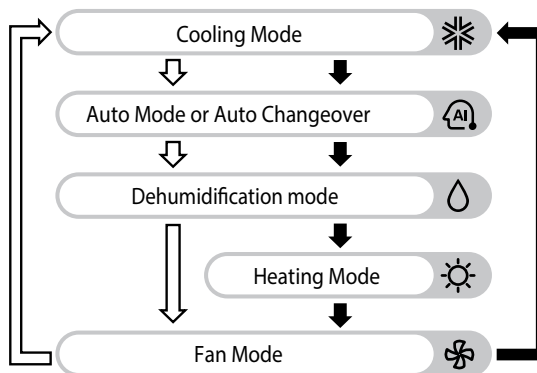
MULTI F  
MULTI F MAX

## Wireless Handheld Controller



- 1** VANE ANGLE Button  
Used to set each vane angle.
- 2** FUNCTION SETTING Button  
Used to set or clear Auto Clean, Smart Clean, Electric heater or Individual vane angle control.
- 3** ON/OFF Button  
Used to turn on/off the unit.
- 4** JET MODE Button  
JET MODE sets the fan to operate at a super high speed.
- 5** AIR OUTLET Button  
Used to select airflow direction
- 6** UP/DOWN AIRFLOW Button  
Used to stop or start louver movement and set the desired up/down airflow direction.
- 7** ON TIMER Button  
Used to set the time of starting operation.
- 8** SLEEP TIMER Button  
Used to set the time of sleeping operation.
- 9** SET / CLEAR Button  
Used to set/clear the timer.  
Used to set the current time (if it input for 3sec.)
- 10** PLASMA Button (OPTIONAL)  
Used to start or stop the plasma-purification function.
- 11** ROOM TEMPERATURE SETTING Button  
Used to select the room temperature.
- 12** OPERATION MODE SELECTION Button  
Used to select the operation mode.
- 13** INDOOR FAN SPEED SELECTION Button  
Used to select fan speed in four steps low, medium, high and chaos.
- 14** ROOM TEMPERATURE CHECKING Button  
Used to check the room temperature.
- 15** OFF TIMER Button  
Used to set the time of stopping operation.
- 16** TIMER SETTING (Up/Down)/LIGHT Button  
Used to set the timer.  
Used to adjust the brightness. (If it is not time adjust mode)
- 17** RESET Button  
Used to reset the remote controller.

### Operation Mode



Cooling Model (↕)  
Heat Pump Model (⇓)

### Selecting the Best Location

#### Do's

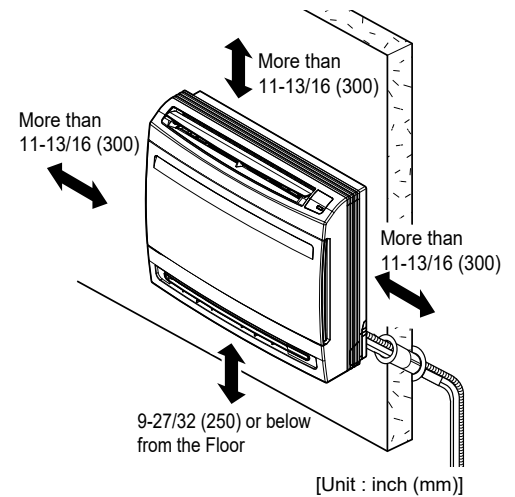
- Place the unit where air circulation will not be blocked.
- Place the unit where drainage can be obtained easily.
- Place the unit where noise prevention is taken into consideration.
- Ensure there is sufficient space from the ceiling and floor.
- Ensure there is sufficient maintenance space.
- Locate the indoor unit where it can be easily connected to the outdoor unit or branch distribution unit.

#### Don'ts

- Do not install the unit near a heat or steam source, or where considerable amounts of oil, iron powder, or flour are used.
- Do not install the unit where sulfuric acid and flammable or corrosive gases are generated, vented into, or stored.
- Do not install the unit near high-frequency generators.
- Do not install the unit near a doorway.

The unit will be damaged, will malfunction, and / or will not operate as designed if installed in any of the conditions listed.

Figure 73: Minimum Clearance Requirements.



### NOTICE

- Indoor units (IDUs) must not be placed in an environment where the IDUs will be exposed to harmful volatile organic compounds (VOCs) or in environments where there is improper air make up or supply or inadequate ventilation. If there are concerns about VOCs in the environment where the IDUs are installed, proper air make up or supply and/or adequate ventilation must be provided. Additionally, in buildings where IDUs will be exposed to VOCs, consider a third party factory-applied epoxy coating to the fan coils for each IDU where the entire coil is dipped, not sprayed.
- If the unit is installed near a body of water, the installation parts are at risk of corroding. Appropriate anti-corrosion methods must be taken for the unit and all installation parts.

### Installing in an Area Exposed to Unconditioned Air

In some installation applications, areas (floors, walls) in some rooms will be exposed to unconditioned air (room will be above or next to an unheated garage or storeroom). To countermeasure:

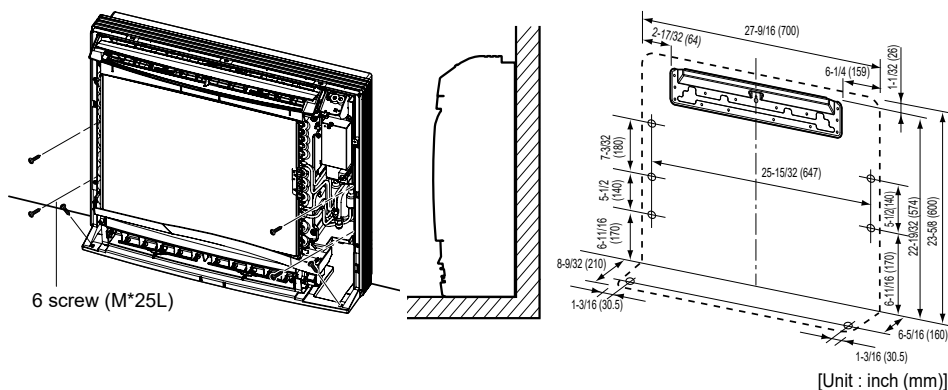
- Verify that carpet is or will be installed (carpet will increase the temperature by three degrees).
- Add insulation between the floor joists.
- Install radiant heat or another type of heating system to the floor.

### Selecting Installation Method

The unit can be installed in one of three configurations:

- On the floor.
- Mounted on the wall above floor molding.
- Half concealed (recessed) in an opening in the wall.

Figure 74: Floor Installation



### NOTICE

If the unit is installed near a body of water, certain components are at risk of being corroded. Appropriate anti-corrosion methods must be taken for the unit and all components.

Figure 75: Wall Installation.

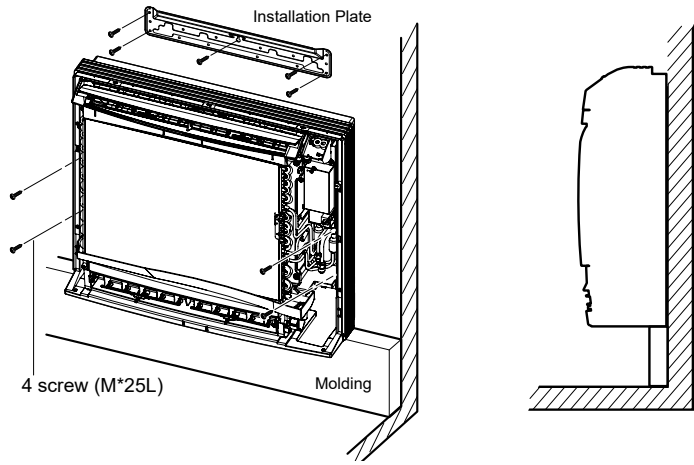
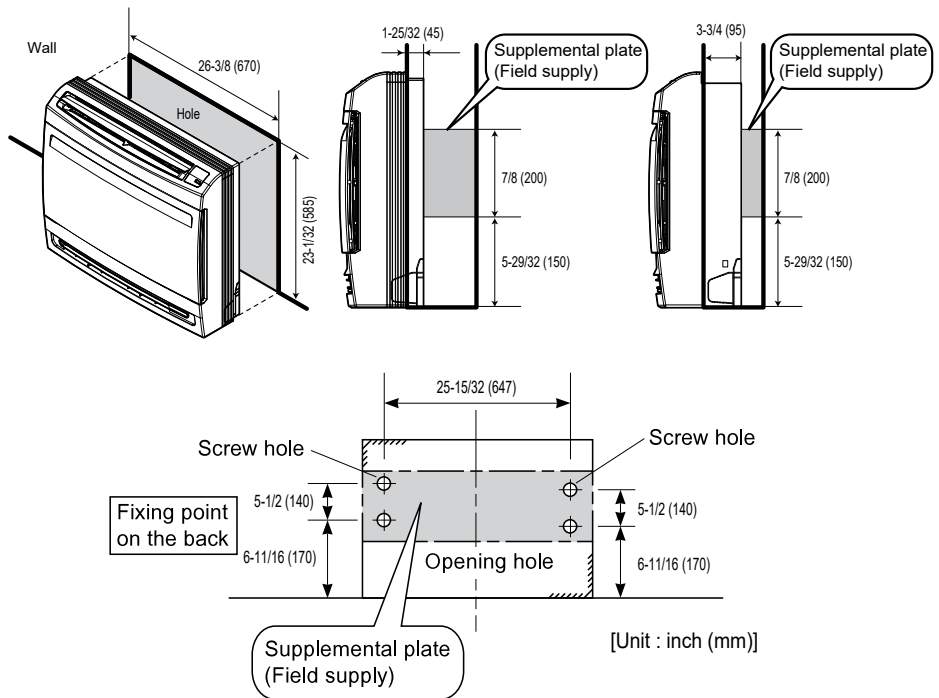


Figure 76: Recessed Installation.



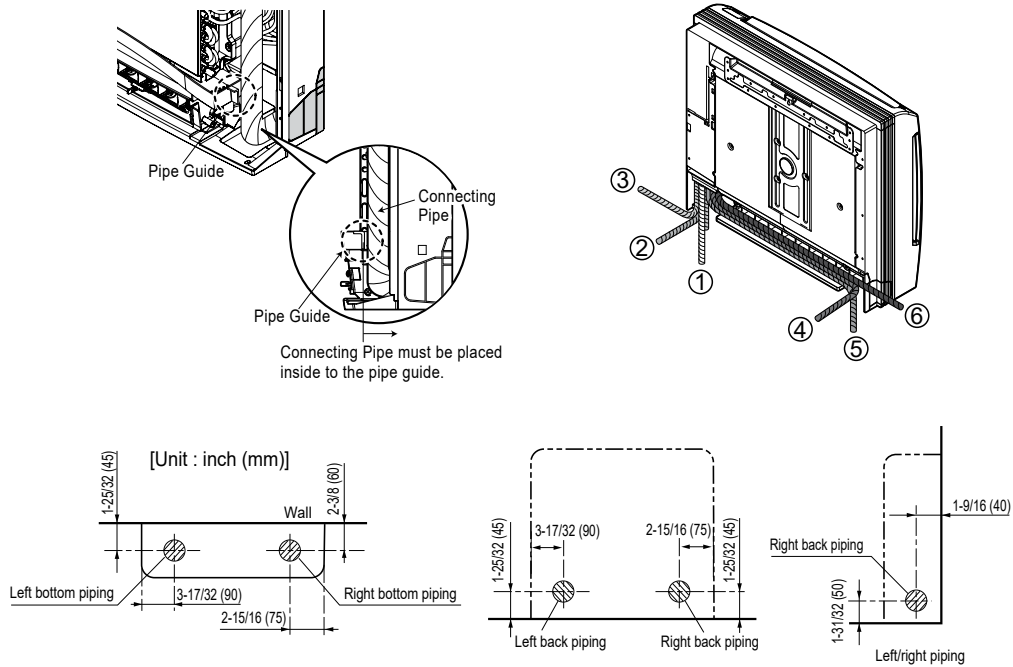
### Mounting the Installation Plate

- The mounting wall must be strong and solid enough to protect the unit from vibration.
- Mount the installation plate on the wall using the Type "A" screws. If mounting the unit on concrete, consider using anchor bolts.
  - Always mount the installation plate horizontally. Measure the wall and mark the centerline using thread and a level.

## Selecting Pipe Routing

The pipe can be routed in one of six directions as shown in Figure 77.

Figure 77: Pipe Holes and Routing.

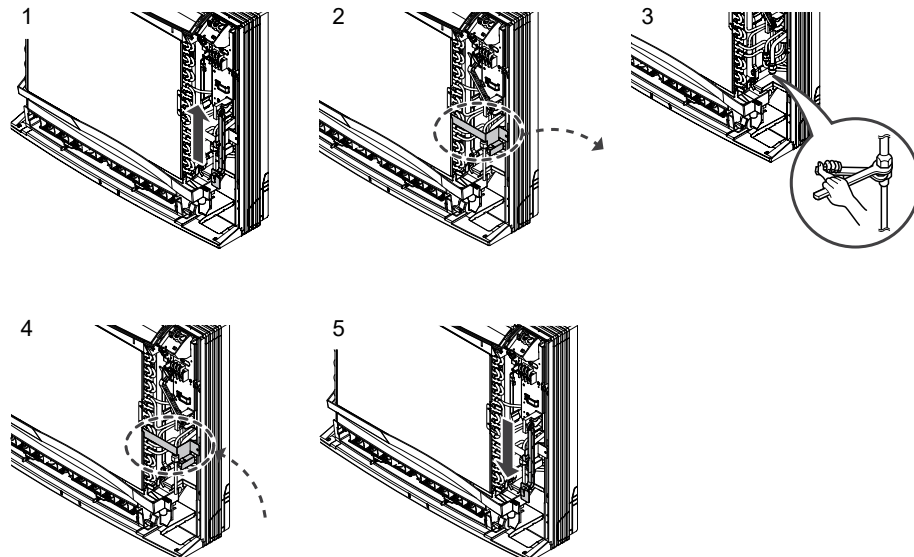


## Pipe Connection

Connect the pipes as shown in Figure 78

1. Hold up the Sensor Link.
2. Separate the Pipe Bracket (2 screws)
3. Connect the refrigerant pipe. (Refer to next page)
4. Assemble the Pipe Bracket (2 screws)
5. Put down the Sensor Link.

Figure 78: Pipe Connection.



# LOW WALL CONSOLE INDOOR UNITS

## Installation and Best Layout Practices

MULTI F  
MULTI F MAX

### Pipe Routing and Insulation

#### NOTICE

If the drain hose is routed inside the room insulate the hose with an insulation material\* so that dripping from sweating (condensation) will not damage furniture or floors.

\* Foamed polyethylene or equivalent is recommended.

Connecting the installation pipe and drain hose to the indoor unit.

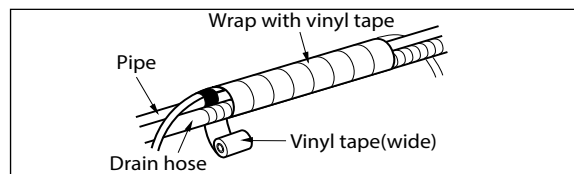
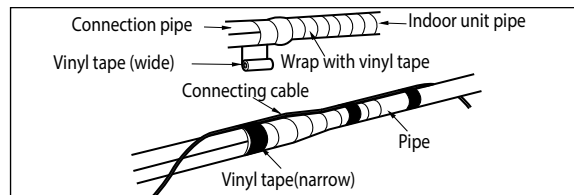
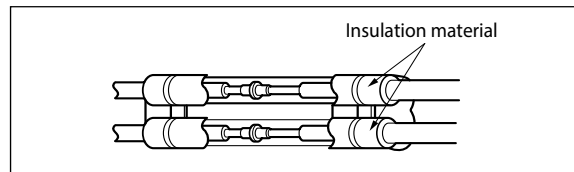
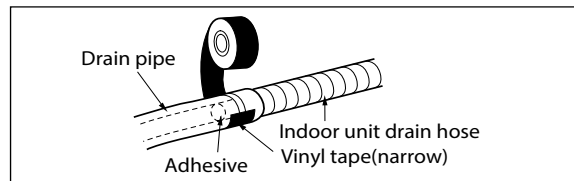
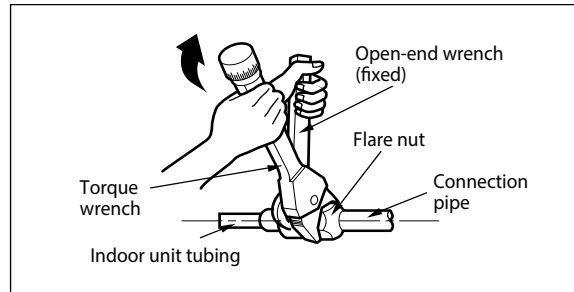
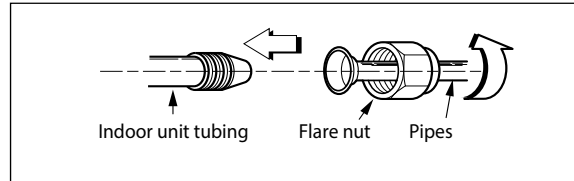
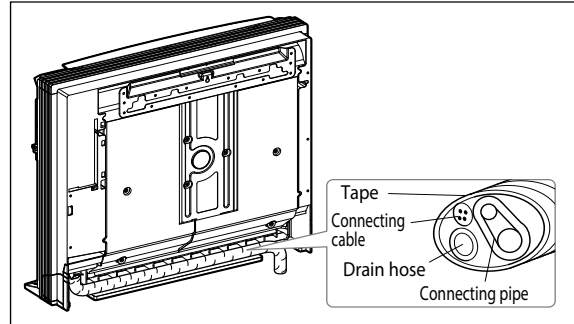
1. Align the center of the pipes and sufficiently tighten the flare nut by hand.
2. Tighten the flare nut with a wrench.

Piping Size		Torque		
mm	inch	kgf-cm	N-m	lbf-ft
Ø 6.35	Ø 1/4	180 ~ 250	17.6 ~ 24.5	13 ~ 18
Ø 9.52	Ø 3/8	340 ~ 420	33.3 ~ 41.2	25 ~ 30
Ø 12.7	Ø 1/2	550 ~ 660	53.9 ~ 64.7	40 ~ 48
Ø 15.88	Ø 5/8	630 ~ 820	61.7 ~ 80.4	45 ~ 59
Ø 19.05	Ø 3/4	990 ~ 1,210	97.0 ~ 118.7	71 ~ 87

3. When needed to extend the drain hose of indoor unit, assemble the drain pipe as shown on the drawing.

Wrap the insulation material around the connecting portion.

1. Overlap the connection pipe insulation material and the indoor unit pipe insulation material. Bind them together with vinyl tape so that there may be no gap.
2. Wrap the area which accommodates the rear piping housing section with vinyl tape.
3. Bundle the piping and drain hose together by wrapping them with vinyl tape sufficient enough to cover where they fit into the rear piping housing section.



### Power Wiring / Communications Cable Guidelines

- Follow manufacturer's circuit diagrams in the technical manuals.
- Confirm power source specifications.
- Confirm that the electrical capacity is sufficient.
- Starting current must be maintained  $\pm 10$  percent of the rated current marked on the outdoor unit name plate.
- Confirm cable thickness specifications.
- It is required that a circuit breaker is installed, especially if conditions could become wet or moist.
- Include a disconnect in the power wiring system, add an air gap contact separation of at least 1/8 inch in each active (phase) conductor.

### ⚠ WARNING

- Loose wiring will cause unit to malfunction, overheat, and catch fire, resulting in severe injury or death.

### NOTICE

- Terminal screws will become loose during transport. Properly tighten the terminal connections during installation.
- A voltage drop will cause the following problems:
  - Magnetic switch vibration, fuse breaks, or disturbance to the normal function of an overload protection device.
  - Compressor will not receive the proper starting current.

### Connect Power Wiring and Communications Cable

1. Insert the power wiring / communications cable from the outdoor unit or branch distribution unit (Multi F MAX systems only).
2. Remove screws 1 and 2 and remove control box cover.
3. Connect each wire to its appropriate terminal on the indoor unit control board. Verify that the color and terminal numbers from the outdoor unit or branch distribution unit (Multi F MAX systems only) wiring match the color and terminal numbers on the indoor unit.
4. Secure power wiring/communications cable with cable restraint.

Figure 80: Simplified View of Indoor Unit to Outdoor Unit / Branch Distribution Unit Terminal Connections

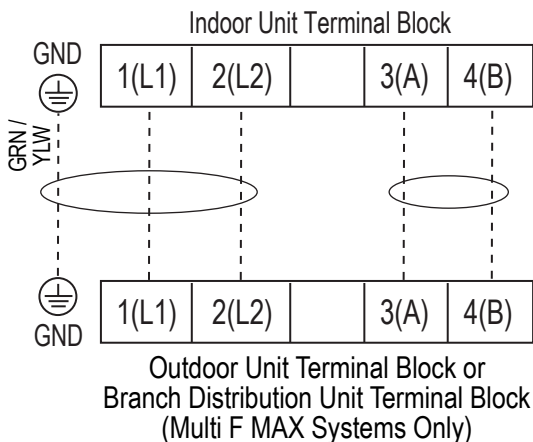


Figure 79: Connecting Power Wiring / Communications Cable.

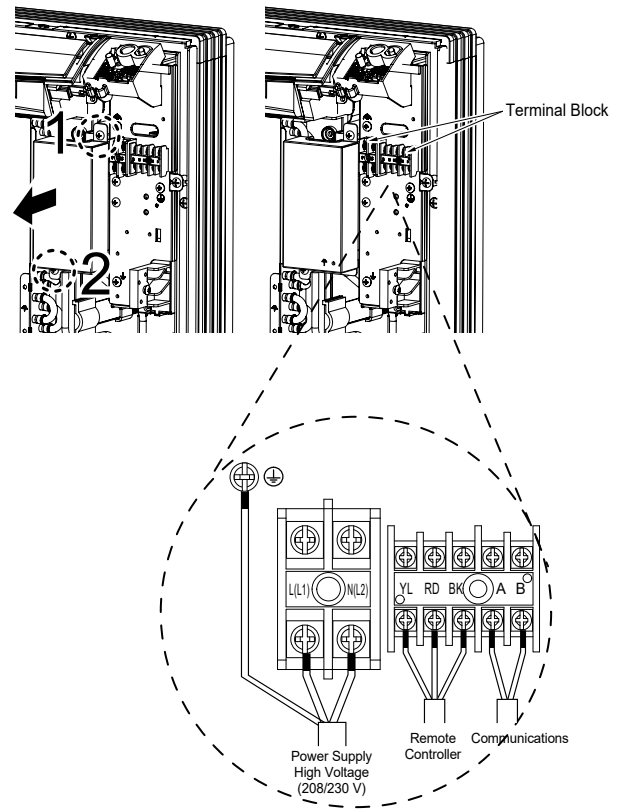
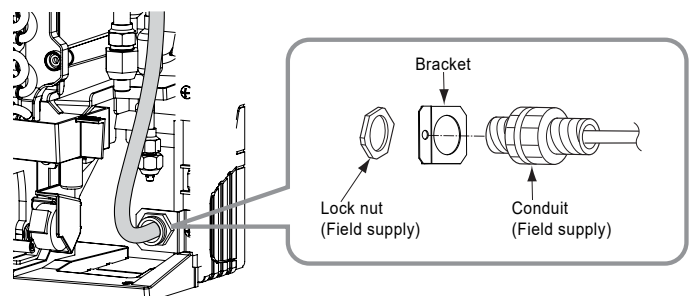


Figure 81: Securing Wiring to Unit.



# LOW WALL CONSOLE INDOOR UNITS

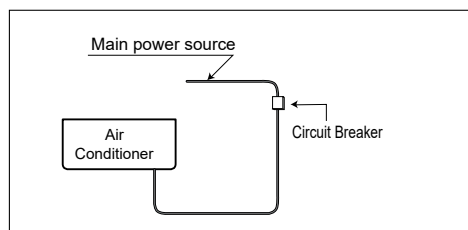
## Installation and Best Layout Practices

MULTI F  
MULTI F MAX

### Power Connection

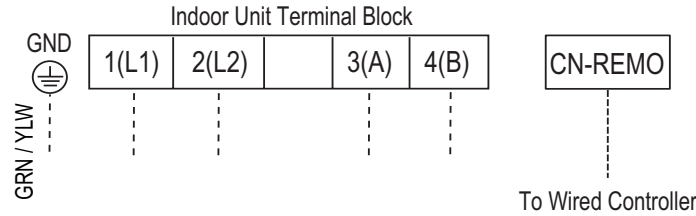
1. All wiring must comply with applicable code.
2. Select a power source that is capable of supplying the current required by the air conditioner.
3. Feed the power source to the unit via a distribution switch board designed for this purpose.
4. The terminal screws inside the control box may be loose due to vibration during transport. Check the screws for loose connection. (Running the air conditioner with loose connection can overload and damage electrical components.)
5. Always ground the air conditioner with a grounding wire and connector to meet applicable code.

Figure 82: Power Wiring.



### Wired Controller Connections

Figure 83: Wired Controller Connection on Indoor Unit Terminal Block.

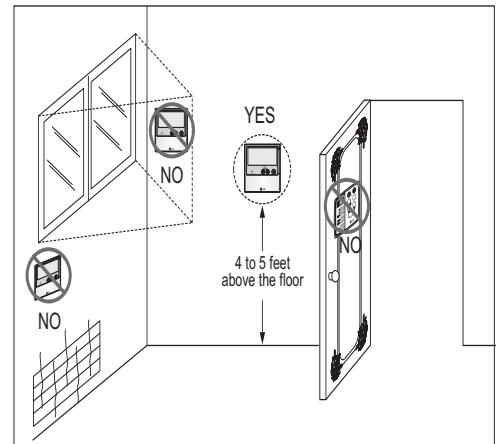


### Wired Controller Placement

Wired controllers include a sensor to detect room temperature. To maintain comfort levels in the conditioned space, the wired controller must be installed in a location away from direct sunlight, high humidity, and where it could be directly exposed to cold air. Controller must be installed four (4) to five (5) feet above the floor where its LED display can be read easily, in an area with good air circulation, and where it can detect an average room temperature.

- ⊘ Do not install the wired controller near or in:
  - Drafts or dead spots behind doors and in corners
  - Hot or cold air from ducts
  - Radiant heat from the sun or appliances
  - Concealed pipes and chimneys
  - An area where temperatures are uncontrolled, such as an outside wall

Figure 84: Proper Location for the Wired Controller.



# LOW WALL CONSOLE INDOOR UNITS

## Installation and Best Layout Practices

MULTI F  
MULTI F MAX

### Hanging the Wired Controller

1. The controller wiring / cable can be installed in one of three directions: top, back, or on the right side. If top or right side installation is desired, remove cable guide grooves on the controller, and then position wiring / cable on applicable side.
2. Choose and mark the area of installation. Use the provided parts and screw the wall plate into place. Install the controller wall plate to fit the electrical box if one is present. Ensure that no gaps exist between the wall plate and the wall itself.
3. Arrange wiring / cables so as not to interfere with the controller circuitry. Position the wired controller on the wall plate. Snap into place by pressing the bottom part of the wired controller onto the wall plate. Make sure that no gaps exist between the wired controller and the wall plate on all sides.
4. To remove wired controller from the wall plate, insert a screwdriver into the two holes at the bottom. Twist screwdriver to release controller. ⚠ Do not damage the controller components when removing.

Figure 85: Removing the Cable Guide Grooves.

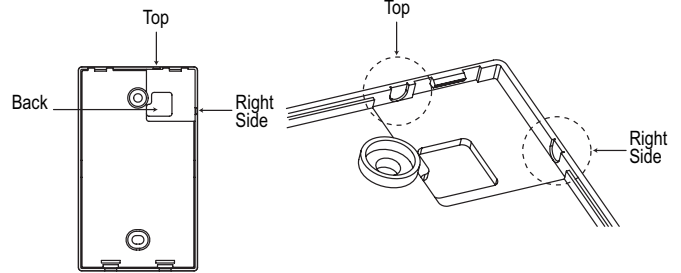


Figure 86: Attaching the Wall Plate.

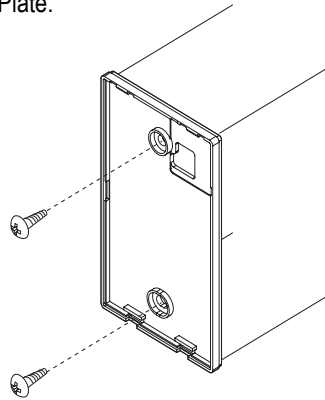
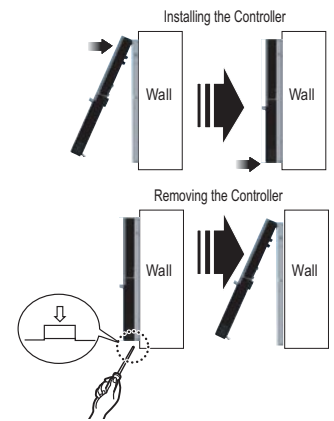


Figure 87: Installing / Removing the Controller.



### Assigning the Thermistor for Temperature Detection

Each indoor unit includes a return air thermistor assigned to sense the temperature. If a wired controller is installed, there is a choice of sensing temperature with either the indoor unit return air thermistor or the thermistor in the wired controller. It is also an option to set both thermistors to sense temperature so that indoor unit bases its operation on the first thermistor to reach the designated temperature differential. For applicable indoor units, an optional Remote Temperature Sensor can be used in lieu of the return air thermistor—either alone or in conjunction with a wired controller thermistor as previously described.

# LOW STATIC DUCT INDOOR UNIT DATA

**Mechanical Specifications on page 76**

**General Data / Specifications on page 77**

**Dimensions on page 78**

**Cooling Capacity Table on page 79**

**Heating Capacity Table on page 81**

**External Static Pressure on page 82**

**Acoustic Data on page 83**

**Refrigerant Flow Diagrams on page 84**

**Wiring Diagram on page 86**

**Factory Supplied Parts and Materials on page 88**

**Installation and Best Layout Practices on page 89**

# LOW STATIC DUCT INDOOR UNITS

## Mechanical Specifications and Features

MULTI F  
MULTI F MAX

### Low Static Duct Indoor Unit

#### General

All LG indoor units are factory assembled, wired, piped, and provided with a control circuit board, fan, and motor. Low Static Duct units have a sound rating no higher than 36 dB(A) as tested per KSA0701 ISO Standard 3745, and are designed for low-static pressure up to 0.20"WG.

#### Coil

Indoor unit coils are factory built and are comprised of aluminum fins mechanically bonded to copper tubing. Each unit has two rows of coils, which are pressure tested at the factory. Each unit is provided with a factory installed condensate drain pan below the coil.

#### Refrigerant System

System is designed for use with R32 refrigerant. The refrigeration circuit is pressure-tested at the factory and shipped with a holding charge of helium gas. Refrigerant pipe connections are 45° flare, and all refrigerant lines from the outdoor unit to the indoor units must be field insulated.

#### Electrical

Each indoor unit is designed to operate using 208–230/60/1 power with voltage variances of  $\pm 10\%$ .

#### Casing

The case has a low profile design with a maximum height of 7.5 inches designed to mount fully concealed above a finished ceiling in as little as 8 inches vertical space. Casing is manufactured of galvanized steel plate, and provided with hanger brackets designed to support the weight on four corners. Unit has a front horizontal supply air discharge outlet, and one rear horizontal return air inlet; unit is also field-convertible for a rear bottom return.

#### Fan Assembly and Control

The units have at least two direct-drive, Sirocco fans made of high strength ABS HT-700 polymeric resin that are statically and dynamically balanced. The fans are mounted on a common brushless digitally controlled (BLDC) motor with permanently lubricated and sealed ball bearings. The fan / motor assembly is mounted on vibration-attenuating rubber grommets. Fan speed is controlled using a microprocessor-based direct digital control algorithm. The indoor fan has Low, Med, High, and Auto settings for Cooling mode; and has Low, Med, High, and Auto settings for Heating mode. Each of the settings can be field-adjusted from the factory setting (RPM / ESP). The Auto setting adjusts the fan speed based on the difference between the controller set-point and space temperature.

### Features

- Inverter (Variable speed fan)
- External mounted drain pump
- Control lock function
- Auto operation
- Auto restart operation
- Dehumidification function
- Two thermistor control
- External static pressure control
- Self-diagnostics function
- Group control
- Wired controller ordered separately
- Wi-Fi compatible

Figure 88: Low Static Duct Indoor Unit.



#### Air Filter

Return air is filtered with a factory-supplied, removable, washable filter accessible from the rear of the indoor unit.

#### Microprocessor Control

The unit is provided with an integrated control panel to communicate with the outdoor unit. All unit operation parameters are stored in non-volatile memory residing on the unit microprocessor. The microprocessor controls space temperature through using the value provided by the temperature sensor within the indoor unit. The microprocessor control will activate indoor unit operation when the indoor room temperature falls below or rises above a setpoint temperature, at which point, a signal is sent to the outdoor unit to begin the appropriate mode. The microprocessor will also provide self-diagnostics and auto restart functions. A field-supplied three-wire power cable (3 x 14 AWG) and two-wire communications cable (2 x 18 AWG) must be installed to connect the indoor unit(s) to the outdoor unit.

The indoor units are Wi-Fi compatible with the addition of an LG Wi-Fi module accessory, and can be controlled by LG's Smart ThinQ™ app on a smart device. A field-supplied Wi-Fi network and smart device are required. The Smart ThinQ app is free, and is available for Android™ and iOS. (Android is a trademark of Google LLC.)

#### Controls

The indoor unit controller of choice must be ordered separately. Communication between the indoor units and the outdoor unit is accomplished through 18 AWG, two-core, stranded and shielded communication cable.

#### Condensate Lift/Pump

The indoor unit is provided with a factory installed and wired condensate lift/pump capable of providing a minimum 27.5 inch lift from the bottom surface of the unit. Drain pump has a safety switch to shut off the indoor unit if the condensate rises too high in the drain pan.

Table 34: Multi F Low Static Duct Indoor Unit General Data.

Model Name	KNMKB091A	KNMKB121A	KNMKB181A
Nominal Cooling Capacity (Btu/h) <sup>1</sup>	9,000	12,000	18,000
Nominal Heating Capacity (Btu/h) <sup>1</sup>	10,400	13,800	20,800
<i>Operating Range</i>			
Cooling (°F WB)	57-77		
Heating (°F DB)	59-81		
Fan			
Type	Sirocco		
Motor Output (W) x Qty.	19 x 1	5 x 1, 19 x 1	
Motor/Drive	Brushless Digitally Controlled / Direct		
Airflow Rate CFM (H/M/L)	318 / 247 / 194	353 / 300 / 247	530 / 441 / 353
Factory Set External Static Pressure (in. wg)	0.10		
Min. External Static Pressure (in. wg)	0.00		
Max. External Static Pressure (in. wg)	0.20		
<i>Unit Data</i>			
Refrigerant Type <sup>2</sup>	R32		
Refrigerant Control	EEV		
Power Supply V, Ø, Hz <sup>3</sup>	208-230, 1, 60		
Rated Amps (A)	0.40	0.80	
Sound Pressure Level dB(A) (H/M/L) <sup>4</sup>	30 / 26 / 23	31 / 28 / 27	36 / 34 / 31
Sound Power Level dB(A)	49	52	54
Dimensions (W x H x D, in.)	27-9/16 x 7-15/32 x 27-9/16	35-7/16 x 7-15/32 x 27-9/16	
Net Unit Weight (lbs.)	35.1	45.4	45.4
Shipping Weight (lbs.)	43.4	55.2	55.2
Power Wiring Cable (No. x AWG) <sup>5</sup>	3 x 14		
Communications Wiring Cable (No. x AWG) <sup>5</sup>	2 x 18		
Heat Exchanger (Row x Column x Fin / inch) x Number	(2 x 11 x 14) x 1	(2 x 11 x 18) x 1	
Dehumidification Rate (pts/hr)	1.37	1.86	2.01
<i>Pipe Size</i>			
Liquid Line (in.)	1/4		
Vapor Line (in.)	3/8	1/2	
<i>Connection Size</i>			
Liquid Line (in.)	1/4		
Vapor Line (in.)	3/8	1/2	
Drain O.D. / I.D. (in.)	1-1/4, 1		

<sup>1</sup>Nominal capacity is rated 0 ft. above sea level with corresponding refrigerant piping length in accordance with standard length of each outdoor unit and a 0 ft. level difference between outdoor and indoor units. All capacities are net with a combination ratio between 95 – 105%.

Nominal cooling capacity rating obtained with air entering the indoor unit at 80°F dry bulb (DB) and 67°F wet bulb (WB) and outdoor ambient conditions of 95°F dry bulb (DB) and 75°F wet bulb (WB). Nominal heating capacity rating obtained with air entering the indoor unit at 70°F dry bulb (DB) and 60°F wet bulb (WB) and outdoor ambient conditions of 47°F dry bulb (DB) and 43°F wet bulb (WB).

<sup>2</sup>This unit comes with a dry helium charge.

<sup>3</sup>Acceptable operating voltage: 187V-253V.

<sup>4</sup>Sound pressure levels are tested in an anechoic chamber under ISO Standard 3745 and are the same in both cooling and heating mode. These values can increase due to ambient conditions during operation.

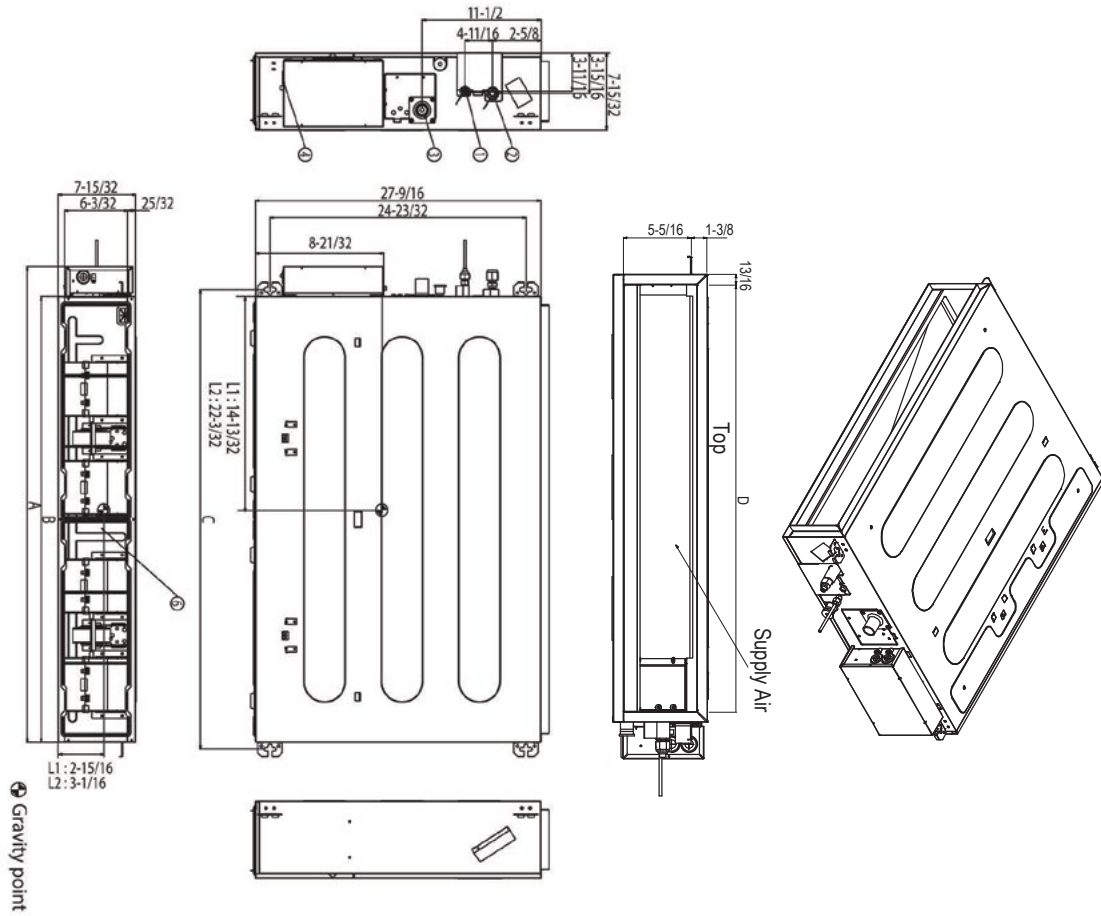
<sup>5</sup>The power wiring and the communication wiring from the outdoor unit to the indoor unit, or from the branch distribution unit to the indoor unit is field supplied and must be stranded, shielded or unshielded (if shielded, it must be grounded to the chassis of the outdoor unit only). All wiring must comply with applicable local and national codes.

# LOW STATIC DUCT INDOOR UNITS

## Dimensions

MULTI F  
MULTI F MAX

Figure 89: KNMKB091A, KNMKB121A, and KNMKB181A Dimensions.



Number	Name	Description
1	Liquid pipe connection	
2	Gas pipe connection	
3	Drain pipe connection	
4	Power supply connection	
5	Air discharge	
6	Air suction	

(unit: inch)

Model Number	A	B	C	D
KNMKB091A	30-15/32	27-9/16	28-27/32	25-31/32
KNMKB121A	38-11/32	35-7/16	36-23/32	33-27/32
KNMKB181A				

(unit: inch)

Table 35: Multi F Low Static Duct Indoor Units Cooling Capacity Table.

Model No. / Nominal Capacity of Indoor Unit (Btu/h)	Outdoor Air Temp. (°F DB)	Indoor Air Temp. °F DB / °F WB											
		68 / 57		73 / 61		77 / 64		80 / 67		86 / 72		90 / 75	
		TC	SHC	TC	SHC	TC	SHC	TC	SHC	TC	SHC	TC	SHC
KNMKB091A 9,000	14	8.82	7.55	9.37	7.98	9.92	7.72	10.31	7.89	11.01	7.95	11.56	8.10
	20	8.82	7.61	9.36	8.04	9.91	7.78	10.31	7.95	11.01	8.01	11.55	8.17
	25	8.81	7.67	9.36	8.10	9.90	7.84	10.30	8.01	11.00	8.08	11.54	8.23
	30	8.80	7.73	9.35	8.16	9.90	7.90	10.29	8.07	10.99	8.14	11.54	8.29
	35	8.80	7.79	9.34	8.22	9.89	7.96	10.28	8.13	10.98	8.20	11.53	8.36
	40	8.79	7.84	9.33	8.29	9.88	8.02	10.27	8.19	10.97	8.26	11.52	8.42
	45	8.78	7.90	9.33	8.35	9.87	8.08	10.27	8.25	10.96	8.32	11.51	8.48
	50	8.78	7.96	9.32	8.41	9.87	8.14	10.26	8.31	10.96	8.38	11.50	8.54
	55	8.77	8.02	9.31	8.47	9.86	8.20	10.25	8.38	10.95	8.45	11.49	8.61
	60	8.76	8.08	9.31	8.53	9.85	8.26	10.24	8.44	10.94	8.51	11.48	8.67
	65	8.76	8.14	9.30	8.59	9.84	8.32	10.24	8.50	10.93	8.57	11.47	8.73
	70	8.75	8.19	9.29	8.66	9.84	8.38	10.23	8.56	10.92	8.63	11.47	8.79
	75	8.54	8.06	9.08	8.52	9.62	8.26	10.01	8.44	10.71	8.53	11.25	8.69
	80	8.33	7.92	8.87	8.39	9.41	8.14	9.80	8.33	10.49	8.42	11.03	8.59
	85	8.12	7.78	8.66	8.25	9.20	8.02	9.59	8.20	10.28	8.30	10.82	8.48
	90	7.91	7.63	8.45	8.10	8.99	7.89	9.37	8.08	10.06	8.19	10.60	8.37
	95	7.68	7.55	8.22	8.03	8.75	7.83	<b>9.00</b>	<b>7.90</b>	9.83	8.14	10.36	8.34
	100	7.50	7.35	8.03	7.83	8.57	7.64	8.88	7.78	9.64	7.97	10.17	8.16
105	7.31	7.15	7.84	7.63	8.38	7.45	8.77	7.66	9.45	7.79	9.99	7.99	
110	7.12	6.90	7.66	7.38	8.19	7.22	8.58	7.43	9.26	7.57	9.80	7.77	
115	6.94	6.69	7.47	7.17	8.01	7.03	8.39	7.24	9.08	7.39	9.61	7.60	
118	6.82	6.65	7.36	7.13	7.89	7.00	8.28	7.21	8.96	7.37	9.50	7.58	
122	6.79	6.63	7.32	7.11	7.86	6.98	8.24	7.19	8.93	7.36	9.46	7.57	
KNMKB121A 12,000	14	11.76	9.94	12.49	10.50	13.22	10.17	13.75	10.38	14.69	10.47	15.42	10.67
	20	11.75	10.02	12.48	10.58	13.21	10.25	13.74	10.46	14.67	10.55	15.40	10.75
	25	11.75	10.09	12.48	10.66	13.20	10.33	13.73	10.54	14.66	10.63	15.39	10.83
	30	11.74	10.17	12.47	10.75	13.19	10.40	13.72	10.62	14.65	10.71	15.38	10.92
	35	11.73	10.25	12.46	10.83	13.18	10.48	13.71	10.70	14.64	10.79	15.37	11.00
	40	11.72	10.33	12.45	10.91	13.17	10.56	13.70	10.79	14.63	10.88	15.36	11.08
	45	11.71	10.40	12.44	10.99	13.16	10.64	13.69	10.87	14.62	10.96	15.35	11.16
	50	11.70	10.48	12.43	11.07	13.15	10.72	13.68	10.95	14.61	11.04	15.33	11.25
	55	11.69	10.56	12.42	11.15	13.14	10.80	13.67	11.03	14.60	11.12	15.32	11.33
	60	11.68	10.63	12.41	11.23	13.13	10.88	13.66	11.11	14.59	11.20	15.31	11.41
	65	11.67	10.71	12.40	11.31	13.12	10.96	13.65	11.19	14.57	11.28	15.30	11.49
	70	11.66	10.79	12.39	11.40	13.11	11.03	13.64	11.27	14.56	11.36	15.29	11.58
	75	11.38	10.61	12.11	11.22	12.83	10.88	13.35	11.12	14.27	11.22	15.00	11.45
	80	11.10	10.43	11.82	11.05	12.55	10.72	13.07	10.96	13.99	11.08	14.71	11.31
	85	10.83	10.24	11.54	10.86	12.26	10.55	12.78	10.80	13.70	10.93	14.42	11.17
	90	10.55	10.04	11.26	10.67	11.98	10.38	12.50	10.63	13.42	10.78	14.13	11.02
	95	10.25	9.94	10.96	10.57	11.67	10.30	<b>12.00</b>	<b>10.40</b>	13.10	10.72	13.81	10.97
	100	10.00	9.67	10.71	10.31	11.42	10.06	11.84	10.24	12.85	10.49	13.56	10.75
105	9.75	9.41	10.46	10.04	11.17	9.81	11.69	10.08	12.60	10.26	13.31	10.52	
110	9.50	9.09	10.21	9.72	10.92	9.51	11.44	9.78	12.35	9.97	13.07	10.24	
115	9.25	8.81	9.96	9.44	10.67	9.26	11.19	9.53	12.10	9.73	12.82	10.00	
118	9.10	8.75	9.81	9.39	10.52	9.21	11.04	9.49	11.95	9.70	12.67	9.98	
122	9.05	8.73	9.76	9.37	10.48	9.19	10.99	9.47	11.90	9.69	12.62	9.97	

TC = Total Capacity (kBtu/h).

SHC: Sensible Heat Capacity (kBtu/h).

Nominal capacity as rated 0 ft. above sea level and a 0 ft. level difference between outdoor and indoor units. Corresponding refrigerant piping length is accordance with standard length of each outdoor unit.

Nominal cooling capacity rating obtained with air entering the indoor unit at 80°F dry bulb (DB) and 67°F wet bulb (WB), and outdoor ambient conditions of 95°F dry bulb (DB) and 75°F wet bulb (WB).

The shaded table columns and rows indicate reference data. When operating at this temperature, these values can be different if the system is not running consistently.

Low Static Duct

# LOW STATIC DUCT INDOOR UNITS

## Cooling Capacity Table

MULTI F  
MULTI F MAX

Table 36: Multi F Low Static Duct Indoor Units Cooling Capacity Table (continued).

Model No. / Nominal Capacity of Indoor Unit (Btu/h)	Outdoor Air Temp. (°F DB)	Indoor Air Temp. °F DB / °F WB											
		68 / 57		73 / 61		77 / 64		80 / 67		86 / 72		90 / 75	
		TC	SHC	TC	SHC	TC	SHC	TC	SHC	TC	SHC	TC	SHC
KNMKB181A 18,000	14	17.65	13.09	18.74	13.83	19.84	13.39	20.63	13.67	22.03	13.79	23.12	14.05
	20	17.63	13.20	18.73	13.94	19.82	13.50	20.61	13.78	22.01	13.90	23.11	14.16
	25	17.62	13.30	18.71	14.05	19.81	13.60	20.60	13.89	22.00	14.01	23.09	14.27
	30	17.60	13.40	18.70	14.16	19.79	13.71	20.58	13.99	21.98	14.11	23.07	14.38
	35	17.59	13.50	18.68	14.26	19.78	13.81	20.57	14.10	21.96	14.22	23.05	14.49
	40	17.58	13.60	18.67	14.37	19.76	13.91	20.55	14.21	21.94	14.33	23.04	14.60
	45	17.56	13.71	18.66	14.48	19.75	14.02	20.53	14.31	21.93	14.43	23.02	14.71
	50	17.55	13.81	18.64	14.58	19.73	14.12	20.52	14.42	21.91	14.54	23.00	14.82
	55	17.54	13.91	18.63	14.69	19.72	14.23	20.50	14.52	21.89	14.65	22.98	14.92
	60	17.52	14.01	18.61	14.80	19.70	14.33	20.49	14.63	21.88	14.75	22.97	15.03
	65	17.51	14.11	18.60	14.90	19.69	14.43	20.47	14.74	21.86	14.86	22.95	15.14
	70	17.50	14.21	18.58	15.01	19.67	14.53	20.46	14.84	21.84	14.97	22.93	15.25
	75	17.08	13.98	18.16	14.78	19.24	14.33	20.03	14.64	21.41	14.78	22.50	15.08
	80	16.66	13.74	17.74	14.55	18.82	14.12	19.60	14.44	20.98	14.60	22.06	14.90
	85	16.24	13.49	17.32	14.30	18.40	13.90	19.17	14.23	20.55	14.40	21.63	14.71
	90	15.82	13.23	16.90	14.06	17.97	13.68	18.75	14.01	20.12	14.20	21.20	14.52
	95	15.37	13.09	16.44	13.93	17.51	13.57	<b>18.00</b>	<b>13.70</b>	19.65	14.12	20.72	14.46
	100	14.99	12.74	16.06	13.58	17.13	13.25	17.77	13.49	19.28	13.82	20.35	14.16
105	14.62	12.39	15.69	13.23	16.76	12.93	17.53	13.28	18.90	13.52	19.97	13.86	
110	14.24	11.97	15.32	12.80	16.39	12.53	17.16	12.88	18.53	13.13	19.60	13.48	
115	13.87	11.61	14.94	12.44	16.01	12.19	16.79	12.55	18.15	12.82	19.22	13.18	
118	13.65	11.53	14.72	12.36	15.79	12.13	16.56	12.50	17.93	12.77	19.00	13.14	
122	13.57	11.50	14.64	12.34	15.71	12.11	16.49	12.48	17.85	12.76	18.92	13.13	

TC = Total Capacity (kBtu/h).

SHC: Sensible Heat Capacity (kBtu/h).

Nominal capacity as rated 0 ft. above sea level and a 0 ft. level difference between outdoor and indoor units. Corresponding refrigerant piping length is accordance with standard length of each outdoor unit.

Nominal cooling capacity rating obtained with air entering the indoor unit at 80°F dry bulb (DB) and 67°F wet bulb (WB), and outdoor ambient conditions of 95°F dry bulb (DB) and 75°F wet bulb (WB).

The shaded table columns and rows indicate reference data. When operating at this temperature, these values can be different if the system is not running consistently.

Multi F and Multi F MAX Indoor Unit Engineering Manual

Table 37: Multi F Low Static Duct Indoor Units Heating Capacity Table.

Model No. / Nominal Capacity of Indoor Unit (Btu/h)	Outdoor Air Temp.		Indoor Air Temp. °F DB					
	°F DB	°F WB	61	64	68	70	72	75
			TC	TC	TC	TC	TC	TC
KNMKB091A 9,000	0	-0.4	5.35	5.28	5.23	5.20	5.12	4.90
	5	4.5	6.03	5.95	5.90	5.88	5.80	5.58
	10	9	6.71	6.63	6.58	6.56	6.48	6.26
	17	15	7.61	7.54	7.49	<b>7.46</b>	7.39	7.14
	20	19	7.95	7.88	7.83	7.80	7.72	7.46
	25	23	8.52	8.44	8.39	8.37	8.29	7.99
	30	28	9.01	8.93	8.88	8.86	8.78	8.52
	35	32	9.50	9.42	9.37	9.34	9.27	9.04
	40	36	9.94	9.86	9.81	9.78	9.71	9.48
	45	41	10.37	10.30	10.25	10.22	10.15	9.92
	47	43	10.55	10.48	10.43	<b>10.40</b>	10.32	10.10
	50	46	10.72	10.64	10.59	10.57	10.49	10.24
	55	51	11.00	10.93	10.88	10.85	10.78	10.48
	60	56	11.00	10.93	10.88	10.85	10.78	10.52
	63	59	11.00	10.93	10.88	10.85	10.78	10.55
68	64	11.00	10.93	10.88	10.85	10.78	10.60	
KNMKB121A 12,000	0	-0.4	7.10	7.00	6.93	6.90	6.80	6.50
	5	4.5	8.00	7.90	7.83	7.80	7.70	7.40
	10	9	8.90	8.80	8.73	8.70	8.60	8.30
	17	15	10.10	10.00	9.93	<b>9.90</b>	9.80	9.48
	20	19	10.55	10.45	10.38	10.35	10.25	9.90
	25	23	11.30	11.20	11.13	11.10	11.00	10.60
	30	28	11.95	11.85	11.78	11.75	11.65	11.30
	35	32	12.60	12.50	12.43	12.40	12.30	12.00
	40	36	13.18	13.08	13.02	12.98	12.88	12.58
	45	41	13.77	13.67	13.60	13.57	13.47	13.17
	47	43	14.00	13.90	13.83	<b>13.80</b>	13.70	13.40
	50	46	14.23	14.13	14.06	14.03	13.93	13.59
	55	51	14.60	14.50	14.43	14.40	14.30	13.90
	60	56	14.60	14.50	14.43	14.40	14.30	13.96
	63	59	14.60	14.50	14.43	14.40	14.30	14.00
68	64	14.60	14.50	14.43	14.40	14.30	14.06	
KNMKB181A 18,000	0	-0.4	10.70	10.55	10.45	10.40	10.25	9.80
	5	4.5	12.06	11.91	11.81	11.76	11.61	11.15
	10	9	13.41	13.26	13.16	13.11	12.96	12.51
	17	15	15.22	15.07	14.97	<b>14.92</b>	14.77	14.29
	20	19	15.90	15.75	15.65	15.60	15.45	14.92
	25	23	17.03	16.88	16.78	16.73	16.58	15.98
	30	28	18.01	17.86	17.76	17.71	17.56	17.03
	35	32	18.99	18.84	18.74	18.69	18.54	18.09
	40	36	19.87	19.72	19.62	19.57	19.42	18.97
	45	41	20.75	20.60	20.50	20.45	20.30	19.85
	47	43	21.10	20.95	20.85	<b>20.80</b>	20.65	20.20
	50	46	21.44	21.29	21.19	21.14	20.99	20.48
	55	51	22.01	21.86	21.75	21.70	21.55	20.95
	60	56	22.01	21.86	21.75	21.70	21.55	21.04
	63	59	22.01	21.86	21.75	21.70	21.55	21.10
68	64	22.01	21.86	21.75	21.70	21.55	21.20	

TC = Total Capacity (kBtu/h).

Nominal capacity as rated 0 ft. above sea level and a 0 ft. level difference between outdoor and indoor units. Corresponding refrigerant piping length is accordance with standard length of each outdoor unit. Nominal heating capacity rating obtained with air entering the indoor unit at 70°F dry bulb (DB) and 60°F wet bulb (WB), and outdoor ambient conditions of 47°F dry bulb (DB) and 43°F wet bulb (WB).

Low Static Duct

# LOW STATIC DUCT INDOOR UNITS

External Static Pressure

MULTI F  
MULTI F MAX

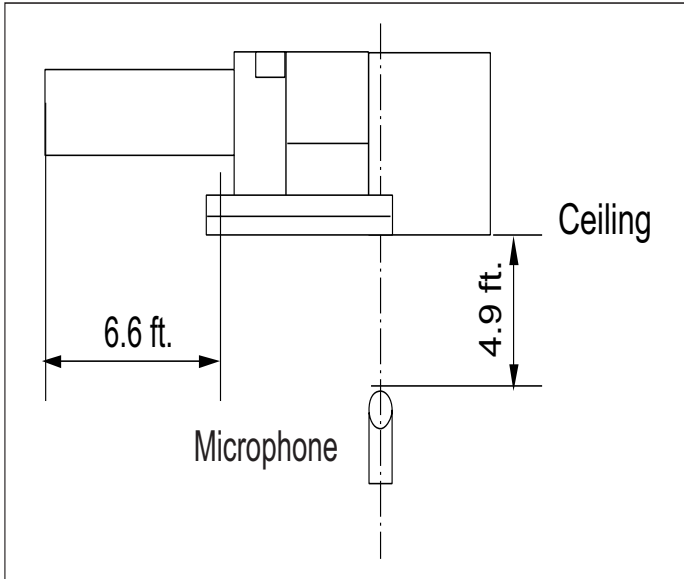
Table 38: Multi F Low Static Duct External Static Pressure Setting Values Table.

Static Pressure (in. wg)		0.0	0.04	0.08	0.12	0.16	0.20	
Model No. / Nominal Capacity of Indoor Unit (Btu/h)	Airflow Rate / CFM	Setting Value						
		KNMKB091A 9,000	High	318	98	103	108	116
Mid	247		82	88	94	102	110	118
Low	194		69	76	83	91	99	109
KNMKB121A 12,000	High	353	95	99	104	109	116	124
	Mid	300	86	91	96	101	108	116
	Low	247	78	82	87	93	100	108
KNMKB181A 18,000	High	530	123	125	129	134	141	145
	Mid	441	109	112	117	123	129	136
	Low	353	95	99	104	109	116	124

**NOTICE**

- To get the desired air flow and external static pressure combination, use the setting value from the table. Using a setting value other than that listed in the table will not provide the desired combination.
- Table data is based at 230V. Air flow rate varies according to voltage fluctuation.

Figure 90: Sound Pressure Level Measurement Location.

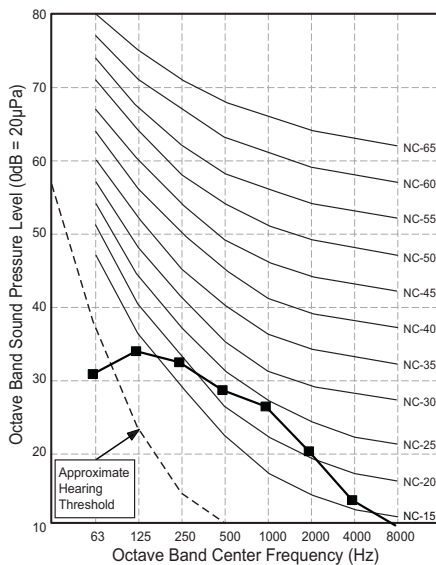


- Measurements taken with no attenuation and units operating at full load normal operating condition.
- Sound level will vary depending on a range of factors such as construction (acoustic absorption coefficient) of particular area in which the equipment is installed.
- Sound power levels are measured in dB(A).
- Tested in anechoic chamber per ISO Standard 3745.

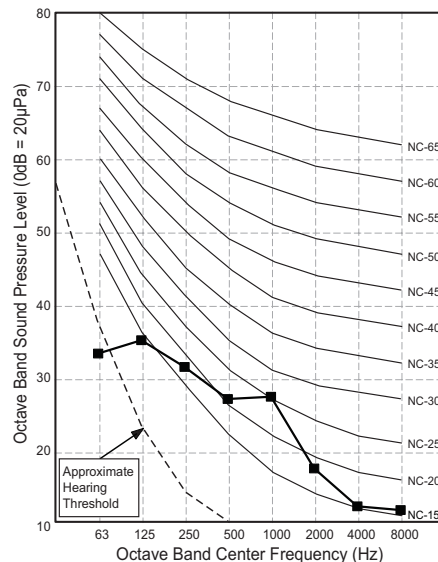
Table 39: Sound Pressure Levels (dB[A]).

Model No.	Sound Pressure Levels (dB[A]) (Cooling and Heating)		
	High Fan Speed	Medium Fan Speed	Low Fan Speed
KNMKB091A	30	26	23
KNMKB121A	31	28	27
KNMKB181A	36	34	31

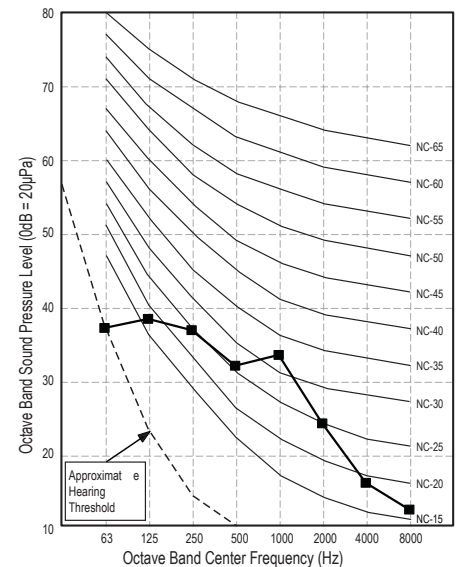
Figure 91: Sound Pressure Level Diagrams.  
KNMKB091A



KNMKB121A



KNMKB181A



# LOW STATIC DUCT INDOOR UNITS

## Refrigerant Flow Diagram

MULTI F  
MULTI F MAX

Figure 92: KNMKB091A Refrigerant Flow Diagram.

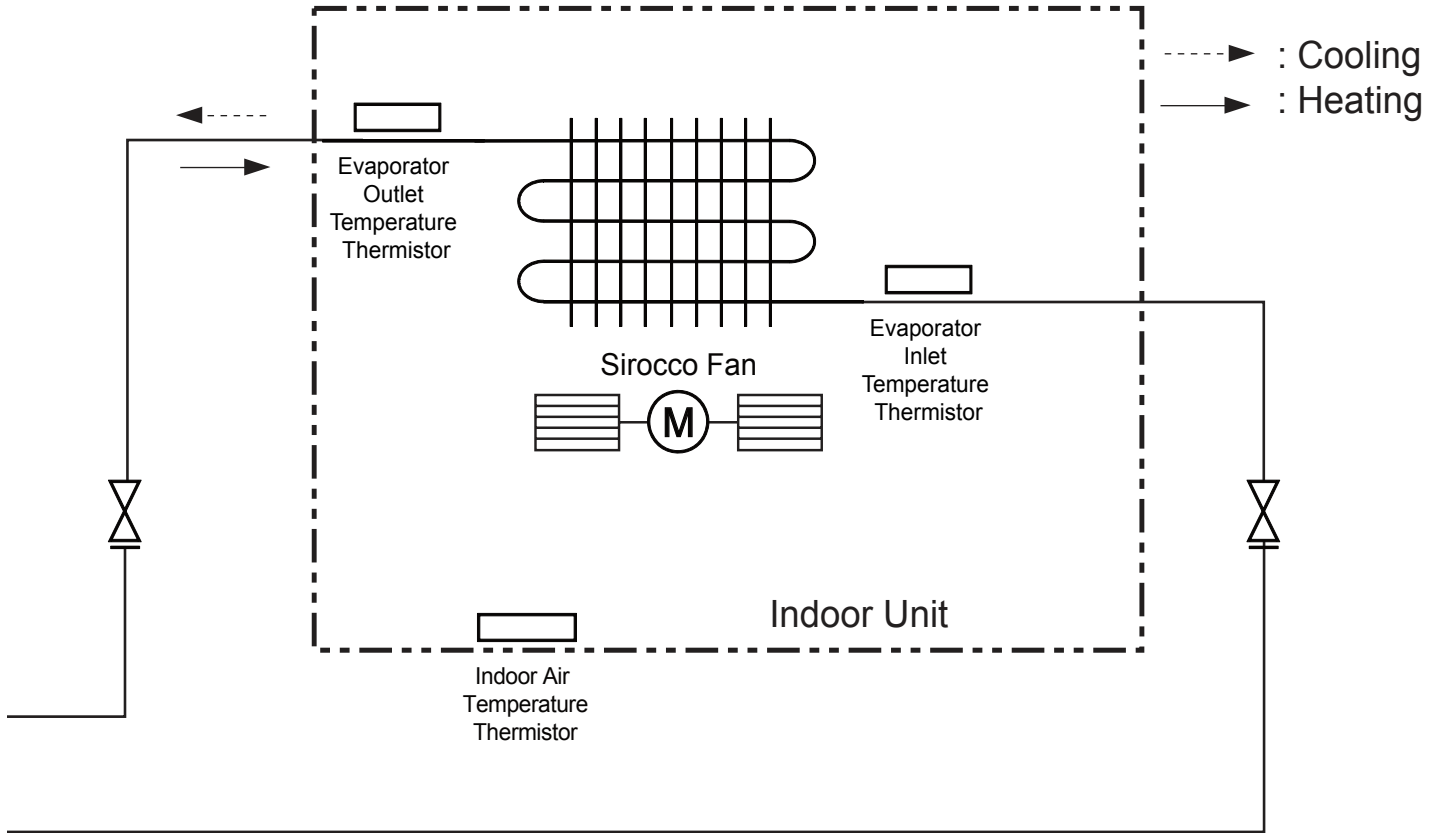


Table 40: Multi F Low Static Duct KNMKB091A Indoor Unit Refrigerant Pipe Sizes.

Model No.	Vapor (inch)	Liquid (inch)
KNMKB091A	Ø3/8	Ø1/4

Table 41: Multi F Low Static Duct KNMKB091A Refrigerant Pipe Connections.

Model No.	Vapor (inch)	Liquid (inch)
KNMKB091A	Ø3/8	Ø1/4

Table 42: Multi F Low Static Duct KNMKB091A Indoor Unit Thermistor Details.

Description (Based on Cooling Mode)	PCB Connector
Indoor Air Temperature Thermistor	CN-ROOM
Evaporator Inlet Temperature Thermistor	CN-PIPE/IN
Evaporator Outlet Temperature Thermistor	CN-PIPE/OUT

Figure 93: KNMKB121A and KNMKB181A Refrigerant Flow Diagram.

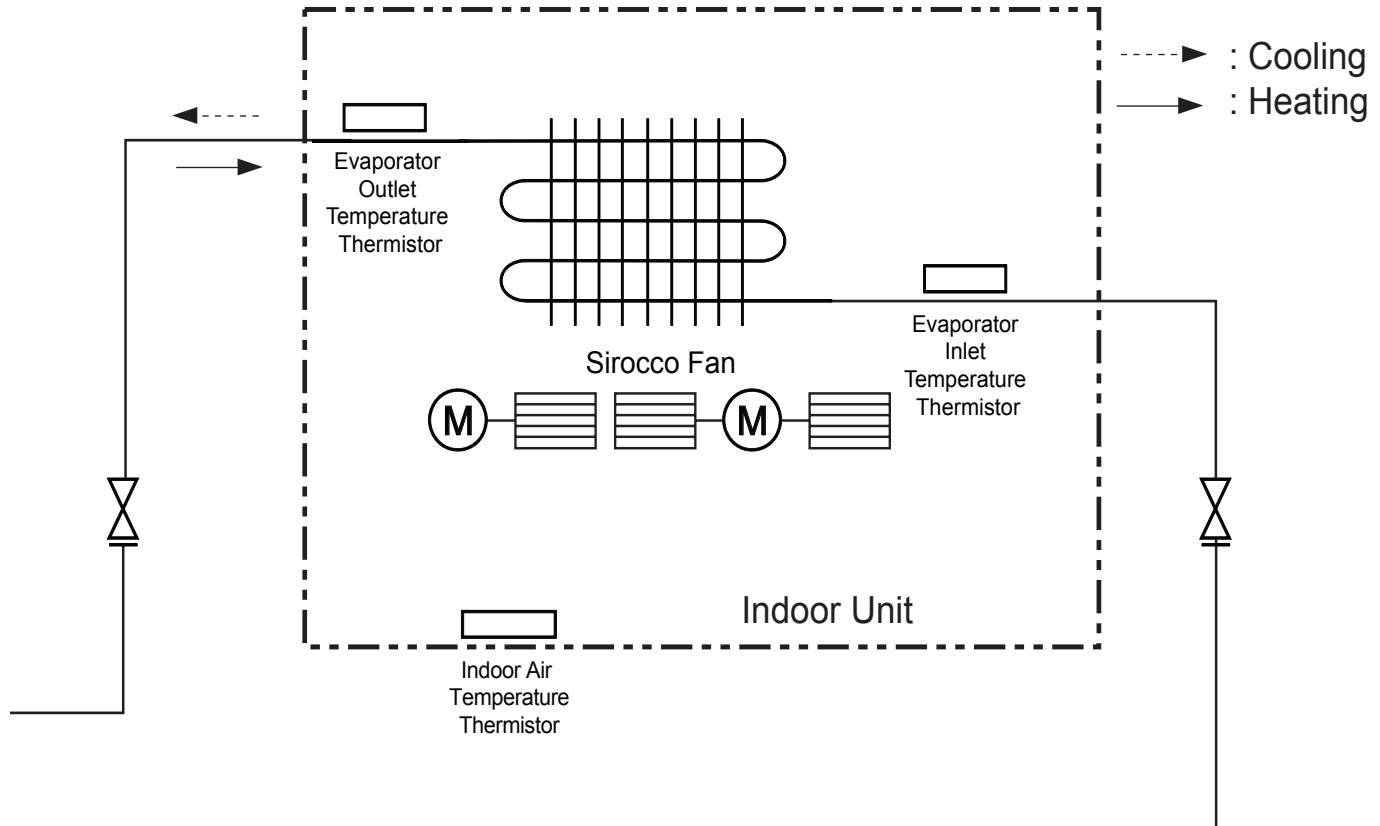


Table 43: Multi F Low Static Duct KNMKB121A and KNMKB181A Indoor Unit Refrigerant Pipe Sizes.

Model No.	Vapor (inch)	Liquid (inch)
KNMKB121A	Ø3/8	Ø1/4
KNMKB181A	Ø1/2	

Table 44: Multi F Low Static Duct KNMKB121A and KNMKB181A Indoor Unit Refrigerant Pipe Connections.

Model No.	Vapor (inch)	Liquid (inch)
KNMKB121A	Ø3/8	Ø1/4
KNMKB181A	Ø1/2	

Table 45: Multi F Low Static Duct KNMKB121A and KNMKB181A Indoor Unit Thermistor Details.

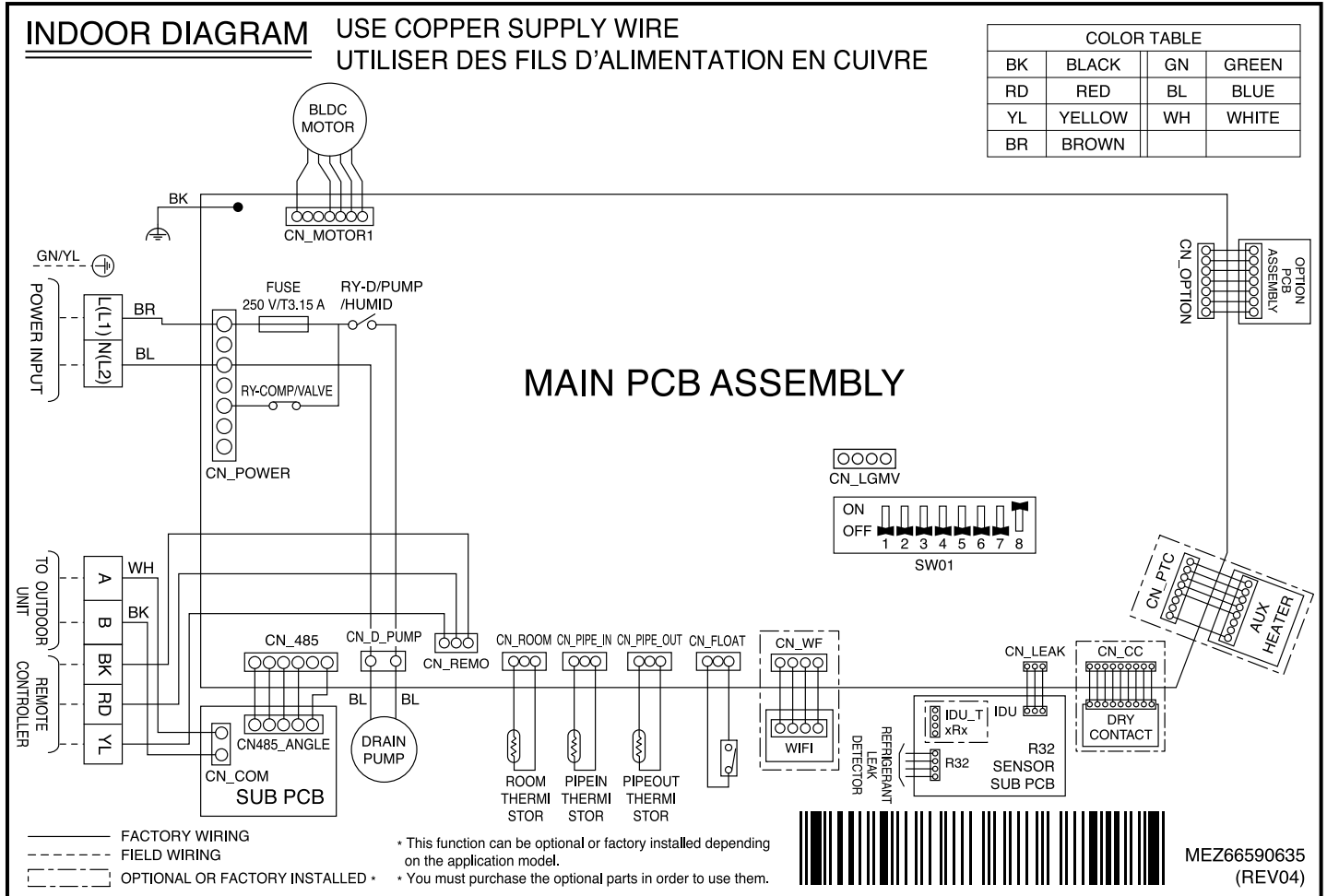
Description (Based on Cooling Mode)	PCB Connector
Indoor Air Temperature Thermistor	CN-ROOM
Evaporator Inlet Temperature Thermistor	CN-PIPE/IN
Evaporator Outlet Temperature Thermistor	CN-PIPE/OUT

# LOW STATIC DUCT INDOOR UNITS

## Wiring Diagram

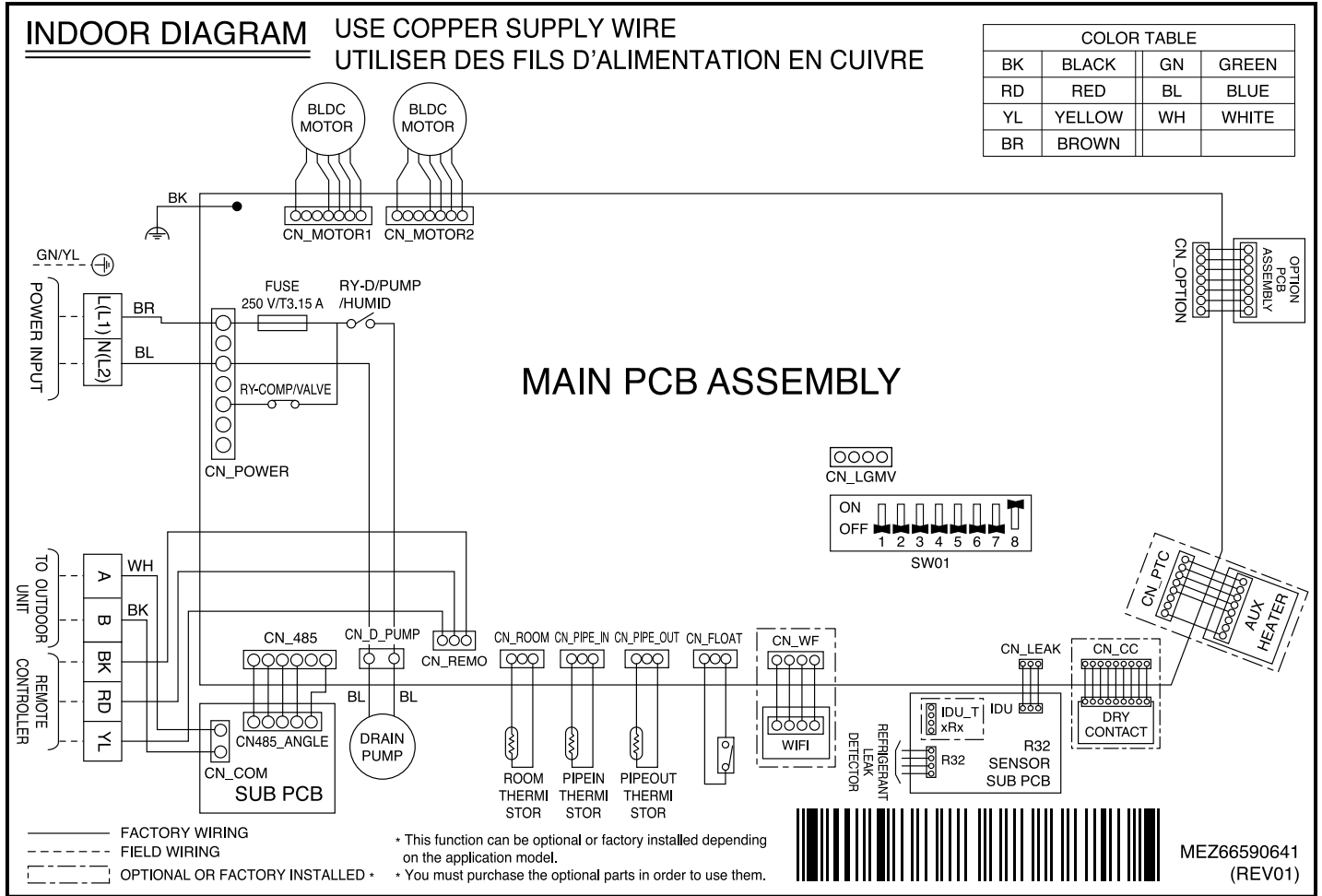
MULTI F  
MULTI F MAX

Figure 94: Multi F Low Static Duct KNMKB091A Indoor Units Wiring Diagram.



Multi F and Multi F MAX Indoor Unit Engineering Manual

Figure 95: Multi F Low Static Duct KNMKB121A and KNMKB181A Indoor Units Wiring Diagram.






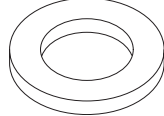
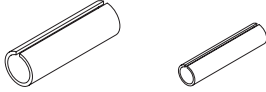
# LOW STATIC DUCT INDOOR UNITS

Factory Supplied Parts and Materials

MULTI F  
MULTI F MAX

## Factory Supplied Parts

Table 46: Parts Table.

Part	Quantity	Image	Part	Quantity	Image
Drain Hose	One (1)		Zip Ties	Four (4)	
Metal Clamp	Two (2)		Washers for Hanging Brackets	Eight (8)	
Insulation for Fittings	One (1) Set	 For Vapor Piping    For Liquid Piping			

## Factory Supplied Materials

- Owner's Manual
- Installation Manual

## Required Tools

- Level
- Screwdriver
- Electric drill
- Hole core drill
- Flaring tool set
- Torque wrenches
- Hexagonal wrench
- Gas-leak detector
- Thermometer

### **⚠ WARNING**

Installation work must be performed by trained personnel and in accordance with national wiring standards and all local or other applicable codes. Improper installation can result in fire, electric shock, physical injury, or death.

### **NOTICE**

Read all instructions before installing this product. Become familiar with the unit's components and connections, and the order of installation. Incorrect installation can degrade or prevent proper operation.

### Selecting the Best Location

#### Do's

- Place the unit where air circulation will not be blocked.
- Place the unit where drainage can be obtained easily.
- Place the unit where noise prevention is taken into consideration.
- Ensure there is sufficient strength to bear the load of the indoor unit.
- Ensure there is sufficient maintenance space.
- Locate the indoor unit in a location that is level, and where it can be easily connected to the outdoor unit / branch distribution unit.

#### Don'ts

- Do not install the unit near a heat or steam source, or where considerable amounts of oil, iron powder, or flour are used.
- Do not install the unit where sulfuric acid and flammable or corrosive gases are generated, vented into, or stored.
- Do not install the unit near high-frequency generators.
- Do not install the unit near a doorway.

The unit will be damaged, will malfunction, and / or will not operate as designed if installed in any of the conditions listed.

### Installing in an Area Exposed to Unconditioned Air

In some installation applications, areas (floors, walls) in some rooms will be exposed to unconditioned air (room will be above or next to an unheated garage or storeroom). To countermeasure:

- Verify that carpet is or will be installed (carpet will increase the temperature by three degrees).
- Add insulation between the floor joists.
- Install radiant heat or another type of heating system to the floor.

### Installing in an Area with High Humidity Levels

If the environment is prone to humidity levels of 80% or more (near the ocean, lakes, etc.) or where steam could collect in the plenum:

- Install additional insulation to the indoor unit (glass wool insulation >13/32 inches thick).
- Install additional insulation to the refrigerant piping (insulation >13/16 inches thick).
- Seal all gaps between the indoor unit and the ceiling tiles (make the area air tight) so that humidity does not transfer from the plenum to the conditioned space. Also, add a ceiling grille for ventilation.

### NOTICE

- Indoor units (IDUs) must not be placed in an environment where the IDUs will be exposed to harmful volatile organic compounds (VOCs) or in environments where there is improper air make up or supply or inadequate ventilation. If there are concerns about VOCs in the environment where the IDUs are installed, proper air make up or supply and/or adequate ventilation must be provided. Additionally, in buildings where IDUs will be exposed to VOCs, consider a third party factory-applied epoxy coating to the fan coils for each IDU where the entire coil is dipped, not sprayed.
- If the unit is installed near a body of water, the installation parts are at risk of corroding. Appropriate anti-corrosion methods must be taken for the unit and all installation parts.

Figure 96: General Installation Guidelines.

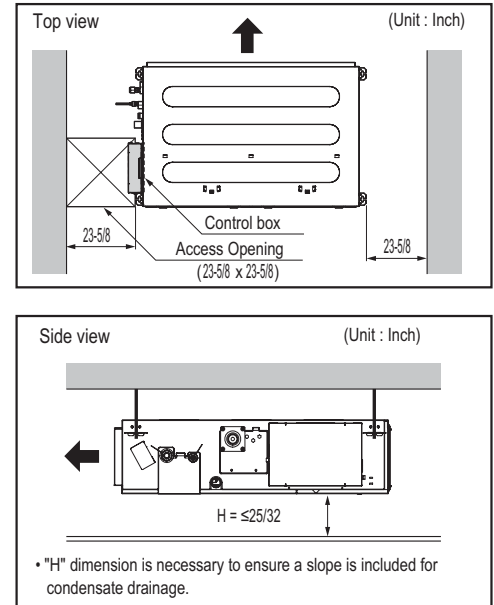


Figure 97: Service / Access Panel Dimensions.

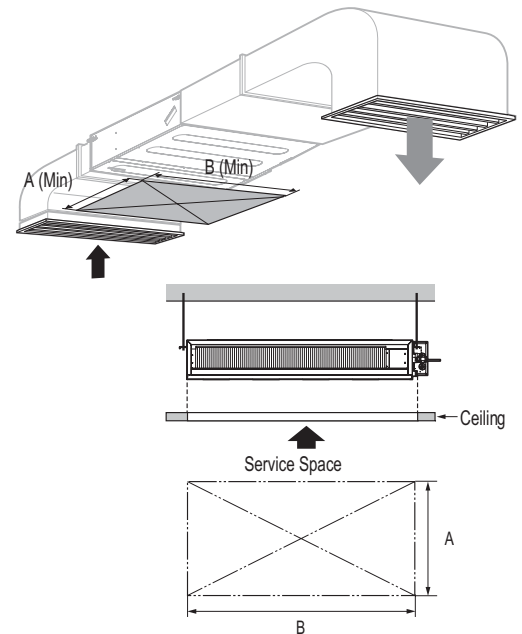


Table 47: General Access Panel Dimensions.

Model / Capacity (Btu/h)	Dimensions (in.)	
	A	B
KNMKB091A / 9,000	31-1/2	31-1/2
KNMKB121A / 12,000		39-3/8
KNMKB181A / 18,000		

# LOW STATIC DUCT INDOOR UNITS

## Installation and Best Layout Practices

MULTI F  
MULTI F MAX

Low Static Duct Indoor Units can be installed in two ways:

Figure 98: Air inlet from the back of the indoor unit.

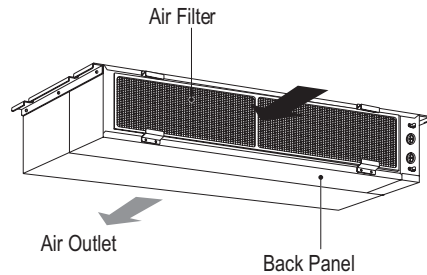


Figure 99: Air inlet from the bottom of the indoor unit.

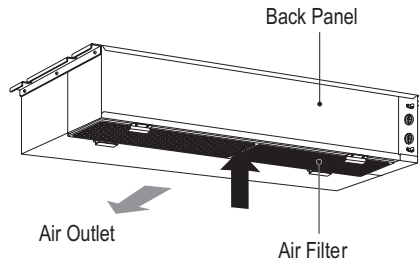


Table 49: Indoor Unit Bolt Locations.

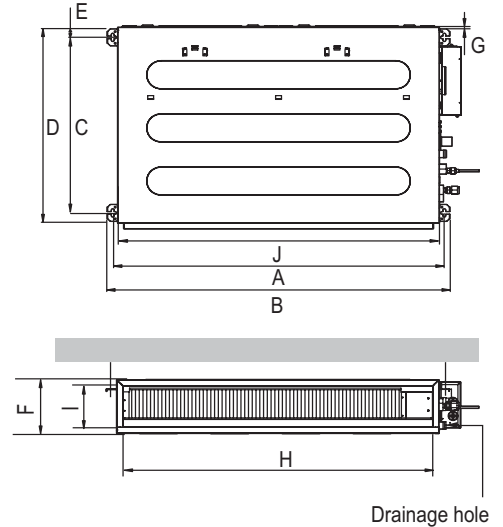


Table 48: Indoor Unit Bolt Location Dimensions.

Model / Capacity (Btu/h)	Dimensions (in.)									
	A	B	C	D	E	F	G	H	I	J
KNMKB091A / 9,000	28-27/32	30-13/32	24-23/32	27-9/16	1-13/32	7-15/32	25/32	25-31/32	6-3/32	27-9/16
KNMKB121A / 12,000	36-23/32	38-9/32						33-27/32		35-7/16
KNMKB181A / 18,000										

## Preparing the Installation Area and Hanging the Indoor Unit Frame

1. Select and mark the area for the suspension or console bolts (use embedded inserts or anchor bolts in new buildings, and hole-in-anchors in older buildings).
2. Drill the holes.
3. Add the set-anchor and the plate washer to the bolts (bolts must be at least 13/32 inches in diameter), and then insert the bolts into the installation area.
4. Add the plate washer, spring washer, and nut to secure the bolts into the installation area.
5. Position the indoor unit installation plates onto the bolts. Secure using nuts, plate washers, and spring washers. Adjust for level as necessary.

Figure 100: Preparing the Installation Area.

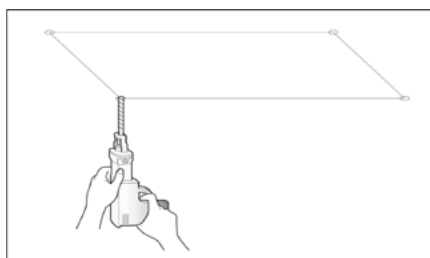


Figure 101: Console Bolt Options.

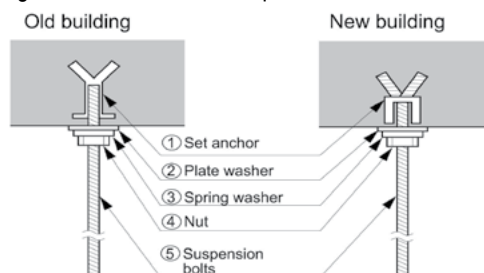
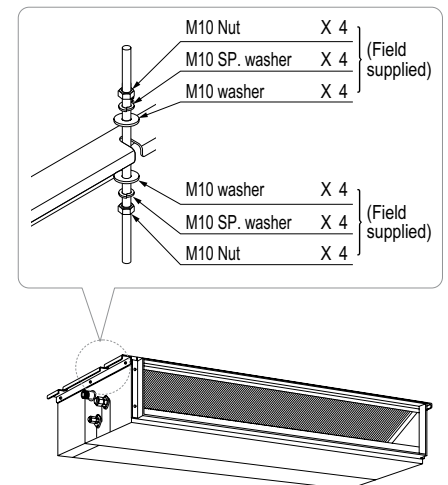


Figure 102: Hanging the Indoor Unit.



### NOTICE

Install a canvas duct to the air outlet and air inlet so that vibration from the indoor unit does not carry to the duct or ceiling. Also, add insulation to the interior of the duct, and apply anti-vibration to the suspension bolts.

### WARNING

- Unit must be installed correctly.
- Tighten the nuts and bolts to prevent the unit from falling.

### Installing the Drain System

- Drain piping must have downward gradient of at least 1/50 to 1/100; to prevent reverse flow, slope must not be straight up and down.
- Do not damage the drain port on the indoor unit when connecting the field-supplied drain piping.
- Drain piping specifications:
  - Indoor Unit Drain Connection: 1-1/4 inch outside diameter.
  - Field-Supplied Drain Piping: Polyvinyl chloride piping with 1-inch inside diameter and pipe fittings.

Ducted (low static) indoor units have two options for condensate drainage: Using the factory-installed drain pump, or using a gravity drain.

#### Using the Drain Pump

- Maximum drain lift is 27-9/16 inches, therefore, the drain piping must be placed below the maximum lift height.
- Field-installed drain piping must have downward gradient of at least 1/50 to 1/100; to prevent reverse flow, slope must not be straight up and down.

#### Using the Gravity Drain

Field-drain piping must have downward gradient of at least 1/50 to 1/100; to prevent reverse flow, slope must not be straight up and down.

### Checking the Drain Pump

The unit uses a drain pump to remove condensate. The pump must be tested before the system operates.

- Connect the flexible drain hose to the field-installed drain piping; leave it as is until the test is complete.
- Pour water into the flexible drain hose and check for leaks.
- After power wiring installation is complete, operate the drain pump to see if it sounds and functions properly.
- After the test is complete, connect the flexible drain hose to the indoor unit drain port.

### Checking the Drainage System

1. Remove the air filter.
2. Check the drainage.
  - Spray water on the evaporator.
  - Verify that water flows through the indoor unit drain hose without leaking.

Figure 103: Drain Connection.

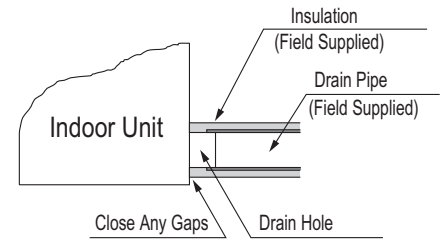
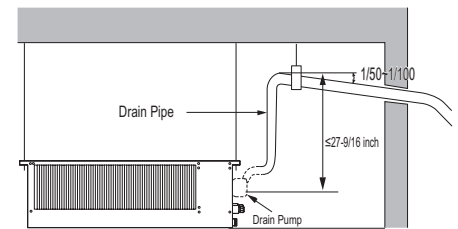


Figure 104: Indoor Unit Using Drain Pump.



*Pump location will be different on the indoor unit.*

Figure 105: Indoor Unit Using Gravity Drain.

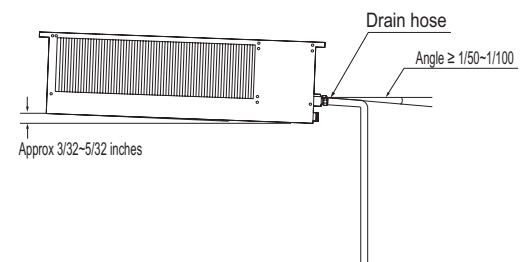
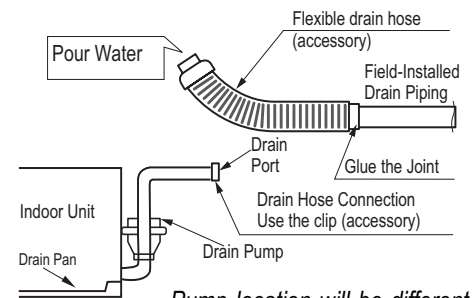
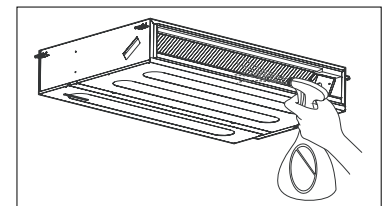
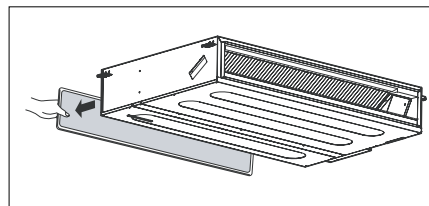


Figure 106: Checking the Drain Pump.



*Pump location will be different on the indoor unit.*

Figure 107: Checking the Drainage System.



# LOW STATIC DUCT INDOOR UNITS

## Installation and Best Layout Practices

MULTI F  
MULTI F MAX

### Insulating the Refrigerant and Drain Piping

#### **⚠ WARNING**

Ensure all piping is insulated. Exposed piping can cause burns if touched.

#### **Refrigerant Piping Insulation**

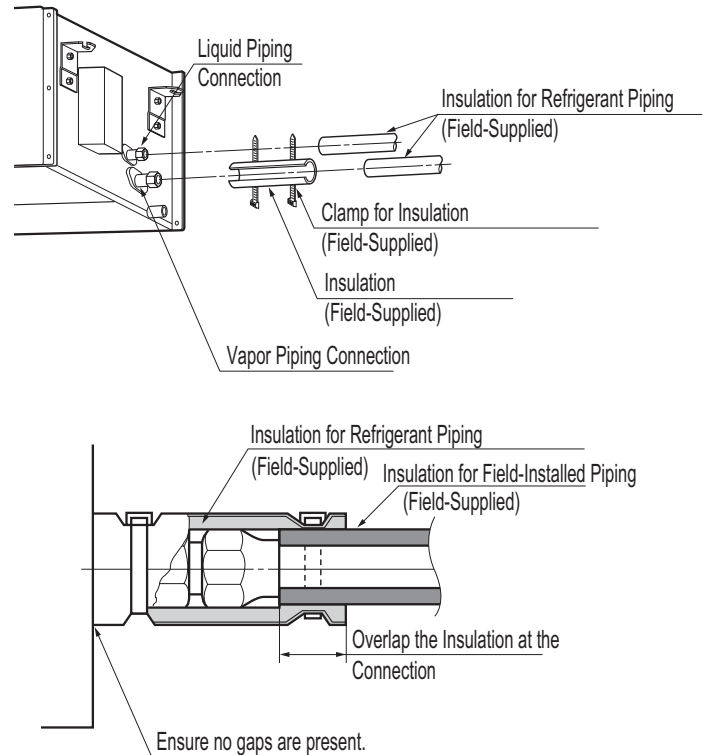
Field-installed vapor and liquid refrigerant piping lines must be properly and completely covered in insulation (up to the indoor unit piping connections). Any exposed piping will generate condensate or will cause burns if touched. Insulation for this field-installed refrigerant piping must have a minimum heat resistance of 248°F.

Low Static Duct indoor units have been tested under and meet the requirements of the "KS Conditions." If the indoor unit is installed and is operated at an extended period in a highly humid environment (dew point temperature >73°F), however, condensate will form. To prevent this phenomenon, install adiabatic glass wool insulation with a thickness of 13/32 to 13/16 inches thick. Also, install glass wool insulation on all indoor unit that are located in the ceiling plenum.

#### **Drain Piping Insulation**

Drain piping must have insulation a minimum of 7/32 inches thick.

Figure 108: Insulating the Piping.



### Power Wiring / Communications Cable Guidelines

- Follow manufacturer's circuit diagrams in the technical manuals.
- Confirm power source specifications.
- Confirm that the electrical capacity is sufficient.
- Starting current must be maintained  $\pm 10$  percent of the rated current marked on the outdoor unit name plate.
- Confirm cable thickness specifications.
- It is required that a circuit breaker is installed, especially if conditions could become wet or moist.
- Include a disconnect in the power wiring system, add an air gap contact separation of at least 1/8 inch in each active (phase) conductor.



### **⚠ WARNING**

- Loose wiring will cause unit to malfunction, overheat, and catch fire, resulting in severe injury or death.

### **NOTICE**

- Terminal screws will become loose during transport. Properly tighten the terminal connections during installation.
- A voltage drop will cause the following problems:
- Magnetic switch vibration, fuse breaks, or disturbance to the normal function of an overload protection device.
  - Compressor will not receive the proper starting current.

### Connecting the Power Wiring and Communications Cable

1. Insert the power wiring / communications cable from the outdoor unit or branch distribution unit (Multi F MAX systems only) through the side of the indoor unit. Pass the wiring through the designated access holes to prevent damage. To prevent electromagnetic interference and product malfunction, leave a space between the power wiring and communications cable outside of the indoor unit.
2. Connect each wire to its appropriate terminal on the indoor unit control board. Verify that the color and terminal numbers from the outdoor unit or branch distribution unit (Multi F MAX systems only) wiring match the color and terminal numbers on the indoor unit.
3. Secure the power wiring / communications cable with the cable restraint.
4. Screw the steel clamp to the inside of the control panel.
  - Place the wiring / cables in the clamp and tighten the plastic clamp to an open surface of the control panel.
  - When clamping,  do not apply force to the wiring connections.
  - Neatly arrange the wiring,  do not catch the wiring in the electric box cover, and ensure the cover firmly closes.
5. Fill in any gaps around the wiring access hole with sealant to prevent foreign particles from entering the indoor unit.

### Using a Conduit

1. Remove the rubber stopper on the indoor unit. Pass the power wiring / communications cable through the conduit, the conduit mounting plate, and to the control panel of the indoor unit.
2. Connect the power wiring / communications cable to the indoor unit terminal block.
3. Screw the conduit mounting plate to the indoor unit.
4. Tighten the conduit and the conduit mounting plate together.

Figure 109: Simplified View of Indoor Unit to Outdoor Unit / Branch Distribution Unit (Multi F MAX systems only) Power Wiring / Communications Cable Connections.

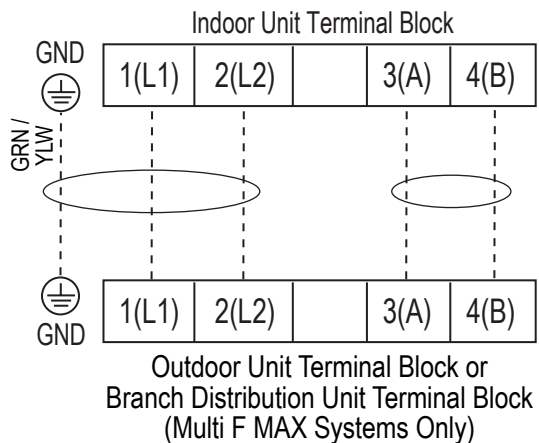
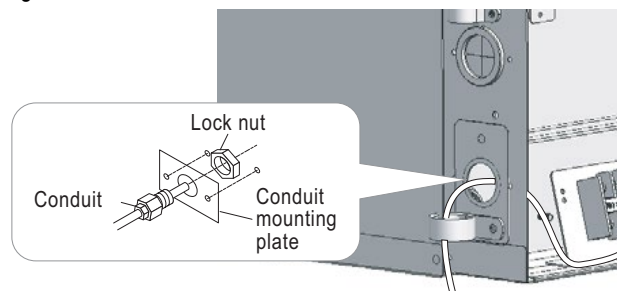


Figure 110: Exterior View of Conduit Installation.



# LOW STATIC DUCT INDOOR UNITS

## Installation and Best Layout Practices

MULTI F  
MULTI F MAX

### Controller Options

Low Static Duct indoor units can be used with many LG-supplied wired controllers (sold separately). The wireless handheld controller (Model No. PWLSSB21H) is also an optional accessory with wired controllers.

#### Wired Controller Connections

Controllers can connect to the indoor unit in one of two different ways.

1. LG Wired Remote Extension Cable with Molex plug (PZCWRC1; sold separately) that connects to the CN-REMO terminal on the indoor unit PCB.
2. Field-supplied controller cable that connects to the indoor unit terminal block (must be at least UL2547 or UL1007, 22 AWG, two-core, one-shield core, at least FT-6 rated if local electric and building codes require plenum cable usage).

Figure 111: PZCWRC1 LG Wired Remote Extension Cable.

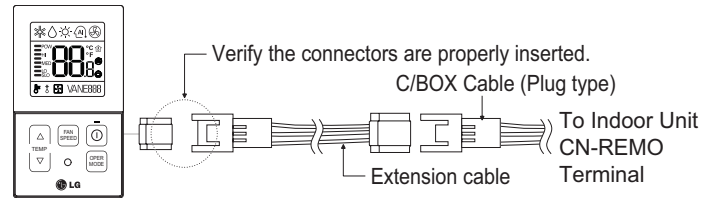
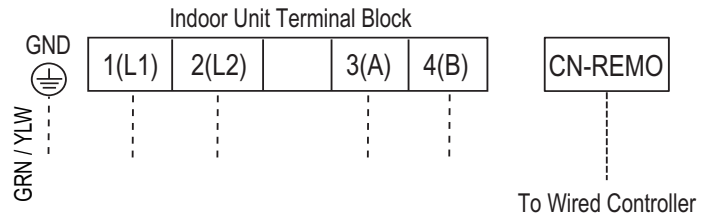


Figure 112: Wired Controller Connections on the Indoor Unit Terminal Block.



#### NOTICE

When using field-supplied controller cable, make sure to connect the yellow to yellow (communications wire), red to red (12V power wire), and black to black (ground wire) terminals from the remote controller to the indoor unit terminal blocks.

Multi F and Multi F MAX Indoor Unit Engineering Manual

### Hanging the Wired Controller

1. The controller wiring / cable can be installed in one of three directions: top, back, or on the right side. If top or right side installation is desired, remove cable guide grooves on the controller, and then position wiring / cable on applicable side.
2. Choose and mark the area of installation, and then screw the wall plate into place (using the provided parts). Install the controller wall plate to fit the electrical box if one is present. Ensure that no gaps exist between the wall plate and the wall itself.
3. Arrange wiring / cables so as not to interfere with the controller circuitry. Position the wired controller on the wall plate. Snap into place by pressing the bottom part of the wired controller onto the wall plate. Make sure that no gaps exist between the wired controller and the wall plate on all sides.
4. To remove wired controller from the wall plate, insert a screwdriver into the two holes at the bottom. Twist screwdriver to release controller. ⚠ Do not damage the controller components when removing.

Figure 113: Removing the Cable Guide Grooves.

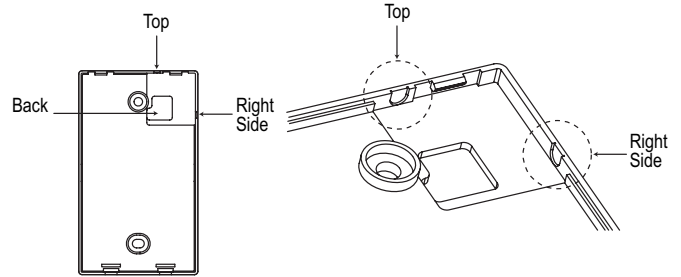
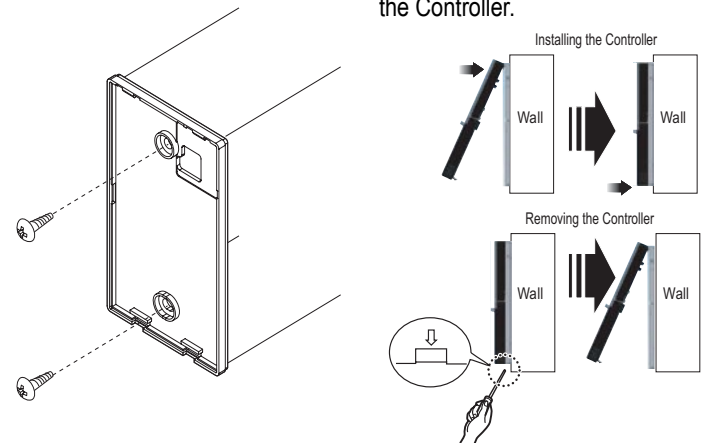


Figure 114: Attaching the Wall Plate. Figure 115: Installing / Removing the Controller.



### Assigning the Thermistor for Temperature Detection

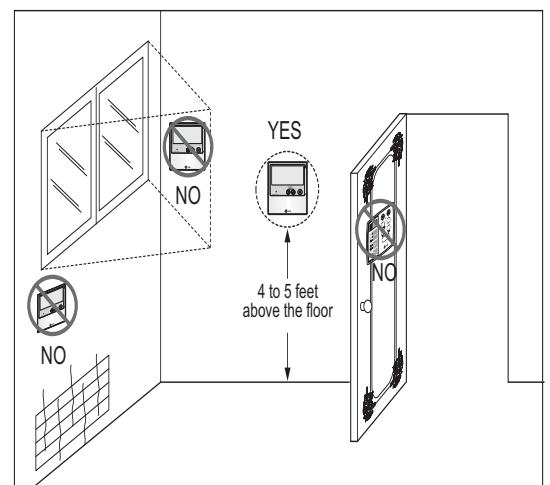
Each indoor unit includes a return air thermistor assigned to sense the temperature. If a wired controller is installed, there is a choice of sensing temperature with either the indoor unit return air thermistor or the thermistor in the wired controller. It is also an option to set both thermistors to sense temperature so that indoor unit bases its operation on the first thermistor to reach the designated temperature differential. For applicable indoor units, an optional Remote Temperature Sensor can be used in lieu of the return air thermistor—either alone or in conjunction with a wired controller thermistor as previously described.

### Wired Controller Placement

Wall indoor units can be used with various wired controllers (optional; sold separately). Wired controllers include a sensor to detect room temperature. To maintain comfort levels in the conditioned space, the wired controller must be installed in a location away from direct sunlight, high humidity, and where it could be directly exposed to cold air. Controller must be installed four (4) to five (5) feet above the floor where its display can be read easily, in an area with good air circulation, and where it can detect an average room temperature.

- ⚠ Do not install the remote controller where it can be impacted by the following:
- Drafts or dead spots behind doors and in corners
  - Hot or cold air from ducts
  - Radiant heat from sun or appliances
  - Concealed pipes and chimneys
  - Uncontrolled areas such as an outside wall behind the remote controller

Figure 116: Proper Location for the Wired Controller.



# LOW STATIC DUCT INDOOR UNITS

## Installation and Best Layout Practices

MULTI F  
MULTI F MAX

### External Static Pressure Control

To provide a required air flow rate that accounts for the external static pressure change, follow the steps below.

1. To access system installer setting mode, press and hold the temperature increase and mode selection buttons simultaneously for approximately three (3) seconds. Choose setting code value "06" by pressing the mode selection button.
2. Use the temperature increase and decrease buttons to select the desired setting value.

Figure 117: Select Code and Set Value.

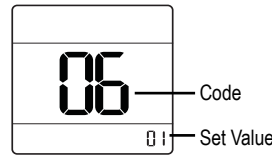
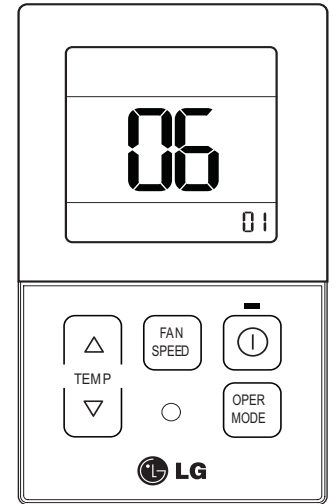


Figure 118: Controller External Static Pressure Setting Display.



#### Setting Values

- 01 : V-H
- 02 : F-H
- 03 : V-L
- 04 : F-L

3. Press the on / off button to save the established settings.
4. To deactivate system installer setting mode after the settings have been established, press and hold the temperature increase and mode selection check buttons simultaneously for approximately three (3) seconds. If a button is not pressed for more than 25 seconds, the system installer setting mode will automatically deactivate.

Table 50: Static Pressure Setting Table.

Pressure Selection		Function	
		Zone State	External Static Pressure Standard Value
01	V-H	Variable	High
02	F-H	Fixed	High
03	V-L	Variable	Low
04	F-L	Fixed	Low

#### NOTICE

- Select the position after verifying duct work and the external static pressure of the indoor unit.
- Factory set to pressure selection F-H.

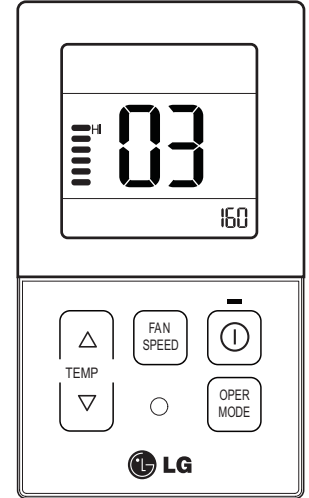
Multi F and Multi F MAX Indoor Unit Engineering Manual

### Assigning Air Flow

To assign an air flow for each fan speed, follow the steps below.

1. To access system installer setting mode, press and hold the temperature increase and mode selection buttons simultaneously for approximately three (3) seconds. Choose setting code value "03" by pressing the mode selection button.
2. Use the fan speed button to select the desired fan speed. ( Lo→Med→Hi will display on the LED).
3. Use the temperature increase and decrease buttons to select the desired external static pressure setting value (thereby assigning the respective airflow). External static pressure value range: 0~255; the value will display near the lower right corner of the LED.
4. Press the on / off button to save the established settings.
5. To deactivate system installer setting mode after the settings have been established, press and hold the temperature increase and mode selection check buttons simultaneously for approximately three (3) seconds. If a button is not pressed for more than 25 seconds, the system installer setting mode will automatically deactivate.

Figure 119: Controller External Static Pressure Setting Display.



### NOTICE

- A trained technician must set the external static pressure value(s). If the external static pressure is set incorrectly, the system will malfunction.
- Do not alter the external static pressure value that corresponds to each air flow level.
- External static pressure value can vary depending on the indoor unit.
- If by pressing the fan speed button during external static pressure setup, the fan speed is raised to the next level, the air flow value of the previous fan speed will be maintained (external static pressure setting value is saved).

# CONVERTIBLE MID STATIC DUCT INDOOR UNIT DATA

**Mechanical Specifications on page 99**

**General Data / Specifications on page 100**

**Dimensions on page 101**

**Cooling Capacity Table on page 102**

**Heating Capacity Table on page 104**

**External Static Pressure on page 106**

**Acoustic Data on page 106**

**Refrigerant Flow Diagrams on page 110**

**Wiring Diagram on page 111**

**Factory Supplied Parts and Materials on page 112**

**Installation and Best Layout Practices on page 113**

### Convertible Mid Static Duct IDU

#### General

All LG indoor units are factory assembled, wired, piped, and provided with a control circuit board, fan, and motor. Convertible Mid Static Duct units are designed for high-speed air volume against an external static pressure up to 0.59"WG.

#### Coil

Indoor unit coils are factory built and are comprised of aluminum fins mechanically bonded to copper tubing. Each unit has two rows of coils, which are pressure tested at the factory. Each unit is provided with a factory installed condensate drain pan below the coil.

#### Refrigerant System

System is designed for use with R32 refrigerant. The refrigeration circuit is pressure-tested at the factory and shipped with a holding charge of helium gas. Refrigerant pipe connections are 45° flare, and all refrigerant lines from the outdoor unit to the indoor units must be field insulated.

#### Electrical

Each indoor unit is designed to operate using 208–230/60/1 power with voltage variances of ±10%.

#### Casing

The casing is designed to mount fully concealed above a finished ceiling or has the flexibility to be installed vertically on the wall in a closet. The vertical up flow configuration installation requires optional installation kit (ABDAMA0) to change the condensate drain pan position suitable for vertical installation.

Casing is manufactured of galvanized steel plate. Cold surfaces of the unit are covered internally with a coated polystyrene insulating material, and covered externally with sheet insulation made of ethylene propylene diene monomer (M-Class) (EPDM). External insulation is plenum rated and conforms to ASTM Standard D-1418. Hanger brackets are included on the casing to support the weight on four corners. Unit has a front horizontal supply air discharge outlet, and one rear horizontal return air inlet which is field-convertible for a rear bottom return.

Return air opening is on the bottom in the vertical position or right end in the horizontal position. Return air plenum sub-base is to be field-provided. The supply air opening is flanged to accept field-installed ductwork that must not exceed the external static pressure limitation of the unit.

#### Fan Assembly and Control

The indoor unit has one direct-drive Sirocco fan made of high strength ABS GP-2200 polymeric resin.

The fan is statically and dynamically balanced, mounted on a common brushless digitally controlled (BLDC) motor, and mounted on vibration-attenuating rubber grommets. Fan speed is controlled using a microprocessor-based direct digital control algorithm. The indoor fan has Low, Med, High, and Auto settings for Cooling mode; and has Low, Med, High, and Auto settings for Heating mode. The Auto setting adjusts the fan speed based on the difference between the controller

#### Features

- Inverter (Variable speed fan)
- Internal drain pump
- Control lock function
- Auto operation
- Auto restart operation
- Dehumidifying function
- Two thermistor control
- External static pressure control
- Group control
- Self-diagnostics function
- Wired controller ordered separately
- Wi-Fi compatible

Figure 120: Multi F Convertible Mid Static Duct Indoor Unit.



set-point and space temperature. Each of the settings can be field-adjusted from the factory setting (RPM / ESP).

#### Air Filter

The return air inlet on the indoor unit includes a factory-supplied removable, washable filter that is accessible from the back of the unit. Options include a return filter box that holds a field-provided high efficiency one or two inch MERV-rated filters.

#### Microprocessor Control

The unit is provided with an integrated control panel to communicate with the outdoor unit. All unit operation parameters are stored in non-volatile memory resident on the unit microprocessor. The microprocessor controls space temperature through using the value provided by the temperature sensor within the indoor unit. The microprocessor control will activate indoor unit operation when the indoor room temperature falls below or rises above a setpoint temperature, at which point, a signal is sent to the outdoor unit to begin the appropriate mode. The microprocessor will also provide self-diagnostics and auto restart functions. A field-supplied three-wire power cable (3 x 14 AWG) and two-wire communications cable (2 x 18 AWG) must be installed to connect the indoor unit(s) to the outdoor unit.

#### R32 Refrigerant Leak Detector

The indoor unit has a built-in R32 refrigerant leak detection sensor designed to communicate with release mitigation devices and third party alarms, and transmit a system error code upon detection of a refrigerant leak or sensor failure / expiration.

#### Shut-off Valve

LG single-port shutoff valve (PRHPZ010A; sold separately) is available as an accessory.

#### Controls

The indoor unit controller of choice must be ordered separately. Communication between the indoor units and the outdoor unit is accomplished through 18 AWG, two-core, stranded and shielded communication cable.

#### Condensate Lift/Pump

The indoor unit is provided with a factory installed and wired internal condensate lift/pump capable of providing a minimum 27.5 inch lift from the bottom surface of the unit. Drain pump has a safety switch to shut off the indoor unit if the condensate rises too high in the drain pan.

# CONVERTIBLE MID STATIC DUCT INDOOR UNITS **MULTI F** **MULTI F MAX**

## General Data / Specifications

Table 51: Multi F Convertible Mid-Static Ducted Indoor Unit General Data.

Model Name	KNUJB091A	KNUJB121A	KNUJB181A	KNUJB241A
Nominal Cooling Capacity (Btu/h) <sup>1</sup>	9,000	12,000	18,000	24,000
Nominal Heating Capacity (Btu/h) <sup>1</sup>	12,000	15,000	20,000	27,000
<i>Operating Range</i>				
Cooling (°F WB)	57-77	57-77	57-77	57-77
Heating (°F DB)	59-81	59-81	59-81	59-81
<i>Fan</i>				
Type	Sirocco	Sirocco	Sirocco	Sirocco
Motor Output (W) x Qty.	165 x 1	165 x 1	165 x 1	165 x 1
Motor/Drive	Brushless Digitally Controlled / Direct	Brushless Digitally Controlled / Direct	Brushless Digitally Controlled / Direct	Brushless Digitally Controlled / Direct
Factory Set Airflow Rate CFM (H/M/L)	353.1 / 317.8 / 282.5	494.4 / 423.8 / 353.1	635.7 / 529.7 / 423.8	706.3 / 547.4 / 459.1
Factory Set External Static Pressure (in. wg)	0.24	0.24	0.24	0.24
Maximum External Static Pressure (in. wg)	0.59	0.59	0.59	0.59
<i>Unit Data</i>				
Refrigerant Type <sup>2</sup>	R32	R32	R32	R32
Refrigerant Control	EEV	EEV	EEV	EEV
Power Supply V, Ø, Hz <sup>3</sup>	208-230, 1, 60	208-230, 1, 60	208-230, 1, 60	208-230, 1, 60
Rated Amps (A)	1.7	1.7	1.7	1.7
Sound Pressure Level (Standard Mode) dB(A) H/M/L <sup>4</sup>	28 / 27 / 26	31 / 29 / 28	36 / 32 / 29	38 / 33 / 30
Sound Power dB(A)	44	47	54	57
Dimensions (W x H x D, in.)	35-7/16 x 9-21/32 x 27-9/16	35-7/16 x 9-21/32 x 27-9/16	35-7/16 x 9-21/32 x 27-9/16	35-7/16 x 9-21/32 x 27-9/16
IDU Net / Ship Weight (lbs.)	61.5 / 71.7	61.5 / 71.7	61.5 / 71.7	64.2 / 74.3
Vertical Install Kit Net / Ship Weight (lbs.)	4.41 / 5.51	4.41 / 5.51	4.41 / 5.51	4.41 / 5.51
Power Wiring Cable (No. x AWG) <sup>5</sup>	3 x 14	3 x 14	3 x 14	3 x 14
Communications Wiring Cable (No. x AWG) <sup>5</sup>	2 x 18	2 x 18	2 x 18	2 x 18
Heat Exchanger (Row x Column x Fin / inch) x Number	(2 x 13 x 18) x 1	(2 x 13 x 18) x 1	(2 x 13 x 18) x 1	(3 x 13 x 18) x 1
Dehumidification Rate (pts./hr)	0.35	1.27	2.75	4.23
<i>Pipe Size</i>				
Liquid (in.)	1/4	1/4	1/4	1/4
Vapor (in.)	3/8	3/8	1/2	1/2
<i>Connection Size</i>				
Liquid (in.)	1/4	1/4	1/4	3/8
Vapor (in.)	3/8	3/8	1/2	5/8
Drain O.D. / I.D. (in.)	1-1/4, 1	1-1/4, 1	1-1/4, 1	1-1/4, 1

<sup>1</sup>Nominal capacity is rated 0 ft. above sea level with corresponding refrigerant piping length in accordance with standard length of each outdoor unit and a 0 ft. level difference between outdoor and indoor units. All capacities are net with a combination ratio between 95 – 105%.

Nominal cooling capacity rating obtained with air entering the indoor unit at 80°F dry bulb (DB) and 67°F wet bulb (WB) and outdoor ambient conditions of 95°F dry bulb (DB) and 75°F wet bulb (WB). Nominal heating capacity rating obtained with air entering the indoor unit at 70°F dry bulb (DB) and 60°F wet bulb (WB) and outdoor ambient conditions of 47°F dry bulb (DB) and 43°F wet bulb (WB).

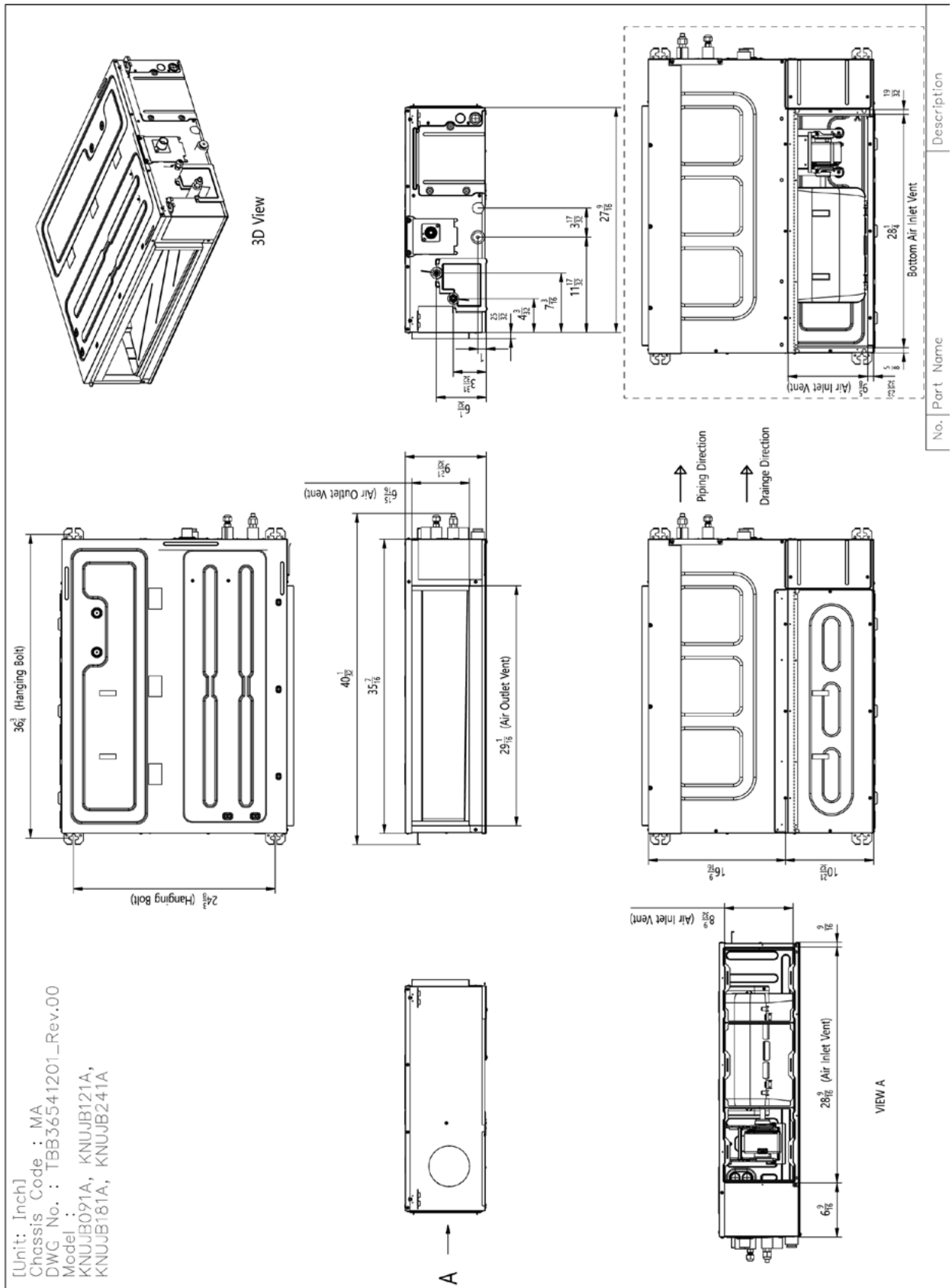
<sup>2</sup>This unit comes with a dry helium charge.

<sup>3</sup>Acceptable operating voltage: 187V-253V.

<sup>4</sup>Sound pressure levels are tested in an anechoic chamber under ISO Standard 3745 and are the same in both cooling and heating mode. These values can increase due to ambient conditions during operation.

<sup>5</sup>The power wiring and the communication wiring from the outdoor unit to the indoor unit, or from the branch distribution unit to the indoor unit is field supplied and must be stranded, shielded or unshielded (if shielded, it must be grounded to the chassis of the outdoor unit only). All wiring must comply with applicable local and national codes.

Figure 121: Multi F Convertible Mid Static Duct Indoor Unit Dimensions.



[Unit: Inch]  
 Chassis Code : MA  
 DWG No. : TBB36541201\_Rev.00  
 Model : KNUJB091A, KNUJB121A,  
 KNUJB181A, KNUJB241A

# CONVERTIBLE MID STATIC DUCT INDOOR UNITS <sup>MULTI F</sup> <sup>MULTI F</sup> MAX

## Cooling Capacity Table

Table 52: Multi F Convertible Mid Static Duct Indoor Units KNUJB091A, KNUJB121A Cooling Capacity Table.

Model No. / Nominal Capacity of Indoor Unit (Btu/h)	Outdoor Air Temp. (°F DB)	Indoor Air Temp. °F DB / °F WB											
		68 / 57		73 / 61		77 / 64		80 / 67		86 / 72		90 / 75	
		TC	SHC	TC	SHC	TC	SHC	TC	SHC	TC	SHC	TC	SHC
KNUJB091A 9,000	-4	8.85	5.84	9.40	6.17	9.95	5.97	10.34	6.10	11.05	6.15	11.60	6.27
	-0.4	8.84	5.88	9.39	6.21	9.94	6.01	10.34	6.14	11.04	6.19	11.59	6.31
	5	8.84	5.93	9.38	6.26	9.93	6.06	10.33	6.19	11.03	6.24	11.58	6.36
	10	8.83	5.97	9.38	6.31	9.93	6.11	10.32	6.24	11.02	6.29	11.57	6.41
	15	8.82	6.02	9.37	6.36	9.92	6.16	10.31	6.29	11.01	6.34	11.56	6.46
	20	8.82	6.07	9.36	6.41	9.91	6.21	10.31	6.34	11.01	6.39	11.55	6.51
	25	8.81	6.12	9.36	6.46	9.90	6.25	10.30	6.39	11.00	6.44	11.54	6.56
	30	8.80	6.16	9.35	6.51	9.90	6.30	10.29	6.44	10.99	6.49	11.54	6.61
	35	8.80	6.21	9.34	6.56	9.89	6.35	10.28	6.48	10.98	6.54	11.53	6.66
	40	8.79	6.26	9.33	6.61	9.88	6.40	10.27	6.53	10.97	6.59	11.52	6.71
	45	8.78	6.30	9.33	6.66	9.87	6.45	10.27	6.58	10.96	6.64	11.51	6.76
	50	8.78	6.35	9.32	6.71	9.87	6.49	10.26	6.63	10.96	6.69	11.50	6.81
	55	8.77	6.40	9.31	6.76	9.86	6.54	10.25	6.68	10.95	6.74	11.49	6.86
	60	8.76	6.44	9.31	6.80	9.85	6.59	10.24	6.73	10.94	6.78	11.48	6.91
	65	8.76	6.49	9.30	6.85	9.84	6.64	10.24	6.78	10.93	6.83	11.47	6.96
	70	8.75	6.53	9.29	6.90	9.84	6.68	10.23	6.82	10.92	6.88	11.47	7.01
	75	8.75	6.58	9.28	6.95	9.83	6.73	10.22	6.87	10.91	6.93	11.46	7.06
	80	8.74	6.62	9.27	7.00	9.82	6.78	10.21	6.92	10.90	6.98	11.45	7.11
	85	8.73	6.66	9.26	7.05	9.81	6.83	10.20	6.97	10.89	7.03	11.44	7.16
	90	8.72	6.70	9.25	7.10	9.80	6.88	10.19	7.02	10.88	7.08	11.43	7.21
	95	8.71	6.74	9.24	7.15	9.79	6.93	10.18	7.07	10.87	7.13	11.42	7.26
	100	8.70	6.78	9.23	7.20	9.78	6.98	10.17	7.12	10.86	7.18	11.41	7.31
105	8.69	6.82	9.22	7.25	9.77	7.03	10.16	7.17	10.85	7.23	11.40	7.36	
110	8.68	6.86	9.21	7.30	9.76	7.08	10.15	7.22	10.84	7.28	11.39	7.41	
115	8.67	6.90	9.20	7.35	9.75	7.13	10.14	7.27	10.83	7.33	11.38	7.46	
118	8.66	6.94	9.19	7.40	9.74	7.18	10.13	7.32	10.82	7.38	11.37	7.51	
122	8.65	6.98	9.18	7.45	9.73	7.23	10.12	7.37	10.81	7.43	11.36	7.56	
KNUJB121A 12,000	-4	11.80	8.12	12.53	8.58	13.26	8.31	13.79	8.48	14.73	8.55	15.46	8.72
	-0.4	11.79	8.17	12.52	8.63	13.26	8.36	13.78	8.53	14.72	8.60	15.45	8.77
	5	11.78	8.24	12.51	8.71	13.24	8.43	13.77	8.61	14.71	8.68	15.44	8.84
	10	11.77	8.31	12.50	8.77	13.23	8.50	13.76	8.68	14.70	8.75	15.43	8.91
	15	11.76	8.37	12.49	8.84	13.22	8.56	13.75	8.74	14.69	8.82	15.42	8.98
	20	11.75	8.44	12.48	8.91	13.21	8.63	13.74	8.81	14.67	8.89	15.40	9.05
	25	11.75	8.50	12.48	8.98	13.20	8.70	13.73	8.88	14.66	8.96	15.39	9.12
	30	11.74	8.57	12.47	9.05	13.19	8.76	13.72	8.95	14.65	9.02	15.38	9.19
	35	11.73	8.63	12.46	9.12	13.18	8.83	13.71	9.02	14.64	9.09	15.37	9.26
	40	11.72	8.70	12.45	9.19	13.17	8.90	13.70	9.08	14.63	9.16	15.36	9.33
	45	11.71	8.76	12.44	9.26	13.16	8.96	13.69	9.15	14.62	9.23	15.35	9.40
	50	11.70	8.83	12.43	9.33	13.15	9.03	13.68	9.22	14.61	9.30	15.33	9.47
	55	11.69	8.89	12.42	9.39	13.14	9.10	13.67	9.29	14.60	9.37	15.32	9.54
	60	11.68	8.96	12.41	9.46	13.13	9.16	13.66	9.35	14.59	9.43	15.31	9.61
	65	11.67	9.02	12.40	9.53	13.12	9.23	13.65	9.42	14.57	9.50	15.30	9.68
	70	11.66	9.09	12.39	9.60	13.11	9.29	13.64	9.49	14.56	9.57	15.29	9.75
	75	11.38	8.94	12.11	9.45	12.83	9.16	13.35	9.36	14.27	9.45	15.00	9.64
	80	11.10	8.78	11.82	9.30	12.55	9.03	13.07	9.23	13.99	9.33	14.71	9.53
	85	10.83	8.62	11.54	9.15	12.26	8.89	12.78	9.10	13.70	9.21	14.42	9.41
	90	10.55	8.46	11.26	8.99	11.98	8.74	12.50	8.96	13.42	9.08	14.13	9.28
	95	10.25	8.37	10.96	8.91	11.67	8.68	12.00	8.76	13.10	9.03	13.81	9.24
	100	10.00	8.15	10.71	8.68	11.42	8.47	11.84	8.62	12.85	8.84	13.56	9.05
105	9.75	7.92	10.46	8.46	11.17	8.26	11.69	8.49	12.60	8.64	13.31	8.86	
110	9.50	7.65	10.21	8.18	10.92	8.01	11.44	8.24	12.35	8.40	13.07	8.62	
115	9.25	7.42	9.96	7.95	10.67	7.80	11.19	8.03	12.10	8.20	12.82	8.42	
118	9.10	7.37	9.81	7.91	10.52	7.76	11.04	7.99	11.95	8.17	12.67	8.40	
122	9.05	7.35	9.76	7.89	10.48	7.74	10.99	7.98	11.90	8.16	12.62	8.39	

TC = Total Capacity (kBtu/h).

SHC: Sensible Heat Capacity (kBtu/h).

Nominal capacity as rated 0 ft. above sea level and a 0 ft. level difference between outdoor and indoor units. Corresponding refrigerant piping length is accordance with standard length of each outdoor unit.

Nominal cooling capacity rating obtained with air entering the indoor unit at 80°F dry bulb (DB) and 67°F wet bulb (WB), and outdoor ambient conditions of 95°F dry bulb (DB) and 75°F wet bulb (WB).

The shaded table columns and rows indicate reference data. When operating at this temperature, these values can be different if the system is not running consistently.

Table 53: Multi F Convertible Mid Static Duct Indoor Units KNUJB181A, KNUJB241A Cooling Capacity Table.

Model No. / Nominal Capacity of Indoor Unit (Btu/h)	Outdoor Air Temp. (°F DB)	Indoor Air Temp. °F DB / °F WB											
		68 / 57		73 / 61		77 / 64		80 / 67		86 / 72		90 / 75	
		TC	SHC	TC	SHC	TC	SHC	TC	SHC	TC	SHC	TC	SHC
KNUJB181A 18,000	-4	17.70	12.85	18.80	13.58	19.89	13.14	20.69	13.42	22.09	13.53	23.19	13.79
	-0.4	17.69	12.93	18.79	13.66	19.88	13.22	20.68	13.50	22.08	13.61	23.18	13.87
	5	17.67	13.04	18.77	13.77	19.87	13.34	20.66	13.62	22.06	13.73	23.16	13.99
	10	17.66	13.14	18.76	13.88	19.85	13.44	20.64	13.73	22.05	13.84	23.14	14.10
	15	17.65	13.25	18.74	13.99	19.84	13.55	20.63	13.83	22.03	13.95	23.12	14.22
	20	17.63	13.35	18.73	14.10	19.82	13.65	20.61	13.94	22.01	14.06	23.11	14.33
	25	17.62	13.45	18.71	14.21	19.81	13.76	20.60	14.05	22.00	14.17	23.09	14.44
	30	17.60	13.56	18.70	14.32	19.79	13.87	20.58	14.16	21.98	14.28	23.07	14.55
	35	17.59	13.66	18.68	14.43	19.78	13.97	20.57	14.27	21.96	14.39	23.05	14.66
	40	17.58	13.76	18.67	14.54	19.76	14.08	20.55	14.37	21.94	14.49	23.04	14.77
	45	17.56	13.87	18.66	14.65	19.75	14.18	20.53	14.48	21.93	14.60	23.02	14.88
	50	17.55	13.97	18.64	14.75	19.73	14.29	20.52	14.59	21.91	14.71	23.00	14.99
	55	17.54	14.07	18.63	14.86	19.72	14.39	20.50	14.69	21.89	14.82	22.98	15.10
	60	17.52	14.17	18.61	14.97	19.70	14.50	20.49	14.80	21.88	14.93	22.97	15.21
	65	17.51	14.27	18.60	15.08	19.69	14.60	20.47	14.91	21.86	15.03	22.95	15.32
	70	17.50	14.38	18.58	15.19	19.67	14.70	20.46	15.01	21.84	15.14	22.93	15.43
	75	17.08	14.14	18.16	14.96	19.24	14.50	20.03	14.81	21.41	14.96	22.50	15.25
	80	16.66	13.90	17.74	14.72	18.82	14.29	19.60	14.61	20.98	14.77	22.06	15.07
	85	16.24	13.64	17.32	14.47	18.40	14.06	19.17	14.39	20.55	14.57	21.63	14.88
	90	15.82	13.39	16.90	14.22	17.97	13.84	18.75	14.17	20.12	14.36	21.20	14.69
	95	15.37	13.25	16.44	14.09	17.51	13.73	<b>18.00</b>	<b>13.86</b>	19.65	14.29	20.72	14.62
100	14.99	12.89	16.06	13.74	17.13	13.40	17.77	13.65	19.28	13.98	20.35	14.32	
105	14.62	12.54	15.69	13.38	16.76	13.08	17.53	13.43	18.90	13.67	19.97	14.02	
110	14.24	12.11	15.32	12.95	16.39	12.67	17.16	13.03	18.53	13.29	19.60	13.64	
115	13.87	11.75	14.94	12.58	16.01	12.34	16.79	12.70	18.15	12.97	19.22	13.33	
118	13.65	11.66	14.72	12.51	15.79	12.27	16.56	12.64	17.93	12.92	19.00	13.29	
122	13.57	11.63	14.64	12.48	15.71	12.25	16.49	12.62	17.85	12.91	18.92	13.28	
KNUJB241A 24,000	-4	23.60	17.14	25.06	18.10	26.53	17.53	27.58	17.90	29.46	18.05	30.92	18.39
	-0.4	23.58	17.24	25.05	18.21	26.51	17.63	27.57	18.00	29.44	18.15	30.91	18.50
	5	23.56	17.39	25.03	18.37	26.49	17.78	27.55	18.16	29.42	18.31	30.88	18.66
	10	23.55	17.52	25.01	18.51	26.47	17.92	27.53	18.30	29.39	18.46	30.86	18.81
	15	23.53	17.66	24.99	18.66	26.45	18.07	27.50	18.45	29.37	18.60	30.83	18.95
	20	23.51	17.80	24.97	18.80	26.43	18.21	27.48	18.59	29.35	18.75	30.81	19.10
	25	23.49	17.94	24.95	18.95	26.41	18.35	27.46	18.73	29.33	18.89	30.79	19.25
	30	23.47	18.08	24.93	19.09	26.39	18.49	27.44	18.88	29.30	19.04	30.76	19.40
	35	23.46	18.21	24.91	19.24	26.37	18.63	27.42	19.02	29.28	19.18	30.74	19.54
	40	23.44	18.35	24.89	19.38	26.35	18.77	27.40	19.16	29.26	19.33	30.72	19.69
	45	23.42	18.49	24.87	19.53	26.33	18.91	27.38	19.31	29.24	19.47	30.69	19.84
	50	23.40	18.62	24.85	19.67	26.31	19.05	27.36	19.45	29.21	19.61	30.67	19.99
	55	23.38	18.76	24.84	19.82	26.29	19.19	27.34	19.59	29.19	19.76	30.64	20.13
	60	23.37	18.90	24.82	19.96	26.27	19.33	27.32	19.73	29.17	19.90	30.62	20.28
	65	23.35	19.03	24.80	20.10	26.25	19.47	27.29	19.88	29.15	20.04	30.60	20.42
	70	23.33	19.17	24.78	20.25	26.23	19.61	27.27	20.02	29.13	20.19	30.57	20.57
	75	22.77	18.85	24.21	19.94	25.66	19.33	26.70	19.75	28.55	19.94	29.99	20.34
	80	22.21	18.53	23.65	19.63	25.09	19.05	26.13	19.48	27.97	19.69	29.42	20.10
	85	21.65	18.19	23.09	19.30	24.53	18.75	25.57	19.19	27.40	19.43	28.84	19.84
	90	21.09	17.85	22.53	18.96	23.96	18.45	25.00	18.90	26.83	19.15	28.27	19.59
	95	20.49	17.66	21.92	18.79	23.35	18.31	<b>24.00</b>	<b>18.48</b>	26.20	19.05	27.63	19.50
100	19.99	17.19	21.42	18.31	22.85	17.87	23.69	18.19	25.70	18.64	27.13	19.10	
105	19.49	16.71	20.92	17.84	22.35	17.43	23.38	17.91	25.20	18.23	26.63	18.70	
110	18.99	16.14	20.42	17.26	21.85	16.90	22.88	17.37	24.70	17.71	26.13	18.19	
115	18.49	15.66	19.92	16.78	21.35	16.45	22.38	16.93	24.20	17.29	25.63	17.77	
118	18.19	15.55	19.62	16.68	21.05	16.36	22.08	16.86	23.90	17.23	25.33	17.72	
122	18.10	15.51	19.52	16.64	20.95	16.34	21.98	16.83	23.81	17.21	25.23	17.71	

Convertible Mid Static Duct

TC = Total Capacity (kBtu/h).

SHC: Sensible Heat Capacity (kBtu/h).

Nominal capacity as rated 0 ft. above sea level and a 0 ft. level difference between outdoor and indoor units. Corresponding refrigerant piping length is accordance with standard length of each outdoor unit.

Nominal cooling capacity rating obtained with air entering the indoor unit at 80°F dry bulb (DB) and 67°F wet bulb (WB), and outdoor ambient conditions of 95°F dry bulb (DB) and 75°F wet bulb (WB).

The shaded table columns and rows indicate reference data. When operating at this temperature, these values can be different if the system is not running consistently.

# CONVERTIBLE MID STATIC DUCT INDOOR UNITS **MULTI F** **MULTI F MAX**

## Heating Capacity Table

Table 54: Multi F Convertible Mid Static Duct Indoor Units KNUJB091A, KNUJB121A Heating Capacity Table.

Model No. / Nominal Capacity of Indoor Unit (Btu/h)	Outdoor Air Temp.		Indoor Air Temp. °F DB					
	°F DB	°F WB	61	64	68	70	72	75
			TC	TC	TC	TC	TC	TC
KNUJB091A 9,000	-13	-13.4	2.20	2.15	2.09	2.05	2.02	1.95
	-4	-4.4	3.84	3.75	3.64	3.59	3.54	3.41
	0	-0.4	4.64	4.54	4.41	4.34	4.28	4.13
	5	4.5	5.65	5.53	5.37	5.28	5.21	5.02
	10	9	7.04	6.88	6.68	6.57	6.49	6.25
	17	15	8.88	8.69	8.44	<b>8.30</b>	8.19	7.89
	20	19	9.45	9.24	8.98	8.83	8.71	8.39
	25	23	10.02	9.79	9.51	9.36	9.23	8.90
	30	28	10.72	10.48	10.18	10.02	9.88	9.53
	35	32	11.29	11.04	10.72	10.55	10.41	10.03
	40	36	11.86	11.59	11.26	11.08	10.93	10.53
	45	41	12.56	12.28	11.93	11.74	11.58	11.16
	47	43	12.85	12.56	12.20	<b>12.00</b>	11.84	11.41
	50	46	12.88	12.62	12.31	12.13	11.99	11.58
	55	51	12.95	12.73	12.50	12.35	12.24	11.88
	60	56	13.01	12.84	12.68	12.57	12.49	12.17
63	59	13.05	12.90	12.79	12.71	12.64	12.34	
68	64	13.08	12.97	12.90	12.84	12.79	12.52	
KNUJB121A 12,000	-13	-13.4	2.86	2.30	2.50	2.53	2.55	2.39
	-4	-4.4	6.18	5.69	5.68	5.62	5.57	5.32
	0	-0.4	7.65	7.18	7.07	6.98	6.90	6.61
	5	4.5	9.32	8.88	8.68	8.53	8.43	8.09
	10	9	10.33	9.92	9.64	9.47	9.34	8.97
	17	15	11.33	10.94	10.59	<b>10.40</b>	10.25	9.85
	20	19	11.96	11.58	11.19	10.98	10.81	10.41
	25	23	12.97	12.58	12.15	11.91	11.73	11.29
	30	28	13.94	13.50	13.04	12.80	12.61	12.15
	35	32	14.85	14.38	13.89	13.64	13.44	12.96
	40	36	15.27	14.84	14.37	14.12	13.92	13.42
	45	41	15.84	15.46	15.01	14.76	14.56	14.03
	47	43	16.06	15.70	15.25	<b>15.00</b>	14.80	14.27
	50	46	16.10	15.78	15.39	15.17	14.99	14.48
	55	51	16.19	15.92	15.62	15.44	15.30	14.84
	60	56	16.26	16.05	15.86	15.71	15.61	15.21
63	59	16.31	16.13	15.99	15.89	15.80	15.43	
68	64	16.36	16.22	16.13	16.05	15.98	15.65	

TC = Total Capacity (kBtu/h).

Nominal capacity as rated 0 ft. above sea level and a 0 ft. level difference between outdoor and indoor units. Corresponding refrigerant piping length is accordance with standard length of each outdoor unit.  
Nominal heating capacity rating obtained with air entering the indoor unit at 70°F dry bulb (DB) and 60°F wet bulb (WB), and outdoor ambient conditions of 47°F dry bulb (DB) and 43°F wet bulb (WB).

Table 55: Multi F Convertible Mid Static Duct Indoor Units KNUJB181A, KNUJB241A Heating Capacity Table.

Model No. / Nominal Capacity of Indoor Unit (Btu/h)	Outdoor Air Temp.		Indoor Air Temp. °F DB					
	°F DB	°F WB	61	64	68	70	72	75
			TC	TC	TC	TC	TC	TC
KNUJB181A 18,000	-13	-13.4	3.09	2.49	2.71	2.74	2.76	2.58
	-4	-4.4	6.88	6.33	6.32	6.25	6.20	5.92
	0	-0.4	8.62	8.09	7.97	7.87	7.77	7.45
	5	4.5	10.67	10.17	9.93	9.77	9.65	9.26
	10	9	12.03	11.55	11.22	11.03	10.88	10.45
	17	15	13.51	13.04	12.62	<b>12.40</b>	12.22	11.75
	20	19	14.41	13.95	13.49	13.23	13.03	12.54
	25	23	15.91	15.43	14.90	14.61	14.39	13.84
	30	28	17.41	16.87	16.29	15.99	15.76	15.17
	35	32	18.90	18.30	17.68	17.35	17.10	16.49
	40	36	19.81	19.25	18.64	18.32	18.06	17.41
	45	41	20.95	20.45	19.85	19.52	19.26	18.56
	47	43	21.41	20.93	20.33	<b>20.00</b>	19.73	19.02
	50	46	21.47	21.04	20.52	20.22	19.98	19.31
	55	51	21.58	21.22	20.83	20.59	20.40	19.79
	60	56	21.68	21.40	21.14	20.95	20.81	20.28
63	59	21.74	21.51	21.32	21.18	21.06	20.57	
68	64	21.81	21.62	21.51	21.40	21.31	20.86	
KNUJB241A 24,000	-13	-13.4	4.54	3.66	3.98	4.02	4.06	3.80
	-4	-4.4	9.99	9.20	9.19	9.08	9.01	8.60
	0	-0.4	12.45	11.70	11.52	11.37	11.24	10.76
	5	4.5	15.31	14.59	14.26	14.02	13.85	13.29
	10	9	17.14	16.46	16.00	15.72	15.50	14.89
	17	15	19.06	18.40	17.82	<b>17.50</b>	17.24	16.58
	20	19	20.25	19.61	18.95	18.59	18.31	17.63
	25	23	22.20	21.53	20.78	20.39	20.08	19.31
	30	28	24.11	23.36	22.56	22.14	21.82	21.01
	35	32	25.99	25.16	24.30	23.86	23.51	22.67
	40	36	27.02	26.27	25.44	25.00	24.64	23.75
	45	41	28.37	27.70	26.88	26.43	26.08	25.13
	47	43	28.90	28.26	27.45	<b>27.00</b>	26.64	25.68
	50	46	28.98	28.40	27.70	27.30	26.97	26.07
	55	51	29.13	28.65	28.12	27.80	27.54	26.72
	60	56	29.27	28.89	28.54	28.28	28.09	27.38
63	59	29.35	29.04	28.78	28.59	28.43	27.77	
68	64	29.44	29.19	29.04	28.89	28.77	28.16	

Convertible Mid Static Duct

TC = Total Capacity (kBtu/h).

Nominal capacity as rated 0 ft. above sea level and a 0 ft. level difference between outdoor and indoor units. Corresponding refrigerant piping length is accordance with standard length of each outdoor unit.  
Nominal heating capacity rating obtained with air entering the indoor unit at 70°F dry bulb (DB) and 60°F wet bulb (WB), and outdoor ambient conditions of 47°F dry bulb (DB) and 43°F wet bulb (WB).

# CONVERTIBLE MID STATIC DUCT INDOOR UNITS <sup>MULTI F</sup> <sup>MULTI F</sup> MAX

External Static Pressure / Acoustic Data

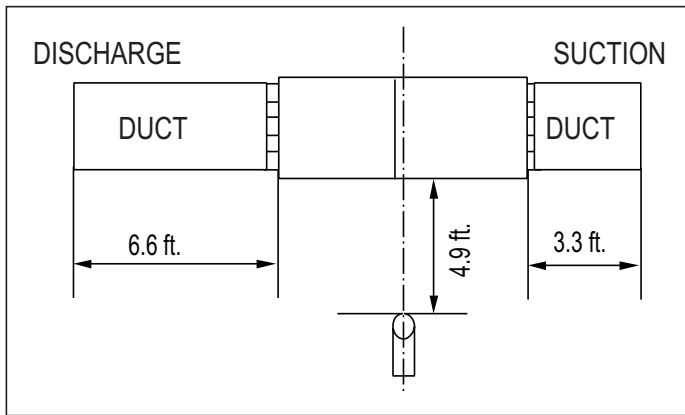
Table 56: Multi F Convertible Mid Static Duct External Static Pressure Setting Values Table.

Static Pressure (in. wg)			0.1	0.16	0.2	0.24	0.28	0.31	0.35	0.39	0.43	0.51	0.59
Model No. / Nominal Capacity of Indoor Unit (Btu/h)	Airflow Rate / CFM		Setting Value (in. wg)										
	KNUJB091A 9,000	High	353.1	76	88	96	99	104	110	115	121	126	135
Mid		317.8	72	82	92	95	100	106	111	117	121	131	139
Low		282.5	68	78	88	91	96	102	107	113	117	127	135
KNUJB121A 12,000	High	494.4	91	98	105	108	113	118	122	130	134	143	151
	Mid	423.8	82	92	100	103	108	114	118	126	130	139	147
	Low	353.1	76	88	96	99	104	110	114	121	126	135	143
KNUJB181A 18,000	High	635.7	106	113	117	121	126	128	133	137	139	149	156
	Mid	529.7	94	102	108	109	115	119	122	130	134	145	152
	Low	423.8	82	92	100	103	108	114	118	126	130	139	147
KNUJB241A 24,000	High	706.3	122	128	131	132	136	143	146	148	152	158	164
	Mid	547.4	103	110	114	117	121	127	130	135	138	145	154
	Low	459.1	93	100	105	109	114	118	122	128	131	139	146

**NOTICE**

- To get the desired air flow and external static pressure combination, use the setting value from the table. Using a setting value other than that listed in the table will not provide the desired combination.
- Table data is based at 230V. Air flow rate varies according to voltage fluctuation.

Figure 122: Sound Pressure Level Measurement Location.

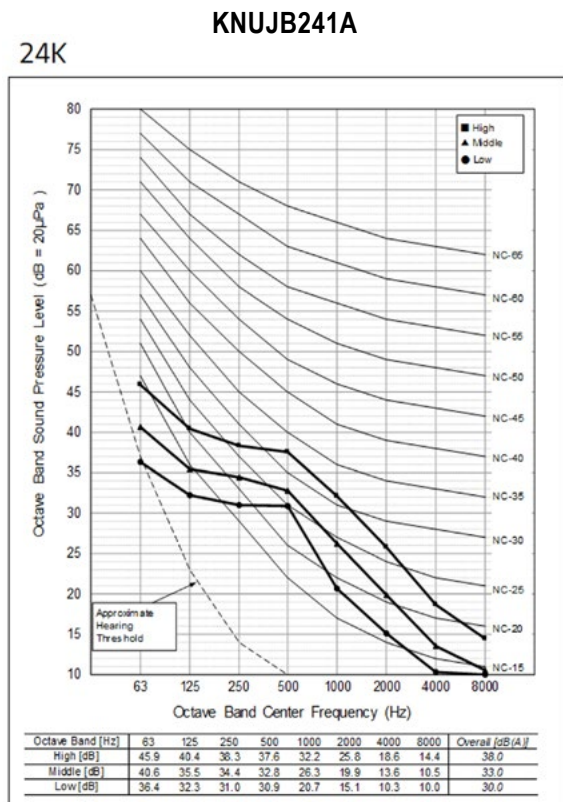
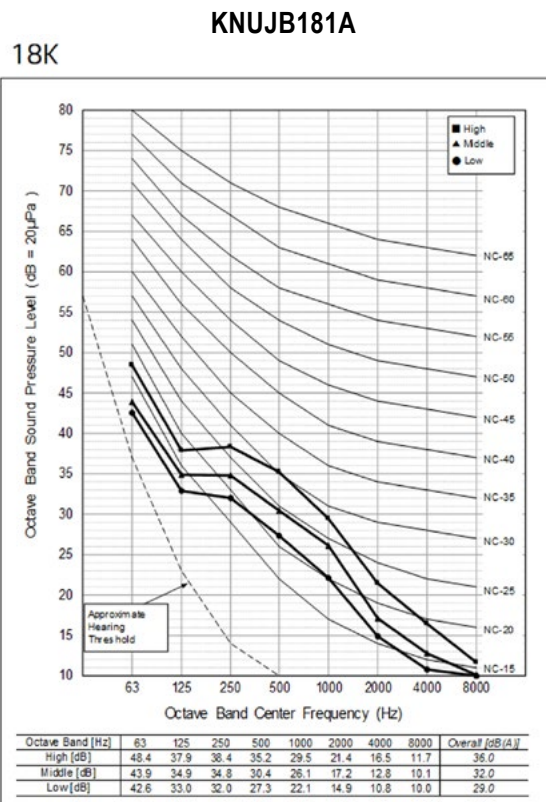
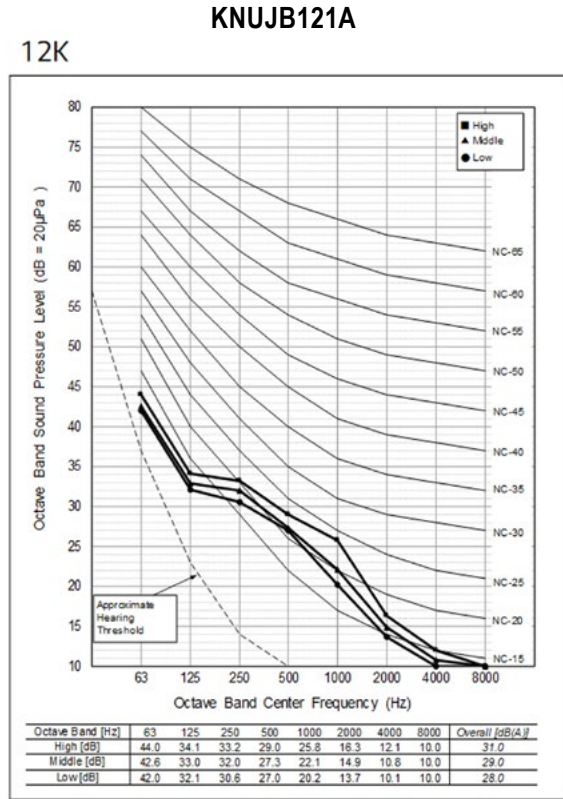
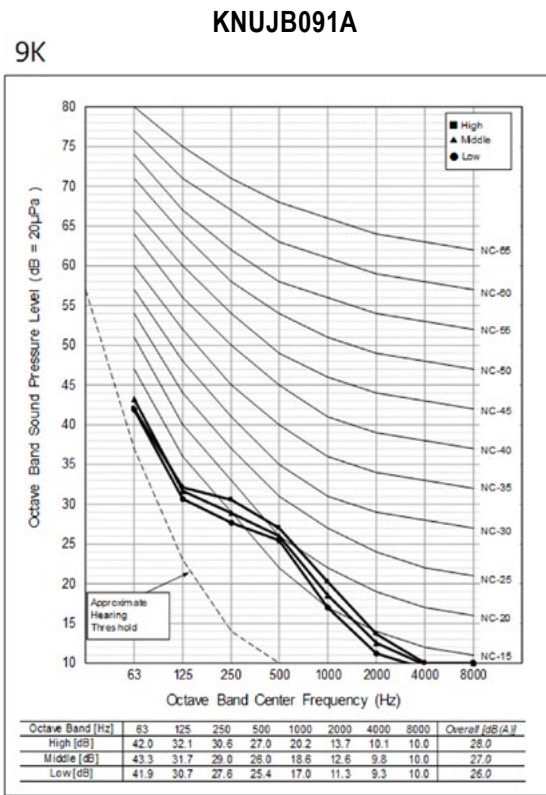


- Measurements taken with no attenuation and units operating at full load normal operating condition.
- Sound level will vary depending on a range of factors such as construction (acoustic absorption coefficient) of particular area in which the equipment is installed.
- Sound power levels are measured in dB(A).
- Tested in anechoic chamber per ISO Standard 3745.

Table 57: Multi F Convertible Mid Static Duct Sound Pressure Levels (dB[A]).

Model No.	Sound Pressure Levels (dB[A]) (Cooling and Heating)		
	High Fan Speed	Medium Fan Speed	Low Fan Speed
KNUJB241A	38	33	30
KNUJB181A	36	32	29
KNUJB121A	31	29	28
KNUJB091A	28	27	26

Figure 123: Multi F Convertible Mid Static Duct Sound Pressure Level Diagrams.



# CONVERTIBLE MID STATIC DUCT INDOOR UNITS <sup>MULTI F</sup> <sup>MULTI F MAX</sup>

## Acoustic Data

Table 58: Multi F Convertible Mid Static Duct Indoor Unit Sound Power Levels.

Indoor Unit Model MA Frames	Sound Power Levels dB(A)
	High Fan Speed
KNUJB091A	44
KNUJB121A	47
KNUJB181A	54
KNUJB241A	57

Figure 124: Sound Power Level Diagrams, KNUJB091A, KNUJB121A.

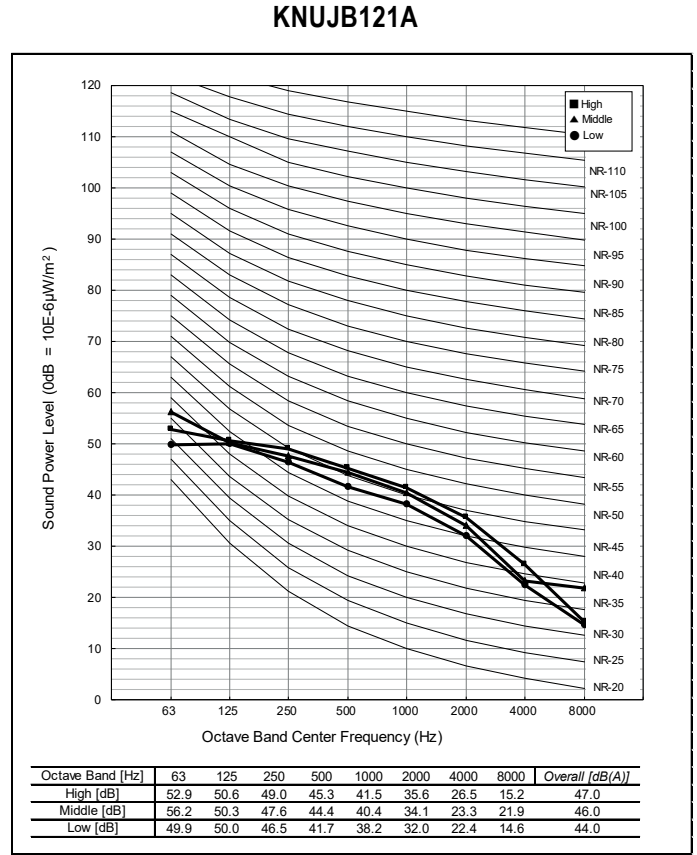
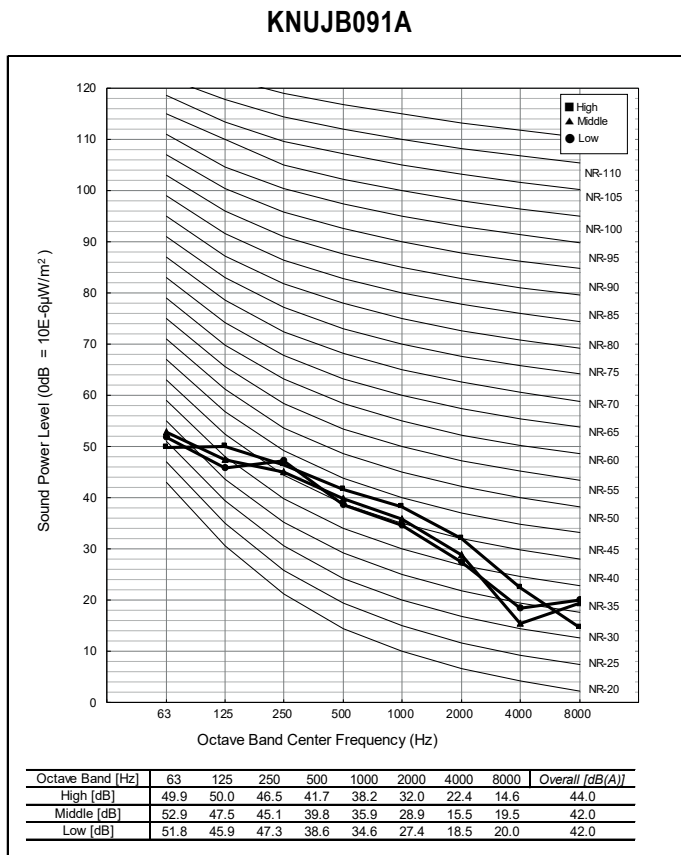
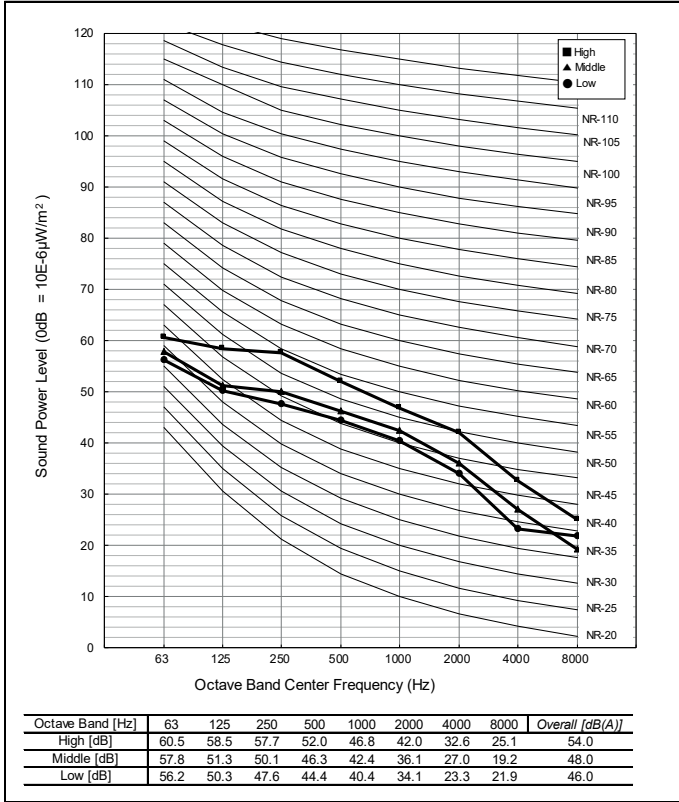
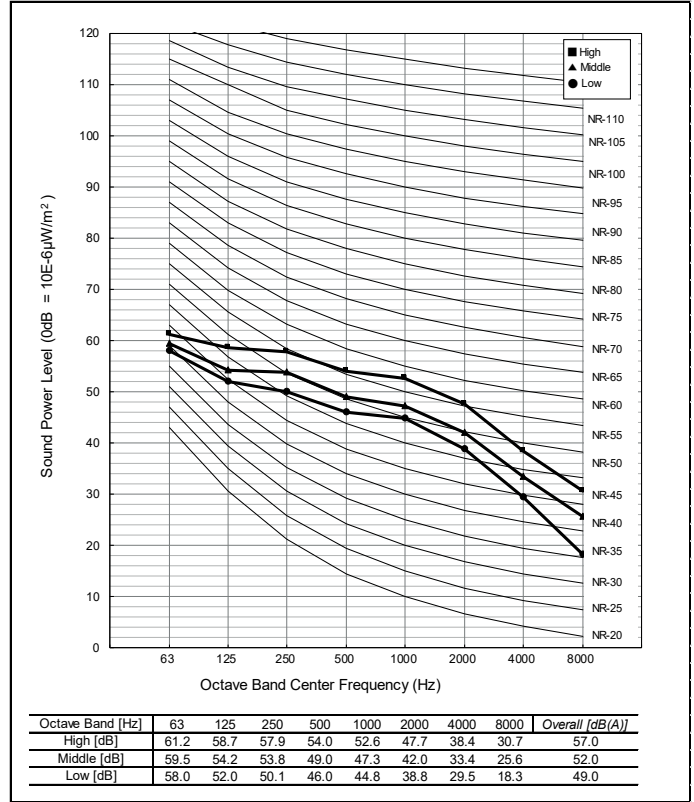


Figure 125: Sound Power Level Diagrams, KNUJB181A, KNUJB241A.

### KNUJB181A



### KNUJB241A



# CONVERTIBLE MID STATIC DUCT INDOOR UNITS <sup>MULTI F</sup> <sup>MULTI F MAX</sup>

## Refrigerant Flow Diagrams

Figure 126: Multi F Convertible Mid Static Ducted Refrigerant Flow Diagram.

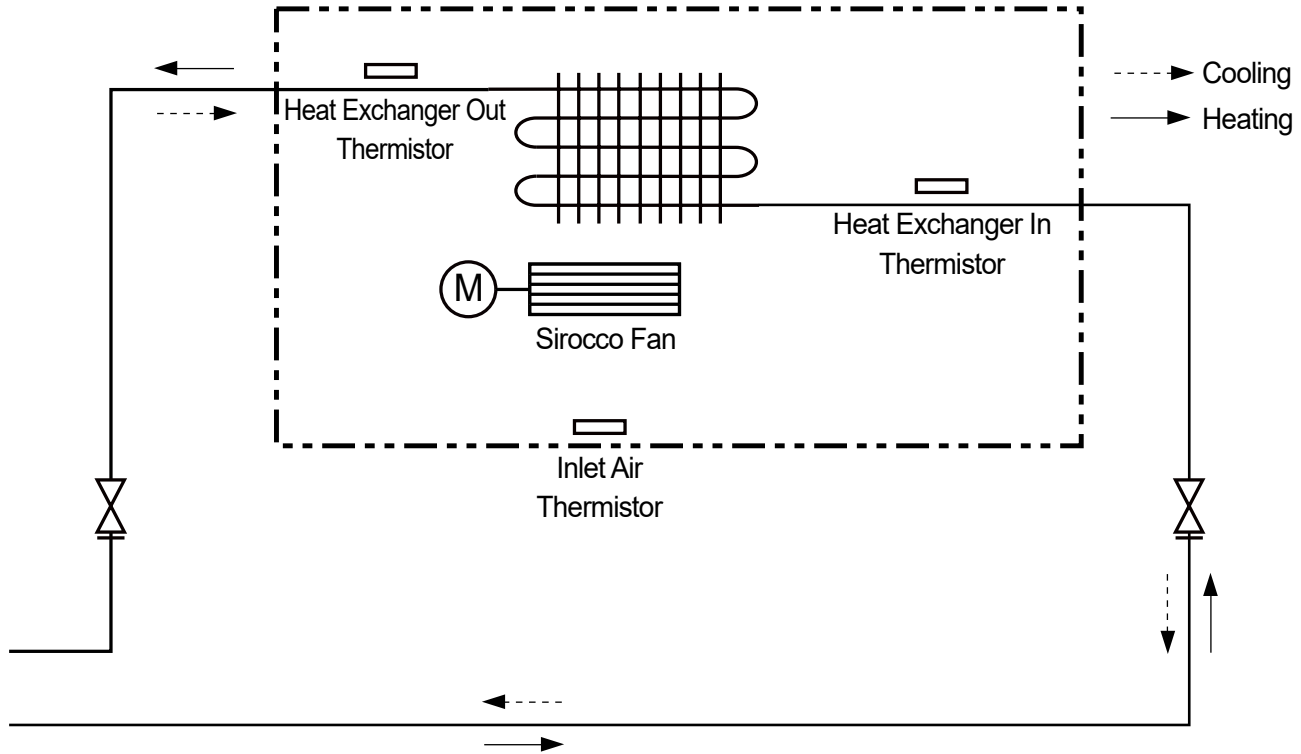


Table 59: Multi F Convertible Mid Static Duct Indoor Units Thermistor Details.

Description (Based on Cooling Mode)	PCB Connector
Indoor Air Temperature Thermistor	CN_ROOM
Evaporator Inlet Temperature Thermistor	CN_PIPE_IN
Evaporator Outlet Temperature Thermistor	CN_PIPE_OUT

Table 60: Multi F Convertible Mid Static Duct Indoor Unit Refrigerant Piping and Connection Sizes.

Model No.	Piping Size		Connection Port Size	
	Liquid (inch)	Vapor (inch)	Liquid (inch)	Vapor (inch)
KNUJB091A	1/4	3/8	1/4	3/8
KNUJB121A	1/4	3/8	1/4	3/8
KNUJB181A	1/4	1/2	1/4	1/2
KNUJB241A*	1/4	1/2	3/8	5/8

\*Refer to Table 61 for KNUJB241A socket connections.

Table 61: KNUJB241A Convertible Mid Static Duct Indoor Unit Refrigerant Pipe Connections.

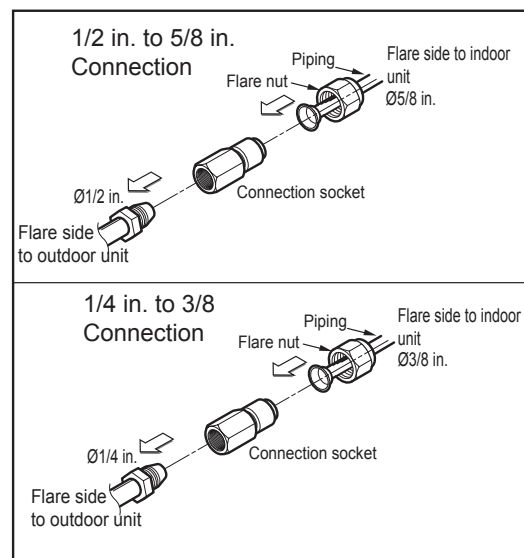
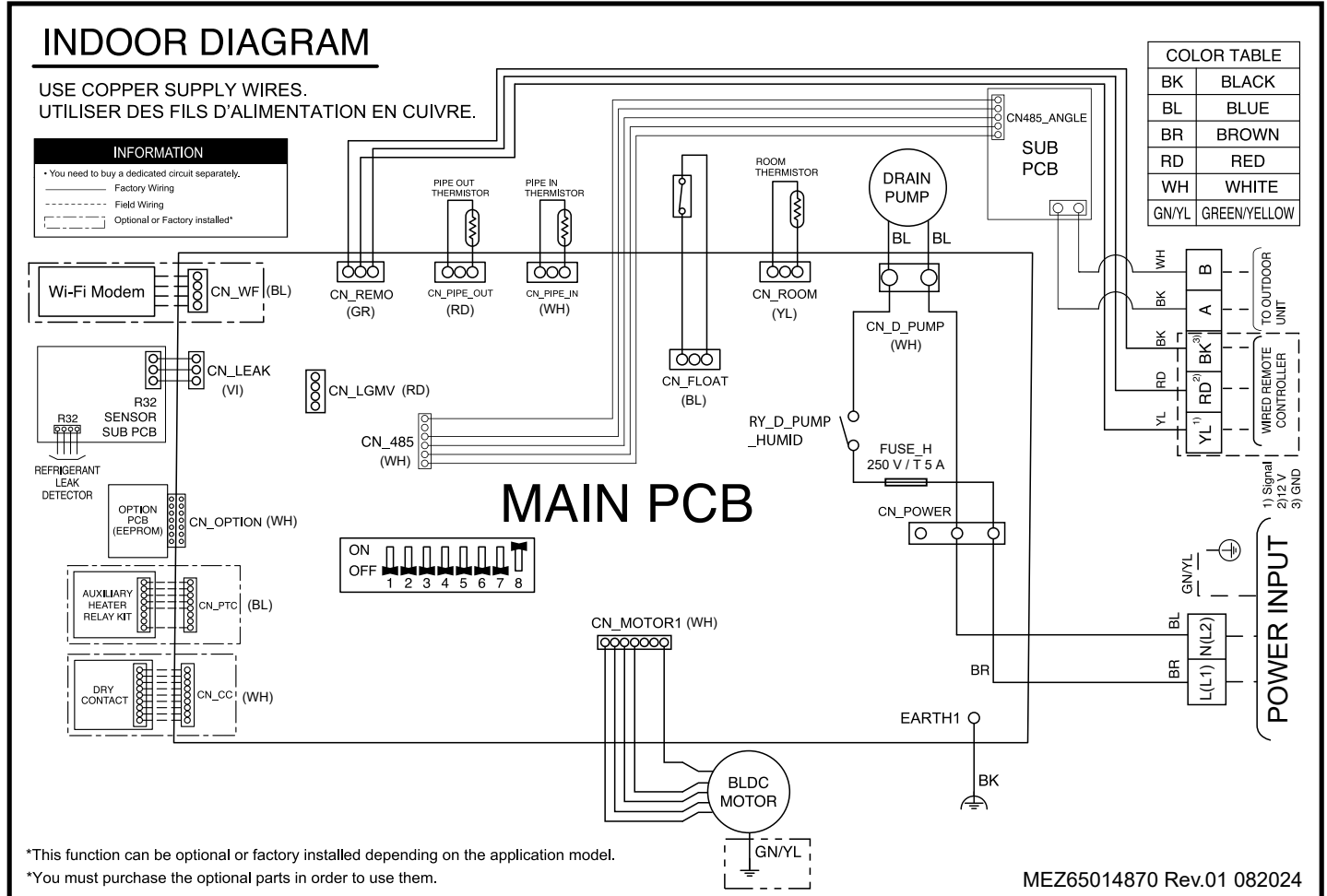


Figure 127: Multi F Convertible Mid Static Duct Indoor Unit Wiring Diagram.



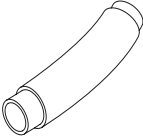

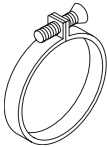
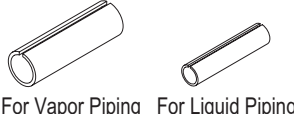
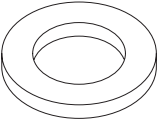
# CONVERTIBLE MID STATIC DUCT INDOOR UNITS <sup>MULTI F</sup> <sup>MULTI F</sup> MAX

Factory Supplied Parts and Materials / Installation

Multi F and Multi F MAX Indoor Unit Engineering Manual

## Factory Supplied Parts

Table 62: Parts Table.

Part	Quantity	Image	Part	Quantity	Image
Drain Hose	One (1)		Zip Ties	Four (4)	
Metal Clamp	Two (2)		Insulation for Fittings	One (1) Set	 For Vapor Piping    For Liquid Piping
Washers for Hanging Brackets	Eight (8)				

## Factory Supplied Materials

- Owner's Manual
- Installation Manual

## Required Tools

- Level
- Screwdriver
- Electric drill
- Hole core drill
- Flaring tool set
- Torque wrenches
- Hexagonal wrench
- Gas-leak detector
- Thermometer

## ⚠ WARNING

Installation work must be performed by trained personnel and in accordance with national wiring standards and all local or other applicable codes. Improper installation can result in fire, electric shock, physical injury, or death.

## NOTICE

Read all instructions before installing this product. Become familiar with the unit's components and connections, and the order of installation. Incorrect installation can degrade or prevent proper operation.

## Selecting the Best Location

### Do's

- Place the unit where air circulation will not be blocked.
- Place the unit where drainage can be obtained easily.
- Place the unit where noise prevention is taken into consideration.
- Ensure there is sufficient strength to bear the load of the indoor unit.
- Ensure there is sufficient maintenance space.
- Locate the indoor unit in a location that is level, and where it can be easily connected to the outdoor unit / branch distribution unit.

### ⊘ Don'ts

- ⊘ Do not install the unit near a heat or steam source, or where considerable amounts of oil, iron powder, or flour are used.
- ⊘ Do not install the unit where sulfuric acid and flammable or corrosive gases are generated, vented into, or stored.
- ⊘ Do not install the unit near high-frequency generators.
- ⊘ Do not install the unit near a doorway.

**The unit will be damaged, will malfunction, and / or will not operate as designed if installed in any of the conditions listed.**

### NOTICE

- ⊗ Indoor units (IDUs) must not be placed in an environment where the IDUs will be exposed to harmful volatile organic compounds (VOCs) or in environments where there is improper air make up or supply or inadequate ventilation. If there are concerns about VOCs in the environment where the IDUs are installed, proper air make up or supply and/or adequate ventilation must be provided. Additionally, in buildings where IDUs will be exposed to VOCs, consider a third party factory-applied epoxy coating to the fan coils for each IDU where the entire coil is dipped, not sprayed.
- If the unit is installed near a body of water, the installation parts are at risk of corroding. Appropriate anti-corrosion methods must be taken for the unit and all installation parts.

### Installing in an Area Exposed to Unconditioned Air

In some installation applications, areas (floors, walls) in some rooms will be exposed to unconditioned air (room will be above or next to an unheated garage or storeroom). To countermeasure:

- Verify that carpet is or will be installed (carpet will increase the temperature by three degrees).
- Add insulation between the floor joists.
- Install radiant heat or another type of heating system to the floor.

### Installing in an Area with High Humidity Levels

If the environment is prone to humidity levels of 80% or more (near the ocean, lakes, etc.) or where steam could collect in the plenum:

- Install additional insulation to the indoor unit (glass wool insulation >13/32 inches thick).
- Install additional insulation to the refrigerant piping (insulation >13/16 inches thick).
- Seal all gaps between the indoor unit and the ceiling tiles (make the area air tight) so that humidity does not transfer from the plenum to the conditioned space. Also, add a ceiling grille for ventilation.

Figure 128: Multi F Convertible Mid Static Duct Indoor Unit Bolt Locations.

Apply a joint-canvas between the unit and duct to absorb unnecessary vibration.

Apply a filter Accessory at air return hole.

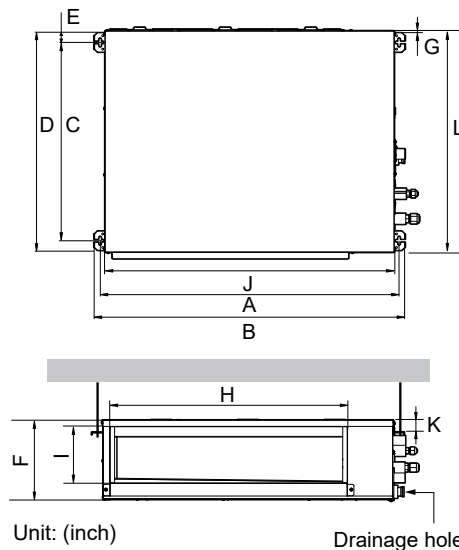
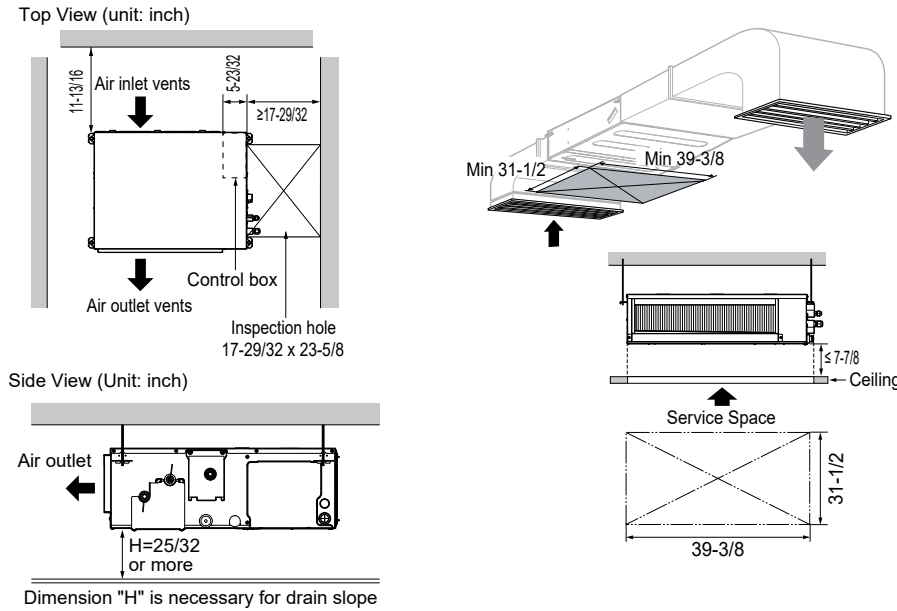


Table 63: Multi F Convertible Mid Static Duct Indoor Unit Bolt Location Dimensions.

Model / Capacity (Btu/h)	Dimensions (inches)											
	A	B	C	D	E	F	G	H	I	J	K	L
KNUJB091A / 9,000	36-3/4	38-9/32	24-3/8	26-3/4	1-3/16	9-21/32	7/32	29-1/16	6-15/16	35-7/16	1-15/32	27-9/16
KNUJB121A / 12,000	36-3/4	38-9/32	24-3/8	26-3/4	1-3/16	9-21/32	7/32	29-1/16	6-15/16	35-7/16	1-15/32	27-9/16
KNUJB181A / 18,000	36-3/4	38-9/32	24-3/8	26-3/4	1-3/16	9-21/32	7/32	29-1/16	6-15/16	35-7/16	1-15/32	27-9/16
KNUJB241A / 24,000	36-3/4	38-9/32	24-3/8	26-3/4	1-3/16	9-21/32	7/32	29-1/16	6-15/16	35-7/16	1-15/32	27-9/16

# CONVERTIBLE MID STATIC DUCT INDOOR UNITS <sup>MULTI F</sup> Installation and Best Layout Practices <sup>MULTI F MAX</sup>

Figure 129: Multi F Convertible Mid Static Duct IDU Access Panel Required Dimensions.



**Note:**

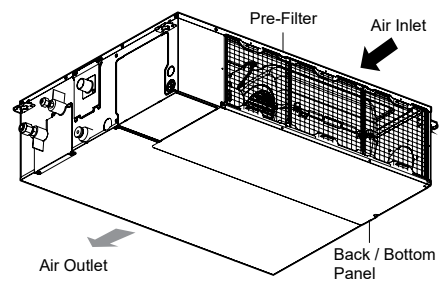
Appearances and installation structure may differ depending on model.  
If the distance between the dropped ceiling and the actual ceiling is <math>< 7-7/8</math> inch, the inspection access area should be greater than the size of indoor unit.

## Changing Air Inlet from Back to Bottom of Indoor Unit

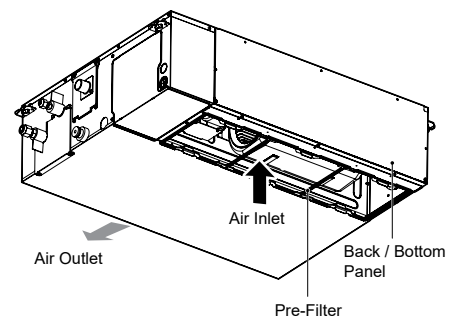
The mid-static ducted indoor unit is factory configured with the air inlet at the back. The unit can be field reconfigured with the inlet from back to bottom in applications where the indoor unit is installed in a recessed ceiling, the return grille is under the indoor unit for a bottom return, and the discharge is horizontal into the room.

Figure 130: Multi F Mid Static Duct Bottom Air Inlet Conversion.

### Factory Configured Back Inlet Position



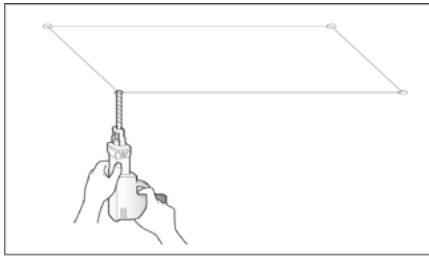
### Field Configured Bottom Inlet Position



### Preparing the Installation Area and Hanging the Indoor Unit Frame for Installation

1. Select and mark the area for the suspension or console bolts (use embedded inserts or anchor bolts in new buildings, and hole-in-anchors in older buildings).
2. Drill the holes.
3. Add the set-anchor and the plate washer to the bolts (bolts must be at least 13/32 inches in diameter), and then insert the bolts into the installation area.
4. Add the plate washer, spring washer, and nut to secure the bolts into the installation area.
5. Position the indoor unit installation plates onto the bolts. Secure using nuts, plate washers, and spring washers. Adjust for level as necessary.

Figure 131: Preparing the Installation Area.



**NOTICE**

Install a canvas duct to the air outlet and air inlet so that vibration from the indoor unit does not carry to the duct or ceiling. Also, add insulation to the interior of the duct, and apply anti-vibration to the suspension bolts.

Figure 132: Suspension Bolt Options.

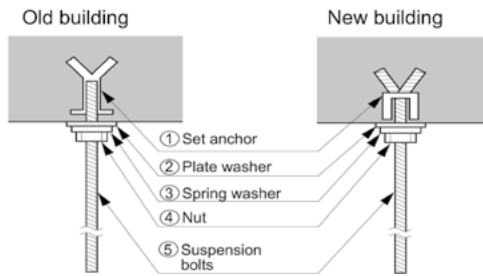
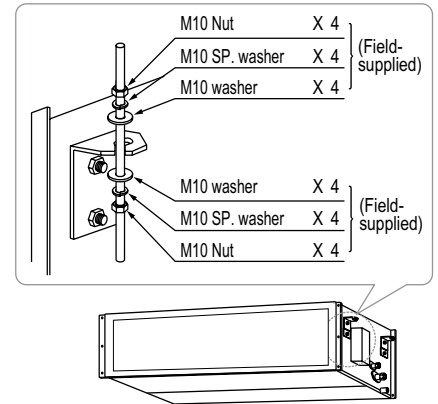


Figure 133: Hanging the Indoor Unit.



**WARNING**

- Unit must be installed correctly. Tighten the nuts and bolts to prevent the unit from falling and causing severe injury or death.

### Installing the Drain System

- Drain piping must have downward gradient of at least 1/50 to 1/100; to prevent reverse flow, slope must not be straight up and down.
- Do not damage the drain port on the indoor unit when connecting the field-supplied drain piping.
- Drain piping specifications:
  - Indoor Unit Drain Connection: 1-1/4 inch outside diameter.
  - Field-Supplied Drain Piping: Polyvinyl chloride piping with 1-inch inside diameter and pipe fittings.

Figure 134: Indoor Unit Drain Piping.

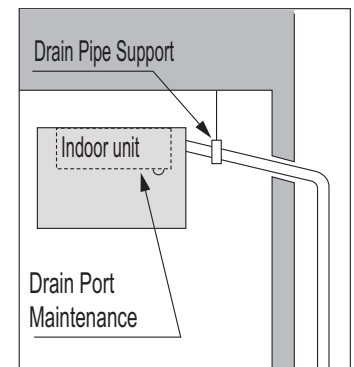
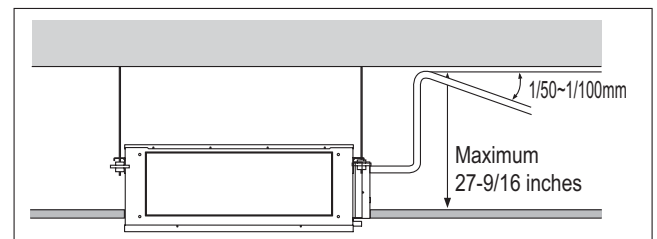
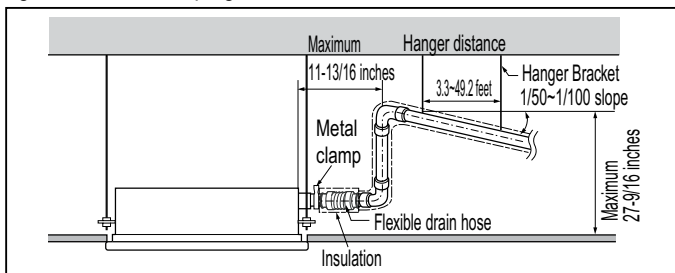


Figure 135: Drain Piping Installation Dimensions.



**NOTICE**

- Do not apply force or twist the drain hose: it will leak.

# CONVERTIBLE MID STATIC DUCT INDOOR UNITS <sup>MULTI F</sup> <sup>MULTI F</sup> MAX

## Installation and Best Layout Practices

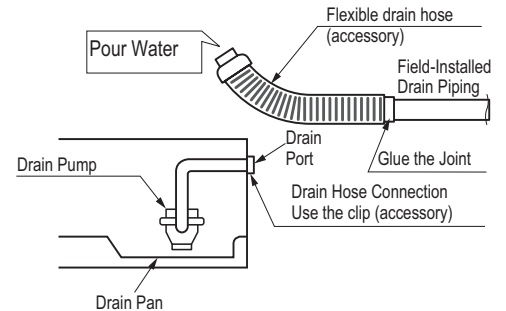
Multi F and Multi F MAX Indoor Unit Engineering Manual

### Checking the Drain Pump

The unit uses a drain pump to remove condensate. The pump must be tested before the system operates.

- Connect (field supplied) flexible drain hose to the field-installed drain piping; leave it as is until the test is complete.
- Pour water into the flexible drain hose and check for leaks.
- After power wiring installation is complete, operate the drain pump to see if it sounds and functions properly.
- After the test is complete, connect the flexible drain hose to the indoor unit drain port.

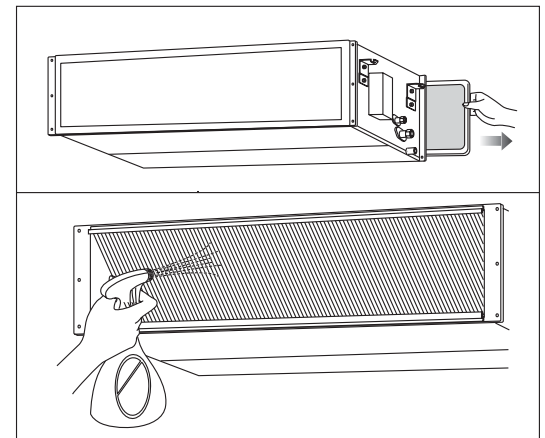
Figure 136: Checking the drain pump.



### Checking the Drainage System

1. Remove the air filter.
2. Check the drainage.
  - Spray water on the evaporator.
  - Verify that water flows through the indoor unit drain hose without leaking.

Figure 137: Checking the Drainage System.



### Insulating the Refrigerant and Drain Piping

#### ⚠ WARNING

Ensure all piping is insulated. Exposed piping can cause burns if touched.

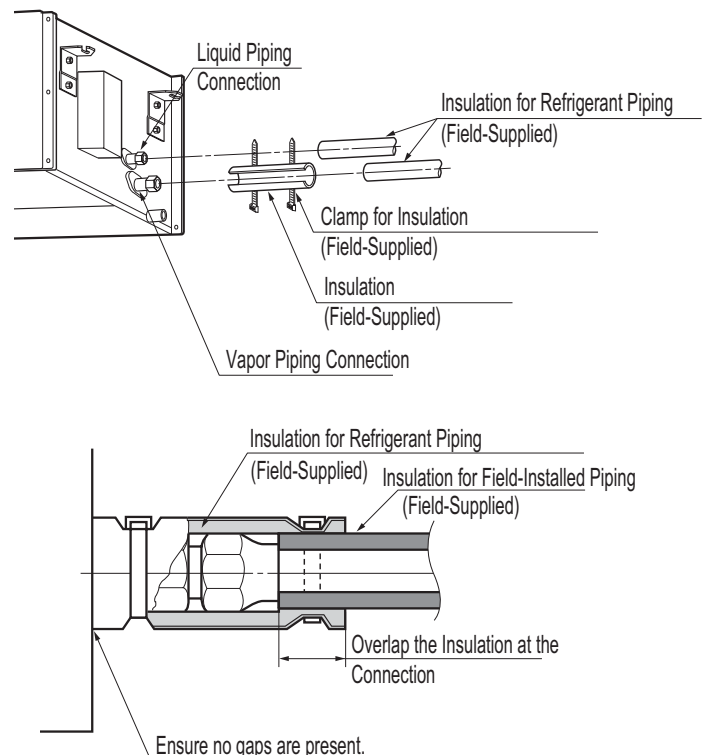
#### Refrigerant Piping Insulation

Field-installed vapor and liquid refrigerant piping lines must be properly and completely covered in insulation (up to the indoor unit piping connections). Any exposed piping will generate condensate or will cause burns if touched. Insulation for this field-installed refrigerant piping must have a minimum heat resistance of 248°F.

#### Drain Piping Insulation

Drain piping must have insulation a minimum of 7/32 inches thick.

Figure 138: Insulating the Piping.



### Convertible Mid Static Duct IDU Vertical Installation

The Mid Static Duct IDU has the option to be installed vertically on a floor or along a wall. The vertical up flow configuration installation requires optional installation kit ABDAMA0 (sold separately) to change the condensate drain pan position suitable for vertical installation.

Figure 139: Convertible Mid Static Duct IDU Vertical Installation Position.

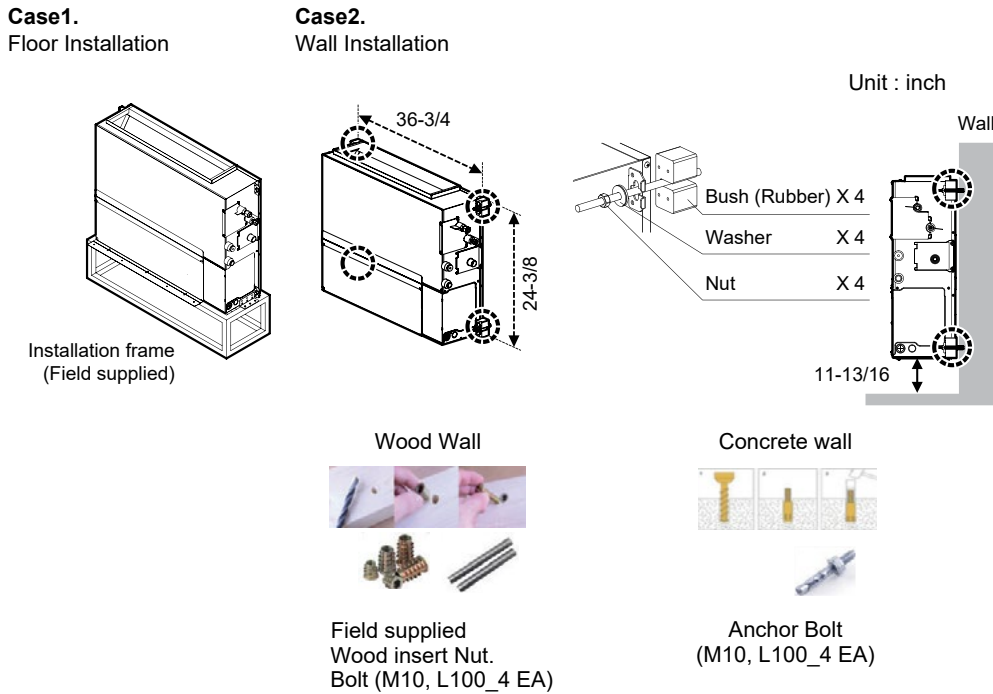
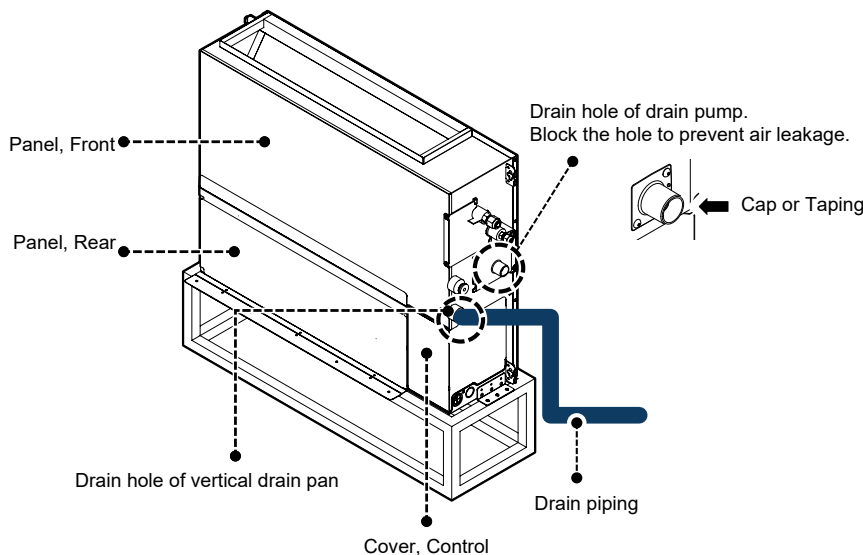


Figure 140: Convertible Mid Static Duct IDU Vertical Installation Drain.

Connect the drain piping to drain hole of vertical drain pan.  
Block the drain hole of drain pump to prevent air leakage.



# CONVERTIBLE MID STATIC DUCT INDOOR UNITS <sup>MULTI F</sup> <sup>MULTI F</sup> MAX

## Installation and Best Layout Practices

### Power Wiring / Communications Cable Guidelines

- Follow manufacturer's circuit diagrams in the technical manuals.
- Confirm power source specifications.
- Confirm that the electrical capacity is sufficient.
- Starting current must be maintained  $\pm 10$  percent of the rated current marked on the outdoor unit name plate.
- Confirm cable thickness specifications.
- It is required that a circuit breaker is installed, especially if conditions could become wet or moist.
- Include a disconnect in the power wiring system, add an air gap contact separation of at least 1/8 inch in each active (phase) conductor.

### **⚠ WARNING**

- Loose wiring will cause unit to malfunction, overheat, and catch fire, resulting in severe injury or death.

### **NOTICE**

- Terminal screws will become loose during transport. Properly tighten the terminal connections during installation.
- A voltage drop will cause the following problems:
  - Magnetic switch vibration, fuse breaks, or disturbance to the normal function of an overload protection device.
  - Compressor will not receive the proper starting current.

### Connecting the Power Wiring and Communications Cable

1. Using a Phillips head screwdriver, remove the metal control box cover (one panel) by unscrewing the two (2) screws that hold it in place. Set aside the metal control box cover and screws for reattachment.
2. Insert the communication / connection (power) cable (from the outdoor unit to the indoor unit) through the designated access hole in the side of the ducted frame (see images). If using a conduit, attach it to the conduit hole, and secure with a lock nut.
3. Attach the communication / connection (power) cable to the inside of the frame with the clamp.
4. Using a JIS screwdriver, connect the cable terminals to the terminal block. Ensure wire color and terminal number of the indoor unit matches those of the outdoor unit. Refer to the wiring diagram on the indoor unit.
5. When installing the wired remote controller (sold separately), insert the controller wiring through its designated access hole below the communication / connection (power) cable. Refer to the wiring diagram on the indoor unit. Using a JIS screwdriver, attached that cable to the appropriate terminal block connection.
6. Reinstall the metal control box by reattaching it with its two (2) screws.

Figure 141: Removing the Control Box Cover.

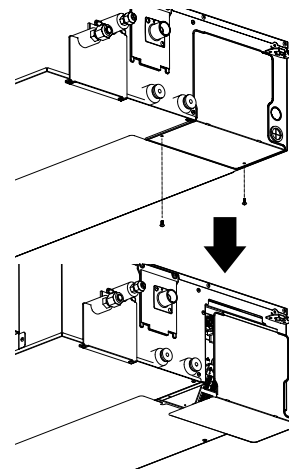


Figure 142: Access Holes Location.

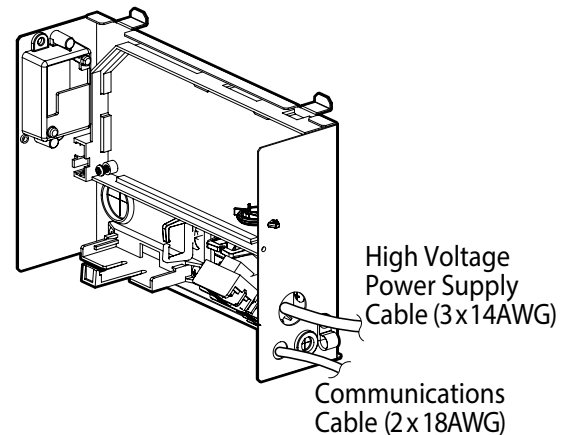
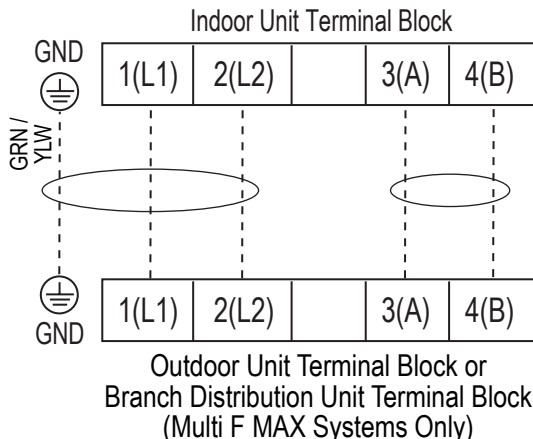


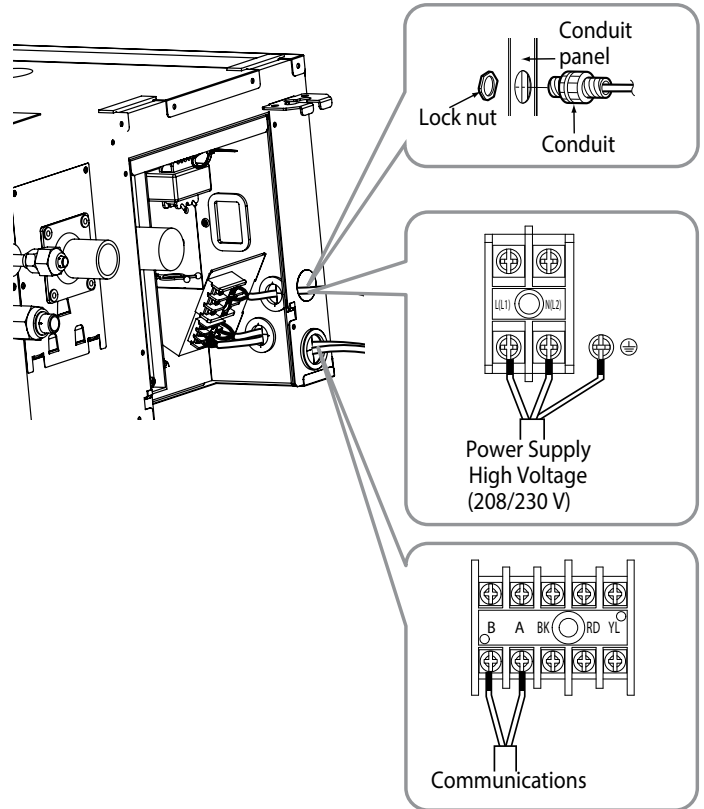
Figure 143: Simplified View of Indoor Unit to Outdoor Unit / Branch Distribution Unit Terminal Connections.



### NOTICE

- Each wire must be securely attached to the terminal block.
- Ground cable must be longer than the other wires.
- Secure the cable onto the control board using a cable tie.
- Use a conduit to protect the cable / refrigerant piping from the indoor unit to the outdoor unit.

Figure 144: Using a Conduit.



## Controller Options

Convertible Mid Static Duct indoor units can be used with many LG-supplied wired controllers (sold separately). The wireless handheld controller (Model No. PWLSSB21H) is also an optional accessory with use of the wired controller.

### Wired Controller Connections

Controllers can connect to the indoor unit in one of two different ways.

1. LG Wired Remote Extension Cable with Molex plug (PZCWRC1; sold separately) that connects to the CN-REMO terminal on the indoor unit PCB.
2. Field-supplied controller cable that connects to the indoor unit terminal block (must be at least UL2547 or UL1007, 22 AWG, two-core, one-shield core, at least FT-6 rated if local electric and building codes require plenum cable usage).

### NOTICE

When using field-supplied controller cable, make sure to connect the yellow to yellow (communications wire), red to red (12V power wire), and black to black (ground wire) terminals from the remote controller to the indoor unit terminal blocks.

Figure 145: PZCWRC1 LG Wired Remote Extension Cable.

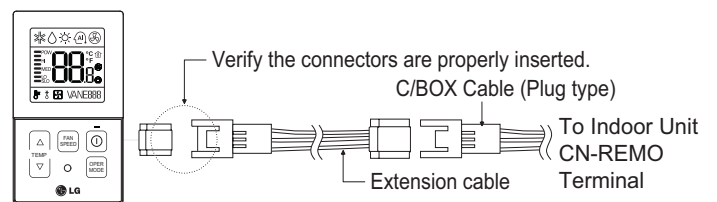
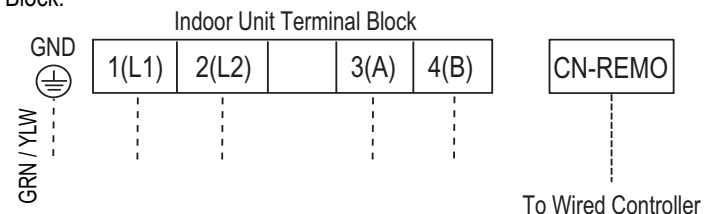


Figure 146: Wired Controller Connections on the Indoor Unit Terminal Block.



# CONVERTIBLE MID STATIC DUCT INDOOR UNITS <sup>MULTI F</sup> <sup>MULTI F MAX</sup>

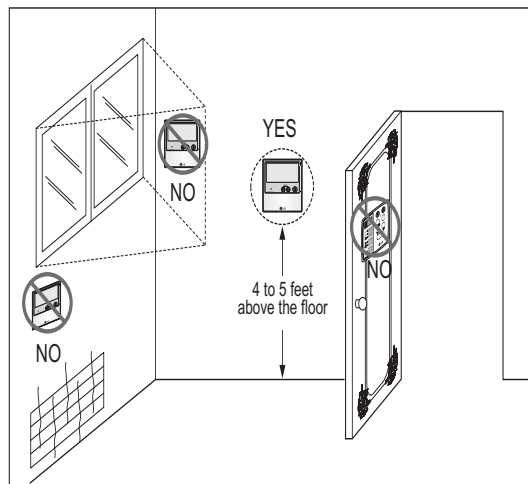
## Installation and Best Layout Practices

### Wired Controller Placement

Wired controllers include a sensor to detect room temperature. To maintain comfort levels in the conditioned space, the wired controller must be installed in a location away from direct sunlight, high humidity, and where it could be directly exposed to cold air. Controller must be installed four (4) to five (5) feet above the floor where its LED display can be read easily, in an area with good air circulation, and where it can detect an average room temperature.

- ⊘ Do not install the wired controller near or in:
  - Drafts or dead spots behind doors and in corners
  - Hot or cold air from ducts
  - Radiant heat from the sun or appliances
  - Concealed pipes and chimneys
  - An area where temperatures are uncontrolled, such as an outside wall

Figure 147: Proper Location for the Wired Controller.



### Hanging the Wired Controller

1. The controller wiring / cable can be installed in one of three directions: top, back, or on the right side. If top or right side installation is desired, remove cable guide grooves on the controller, and then position wiring / cable on applicable side.
2. Choose and mark the area of installation, and then screw the wall plate into place (using the provided parts). Install the controller wall plate to fit the electrical box if one is present. Ensure that no gaps exist between the wall plate and the wall itself.
3. Arrange wiring / cables so as not to interfere with the controller circuitry. Position the wired controller on the wall plate. Snap into place by pressing the bottom part of the wired controller onto the wall plate. Make sure that no gaps exist between the wired controller and the wall plate on all sides.
4. To remove wired controller from the wall plate, insert a screwdriver into the two holes at the bottom. Twist screwdriver to release controller. ⊘ Do not damage the controller components when removing.

Figure 148: Removing the Cable Guide Grooves.

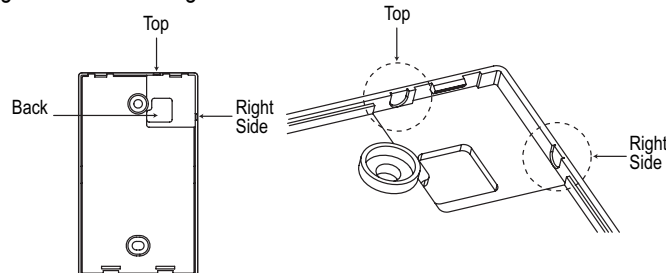


Figure 149: Attaching the Wall Plate.

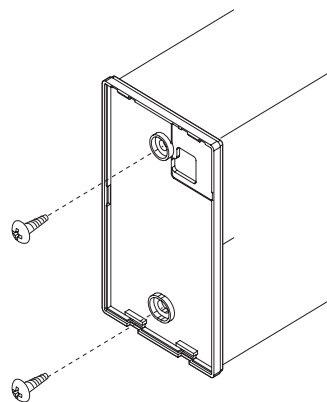
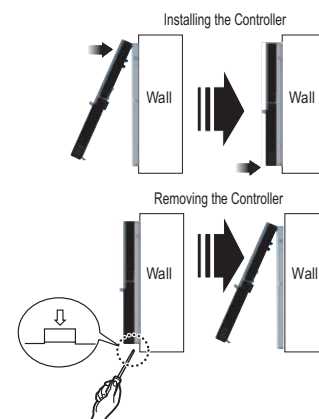


Figure 150: Installing / Removing the Controller.



### Assigning the Thermistor for Temperature Detection

Each indoor unit includes a return air thermistor assigned to sense the temperature. If a wired controller is installed, there is a choice of sensing temperature with either the indoor unit return air thermistor or the thermistor in the wired controller. It is also an option to set both thermistors to sense temperature so that indoor unit bases its operation on the first thermistor to reach the designated temperature differential. For applicable indoor units, an optional Remote Temperature Sensor can be used in lieu of the return air thermistor—either alone or in conjunction with a wired controller thermistor as previously described.

### External Static Pressure Control

To provide a required air flow rate that accounts for the external static pressure change, follow the steps below.

1. To access system installer setting mode, press and hold the temperature increase and mode selection buttons simultaneously for approximately three (3) seconds. Choose setting code value "06" by pressing the mode selection button.
2. Use the temperature increase and decrease buttons to select the desired setting value.

#### Setting Values

- 01 : V-H
- 02 : F-H
- 03 : V-L
- 04 : F-L

3. Press the on / off button to save the established settings.
4. To deactivate system installer setting mode after the settings have been established, press and hold the temperature increase and mode selection check buttons simultaneously for approximately three (3) seconds. If a button is not pressed for more than 25 seconds, the system installer setting mode will automatically deactivate.

Figure 151: Select Code and Set Value.

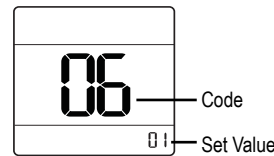


Figure 152: Controller External Static Pressure Setting Display.

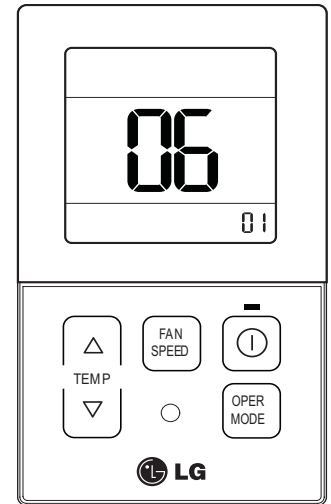


Table 64: Static Pressure Setting Table.

Pressure Selection		Function	
		Zone State	External Static Pressure Standard Value
01	V-H	Variable	High
02	F-H	Fixed	High
03	V-L	Variable	Low
04	F-L	Fixed	Low

#### NOTICE

- Select the position after verifying duct work and the external static pressure of the indoor unit.
- Factory set to pressure selection F-H.

# CONVERTIBLE MID STATIC DUCT INDOOR UNITS <sup>MULTI F</sup> <sup>MULTI F MAX</sup>

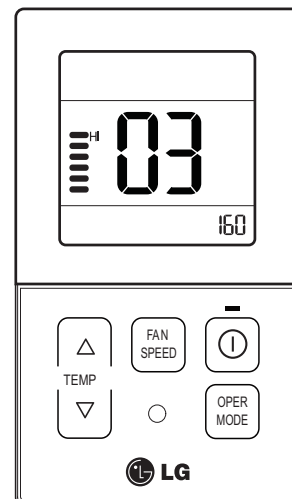
## Installation and Best Layout Practices

### Assigning Air Flow

To assign an air flow for each fan speed, follow the steps below.

1. To access system installer setting mode, press and hold the temperature increase and mode selection buttons simultaneously for approximately three (3) seconds. Choose setting code value "03" by pressing the mode selection button.
2. Use the fan speed button to select the desired fan speed. ( Lo→Med→Hi will display on the LED).
3. Use the temperature increase and decrease buttons to select the desired external static pressure setting value (thereby assigning the respective airflow). External static pressure value range: 0~255; the value will display near the lower right corner of the LED.
4. Press the on / off button to save the established settings.
5. To deactivate system installer setting mode after the settings have been established, press and hold the temperature increase and mode selection check buttons simultaneously for approximately three (3) seconds. If a button is not pressed for more than 25 seconds, the system installer setting mode will automatically deactivate.

Figure 153: Controller External Static Pressure Setting Display.



### NOTICE

- A trained technician must set the external static pressure value(s). If the external static pressure is set incorrectly, the system will malfunction.
- Do not alter the external static pressure value that corresponds to each air flow level.
- External static pressure value can vary depending on the indoor unit.
- If by pressing the fan speed button during external static pressure setup, the fan speed is raised to the next level, the air flow value of the previous fan speed will be maintained (external static pressure setting value is saved).

# MID STATIC DUCT INDOOR UNIT DATA

**Mechanical Specifications on page 124**

**General Data / Specifications on page 125**

**Dimensions on page 126**

**Cooling Capacity Table on page 127**

**Heating Capacity Table on page 128**

**External Static Pressure / Acoustic Data on page 129**

**Refrigerant Flow Diagrams on page 131**

**Wiring Diagram on page 132**

**Factory Supplied Parts and Materials on page 133**

**Installation and Best Layout Practices on page 134**

# MID STATIC DUCT INDOOR UNITS

## Mechanical Specifications and Features

MULTI F  
MULTI F MAX

### Mid Static Duct Indoor Unit

#### General

All LG indoor units are factory assembled, wired, piped, and provided with a control circuit board, fan, and motor. Mid Static Duct units are designed for high-speed air volume against an external static pressure up to 0.59"WG.

#### Coil

Indoor unit coils are factory built and are comprised of aluminum fins mechanically bonded to copper tubing. Each unit has three rows of coils, which are pressure tested at the factory. Each unit is provided with a factory installed condensate drain pan below the coil.

#### Refrigerant System

System is designed for use with R32 refrigerant. The refrigeration circuit is pressure-tested at the factory and shipped with a holding charge of helium gas. Refrigerant pipe connections are 45° flare, and all refrigerant lines from the outdoor unit to the indoor units must be field insulated.

#### Electrical

Each indoor unit is designed to operate using 208–230/60/1 power with voltage variances of ±10%.

#### Casing

The casing is designed to mount fully concealed above a finished ceiling. Casing is manufactured of galvanized steel plate. Cold surfaces of the unit are covered internally with a coated polystyrene insulating material, and covered externally with sheet insulation made of ethylene propylene diene monomer (M-Class) (EPDM). External insulation is plenum rated and conforms to ASTM Standard D-1418. Hanger brackets are included on the casing to support the weight on four corners. Unit has a front horizontal supply air discharge outlet, and one dedicated rear horizontal return air inlet.

#### Fan Assembly and Control

The indoor unit has two direct-drive Sirocco fans. The fans are made of high strength ABS GP-2200 polymeric resin that are statically and dynamically balanced. The fans are mounted on a common brushless digitally controlled (BLDC) motor with permanently lubricated and sealed ball bearings. The fan / motor assembly is mounted on vibration-attenuating rubber grommets. Fan speed is controlled using a microprocessor-based direct digital control algorithm. The indoor fan has Low, Med, High, and Auto settings for Cooling mode; and has Low, Med, High, and Auto settings for Heating mode. Each of the settings can be field-adjusted from the factory setting (RPM / ESP). The Auto setting adjusts the fan speed based on the difference between the controller setpoint and space temperature.

#### Air Filter

### Features

- Inverter (Variable speed fan)
- Internal drain pump
- Control lock function
- Auto operation
- Auto restart operation
- Dehumidifying function
- Two thermistor control
- External static pressure control
- Group control
- Self-diagnostics function
- Wired controller ordered separately
- Wi-Fi compatible

Figure 154: Multi F Mid Static Duct Indoor Unit.



Return air is filtered with a factory-supplied, removable, washable filter accessible from the rear of the indoor unit. High efficiency air filter options include a return filter box that holds a field-provided high efficiency one or two inch MERV-rated filter.

#### Microprocessor Control

The unit is provided with an integrated control panel to communicate with the outdoor unit. All unit operation parameters are stored in non-volatile memory resident on the unit microprocessor. The microprocessor controls space temperature through using the value provided by the temperature sensor within the indoor unit. The microprocessor control will activate indoor unit operation when the indoor room temperature falls below or rises above a setpoint temperature, at which point, a signal is sent to the outdoor unit to begin the appropriate mode. The microprocessor will also provide self-diagnostics and auto restart functions. A field-supplied three-wire power cable (3 x 14 AWG) and two-wire communications cable (2 x 18 AWG) must be installed to connect the indoor unit(s) to the outdoor unit.

#### R32 Refrigerant Leak Detector

The indoor unit has a built-in R32 refrigerant leak detection sensor designed to communicate with release mitigation devices and third party alarms, and transmit a system error code upon detection of a refrigerant leak or sensor failure / expiration.

#### Shut-off Valve

LG single-port shutoff valve (PRHPZ010A; sold separately) is available as an accessory.

#### Controls

The indoor unit controller of choice must be ordered separately. Communication between the indoor units and the outdoor unit is accomplished through 18 AWG, two-core, stranded and shielded communication cable.

#### Condensate Lift/Pump

The indoor unit is provided with a factory installed and wired internal condensate lift/pump capable of providing a minimum 27.5 inch lift from the bottom surface of the unit. Drain pump has a safety switch to shut off the indoor unit if the condensate rises too high in the drain pan.

Table 65: Multi F Mid Static Duct Indoor Unit General Data.

Model Name	KNUJB301A	KNUJB361A
Nominal Cooling Capacity (Btu/h) <sup>1</sup>	30,000	36,000
Nominal Heating Capacity (Btu/h) <sup>1</sup>	34,000	40,000
<i>Operating Range</i>		
Cooling (°F WB)	57-77	57-77
Heating (°F DB)	59-81	59-81
<i>Fan</i>		
Type	Sirocco	Sirocco
Motor Output (W) x Qty.	350 x 1	350 x 1
Motor/Drive	Brushless Digitally Controlled / Direct	Brushless Digitally Controlled / Direct
Factory Set Airflow Rate CFM (H/M/L)	989 / 848 / 741	1,130 / 989 / 848
Factory Set External Static Pressure (in. wg)	0.24	0.24
Maximum External Static Pressure (in. wg)	0.59	0.59
<i>Unit Data</i>		
Refrigerant Type <sup>2</sup>	R32	R32
Refrigerant Control	EEV	EEV
Power Supply V, Ø, Hz <sup>3</sup>	208-230, 1, 60	208-230, 1, 60
Rated Amps (A)	2.3	2.3
Sound Pressure Level (Standard Mode) dB(A) H/M/L <sup>4</sup>	34 / 33 / 32	36 / 34 / 33
Dimensions (W x H x D, in.)	49-7/32 x 10-5/8 x 27-9/16	49-7/32 x 10-5/8 x 27-9/16
Net Unit Weight (lbs.)	85.3	85.3
Shipping Weight (lbs.)	98.3	98.3
Power Wiring Cable (No. x AWG) <sup>5</sup>	3 x 14	3 x 14
Communications Wiring Cable (No. x AWG) <sup>5</sup>	2 x 18	2 x 18
Heat Exchanger (Row x Column x Fin / inch) x Number	(3 x 13 x 18) x 1	(3 x 13 x 18) x 1
Dehumidification Rate (pts./hr)	5.6	7.17
<i>Pipe Size</i>		
Liquid (in.)	3/8	3/8
Vapor (in.)	5/8	5/8
<i>Connection Size</i>		
Liquid (in.)	3/8	3/8
Vapor (in.)	5/8	5/8
Drain O.D. / I.D. (in.)	1-1/4, 1	1-1/4, 1

<sup>1</sup>Nominal capacity is rated 0 ft. above sea level with corresponding refrigerant piping length in accordance with standard length of each outdoor unit and a 0 ft. level difference between outdoor and indoor units. All capacities are net with a combination ratio between 95 – 105%.

Nominal cooling capacity rating obtained with air entering the indoor unit at 80°F dry bulb (DB) and 67°F wet bulb (WB) and outdoor ambient conditions of 95°F dry bulb (DB) and 75°F wet bulb (WB).  
Nominal heating capacity rating obtained with air entering the indoor unit at 70°F dry bulb (DB) and 60°F wet bulb (WB) and outdoor ambient conditions of 47°F dry bulb (DB) and 43°F wet bulb (WB).

<sup>2</sup>This unit comes with a dry helium charge.

<sup>3</sup>Acceptable operating voltage: 187V-253V.

<sup>4</sup>Sound pressure levels are tested in an anechoic chamber under ISO Standard 3745 and are the same in both cooling and heating mode. These values can increase due to ambient conditions during operation.

<sup>5</sup>The power wiring and the communication wiring from the outdoor unit to the indoor unit, or from the branch distribution unit to the indoor unit is field supplied and must be stranded, shielded or unshielded (if shielded, it must be grounded to the chassis of the outdoor unit only). All wiring must comply with applicable local and national codes.

# MID STATIC DUCT INDOOR UNITS

## Dimensions

MULTI F  
MULTI F MAX

Figure 155: KNUJB301A and KNUJB361A Dimensions.

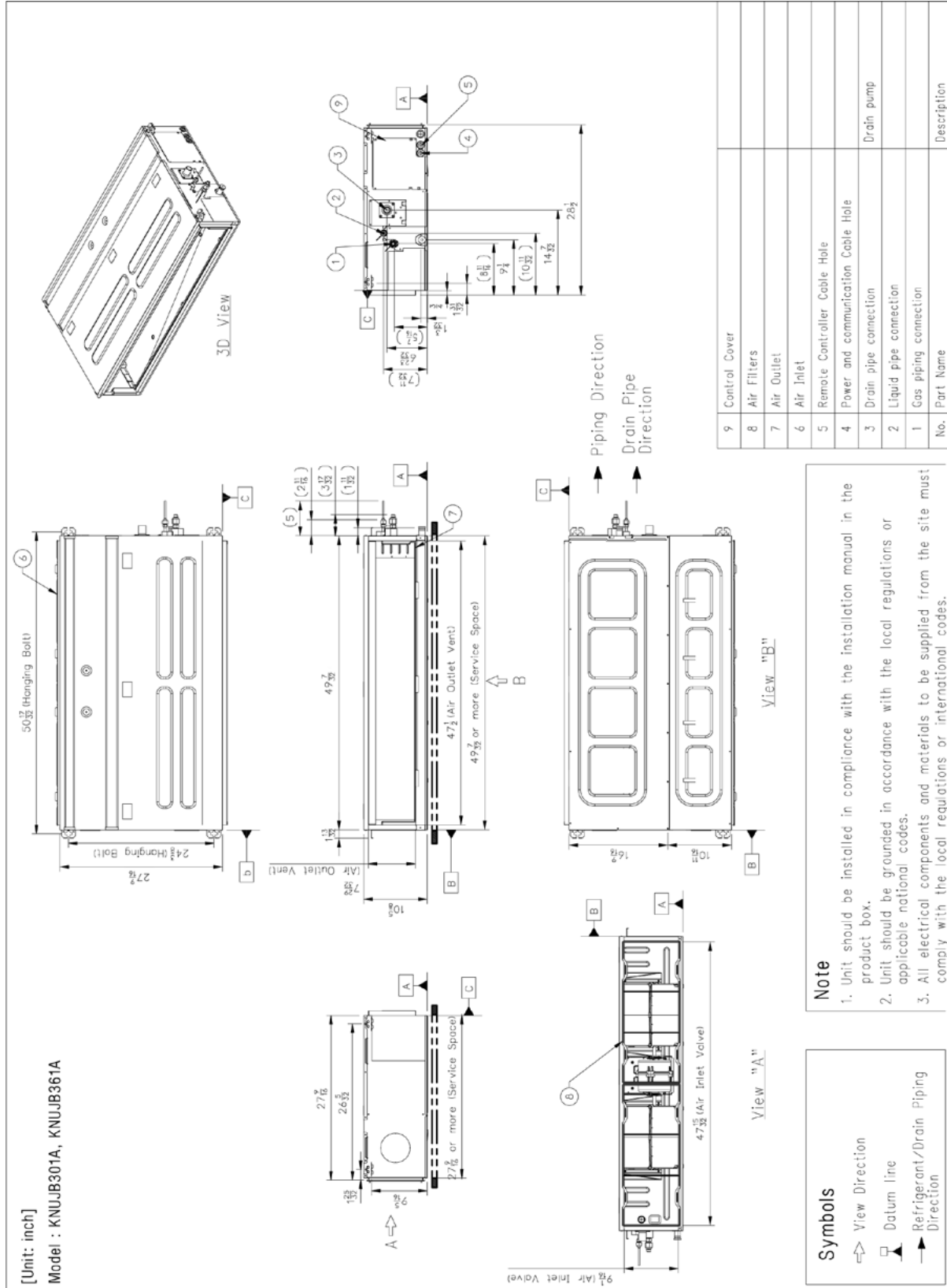


Table 66: Multi F Mid Static Duct Indoor Units Cooling Capacity Table.

Model No. / Nominal Capacity of Indoor Unit (Btu/h)	Outdoor Air Temp. (°F DB)	Indoor Air Temp. °F DB / °F WB											
		68 / 57		73 / 61		77 / 64		80 / 67		86 / 72		90 / 75	
		TC	SHC	TC	SHC	TC	SHC	TC	SHC	TC	SHC	TC	SHC
KNUJB301A 30,000	14	29.50	20.87	31.33	22.03	33.15	21.33	34.48	21.78	36.82	21.97	38.65	22.38
	20	29.48	20.98	31.32	22.17	33.13	21.47	34.47	21.92	36.80	22.10	38.63	22.52
	25	29.45	21.17	31.28	22.37	33.12	21.65	34.43	22.10	36.77	22.30	38.60	22.72
	30	29.43	21.33	31.27	22.53	33.08	21.82	34.40	22.28	36.75	22.47	38.57	22.90
	35	29.42	21.50	31.23	22.72	33.07	22.00	34.38	22.45	36.72	22.65	38.53	23.08
	40	29.38	21.67	31.22	22.90	33.03	22.17	34.35	22.63	36.68	22.82	38.52	23.25
	45	29.37	21.83	31.18	23.07	33.02	22.33	34.33	22.82	36.67	23.00	38.48	23.43
	50	29.33	22.00	31.17	23.25	32.98	22.52	34.30	22.98	36.63	23.18	38.45	23.62
	55	29.32	22.17	31.13	23.42	32.97	22.68	34.28	23.17	36.60	23.35	38.42	23.80
	60	29.30	22.35	31.12	23.60	32.93	22.85	34.25	23.33	36.57	23.53	38.40	23.98
	65	29.27	22.52	31.10	23.78	32.92	23.02	34.22	23.50	36.55	23.70	38.37	24.15
	70	29.25	22.67	31.07	23.95	32.88	23.20	34.20	23.68	36.52	23.88	38.33	24.33
	75	29.23	22.83	31.05	24.13	32.87	23.37	34.17	23.85	36.48	24.05	38.30	24.52
	80	29.20	23.00	31.02	24.30	32.83	23.53	34.15	24.03	36.47	24.23	38.28	24.68
	85	29.18	23.17	31.00	24.48	32.82	23.70	34.12	24.20	36.43	24.40	38.25	24.87
	90	29.17	23.33	30.97	24.65	32.78	23.87	34.10	24.37	36.40	24.58	38.22	25.05
	95	28.47	22.95	30.27	24.28	32.07	23.53	<b>33.38</b>	<b>24.05</b>	35.68	24.28	37.50	24.77
	100	27.77	22.57	29.57	23.90	31.37	23.18	32.67	23.72	34.97	23.97	36.77	24.47
105	27.07	22.15	28.87	23.50	30.67	22.83	31.95	23.37	34.25	23.65	36.05	24.17	
110	26.37	21.73	28.17	23.08	29.95	22.47	31.25	23.00	33.53	23.32	35.33	23.85	
115	25.62	21.50	27.40	22.88	29.18	22.28	30.00	22.50	32.75	23.20	34.53	23.73	
118	24.98	20.93	26.77	22.30	28.55	21.75	29.62	22.15	32.13	22.70	33.92	23.25	
122	24.37	20.35	26.15	21.72	27.93	21.23	29.22	21.80	31.50	22.20	33.28	22.77	
KNUJB361A 36,000	14	23.73	19.65	25.53	21.02	27.32	20.57	28.60	21.15	30.88	21.57	32.67	22.15
	20	23.12	19.07	24.90	20.43	26.68	20.03	27.98	20.62	30.25	21.05	32.03	21.63
	25	22.75	18.93	24.53	20.30	26.32	19.92	27.60	20.52	29.88	20.98	31.67	21.58
	30	22.62	18.88	24.40	20.27	26.18	19.88	27.48	20.48	29.75	20.95	31.53	21.57
	35	35.18	26.97	37.36	28.50	39.56	27.60	41.14	28.19	43.92	28.41	46.10	28.96
	40	35.16	27.20	37.34	28.72	39.52	27.81	41.10	28.39	43.88	28.64	46.08	29.19
	45	35.12	27.40	37.32	28.94	39.50	28.01	41.06	28.60	43.86	28.84	46.04	29.39
	50	35.10	27.58	37.28	29.14	39.46	28.23	41.04	28.82	43.82	29.06	46.00	29.61
	55	35.08	27.79	37.26	29.37	39.44	28.43	41.00	29.02	43.78	29.27	45.96	29.83
	60	35.04	27.99	37.22	29.57	39.40	28.64	40.98	29.25	43.76	29.49	45.94	30.04
	65	35.02	28.19	37.20	29.79	39.38	28.84	40.94	29.45	43.72	29.69	45.90	30.26
	70	35.00	28.39	37.16	30.00	39.34	29.04	40.92	29.65	43.68	29.92	45.86	30.48
	75	34.16	27.93	36.32	29.55	38.48	28.64	40.06	29.27	42.82	29.55	45.00	30.14
	80	33.32	27.46	35.48	29.08	37.64	28.21	39.20	28.86	41.96	29.16	44.12	29.77
	85	32.48	26.95	34.64	28.60	36.80	27.79	38.34	28.43	41.10	28.78	43.26	29.41
	90	31.64	26.45	33.80	28.09	35.94	27.34	37.50	27.99	40.24	28.37	42.40	29.02
	95	30.74	26.16	32.88	27.85	35.02	27.12	<b>36.00</b>	<b>27.38</b>	39.30	28.23	41.44	28.88
	100	29.98	25.47	32.12	27.14	34.26	26.47	35.54	26.95	38.56	27.62	40.70	28.29
105	29.24	24.76	31.38	26.43	33.52	25.84	35.06	26.53	37.80	27.01	39.94	27.70	
110	28.48	23.91	30.64	25.57	32.78	25.03	34.32	25.74	37.06	26.24	39.20	26.95	
115	27.74	23.20	29.88	24.87	32.02	24.38	33.58	25.09	36.30	25.62	38.44	26.33	
118	27.30	23.04	29.44	24.70	31.58	24.24	33.12	24.97	35.86	25.53	38.00	26.26	
122	27.14	22.98	29.28	24.66	31.42	24.20	32.98	24.93	35.70	25.49	37.84	26.24	

Mid Static Duct

TC = Total Capacity (kBtu/h).

SHC: Sensible Heat Capacity (kBtu/h).

Nominal capacity as rated 0 ft. above sea level and a 0 ft. level difference between outdoor and indoor units. Corresponding refrigerant piping length is accordance with standard length of each outdoor unit.

Nominal cooling capacity rating obtained with air entering the indoor unit at 80°F dry bulb (DB) and 67°F wet bulb (WB), and outdoor ambient conditions of 95°F dry bulb (DB) and 75°F wet bulb (WB).

The shaded table columns and rows indicate reference data. When operating at this temperature, these values can be different if the system is not running consistently.

# MID STATIC DUCT INDOOR UNITS

## Heating Capacity Table

**MULTI F**  
**MULTI F MAX**

Table 67: Multi F Mid Static Duct Indoor Units Heating Capacity Table.

Model No. / Nominal Capacity of Indoor Unit (Btu/h)	Outdoor Air Temp.		Indoor Air Temp. °F DB					
	°F DB	°F WB	61	64	68	70	72	75
			TC	TC	TC	TC	TC	TC
KNUJB301A 30,000	0	-0.4	18.9	18.5	18.0	17.7	17.4	16.8
	5	4.5	20.3	19.8	19.3	18.9	18.7	18.0
	10	9	22.1	21.7	21.0	20.7	20.4	19.7
	17	15	24.6	24.1	23.4	<b>23.0</b>	22.7	21.9
	20	19	25.8	25.2	24.5	24.1	23.8	22.9
	25	23	27.8	27.1	26.4	25.9	25.6	24.7
	30	28	29.7	29.1	28.2	27.8	27.4	26.4
	35	32	31.7	31.0	30.1	29.6	29.2	28.1
	40	36	33.7	32.9	32.0	31.4	31.0	29.9
	45	41	35.6	34.8	33.8	33.3	32.8	31.6
	47	43	36.4	35.6	34.6	<b>34.00</b>	33.6	32.3
	50	46	36.5	35.8	34.9	34.4	34.0	32.8
	55	51	36.7	36.1	35.4	35.0	34.7	33.7
	60	56	36.9	36.4	35.9	35.6	35.4	34.5
	63	59	37.0	36.6	36.2	36.0	35.8	35.0
68	64	37.1	36.8	36.6	36.4	36.2	35.5	
KNUJB361A 36,000	0	-0.4	22.1	20.9	20.5	20.2	20.0	19.1
	5	4.5	24.9	23.7	23.2	22.8	22.5	21.6
	10	9	26.7	25.7	24.9	24.5	24.2	23.2
	17	15	28.8	27.8	26.9	<b>26.4</b>	26.0	25.0
	20	19	30.2	29.2	28.3	27.8	27.4	26.3
	25	23	32.5	31.5	30.6	30.0	29.6	28.5
	30	28	34.9	33.9	32.9	32.3	31.8	30.7
	35	32	37.2	36.2	35.2	34.6	34.1	32.8
	40	36	39.5	38.6	37.5	36.8	36.3	35.0
	45	41	41.9	40.9	39.7	39.1	38.6	37.2
	47	43	42.8	41.9	40.7	<b>40.00</b>	39.5	38.0
	50	46	42.9	42.1	41.0	40.4	40.0	38.6
	55	51	43.2	42.4	41.7	41.2	40.8	39.6
	60	56	43.4	42.8	42.3	41.9	41.6	40.6
	63	59	43.5	43.0	42.6	42.4	42.1	41.1
68	64	43.6	43.2	43.0	42.8	42.6	41.7	

TC = Total Capacity (kBtu/h).

Nominal capacity as rated 0 ft. above sea level and a 0 ft. level difference between outdoor and indoor units. Corresponding refrigerant piping length is accordance with standard length of each outdoor unit. Nominal heating capacity rating obtained with air entering the indoor unit at 70°F dry bulb (DB) and 60°F wet bulb (WB), and outdoor ambient conditions of 47°F dry bulb (DB) and 43°F wet bulb (WB).

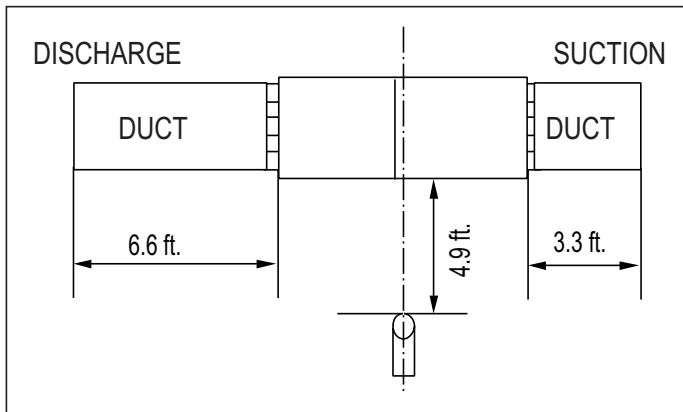
Table 68: Multi F Mid Static Duct External Static Pressure Setting Values Table.

Static Pressure (in. wg)			0.16	0.2	0.24	0.28	0.31	0.35	0.39	0.43	0.47	0.51	0.59
Model No. / Nominal Capacity of Indoor Unit (Btu/h)	Airflow Rate / CFM												
	KNUJB301A 30,000	High	989	92	96	99	101	105	108	115	118	124	124
Mid		848	88	92	94	95	100	101	108	113	118	118	118
Low		741	84	88	89	90	95	96	100	105	110	112	113
KNUJB361A 36,000	High	1,130	109	112	115	119	122	126	128	131	134	137	144
	Mid	989	101	105	108	112	115	119	123	127	130	133	138
	Low	848	92	97	101	105	109	113	117	121	124	127	134

**NOTICE**

- To get the desired air flow and external static pressure combination, use the setting value from the table. Using a setting value other than that listed in the table will not provide the desired combination.
- Table data is based at 230V. Air flow rate varies according to voltage fluctuation.

Figure 156: Sound Pressure Level Measurement Location.

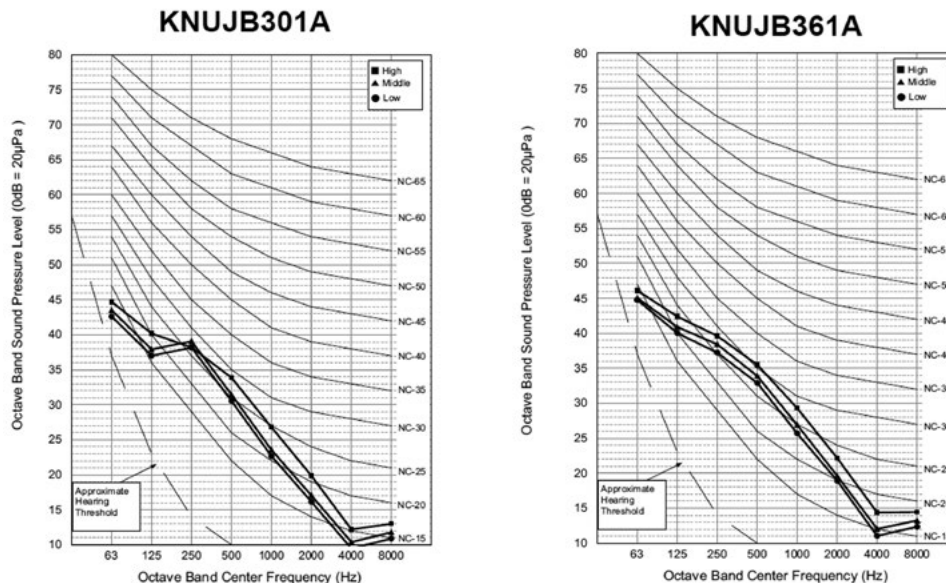


- Measurements taken with no attenuation and units operating at full load normal operating condition.
- Sound level will vary depending on a range of factors such as construction (acoustic absorption coefficient) of particular area in which the equipment is installed.
- Sound power levels are measured in dB(A).
- Tested in anechoic chamber per ISO Standard 3745.

Table 69: Sound Pressure Levels (dB[A]).

Model No.	Sound Pressure Levels (dB[A]) Cooling and Heating		
	High Fan Speed	Medium Fan Speed	Low Fan Speed
KNUJB301A	34	33	32
KNUJB361A	36	34	33

Figure 157: Sound Pressure Level Diagrams.



# MID STATIC DUCT INDOOR UNITS

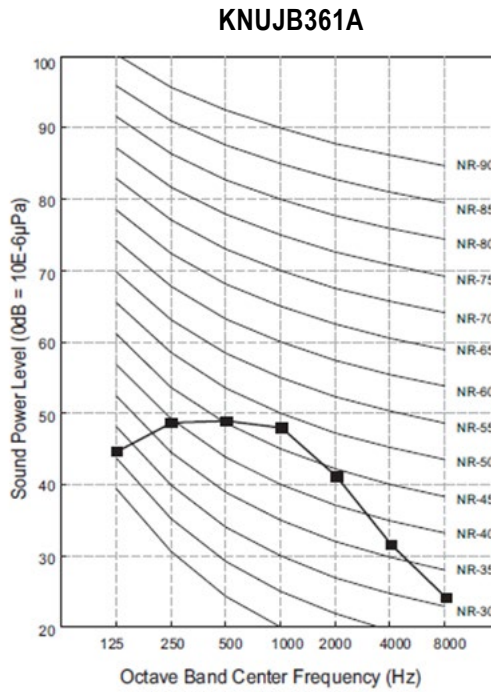
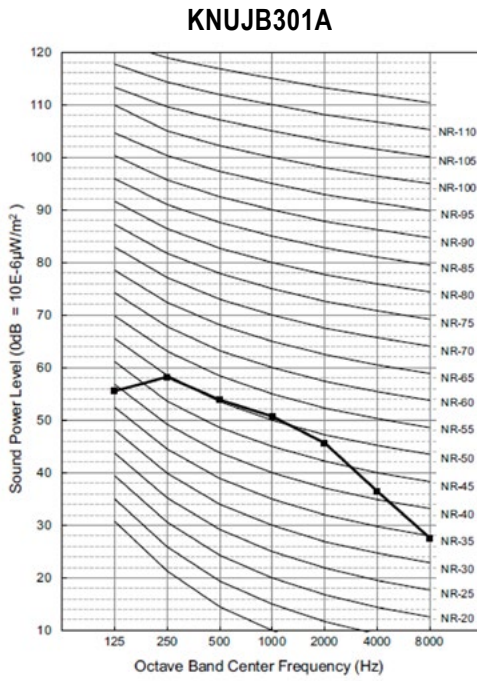
## Acoustic Data

MULTI F  
MULTI F MAX

Table 70: Sound Power Levels (dB[A]).

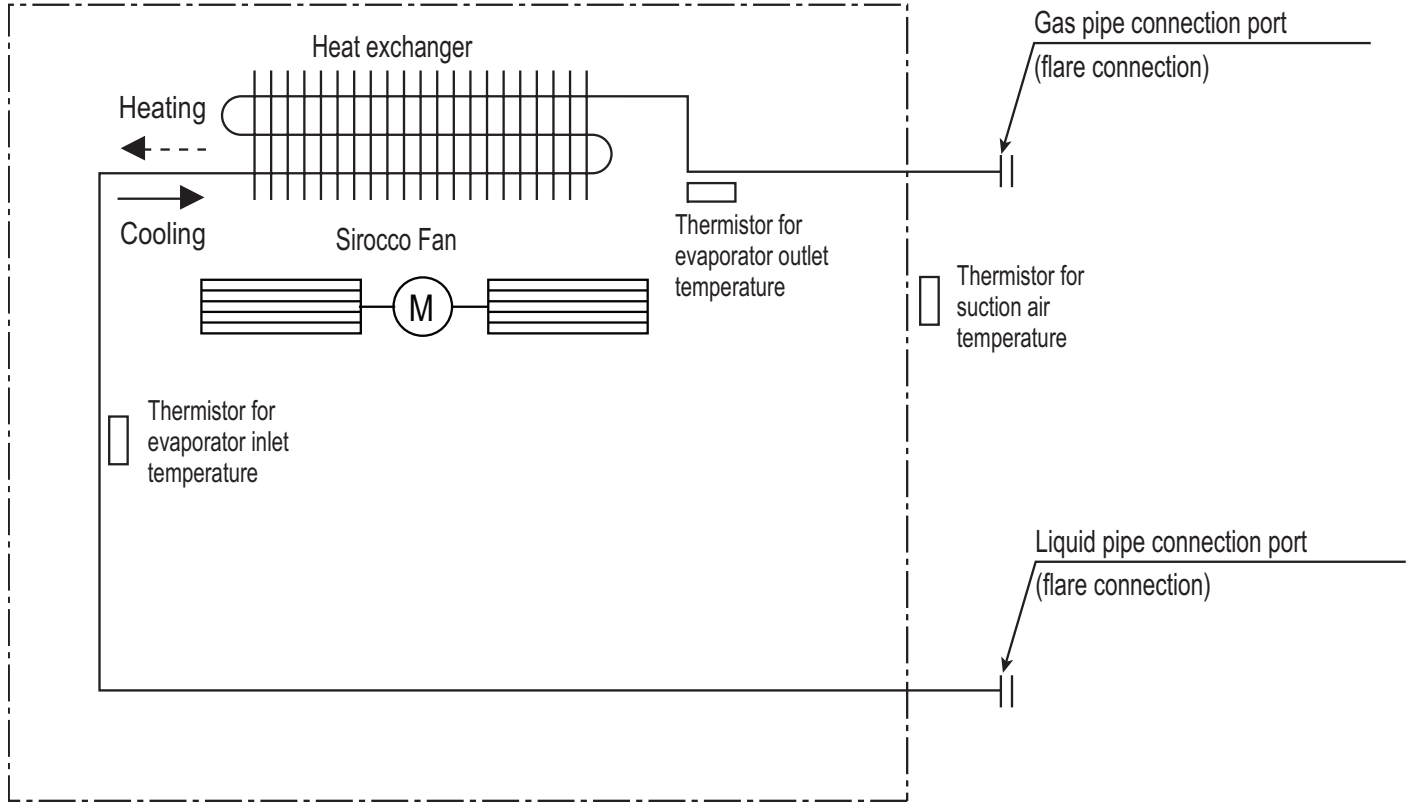
Model No.	Sound Power Levels (dB[A])
KNUJB301A	59
KNUJB361A	60

Figure 158: Sound Power Level Diagrams.



Multi F and Multi F MAX Indoor Unit Engineering Manual

Figure 159: KNUJB301A and KNUJB361A Refrigerant Flow Diagram.



Mid Static Duct

Table 71: Multi F Mid Static Duct IDU Refrigerant Piping and Connection Sizes.

Model No.	Piping Size		Connection Port Size	
	Liquid (inch)	Vapor (inch)	Liquid (inch)	Vapor (inch)
KNUJB301A	3/8	5/8	3/8	5/8
KNUJB361A	3/8	5/8	3/8	5/8

Table 72: Multi F Mid Static Duct Indoor Unit Thermistor Details.

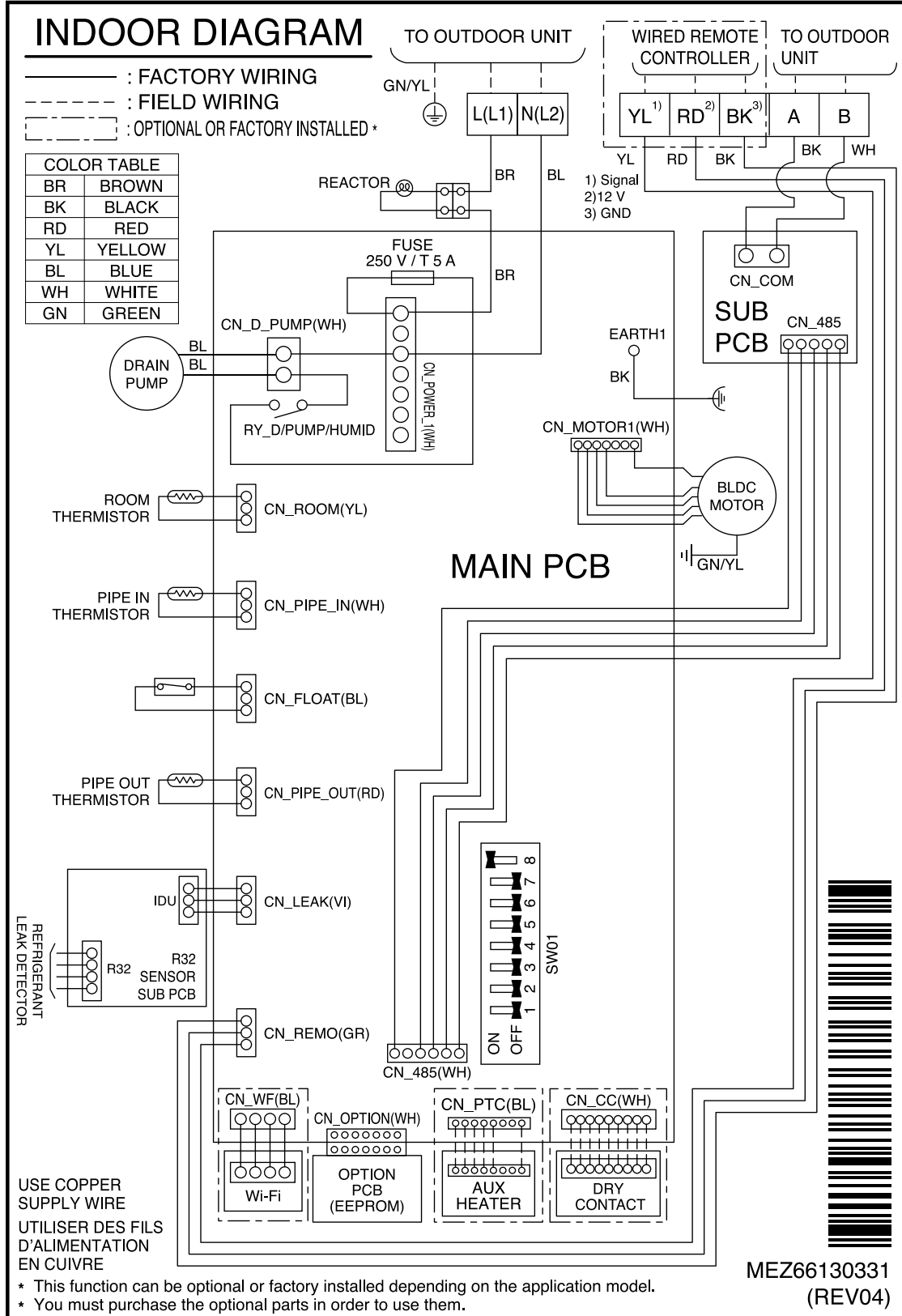
Description (Based on Cooling Mode)	PCB Connector
Indoor Air Temperature Thermistor	CN_ROOM
Evaporator Inlet Temperature Thermistor	CN_PIPE_IN
Evaporator Outlet Temperature Thermistor	CN_PIPE_OUT

# MID STATIC DUCT INDOOR UNITS

## Wiring Diagrams

MULTI F  
MULTI F MAX

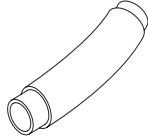



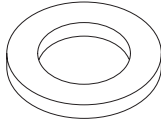
Figure 160: Multi F Mid Static Duct KNUJB301A and KNUJB361A Indoor Units Wiring Diagram.



Multi F and Multi F MAX Indoor Unit Engineering Manual

## Factory Supplied Parts

Table 73: Parts Table.

Part	Quantity	Image	Part	Quantity	Image
Drain Hose	One (1)		Zip Ties	Four (4)	
Metal Clamp	Two (2)		Insulation for Fittings	One (1) Set	 For Vapor Piping    For Liquid Piping
Washers for Hanging Brackets	Eight (8)				

## Factory Supplied Materials

- Owner's Manual
- Installation Manual

## Required Tools

- Level
- Screwdriver
- Electric drill
- Hole core drill
- Flaring tool set
- Torque wrenches
- Hexagonal wrench
- Gas-leak detector
- Thermometer

## ⚠ WARNING

Installation work must be performed by trained personnel and in accordance with national wiring standards and all local or other applicable codes. Improper installation can result in fire, electric shock, physical injury, or death.

## NOTICE

Read all instructions before installing this product. Become familiar with the unit's components and connections, and the order of installation. Incorrect installation can degrade or prevent proper operation.

## Selecting the Best Location

### Do's

- Place the unit where air circulation will not be blocked.
- Place the unit where drainage can be obtained easily.
- Place the unit where noise prevention is taken into consideration.
- Ensure there is sufficient strength to bear the load of the indoor unit.
- Ensure there is sufficient maintenance space.
- Locate the indoor unit in a location that is level, and where it can be easily connected to the outdoor unit / branch distribution unit.

### ⊘ Don'ts

- ⊘ Do not install the unit near a heat or steam source, or where considerable amounts of oil, iron powder, or flour are used.
- ⊘ Do not install the unit where sulfuric acid and flammable or corrosive gases are generated, vented into, or stored.
- ⊘ Do not install the unit near high-frequency generators.
- ⊘ Do not install the unit near a doorway.


**The unit will be damaged, will malfunction, and / or will not operate as designed if installed in any of the conditions listed.**

# MID STATIC DUCT INDOOR UNITS

## Installation and Best Layout Practices

MULTI F  
MULTI F MAX

### NOTICE

-  Indoor units (IDUs) must not be placed in an environment where the IDUs will be exposed to harmful volatile organic compounds (VOCs) or in environments where there is improper air make up or supply or inadequate ventilation. If there are concerns about VOCs in the environment where the IDUs are installed, proper air make up or supply and/or adequate ventilation must be provided. Additionally, in buildings where IDUs will be exposed to VOCs, consider a third party factory-applied epoxy coating to the fan coils for each IDU where the entire coil is dipped, not sprayed.
- If the unit is installed near a body of water, the installation parts are at risk of corroding. Appropriate anti-corrosion methods must be taken for the unit and all installation parts.

### Installing in an Area Exposed to Unconditioned Air

In some installation applications, areas (floors, walls) in some rooms will be exposed to unconditioned air (room will be above or next to an unheated garage or storeroom). To countermeasure:

- Verify that carpet is or will be installed (carpet will increase the temperature by three degrees).
- Add insulation between the floor joists.
- Install radiant heat or another type of heating system to the floor.

### Installing in an Area with High Humidity Levels

If the environment is prone to humidity levels of 80% or more (near the ocean, lakes, etc.) or where steam could collect in the plenum:

- Install additional insulation to the indoor unit (glass wool insulation >13/32 inches thick).
- Install additional insulation to the refrigerant piping (insulation >13/16 inches thick).
- Seal all gaps between the indoor unit and the ceiling tiles (make the area air tight) so that humidity does not transfer from the plenum to the conditioned space. Also, add a ceiling grille for ventilation.

Figure 161: Access Panel and General Service Space Required Dimensions.

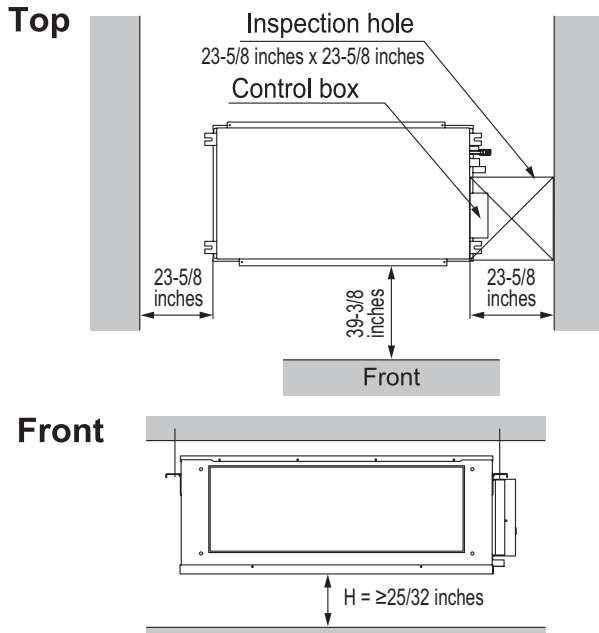


Figure 162: Indoor Unit Bolt Locations.

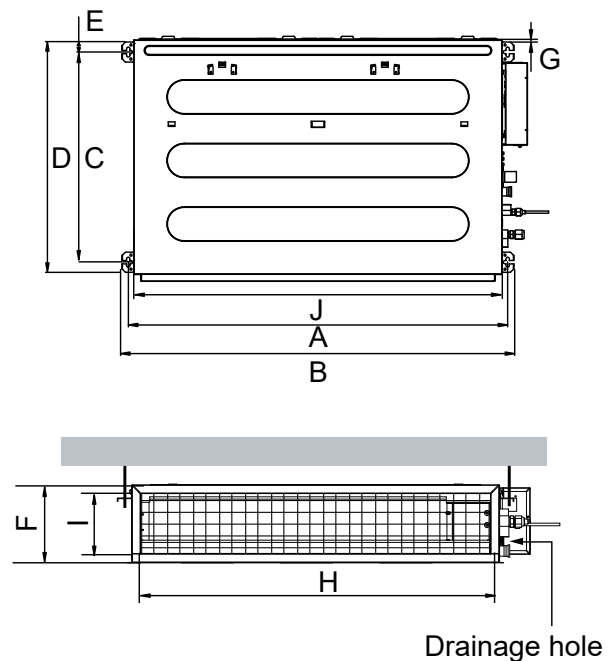


Table 74: Indoor Unit Bolt Location Dimensions.

Model / Capacity (Btu/h)	Dimensions (inches)									
	A	B	C	D	E	F	G	H	I	J
KNUJB301A / 30,000	50-17/32	52-1/32	24-3/8	27-9/16	1-3/16	10-5/8	19/32	47-9/16	7-15/16	49-7/32
KNUJB361A / 36,000	50-17/32	52-1/32	24-3/8	27-9/16	1-3/16	10-5/8	19/32	47-9/16	7-15/16	49-7/32

### Preparing the Installation Area and Hanging the Indoor Unit Frame

1. Select and mark the area for the suspension or console bolts (use embedded inserts or anchor bolts in new buildings, and hole-in-anchors in older buildings).
2. Drill the holes.
3. Add the set-anchor and the plate washer to the bolts (bolts must be at least 13/32 inches in diameter), and then insert the bolts into the installation area.
4. Add the plate washer, spring washer, and nut to secure the bolts into the installation area.
5. Position the indoor unit installation plates onto the bolts. Secure using nuts, plate washers, and spring washers. Adjust for level as necessary.

Figure 163: Preparing the Installation Area.

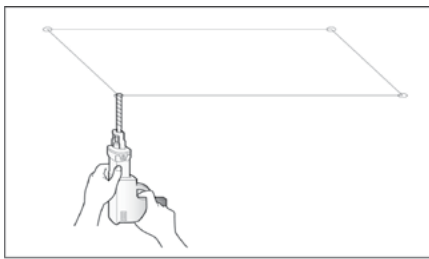


Figure 164: Suspension Bolt Options.

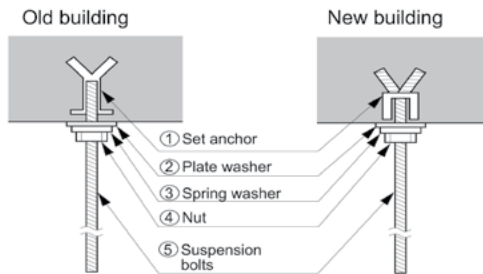
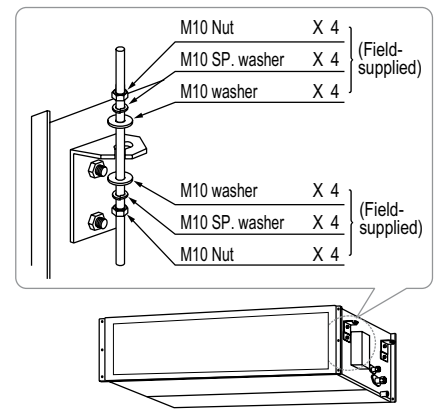


Figure 165: Hanging the Indoor Unit.



#### NOTICE

Install a canvas duct to the air outlet and air inlet so that vibration from the indoor unit does not carry to the duct or ceiling. Also, add insulation to the interior of the duct, and apply anti-vibration to the suspension bolts.

#### WARNING

- Unit must be installed correctly. Tighten the nuts and bolts to prevent the unit from falling and causing severe injury or death.

### Installing the Drain System

- Drain piping must have downward gradient of at least 1/50 to 1/100; to prevent reverse flow, slope must not be straight up and down.
- Do not damage the drain port on the indoor unit when connecting the field-supplied drain piping.
- Drain piping specifications:
  - Indoor Unit Drain Connection: 1-1/4 inch outside diameter.
  - Field-Supplied Drain Piping: Polyvinyl chloride piping with 1-inch inside diameter and pipe fittings.

Figure 167: Drain Piping Installation Dimensions.

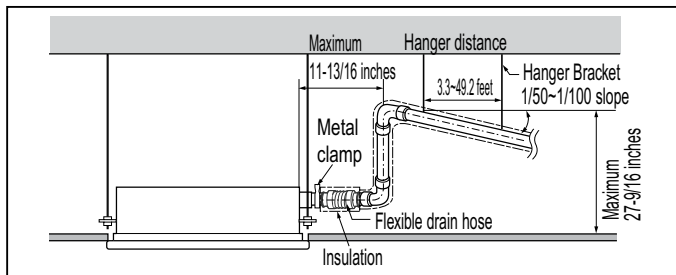
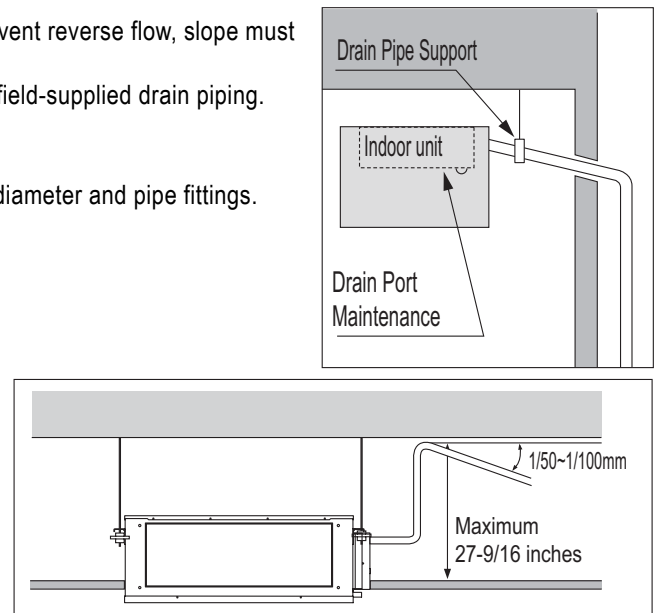


Figure 166: Indoor Unit Drain Piping.



#### NOTICE

- Do not apply force or twist the drain hose: it will leak.

# MID STATIC DUCT INDOOR UNITS

## Installation and Best Layout Practices

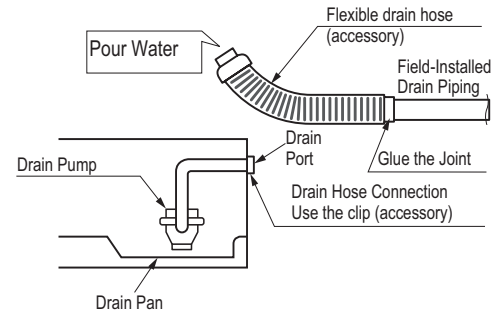
MULTI F  
MULTI F MAX

### Checking the Drain Pump

The unit uses a drain pump to remove condensate. The pump must be tested before the system operates.

- Connect (field supplied) flexible drain hose to the field-installed drain piping; leave it as is until the test is complete.
- Pour water into the flexible drain hose and check for leaks.
- After power wiring installation is complete, operate the drain pump to see if it sounds and functions properly.
- After the test is complete, connect the flexible drain hose to the indoor unit drain port.

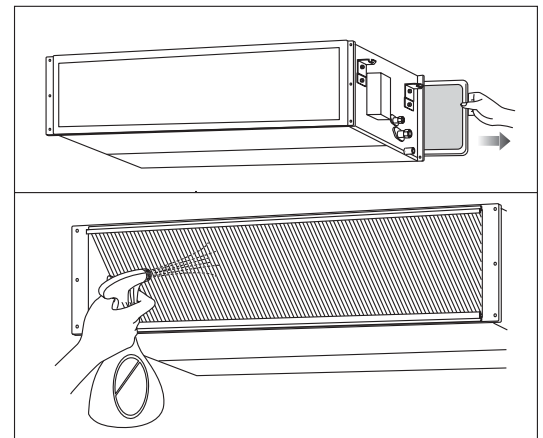
Figure 168: Checking the drain pump.



### Checking the Drainage System

1. Remove the air filter.
2. Check the drainage.
  - Spray water on the evaporator.
  - Verify that water flows through the indoor unit drain hose without leaking.

Figure 169: Checking the Drainage System.



### Insulating the Refrigerant and Drain Piping

#### ⚠ WARNING

Ensure all piping is insulated. Exposed piping can cause burns if touched.

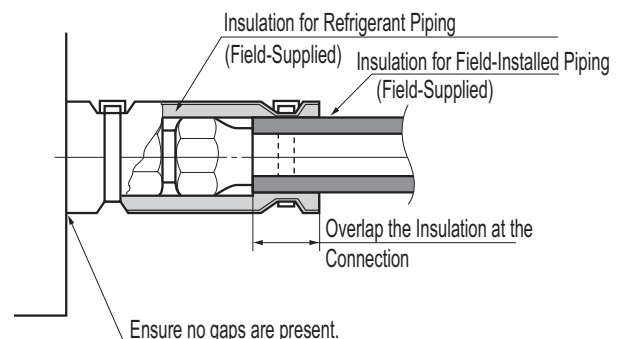
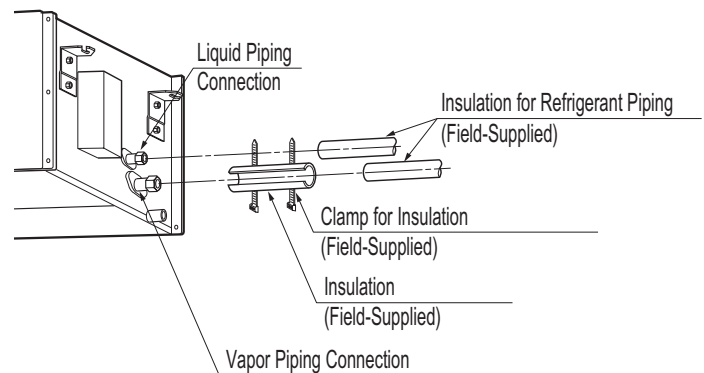
#### Refrigerant Piping Insulation

Field-installed vapor and liquid refrigerant piping lines must be properly and completely covered in insulation (up to the indoor unit piping connections). Any exposed piping will generate condensate or will cause burns if touched. Insulation for this field-installed refrigerant piping must have a minimum heat resistance of 248°F.

#### Drain Piping Insulation

Drain piping must have insulation a minimum of 7/32 inches thick.

Figure 170: Insulating the Piping.



### Power Wiring / Communications Cable Guidelines

- Follow manufacturer's circuit diagrams in the technical manuals.
- Confirm power source specifications.
- Confirm that the electrical capacity is sufficient.
- Starting current must be maintained  $\pm 10$  percent of the rated current marked on the outdoor unit name plate.
- Confirm cable thickness specifications.
- It is required that a circuit breaker is installed, especially if conditions could become wet or moist.
- Include a disconnect in the power wiring system, add an air gap contact separation of at least 1/8 inch in each active (phase) conductor.

### ⚠ WARNING

- Loose wiring will cause unit to malfunction, overheat, and catch fire, resulting in severe injury or death.

### NOTICE

- Terminal screws will become loose during transport. Properly tighten the terminal connections during installation.
- A voltage drop will cause the following problems:
- Magnetic switch vibration, fuse breaks, or disturbance to the normal function of an overload protection device.
  - Compressor will not receive the proper starting current.

### Connecting the Power Wiring and Communications Cable

1. To access the terminal block, first unscrew the cover from the control box.
2. Insert the power wiring / communications cable from the outdoor unit or branch distribution unit (Multi F MAX systems only) through the sides of the indoor unit and control box. Pass the wiring through the designated access holes to prevent damage. To prevent electromagnetic interference and product malfunction, leave a space between the power wiring and communications cable outside of the indoor unit.
3. Connect each wire to its appropriate terminal on the indoor unit control board. Verify that the color and terminal numbers from the outdoor unit or branch distribution unit (Multi F MAX systems only) wiring match the color and terminal numbers on the indoor unit.
4. Secure the power wiring / communications cable with the cable restraint.
5. Screw the steel clamp to the inside of the control panel.
  - Place the wiring / cables in the clamp and tighten the plastic clamp to an open surface of the control panel.
  - When clamping, ⚠ do not apply force to the wiring connections.
  - Neatly arrange the wiring, ⚠ do not catch the wiring in the electric box cover, and ensure the cover firmly closes.
6. Fill in any gaps around the wiring access holes with sealant to prevent foreign particles from entering the indoor unit.

Figure 171: Access Holes Location.

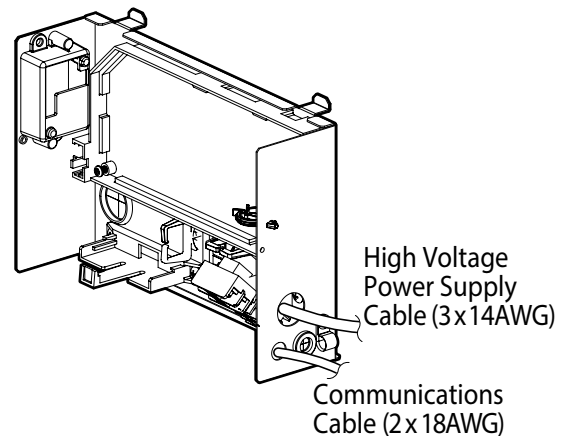
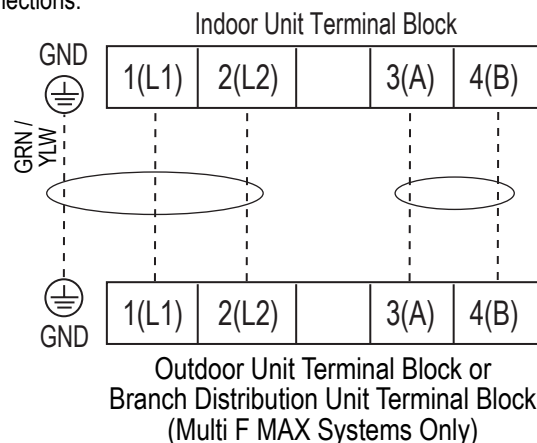


Figure 172: Indoor Unit to Outdoor Unit / Branch Distribution Unit (Multi F MAX systems only) Power Wiring / Communications Cable Connections.



# MID STATIC DUCT INDOOR UNITS

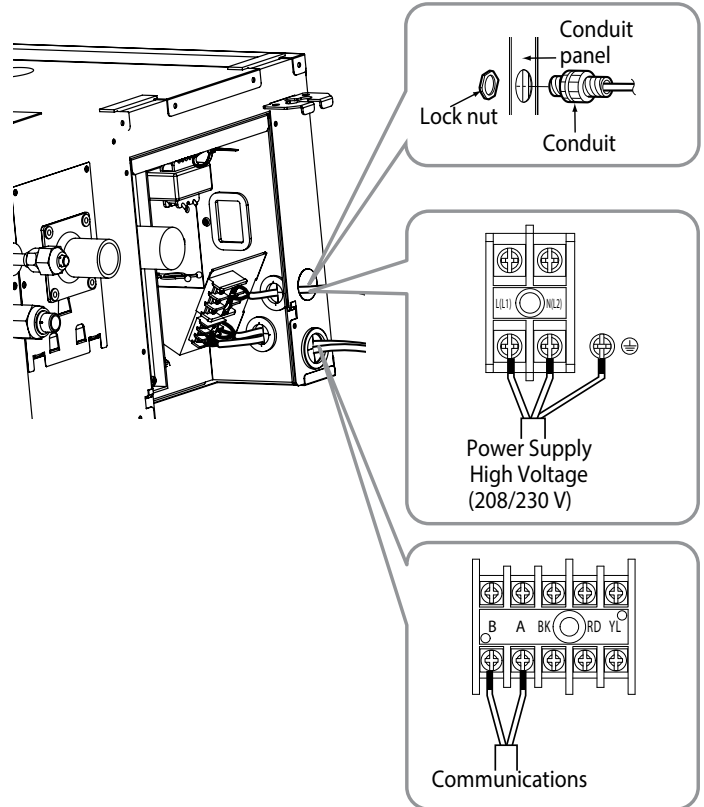
## Installation and Best Layout Practices

MULTI F  
MULTI F MAX

### Using a Conduit

1. Remove the rubber stopper on the indoor unit. Pass the power wiring / communications cable through the conduit, the conduit mounting plate, and to / through the control panel of the indoor unit.
2. Connect the power wiring / communications cable to the indoor unit terminal block.
3. Screw the conduit mounting plate to the indoor unit.
4. Tighten the conduit and the conduit mounting plate together.

Figure 173: Exterior View of Conduit Installation.



### Controller Options

Mid Static Duct indoor units can be used with many LG-supplied wired controllers (sold separately). The wireless handheld controller (Model No. PWLSSB21H) is also an optional accessory with use of the wired controller.

### Wired Controller Connections

Controllers can connect to the indoor unit in one of two different ways.

1. LG Wired Remote Extension Cable with Molex plug (PZCWRC1; sold separately) that connects to the CN-REMO terminal on the indoor unit PCB.
2. Field-supplied controller cable that connects to the indoor unit terminal block (must be at least UL2547 or UL1007, 22 AWG, two-core, one-shield core, at least FT-6 rated if local electric and building codes require plenum cable usage).

Figure 174: PZCWRC1 LG Wired Remote Extension Cable.

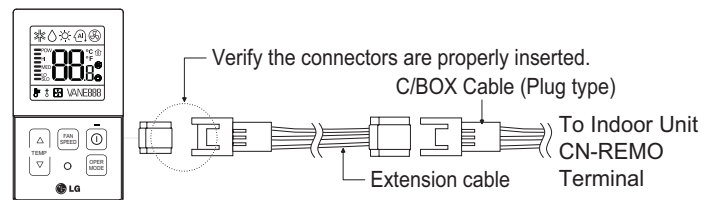
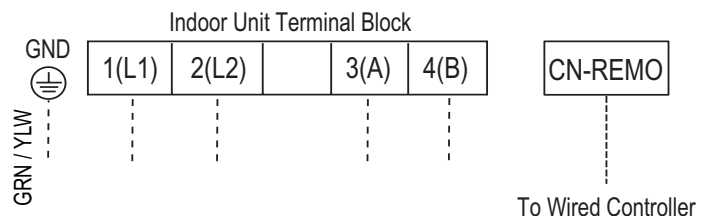


Figure 175: Wired Controller Connections on the Indoor Unit Terminal Block.



### NOTICE

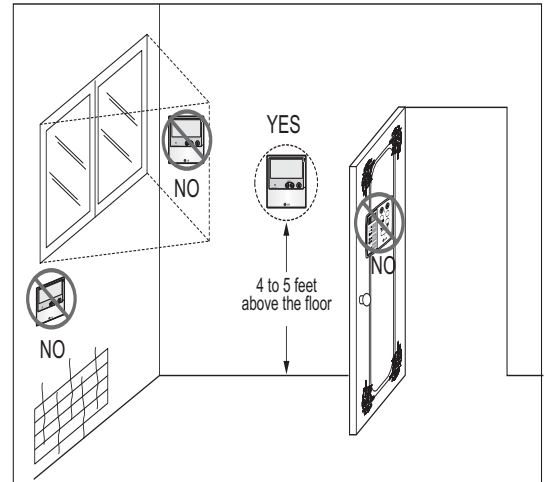
When using field-supplied controller cable, make sure to connect the yellow to yellow (communications wire), red to red (12V power wire), and black to black (ground wire) terminals from the remote controller to the indoor unit terminal blocks.

### Wired Controller Placement

Wired controllers include a sensor to detect room temperature. To maintain comfort levels in the conditioned space, the wired controller must be installed in a location away from direct sunlight, high humidity, and where it could be directly exposed to cold air. Controller must be installed four (4) to five (5) feet above the floor where its LED display can be read easily, in an area with good air circulation, and where it can detect an average room temperature.

- ⊘ Do not install the wired controller near or in:
  - Drafts or dead spots behind doors and in corners
  - Hot or cold air from ducts
  - Radiant heat from the sun or appliances
  - Concealed pipes and chimneys
  - An area where temperatures are uncontrolled, such as an outside wall

Figure 176: Proper Location for the Wired Controller.



### Hanging the Wired Controller

1. The controller wiring / cable can be installed in one of three directions: top, back, or on the right side. If top or right side installation is desired, remove cable guide grooves on the controller, and then position wiring / cable on applicable side.
2. Choose and mark the area of installation, and then screw the wall plate into place (using the provided parts). Install the controller wall plate to fit the electrical box if one is present. Ensure that no gaps exist between the wall plate and the wall itself.
3. Arrange wiring / cables so as not to interfere with the controller circuitry. Position the wired controller on the wall plate. Snap into place by pressing the bottom part of the wired controller onto the wall plate. Make sure that no gaps exist between the wired controller and the wall plate on all sides.
4. To remove wired controller from the wall plate, insert a screwdriver into the two holes at the bottom. Twist screwdriver to release controller. ⊘ Do not damage the controller components when removing.

Figure 177: Removing the Cable Guide Grooves.

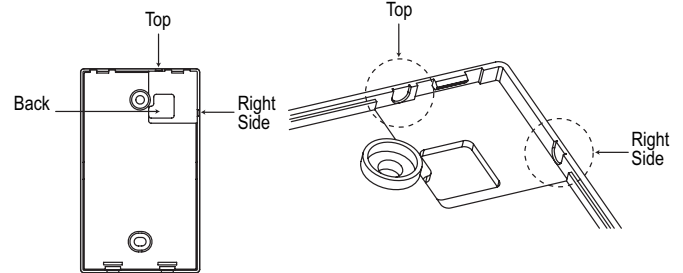


Figure 178: Attaching the Wall Plate.

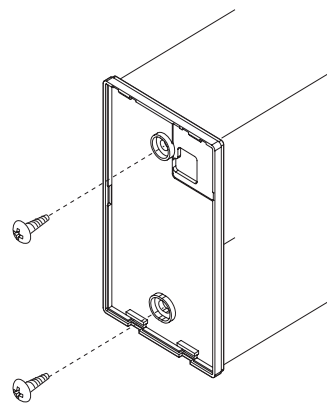
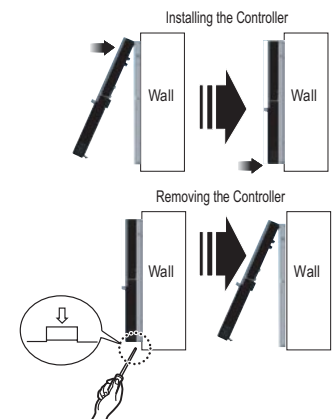


Figure 179: Installing / Removing the Controller.



### Assigning the Thermistor for Temperature Detection

Each indoor unit includes a return air thermistor assigned to sense the temperature. If a wired controller is installed, there is a choice of sensing temperature with either the indoor unit return air thermistor or the thermistor in the wired controller. It is also an option to set both thermistors to sense temperature so that indoor unit bases its operation on the first thermistor to reach the designated temperature differential. For applicable indoor units, an optional Remote Temperature Sensor can be used in lieu of the return air thermistor—either alone or in conjunction with a wired controller thermistor as previously described.

# MID STATIC DUCT INDOOR UNITS

## Installation and Best Layout Practices

MULTI F  
MULTI F MAX

### External Static Pressure Control

To provide a required air flow rate that accounts for the external static pressure change, follow the steps below.

1. To access system installer setting mode, press and hold the temperature increase and mode selection buttons simultaneously for approximately three (3) seconds. Choose setting code value "06" by pressing the mode selection button.
2. Use the temperature increase and decrease buttons to select the desired setting value.

#### Setting Values

- 01 : V-H
- 02 : F-H
- 03 : V-L
- 04 : F-L

3. Press the on / off button to save the established settings.
4. To deactivate system installer setting mode after the settings have been established, press and hold the temperature increase and mode selection check buttons simultaneously for approximately three (3) seconds. If a button is not pressed for more than 25 seconds, the system installer setting mode will automatically deactivate.

Figure 180: Select Code and Set Value.

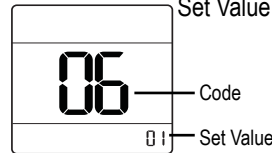


Figure 181: Controller External Static Pressure Setting Display.

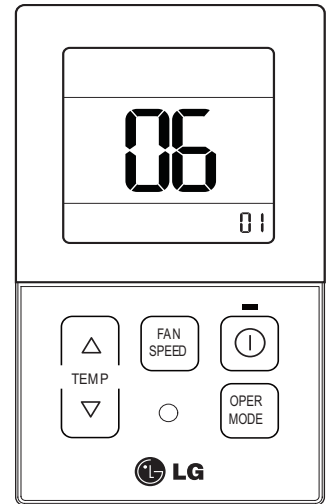


Table 75: Static Pressure Setting Table.

Pressure Selection		Function	
		Zone State	External Static Pressure Standard Value
01	V-H	Variable	High
02	F-H	Fixed	High
03	V-L	Variable	Low
04	F-L	Fixed	Low

#### NOTICE

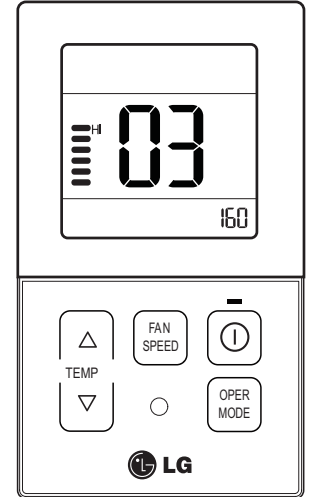
- Select the position after verifying duct work and the external static pressure of the indoor unit.
- Factory set to pressure selection F-H.

### Assigning Air Flow

To assign an air flow for each fan speed, follow the steps below.

1. To access system installer setting mode, press and hold the temperature increase and mode selection buttons simultaneously for approximately three (3) seconds. Choose setting code value "03" by pressing the mode selection button.
2. Use the fan speed button to select the desired fan speed. ( Lo→Med→Hi will display on the LED).
3. Use the temperature increase and decrease buttons to select the desired external static pressure setting value (thereby assigning the respective airflow). External static pressure value range: 0~255; the value will display near the lower right corner of the LED.
4. Press the on / off button to save the established settings.
5. To deactivate system installer setting mode after the settings have been established, press and hold the temperature increase and mode selection check buttons simultaneously for approximately three (3) seconds. If a button is not pressed for more than 25 seconds, the system installer setting mode will automatically deactivate.

Figure 182: Controller External Static Pressure Setting Display.



### NOTICE

- A trained technician must set the external static pressure value(s). If the external static pressure is set incorrectly, the system will malfunction.
- Do not alter the external static pressure value that corresponds to each air flow level.
- External static pressure value can vary depending on the indoor unit.
- If by pressing the fan speed button during external static pressure setup, the fan speed is raised to the next level, the air flow value of the previous fan speed will be maintained (external static pressure setting value is saved).

# FOUR-WAY CEILING-CASSETTE INDOOR UNIT DATA

**Mechanical Specifications on page 143**

**General Data / Specifications on page 144**

**Dimensions on page 145**

**Cooling Capacity Table on page 147**

**Heating Capacity Table on page 149**

**Acoustic Data on page 151**

**Air Velocity and Temperature Distribution on page 153**

**Refrigerant Flow Diagram on page 155**

**Wiring Diagram on page 156**

**Factory Supplied Parts and Materials on page 157**

**Installation and Best Layout Practices on page 158**

### Four-Way Ceiling-Cassette Indoor Units

#### General

All LG indoor units are factory assembled, wired, piped, and provided with a control circuit board, fan, and motor. Four-way ceiling-cassette units have a sound rating no higher than 41 dB(A) as tested per KSA0701 ISO Standard 3745.

#### Coil

Indoor unit coils are factory built and are comprised of aluminum fins mechanically bonded to copper tubing. Each unit has a refrigerant coil which has been pressure tested at the factory. Each unit is provided with a factory installed condensate drain pan below the coil.

#### Refrigerant System

System is designed for use with R32 refrigerant. The refrigeration circuit is pressure-tested at the factory and shipped with a holding charge of helium gas. Refrigerant pipe connections are 45° flare, and all refrigerant lines from the outdoor unit to the indoor units must be field insulated.

#### Electrical

Each indoor unit is designed to operate using 208–230/60/1 power with voltage variances of ±10%.

#### Casing

The case is constructed of a galvanized steel plate designed to recess in the ceiling, and has a surface mounted concentric grille on the bottom of the unit. Unit has four supply air outlets and one return air inlet.

#### Ventilation Air

The case has a factory designated knockouts to connect a field-supplied, pressurized, and filtered outside air duct.

#### Fan Assembly and Control

All indoor units have a single, direct-drive turbo fan. Fans are manufactured of high-strength ABS HT-700 polymeric resin that is statically and dynamically balanced. The fan motor is brushless digitally controlled (BLDC) with permanently lubricated and sealed ball bearings. The fan / motor assembly is mounted on vibration-attenuating rubber grommets. Fan speed is controlled using a microprocessor-based direct digital control algorithm that provides pre-programmed, field-selectable fixed or auto fan speeds in the Heating and Cooling modes.

The indoor fan has Low, Med, High, Power Cool and Auto settings for Cooling mode; and has Low, Med, High, and Auto settings for Heating mode. Auto setting adjusts the fan speed based on the difference between the controller setpoint and space temperature.

#### Air Filter

Return air is filtered with a factory-supplied, 14" x 14" x 1", removable, washable filter accessible from the bottom of the unit.

#### Architectural Grille

An architectural grille is sold as a separate required accessory. The four-way grille is off-white acrylonitrile butadiene styrene (ABS) polymeric resin with a tapered trim edge.

#### Airflow Guide Vanes

The supply air outlet has four-directional slot diffusers, each equipped

### Features

- Inverter (Variable speed fan)
- Internal drain pump
- Jet cool
- Control lock function
- Auto operation
- Auto restart operation
- 24-Hour on/off timer
- Two thermistor control
- Required accessory grille (PT-QAGW0) sold separately
- Group Control
- Wireless LCD remote control included; wired thermostat available (sold separately)
- Wi-Fi compatible



Figure 183: Multi F Four-Way Ceiling-Cassette Indoor Unit.



with an independent oscillating motorized guide vane to change airflow direction. A guide vane algorithm sequentially changes the predominant discharge airflow direction in counter-clockwise pattern, or can be used to lock each guide vane independently in a field-adjusted fixed position. The four vanes can be individually adjusted from the wired remote controller to customize the airflow pattern for the conditioned space. A setting in the cooling and heating modes can cycle the vanes up and down for uniform / random air distribution.

#### Microprocessor Control

The indoor unit is provided with an integrated control panel to communicate with the outdoor unit. All unit operation parameters are stored in non-volatile memory residing on the unit microprocessor. The microprocessor controls space temperature through using the value provided by the temperature sensor within the indoor unit. The microprocessor control will activate indoor unit operation when the indoor room temperature falls below or rises above a setpoint temperature, at which point, a signal is sent to the outdoor unit to begin the appropriate mode. The microprocessor will also provide self-diagnostics and auto restart functions. A field-supplied three-wire power cable (3 x 14 AWG) and two-wire communications cable (2 x 18 AWG) must be installed to connect the indoor unit(s) to the outdoor unit.

The indoor units are Wi-Fi compatible with the addition of an LG Wi-Fi module accessory, and can be controlled by LG's Smart ThinQ™ app on a smart device. A field-supplied Wi-Fi network and smart device are required. The Smart ThinQ app is free, and is available for Android™ and iOS. (Android is a trademark of Google LLC.)

#### R32 Refrigerant Leak Detector

The indoor unit has a built-in R32 refrigerant leak detection sensor designed to communicate with release mitigation devices and third party alarms, and transmit a system error code upon detection of a refrigerant leak or sensor failure / expiration.

#### Shut-off Valve

LG single-port shutoff valve (PRHPZ010A; sold separately) is available as an accessory.

#### Controls

The accessory grille has a factory-standard, integral infrared sensor designed to communicate with the supplied LG wireless handheld remote controller. An optional wired controller is available as an additional accessory. Communication between the indoor units and the outdoor unit is accomplished through 18 AWG, two-core, stranded and shielded communication cable.

#### Condensate Lift/Pump

The indoor unit is provided with a factory installed and wired internal condensate lift/pump capable of providing a minimum 27.5 inch lift from the bottom surface of the unit. Drain pump has a safety switch to shut off the indoor unit if the condensate rises too high in the drain pan.

# FOUR-WAY CEILING-CASSETTE INDOOR UNITS

## General Data / Specifications

**MULTI F**  
**MULTI F MAX**

Table 82: Multi F Four-Way Ceiling-Cassette Indoor Unit General Data.

Model Name	KNMDB071A	KNUDB091A	KNUDB121A	KNUDB181A
<b>Grille (Sold Separately)</b>	<b>PT-QAGW0</b>	<b>PT-QAGW0</b>	<b>PT-QAGW0</b>	<b>PT-QAGW0</b>
Nominal Cooling Capacity (Btu/h) <sup>1</sup>	7,000	9,000	12,000	18,000
Nominal Heating Capacity (Btu/h) <sup>1</sup>	8,100	10,400	13,800	20,800
<i>Operating Range</i>				
Cooling (°F WB)	57-77			
Heating (°F DB)	59-81			
Fan				
Type	Turbo			
Motor Output (W) x Qty.	43 x 1			
Motor/Drive	Brushless Digitally Controlled / Direct			
Airflow Rate CFM (H/M/L)	265 / 212 / 177	300 / 265 / 230	335 / 283 / 247	459 / 424 / 388
<i>Unit Data</i>				
Refrigerant Type <sup>2</sup>	R32			
Refrigerant Control	EEV			
Power Supply V, Ø, Hz <sup>3</sup>	208-230, 1, 60			
Rated Amps (A)	0.25			
Sound Pressure Level dB(A) (H/M/L) <sup>4</sup>	31 / 27 / 24	36 / 33 / 30	38 / 35 / 32	41 / 39 / 36
Body Dimensions (W x H x D, in.)	22-7/16 x 8-7/16 x 22-7/16			22-7/16 x 10-3/32 x 22-7/16
Grille (Sold separately) Dimensions (WxHxD, in.)	24-13/32 x 1-11/32 x 24-13/32			
Body Net Weight (lbs.)	25.6	28.4	30.9	
Grille (Sold separately) Net Weight (lbs.)	6.3			
Body Shipping Weight (lbs.)	31.1	34	37	
Grille (Sold separately) Shipping Weight (lbs.)	8.6			
Power Wiring Cable (No. x AWG) <sup>5</sup>	3 x 14			
Communications Wiring Cable (No. x AWG) <sup>5</sup>	2 x 18			
Heat Exchanger (Row x Column x Fin / inch) x Number	(1 X 8 X 18) X 1	(2 x 8 x 18) x 1		(2 x 10 x 18) x 1
Dehumidification Rate (pts./hr)	1.2	1.5	2.5	3.1
<i>Pipe Size</i>				
Liquid (in.)	1/4			
Vapor (in.)	3/8			1/2
<i>Connection Size</i>				
Liquid (in.)	1/4			
Vapor (in.)	3/8			1/2
Drain O.D. / I.D. (in.)	1-1/4, 1			

<sup>1</sup>Nominal capacity is rated 0 ft. above sea level with a 0 ft. level difference between outdoor and indoor units. All capacities are net with a combination ratio between 95 – 105%.

Nominal cooling capacity rating obtained with air entering the indoor unit at 80°F dry bulb (DB) and 67°F wet bulb (WB) and outdoor ambient conditions of 95°F dry bulb (DB) and 75°F wet bulb (WB).  
Nominal heating capacity rating obtained with air entering the indoor unit at 70°F dry bulb (DB) and 60°F wet bulb (WB) and outdoor ambient conditions of 47°F dry bulb (DB) and 43°F wet bulb (WB).

<sup>2</sup>This unit comes with a dry helium charge.

<sup>3</sup>Acceptable operating voltage: 187V-253V.

<sup>4</sup>Sound pressure levels are tested in an anechoic chamber under ISO Standard 3745 and are the same in both cooling and heating mode. These values can increase due to ambient conditions during operation.

<sup>5</sup>The power wiring and the communication wiring from the outdoor unit to the indoor unit, or from the branch distribution unit to the indoor unit is field supplied and must be stranded, shielded or unshielded (if shielded, it must be grounded to the chassis of the outdoor unit only). All wiring must comply with applicable local and national codes.



# FOUR-WAY CEILING-CASSETTE INDOOR UNITS

MULTI F  
MULTI F MAX

## Dimensions

Figure 185: KNUDB181A Dimensions.

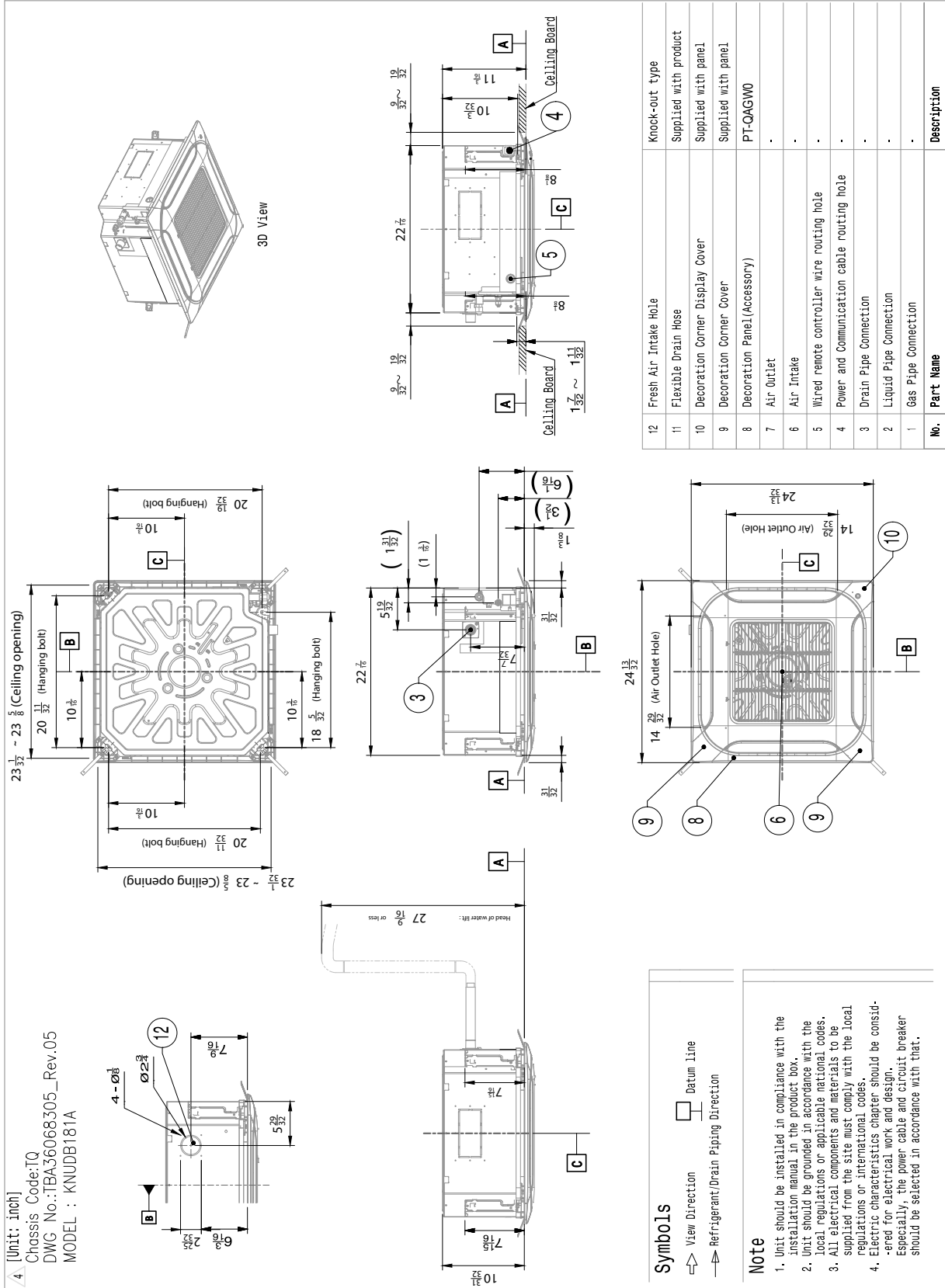


Table 83: Multi F Four-Way Ceiling-Cassette Indoor Units Cooling Capacity Table.

Model No. / Nominal Capacity of Indoor Unit (Btu/h)	Outdoor Air Temp. (°F DB)	Indoor Air Temp. °F DB / °F WB											
		68 / 57		73 / 61		77 / 64		80 / 67		86 / 72		90 / 75	
		TC	SHC	TC	SHC	TC	SHC	TC	SHC	TC	SHC	TC	SHC
KNMDB071A 7,000	14	6.86	4.87	7.29	5.15	7.71	4.99	8.02	5.09	8.57	5.13	8.99	5.23
	20	6.86	4.91	7.28	5.19	7.71	5.02	8.02	5.13	8.56	5.17	8.99	5.27
	25	6.85	4.95	7.28	5.23	7.70	5.06	8.01	5.17	8.55	5.21	8.98	5.31
	30	6.85	4.99	7.27	5.27	7.70	5.10	8.00	5.21	8.55	5.25	8.97	5.35
	35	6.84	5.03	7.27	5.31	7.69	5.14	8.00	5.25	8.54	5.29	8.97	5.39
	40	6.84	5.06	7.26	5.35	7.68	5.18	7.99	5.29	8.53	5.33	8.96	5.43
	45	6.83	5.10	7.25	5.39	7.68	5.22	7.99	5.33	8.53	5.37	8.95	5.47
	50	6.83	5.14	7.25	5.43	7.67	5.26	7.98	5.37	8.52	5.41	8.94	5.52
	55	6.82	5.18	7.24	5.47	7.67	5.30	7.97	5.41	8.51	5.45	8.94	5.56
	60	6.81	5.21	7.24	5.51	7.66	5.33	7.97	5.45	8.51	5.49	8.93	5.60
	65	6.81	5.25	7.23	5.55	7.66	5.37	7.96	5.49	8.50	5.53	8.92	5.64
	70	6.80	5.29	7.23	5.59	7.65	5.41	7.95	5.52	8.49	5.57	8.92	5.68
	75	6.84	5.20	7.06	5.50	7.48	5.33	7.79	5.45	8.33	5.50	8.75	5.61
	80	6.48	5.11	6.90	5.42	7.32	5.26	7.62	5.38	8.16	5.43	8.58	5.55
	85	6.31	5.02	6.73	5.33	7.15	5.17	7.46	5.30	7.99	5.36	8.41	5.48
	90	6.15	4.93	6.57	5.23	6.99	5.09	7.29	5.21	7.83	5.29	8.24	5.40
	95	5.98	4.87	6.39	5.19	6.81	5.05	<b>7.00</b>	<b>5.10</b>	7.64	5.26	8.06	5.38
	100	5.83	4.74	6.25	5.05	6.66	4.93	6.91	5.02	7.50	5.14	7.91	5.27
105	5.69	4.61	6.10	4.92	6.52	4.81	6.82	4.94	7.35	5.03	7.77	5.16	
110	5.54	4.46	5.96	4.76	6.37	4.66	6.67	4.79	7.21	4.89	7.62	5.02	
115	5.39	4.32	5.81	4.63	6.23	4.54	6.53	4.67	7.06	4.77	7.48	4.90	
118	5.31	4.29	5.72	4.60	6.14	4.52	6.44	4.65	6.97	4.76	7.39	4.89	
122	5.28	4.28	5.69	4.59	6.11	4.51	6.41	4.64	6.94	4.75	7.36	4.89	
KNUDB091A 9,000	14	8.82	6.31	9.37	6.66	9.92	6.45	10.31	6.59	11.01	6.64	11.56	6.77
	20	8.82	6.36	9.36	6.72	9.91	6.50	10.31	6.64	11.01	6.70	11.55	6.82
	25	8.81	6.41	9.36	6.77	9.90	6.55	10.30	6.69	11.00	6.75	11.54	6.87
	30	8.80	6.46	9.35	6.82	9.90	6.60	10.29	6.74	10.99	6.80	11.54	6.93
	35	8.80	6.50	9.34	6.87	9.89	6.65	10.28	6.79	10.98	6.85	11.53	6.98
	40	8.79	6.55	9.33	6.92	9.88	6.70	10.27	6.84	10.97	6.90	11.52	7.03
	45	8.78	6.60	9.33	6.97	9.87	6.75	10.27	6.90	10.96	6.95	11.51	7.09
	50	8.78	6.65	9.32	7.03	9.87	6.80	10.26	6.95	10.96	7.00	11.50	7.14
	55	8.77	6.70	9.31	7.08	9.86	6.85	10.25	7.00	10.95	7.06	11.49	7.19
	60	8.76	6.75	9.31	7.13	9.85	6.90	10.24	7.05	10.94	7.11	11.48	7.24
	65	8.76	6.80	9.30	7.18	9.84	6.95	10.24	7.10	10.93	7.16	11.47	7.29
	70	8.75	6.85	9.29	7.23	9.84	7.00	10.23	7.15	10.92	7.21	11.47	7.35
	75	8.54	6.73	9.08	7.12	9.62	6.90	10.01	7.05	10.71	7.12	11.25	7.26
	80	8.33	6.62	8.87	7.01	9.41	6.80	9.80	6.96	10.49	7.03	11.03	7.18
	85	8.12	6.50	8.66	6.89	9.20	6.70	9.59	6.85	10.28	6.94	10.82	7.09
	90	7.91	6.37	8.45	6.77	8.99	6.59	9.37	6.75	10.06	6.84	10.60	6.99
	95	7.68	6.31	8.22	6.71	8.75	6.54	<b>9.00</b>	<b>6.60</b>	9.83	6.80	10.36	6.96
	100	7.50	6.14	8.03	6.54	8.57	6.38	8.88	6.50	9.64	6.66	10.17	6.82
105	7.31	5.97	7.84	6.37	8.38	6.23	8.77	6.40	9.45	6.51	9.99	6.68	
110	7.12	5.77	7.66	6.17	8.19	6.03	8.58	6.20	9.26	6.33	9.80	6.50	
115	6.94	5.59	7.47	5.99	8.01	5.87	8.39	6.05	9.08	6.18	9.61	6.35	
118	6.82	5.55	7.36	5.96	7.89	5.84	8.28	6.02	8.96	6.15	9.50	6.33	
122	6.79	5.54	7.32	5.94	7.86	5.83	8.24	6.01	8.93	6.15	9.46	6.32	

TC = Total Capacity (kBtu/h).

SHC: Sensible Heat Capacity (kBtu/h).

Nominal capacity as rated 0 ft. above sea level and a 0 ft. level difference between outdoor and indoor units. Corresponding refrigerant piping length is accordance with standard length of each outdoor unit.

Nominal cooling capacity rating obtained with air entering the indoor unit at 80°F dry bulb (DB) and 67°F wet bulb (WB), and outdoor ambient conditions of 95°F dry bulb (DB) and 75°F wet bulb (WB).

The shaded table columns and rows indicate reference data. When operating at this temperature, these values can be different if the system is not running consistently.

Four-Way Ceiling-Cassette

# FOUR-WAY CEILING CASSETTE INDOOR UNITS

MULTI F  
MULTI F MAX

## Cooling Capacity Table

Table 84: Multi F Four-Way Ceiling-Cassette Indoor Units Cooling Capacity Table.

Model No. / Nominal Capacity of Indoor Unit (Btu/h)	Outdoor Air Temp. (°F DB)	Indoor Air Temp. °F DB / °F WB											
		68 / 57		73 / 61		77 / 64		80 / 67		86 / 72		90 / 75	
		TC	SHC	TC	SHC	TC	SHC	TC	SHC	TC	SHC	TC	SHC
KNUDB121A 12,000	14	11.76	8.51	12.49	8.99	13.22	8.70	13.75	8.88	14.69	8.96	15.42	9.13
	20	11.75	8.57	12.48	9.06	13.21	8.77	13.74	8.95	14.67	9.03	15.40	9.20
	25	11.75	8.64	12.48	9.13	13.20	8.84	13.73	9.02	14.66	9.10	15.39	9.27
	30	11.74	8.71	12.47	9.20	13.19	8.90	13.72	9.09	14.65	9.17	15.38	9.34
	35	11.73	8.77	12.46	9.27	13.18	8.97	13.71	9.16	14.64	9.24	15.37	9.41
	40	11.72	8.84	12.45	9.34	13.17	9.04	13.70	9.23	14.63	9.31	15.36	9.48
	45	11.71	8.90	12.44	9.41	13.16	9.11	13.69	9.30	14.62	9.38	15.35	9.55
	50	11.70	8.97	12.43	9.47	13.15	9.17	13.68	9.37	14.61	9.45	15.33	9.62
	55	11.69	9.03	12.42	9.54	13.14	9.24	13.67	9.44	14.60	9.52	15.32	9.70
	60	11.68	9.10	12.41	9.61	13.13	9.31	13.66	9.50	14.59	9.58	15.31	9.77
	65	11.67	9.17	12.40	9.68	13.12	9.38	13.65	9.57	14.57	9.65	15.30	9.84
	70	11.66	9.23	12.39	9.75	13.11	9.44	13.64	9.64	14.56	9.72	15.29	9.91
	75	11.38	9.08	12.11	9.60	12.83	9.31	13.35	9.51	14.27	9.60	15.00	9.79
	80	11.10	8.92	11.82	9.45	12.55	9.17	13.07	9.38	13.99	9.48	14.71	9.68
	85	10.83	8.76	11.54	9.29	12.26	9.03	12.78	9.24	13.70	9.36	14.42	9.56
	90	10.55	8.60	11.26	9.13	11.98	8.88	12.50	9.10	13.42	9.22	14.13	9.43
	95	10.25	8.51	10.96	9.05	11.67	8.82	12.00	8.90	13.10	9.18	13.81	9.39
	100	10.00	8.28	10.71	8.82	11.42	8.61	11.84	8.76	12.85	8.98	13.56	9.20
105	9.75	8.05	10.46	8.59	11.17	8.40	11.69	8.62	12.60	8.78	13.31	9.01	
110	9.50	7.77	10.21	8.31	10.92	8.14	11.44	8.37	12.35	8.53	13.07	8.76	
115	9.25	7.54	9.96	8.08	10.67	7.92	11.19	8.15	12.10	8.33	12.82	8.56	
118	9.10	7.49	9.81	8.03	10.52	7.88	11.04	8.12	11.95	8.30	12.67	8.54	
122	9.05	7.47	9.76	8.01	10.48	7.87	10.99	8.11	11.90	8.29	12.62	8.53	
KNUDB181A 18,000	14	17.65	12.33	18.74	13.02	19.84	12.61	20.63	12.88	22.03	12.98	23.12	13.23
	20	17.63	12.43	18.73	13.13	19.82	12.71	20.61	12.98	22.01	13.09	23.11	13.33
	25	17.62	12.52	18.71	13.23	19.81	12.81	20.60	13.08	22.00	13.19	23.09	13.44
	30	17.60	12.62	18.70	13.33	19.79	12.91	20.58	13.18	21.98	13.29	23.07	13.54
	35	17.59	12.71	18.68	13.43	19.78	13.00	20.57	13.28	21.96	13.39	23.05	13.64
	40	17.58	12.81	18.67	13.53	19.76	13.10	20.55	13.38	21.94	13.49	23.04	13.75
	45	17.56	12.90	18.66	13.63	19.75	13.20	20.53	13.48	21.93	13.59	23.02	13.85
	50	17.55	13.00	18.64	13.73	19.73	13.30	20.52	13.58	21.91	13.69	23.00	13.95
	55	17.54	13.10	18.63	13.83	19.72	13.39	20.50	13.68	21.89	13.79	22.98	14.05
	60	17.52	13.19	18.61	13.93	19.70	13.49	20.49	13.78	21.88	13.89	22.97	14.16
	65	17.51	13.29	18.60	14.03	19.69	13.59	20.47	13.87	21.86	13.99	22.95	14.26
	70	17.50	13.38	18.58	14.13	19.67	13.69	20.46	13.97	21.84	14.09	22.93	14.36
	75	17.08	13.16	18.16	13.92	19.24	13.49	20.03	13.79	21.41	13.92	22.50	14.20
	80	16.66	12.93	17.74	13.70	18.82	13.30	19.60	13.60	20.98	13.75	22.06	14.03
	85	16.24	12.70	17.32	13.47	18.40	13.09	19.17	13.40	20.55	13.56	21.63	13.85
	90	15.82	12.46	16.90	13.23	17.97	12.88	18.75	13.19	20.12	13.37	21.20	13.67
	95	15.37	12.33	16.44	13.12	17.51	12.78	18.00	12.90	19.65	13.30	20.72	13.61
	100	14.99	12.00	16.06	12.78	17.13	12.47	17.77	12.70	19.28	13.01	20.35	13.33
105	14.62	11.67	15.69	12.45	16.76	12.17	17.53	12.50	18.90	12.73	19.97	13.05	
110	14.24	11.27	15.32	12.05	16.39	11.79	17.16	12.13	18.53	12.36	19.60	12.70	
115	13.87	10.93	14.94	11.71	16.01	11.48	16.79	11.82	18.15	12.07	19.22	12.41	
118	13.65	10.85	14.72	11.64	15.79	11.42	16.56	11.77	17.93	12.03	19.00	12.37	
122	13.57	10.83	14.64	11.62	15.71	11.40	16.49	11.75	17.85	12.01	18.92	12.36	

TC = Total Capacity (kBtu/h).

SHC: Sensible Heat Capacity (kBtu/h).

Nominal capacity as rated 0 ft. above sea level and a 0 ft. level difference between outdoor and indoor units. Corresponding refrigerant piping length is accordance with standard length of each outdoor unit.

Nominal cooling capacity rating obtained with air entering the indoor unit at 80°F dry bulb (DB) and 67°F wet bulb (WB), and outdoor ambient conditions of 95°F dry bulb (DB) and 75°F wet bulb (WB).

The shaded table columns and rows indicate reference data. When operating at this temperature, these values can be different if the system is not running consistently.

Multi F and Multi F MAX Indoor Unit Engineering Manual

Table 85: Multi F Four-Way Ceiling-Cassette Indoor Units Heating Capacity Table.

Model No. / Nominal Capacity of Indoor Unit (Btu/h)	Outdoor Air Temp.		Indoor Air Temp. °F DB					
	°F DB	°F WB	61	64	68	70	72	75
			TC	TC	TC	TC	TC	TC
KNMDB071A 7,000	0	-0.4	4.17	4.11	4.07	4.05	3.99	3.82
	5	4.5	4.70	4.64	4.60	4.58	4.52	4.34
	10	9	5.22	5.17	5.13	5.11	5.05	4.87
	17	15	5.93	5.87	5.83	<b>5.81</b>	5.75	5.56
	20	19	6.19	6.13	6.09	6.08	6.02	5.81
	25	23	6.63	6.57	6.53	6.52	6.46	6.22
	30	28	7.01	6.96	6.92	6.90	6.84	6.63
	35	32	7.40	7.34	7.30	7.28	7.22	7.04
	40	36	7.74	7.68	7.64	7.62	7.56	7.39
	45	41	8.08	8.02	7.98	7.96	7.90	7.73
	47	43	8.22	8.16	8.12	<b>8.10</b>	8.04	7.87
	50	46	8.35	8.29	8.25	8.23	8.17	7.98
	55	51	8.57	8.51	8.47	8.45	8.39	8.16
	60	56	8.57	8.51	8.47	8.45	8.39	8.20
	63	59	8.57	8.51	8.47	8.45	8.39	8.22
68	64	8.57	8.51	8.47	8.45	8.39	8.25	
KNUDB091A 9,000	0	-0.4	5.35	5.28	5.23	5.20	5.12	4.90
	5	4.5	6.03	5.95	5.90	5.88	5.80	5.58
	10	9	6.71	6.63	6.58	6.56	6.48	6.26
	17	15	7.61	7.54	7.49	<b>7.46</b>	7.39	7.14
	20	19	7.95	7.88	7.83	7.80	7.72	7.46
	25	23	8.52	8.44	8.39	8.37	8.29	7.99
	30	28	9.01	8.93	8.88	8.86	8.78	8.52
	35	32	9.50	9.42	9.37	9.34	9.27	9.04
	40	36	9.94	9.86	9.81	9.78	9.71	9.48
	45	41	10.37	10.30	10.25	10.22	10.15	9.92
	47	43	10.55	10.48	10.43	<b>10.40</b>	10.32	10.10
	50	46	10.72	10.64	10.59	10.57	10.49	10.24
	55	51	11.00	10.93	10.88	10.85	10.78	10.48
	60	56	11.00	10.93	10.88	10.85	10.78	10.52
	63	59	11.00	10.93	10.88	10.85	10.78	10.55
68	64	11.00	10.93	10.88	10.85	10.78	10.60	

TC = Total Capacity (kBtu/h).

Nominal capacity as rated 0 ft. above sea level and a 0 ft. level difference between outdoor and indoor units. Corresponding refrigerant piping length is accordance with standard length of each outdoor unit. Nominal heating capacity rating obtained with air entering the indoor unit at 70°F dry bulb (DB) and 60°F wet bulb (WB), and outdoor ambient conditions of 47°F dry bulb (DB) and 43°F wet bulb (WB).

Four-Way Ceiling-Cassette

# FOUR-WAY CEILING-CASSETTE INDOOR UNITS

MULTI F  
MULTI F MAX

## Heating Capacity Table

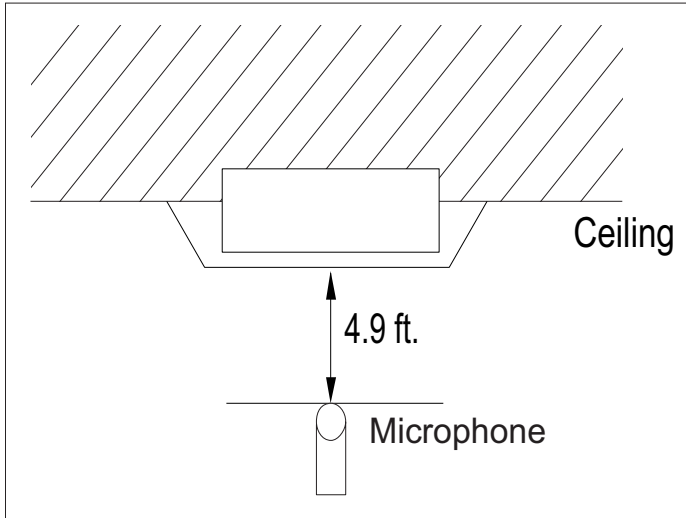
Table 86: Multi F Four-Way Ceiling-Cassette Indoor Units Heating Capacity Table.

Model No. / Nominal Capacity of Indoor Unit (Btu/h)	Outdoor Air Temp.		Indoor Air Temp. °F DB					
	°F DB	°F WB	61	64	68	70	72	75
			TC	TC	TC	TC	TC	TC
KNUDB121A 12,000	0	-0.4	7.10	7.00	6.93	6.90	6.80	6.50
	5	4.5	8.00	7.90	7.83	7.80	7.70	7.40
	10	9	8.90	8.80	8.73	8.70	8.60	8.30
	17	15	10.10	10.00	9.93	<b>9.90</b>	9.80	9.48
	20	19	10.55	10.45	10.38	10.35	10.25	9.90
	25	23	11.30	11.20	11.13	11.10	11.00	10.60
	30	28	11.95	11.85	11.78	11.75	11.65	11.30
	35	32	12.60	12.50	12.43	12.40	12.30	12.00
	40	36	13.18	13.08	13.02	12.98	12.88	12.58
	45	41	13.77	13.67	13.60	13.57	13.47	13.17
	47	43	14.00	13.90	13.83	<b>13.80</b>	13.70	13.40
	50	46	14.23	14.13	14.06	14.03	13.93	13.59
	55	51	14.60	14.50	14.43	14.40	14.30	13.90
	60	56	14.60	14.50	14.43	14.40	14.30	13.96
	63	59	14.60	14.50	14.43	14.40	14.30	14.00
	68	64	14.60	14.50	14.43	14.40	14.30	14.06
KNUDB181A 18,000	0	-0.4	10.70	10.55	10.45	10.40	10.25	9.80
	5	4.5	12.06	11.91	11.81	11.76	11.61	11.15
	10	9	13.41	13.26	13.16	13.11	12.96	12.51
	17	15	15.22	15.07	14.97	<b>14.92</b>	14.77	14.29
	20	19	15.90	15.75	15.65	15.60	15.45	14.92
	25	23	17.03	16.88	16.78	16.73	16.58	15.98
	30	28	18.01	17.86	17.76	17.71	17.56	17.03
	35	32	18.99	18.84	18.74	18.69	18.54	18.09
	40	36	19.87	19.72	19.62	19.57	19.42	18.97
	45	41	20.75	20.60	20.50	20.45	20.30	19.85
	47	43	21.10	20.95	20.85	<b>20.80</b>	20.65	20.20
	50	46	21.44	21.29	21.19	21.14	20.99	20.48
	55	51	22.01	21.86	21.75	21.70	21.55	20.95
	60	56	22.01	21.86	21.75	21.70	21.55	21.04
	63	59	22.01	21.86	21.75	21.70	21.55	21.10
	68	64	22.01	21.86	21.75	21.70	21.55	21.20

TC = Total Capacity (kBtu/h).

Nominal capacity as rated 0 ft. above sea level and a 0 ft. level difference between outdoor and indoor units. Corresponding refrigerant piping length is accordance with standard length of each outdoor unit. Nominal heating capacity rating obtained with air entering the indoor unit at 70°F dry bulb (DB) and 60°F wet bulb (WB), and outdoor ambient conditions of 47°F dry bulb (DB) and 43°F wet bulb (WB).

Figure 186: Sound Pressure Level Measurement Location.

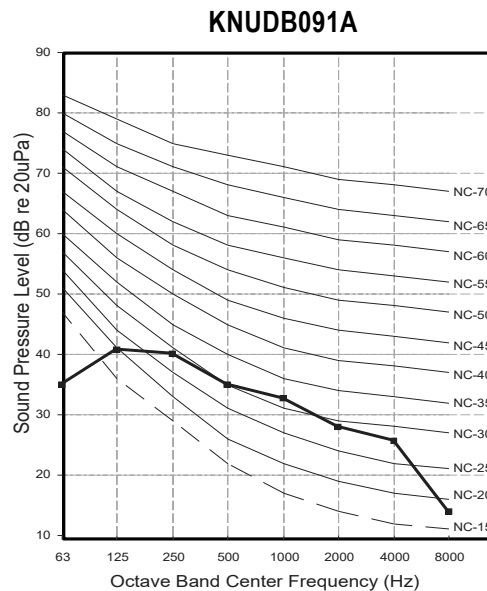
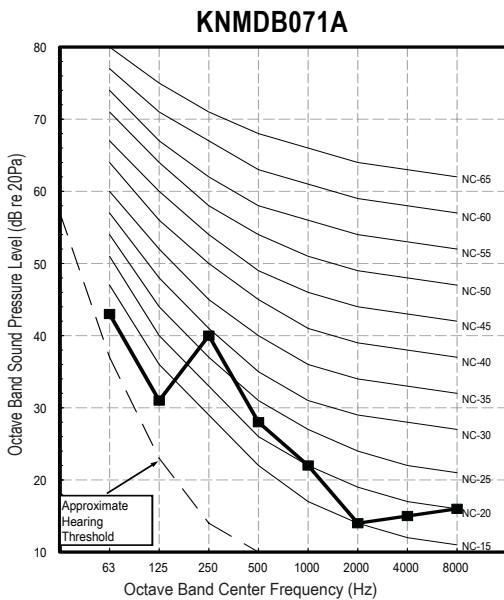


- Measurement taken 4.9' away from the unit.
- Measurements taken with no attenuation and units operating at full load normal operating condition.
- Sound level will vary depending on a range of factors such as construction (acoustic absorption coefficient) of particular area in which the equipment is installed.
- Sound power levels are measured in dB(A).
- Tested in anechoic chamber per ISO Standard 3745.

Table 87: Sound Pressure Levels (dB[A]).

Model No.	Sound Pressure Levels (dB[A]) (Cooling and Heating)		
	High Fan Speed	Medium Fan Speed	Low Fan Speed
KNMDB071A	31	27	24
KNUDB091A	36	33	30
KNMDB121A	38	35	32
KNUDB181A	41	39	36

Figure 187: KNMDB071A and KNUDB091A Sound Pressure Level Diagrams.

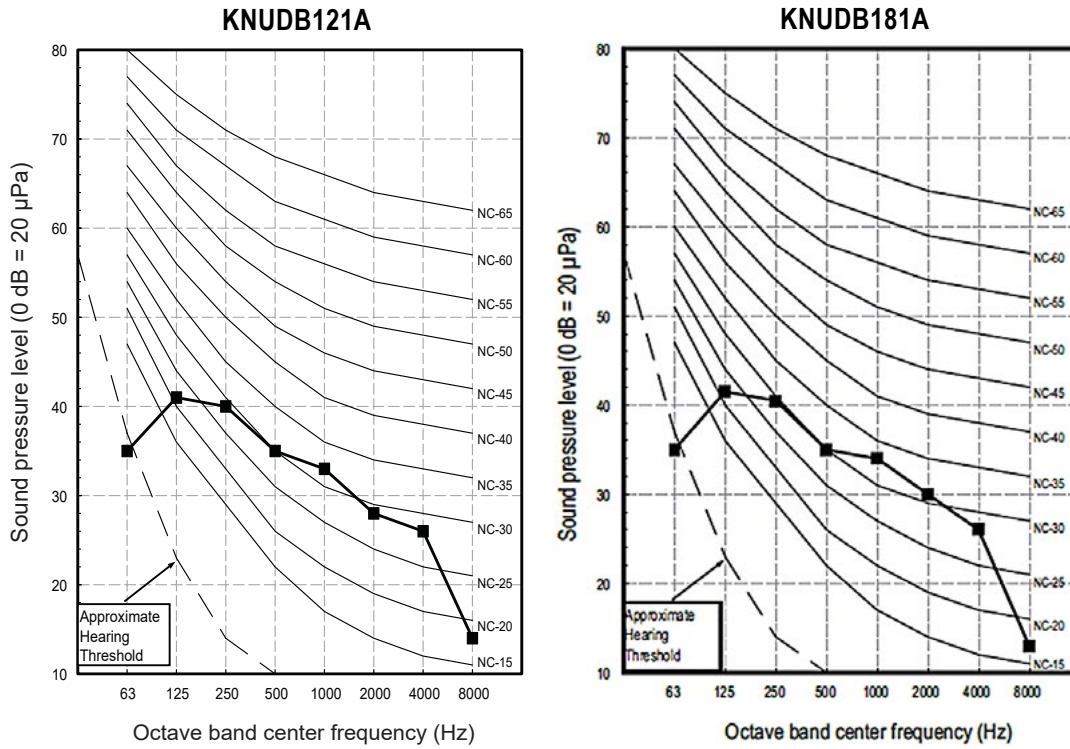


# FOUR-WAY CEILING CASSETTE INDOOR UNITS

Acoustic Data

MULTI F  
MULTI F MAX

Figure 188: KNUDB121A and KNUDB181A Sound Pressure Level Diagrams.



Multi F and Multi F MAX Indoor Unit Engineering Manual

Figure 189: KNMDB071A Air Velocity and Temperature Distribution Charts.

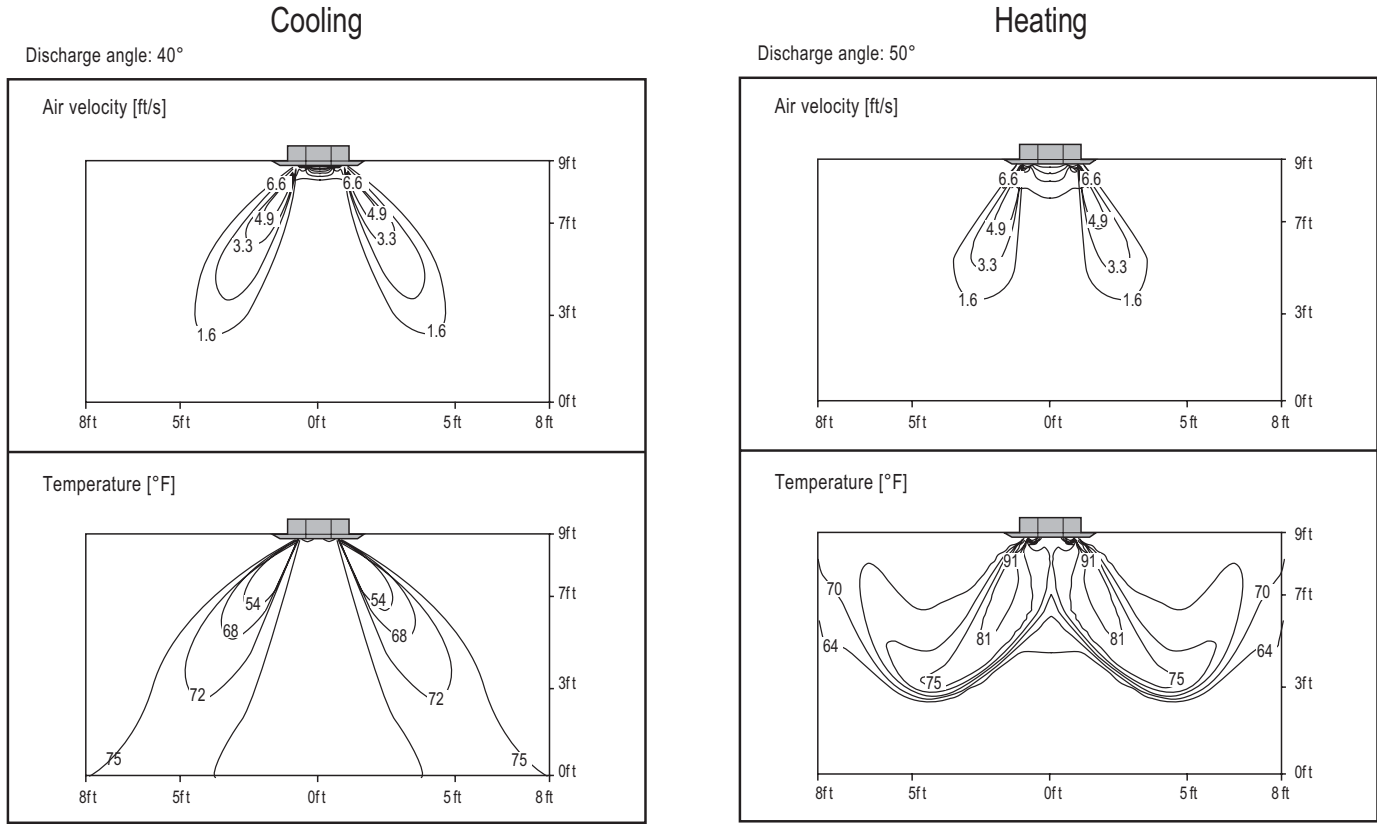
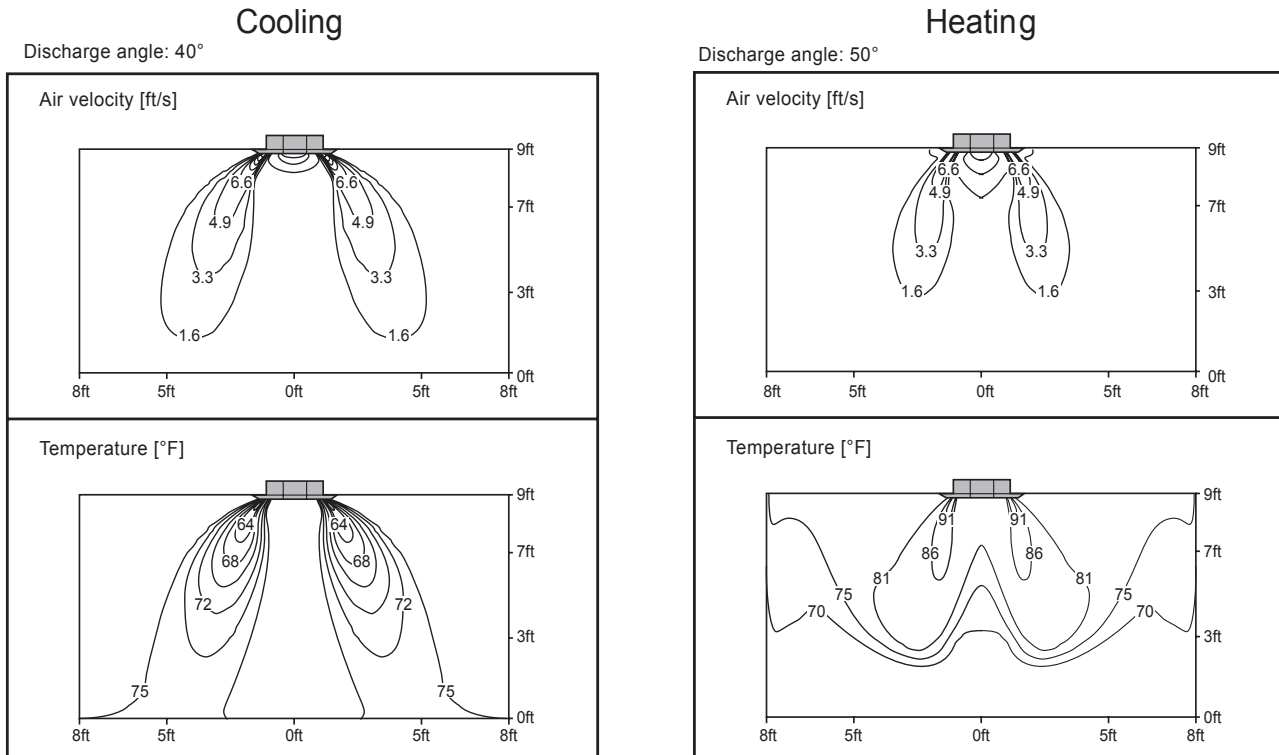


Figure 190: KNUDB091A Air Velocity and Temperature Distribution Charts.



# FOUR-WAY CEILING CASSETTE INDOOR UNITS

MULTI F  
MULTI F MAX

## Air Velocity and Temperature Distribution

Figure 191: KNUDB121A Air Velocity and Temperature Distribution Charts.

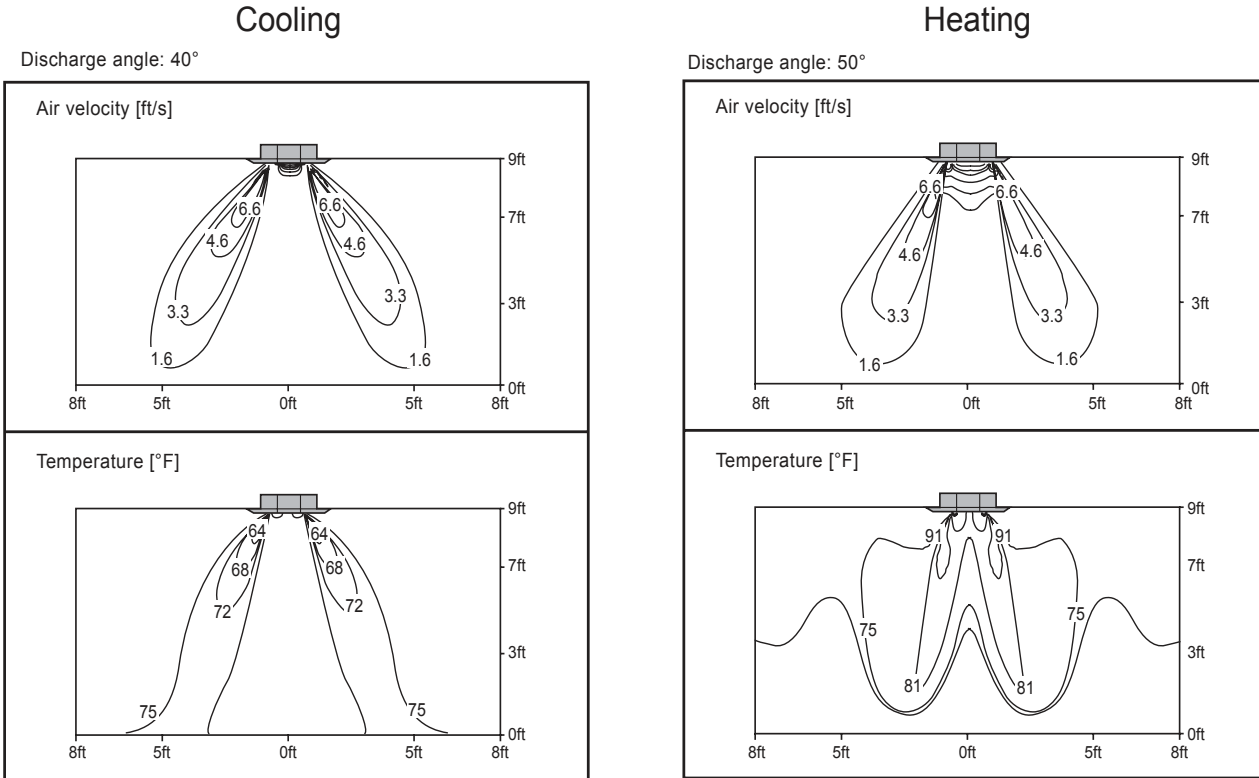
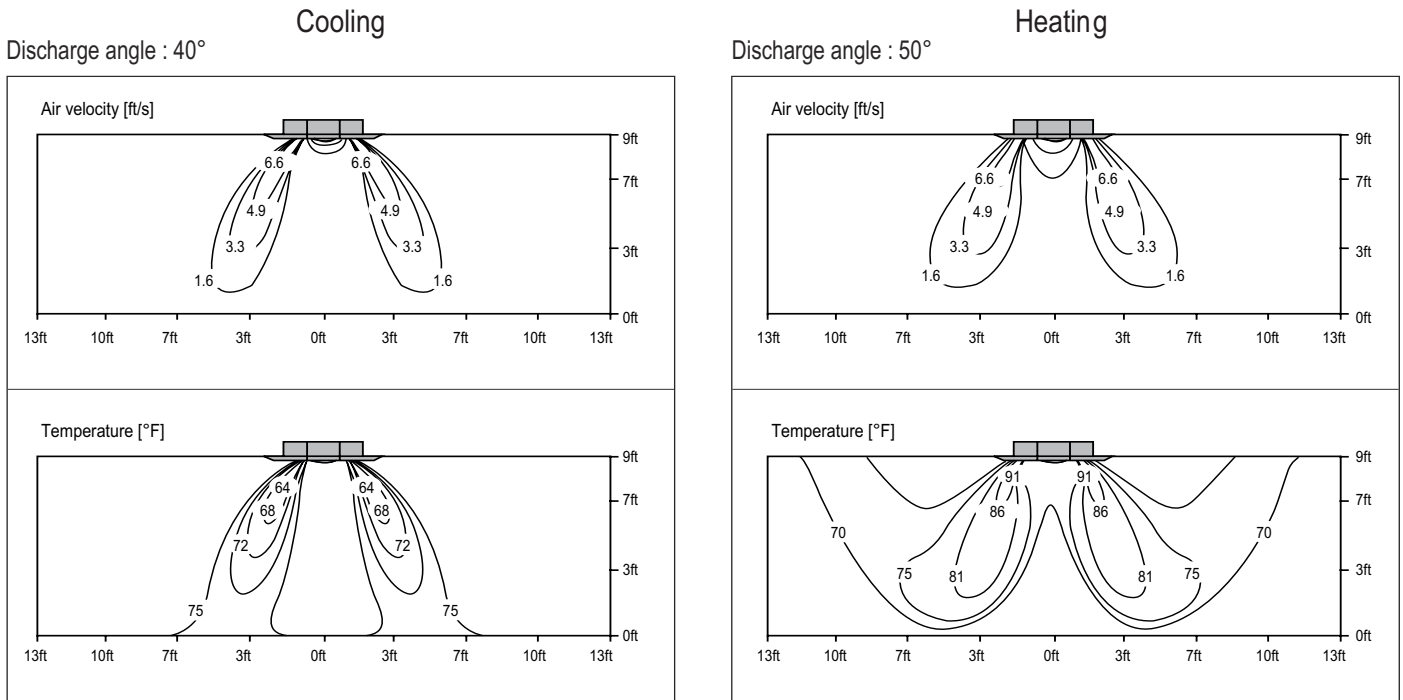
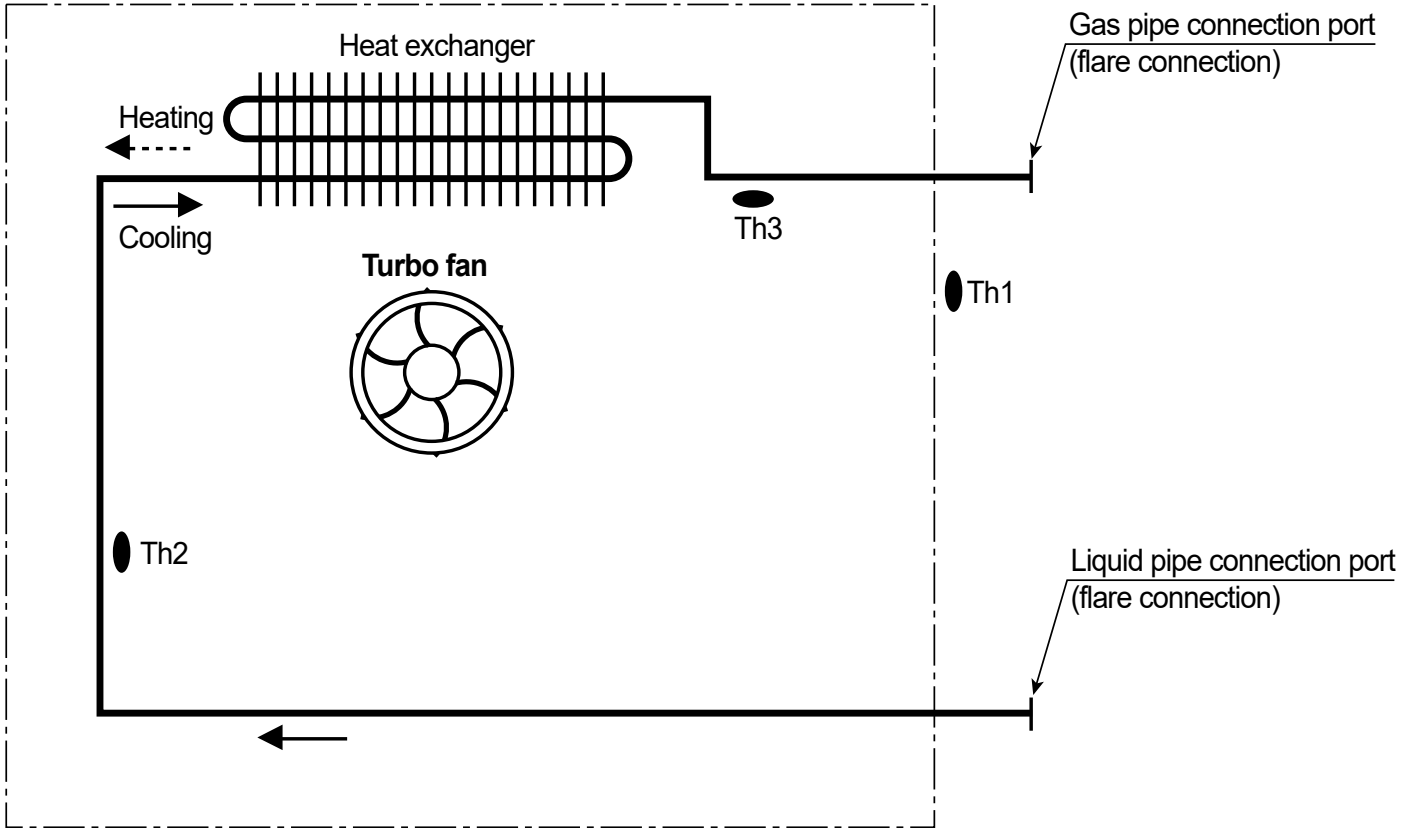


Figure 192: KNUDB181A Air Velocity and Temperature Distribution Charts.



Multi F and Multi F MAX Indoor Unit Engineering Manual

Figure 193: Multi F Four-Way Ceiling-Cassette Indoor Unit Refrigerant Flow Diagram.



Four-Way Ceiling-Cassette

Table 88: Multi F Four-Way Ceiling-Cassette Indoor Unit Refrigerant Pipe Sizes.

Model No.	Vapor (inch)	Liquid (inch)
KNMDB071A	Ø3/8	Ø1/4
KNUDB091A		
KNUDB121A		
KNUDB181A	Ø1/2	

Table 89: Multi F Four-Way Ceiling-Cassette Indoor Unit Refrigerant Pipe Connections.

Model No.	Vapor (inch)	Liquid (inch)
KNMDB071A	Ø3/8	Ø1/4
KNUDB091A		
KNUDB121A		
KNUDB181A	Ø1/2	

Table 90: Multi F Four-Way Ceiling-Cassette Indoor Unit Thermistor Details.

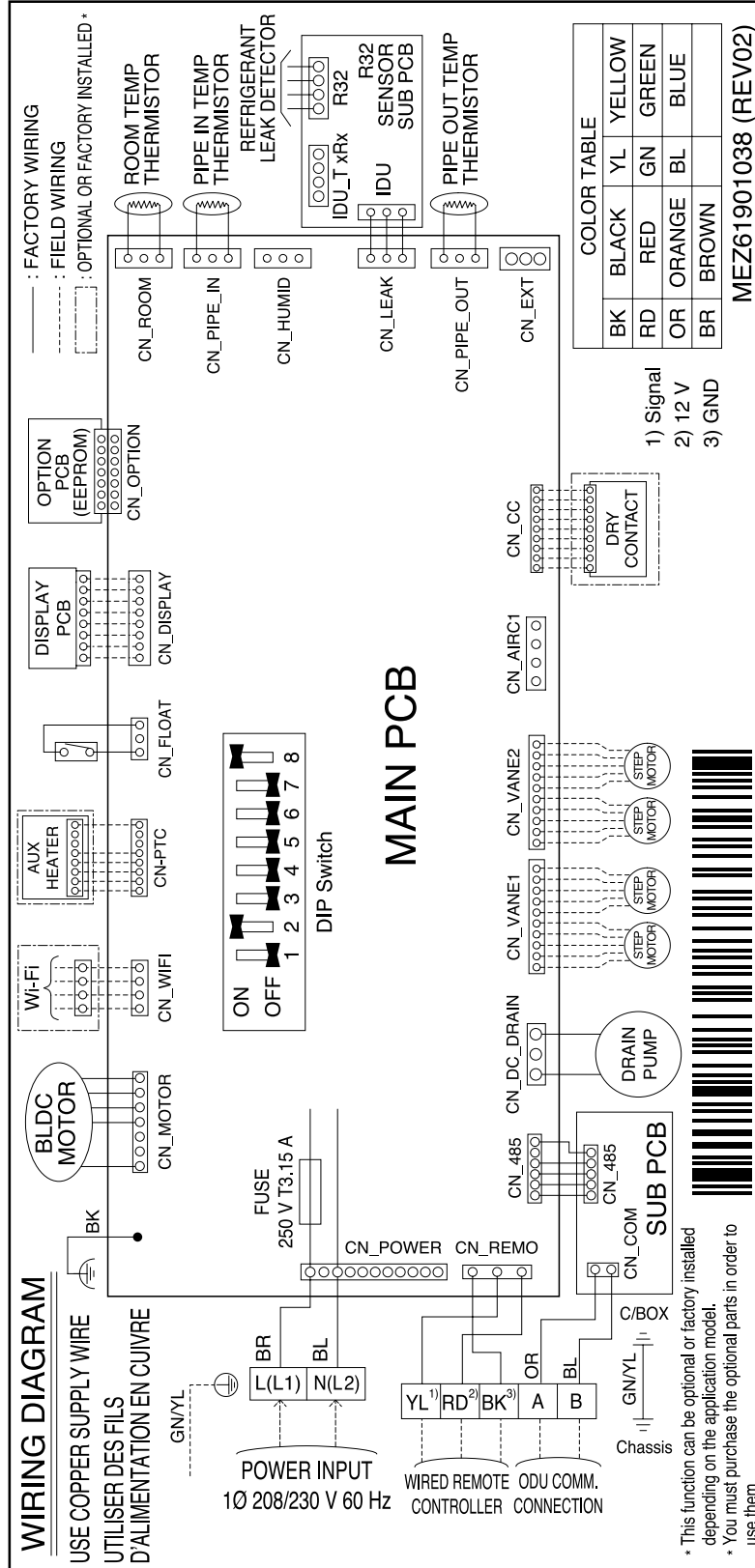
Location	Description	PCB Connector
Th1	Thermistor for suction air temperature	CN_ROOM
Th2	Thermistor for evaporator inlet temperature	CN_PIPE/IN
Th3	Thermistor for evaporator outlet temperature	CN_PIPE/OUT

# FOUR-WAY CEILING CASSETTE INDOOR UNITS

## Wiring Diagram

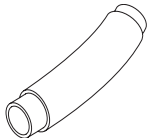
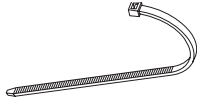
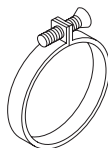
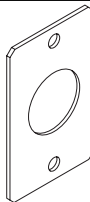
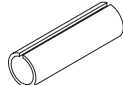

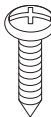
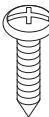
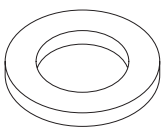

MULTI F  
MULTI F MAX

Figure 194: Multi F Four-Way Ceiling-Cassette Indoor Unit Wiring Diagram.



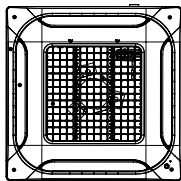
## Factory Supplied Parts

Table 91: Parts Table.

Part	Quantity	Image	Part	Quantity	Image
Drain Hose	One (1)		Zip Ties	Four (4)	
Metal Clamp	Two (2)		Conduit Bracket	One (1)	
Insulation for Fittings	One (1) Set	 For Vapor Piping  For Liquid Piping	M4 Screws	Two (2)	 
Washer for Hanging Bracket	Eight (8)		Wireless Handheld Controller with Holder (PWLSSB21H)	One (1)	

Four-Way Ceiling-Cassette

Table 92: Required Accessory Table.

Part	Quantity	Image
Grille Kit (PT-QAGW0)	One (1)	

## Factory Supplied Materials

- Installation Guide (template)
- Owner's Manual
- Installation Manual

### **⚠ WARNING**

Installation work must be performed by trained personnel and in accordance with national wiring standards and all local or other applicable codes. Improper installation can result in fire, electric shock, physical injury, or death.

### **NOTICE**

Read all instructions before installing this product. Become familiar with the unit's components and connections, and the order of installation. Incorrect installation can degrade or prevent proper operation.

## Required Tools

- Level
- Screwdriver
- Electric drill
- Hole core drill
- Flaring tool set
- Torque wrenches
- Hexagonal wrench
- Gas-leak detector
- Thermometer

# FOUR-WAY CEILING CASSETTE INDOOR UNITS

## Installation and Best Layout Practices

MULTI F  
MULTI F MAX

### Selecting the Best Location

#### Do's

- Place the unit where air circulation will not be blocked.
- Place the unit where drainage can be obtained easily.
- Place the unit where noise prevention is taken into consideration.
- Ensure there is sufficient strength to bear the load of the indoor unit.
- Ensure there is sufficient maintenance space.
- Locate the indoor unit in a location that is level, and where it can be easily connected to the outdoor unit / branch distribution unit.

#### Don'ts

- Do not install the unit near a heat or steam source, or where considerable amounts of oil, iron powder, or flour are used.
- Do not install the unit where sulfuric acid and flammable or corrosive gases are generated, vented into, or stored.
- Do not install the unit near high-frequency generators.
- Do not install the unit near a doorway.

The unit will be damaged, will malfunction, and/or will not operate as designed if installed in any of the conditions listed.

#### NOTICE

- Indoor units (IDUs) must not be placed in an environment where the IDUs will be exposed to harmful volatile organic compounds (VOCs) or in environments where there is improper air make up or supply or inadequate ventilation. If there are concerns about VOCs in the environment where the IDUs are installed, proper air make up or supply and/or adequate ventilation must be provided. Additionally, in buildings where IDUs will be exposed to VOCs, consider a third party factory-applied epoxy coating to the fan coils for each IDU where the entire coil is dipped, not sprayed.
- If the unit is installed near a body of water, the installation parts are at risk of corroding. Appropriate anti-corrosion methods must be taken for the unit and all installation parts.

### Installing in a High or Dropped Ceiling

High or dropped ceilings, often found in commercial buildings and offices, will cause a wide temperature differentiation. To countermeasure:

- Change the indoor unit mode selection to allow for higher ceilings (see table).
- Install an air circulator.
- Set the air discharge outlet so that heated air flows in a downward direction.
- Use a dual door system to protect the building gate or exit.

### Installing in an Area Exposed to Unconditioned Air

In some installation applications, areas (floors, walls) in some rooms will be exposed to unconditioned air (room will be above or next to an unheated garage or storeroom). To countermeasure:

- Verify that carpet is or will be installed (carpet will increase the temperature by three (3) degrees).
- Add insulation between the floor joists.
- Install radiant heat or another type of heating system to the floor.

### Installing in an Area with High Humidity Levels

If the environment is prone to humidity levels of 80% or more (near the ocean, lakes, etc.) or where steam could collect in the plenum:

- Install additional insulation to the indoor unit (glass wool insulation >13/32 inches thick).
- Install additional insulation to the refrigerant piping (insulation >13/16 inches thick).
- Seal all gaps between the indoor unit and the ceiling tiles (make the area air tight) so that humidity does not transfer from the plenum to the conditioned space. Also, add a ceiling grille for ventilation.

Figure 195: Indoor Unit Clearance Requirements.

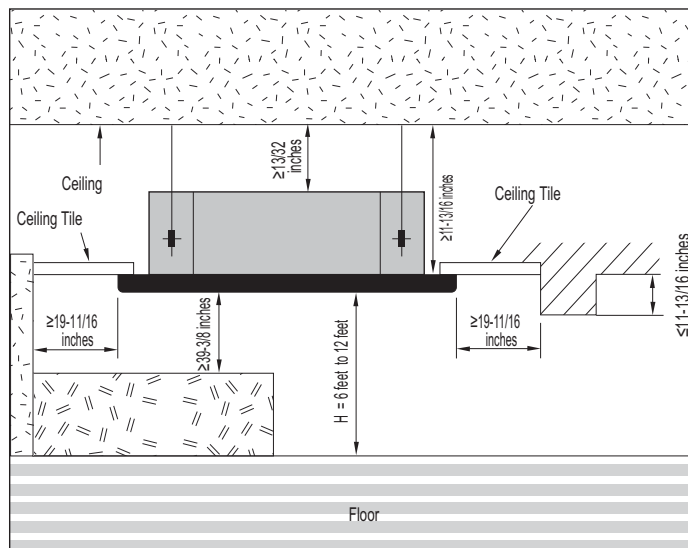
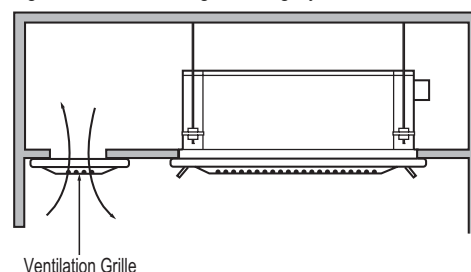


Table 93: Indoor Unit High Ceiling Mode Selection Options.

Ceiling Height	Mode Selection
≤7-1/2 feet	Low Ceiling
7-1/2 feet to 8-7/8 feet	Standard
8-7/8 feet to 10-3/16 feet	High Ceiling
10-3/16 feet to 11-13/16 feet	Very High Ceiling

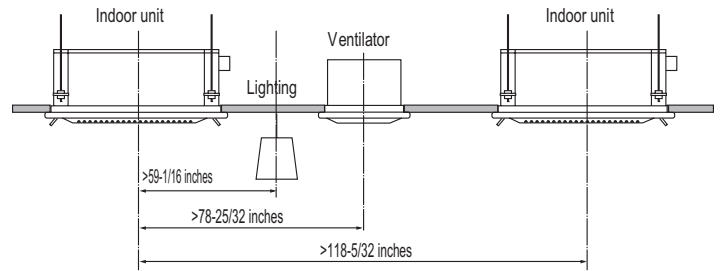
Figure 196: Installing in a Highly Humid Location.



### Installing Multiple Indoor Units in One Area

Ensure there is enough space between indoor units, lighting fixtures, and ventilation fans / systems.

Figure 197: Installing Multiple Indoor Units.

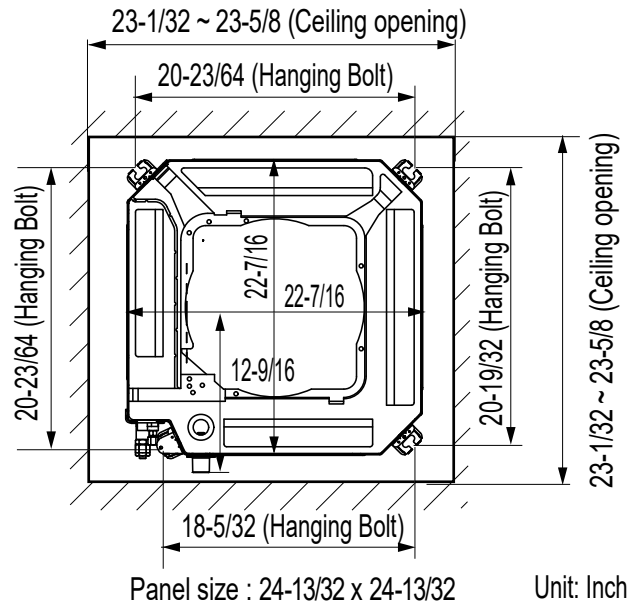


## Preparing the Installation Area and Hanging the Indoor Unit Frame

### Preparing the Installation Area

1. Installation guide (template) depicts the exact dimensions necessary for the ceiling opening.
2. Choose the location for the indoor unit, and then mark where the bolts, refrigerant piping, and drain hose must be. Suspension bolt angle must account for drain direction.
3. Drill holes for the bolts. Use either a W 3/8 inch or a M10 size bolt.

Figure 198: Ceiling Opening Dimensions and Bolt Locations.



### NOTICE

For easier installation, attach the accessories (except for the decoration panel) before hanging the indoor unit.

Figure 199: Installing the Hanging Bolt in the Ceiling.

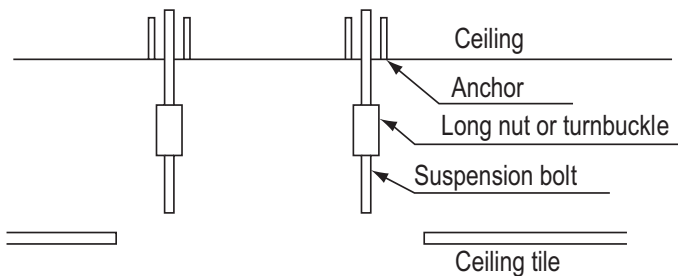
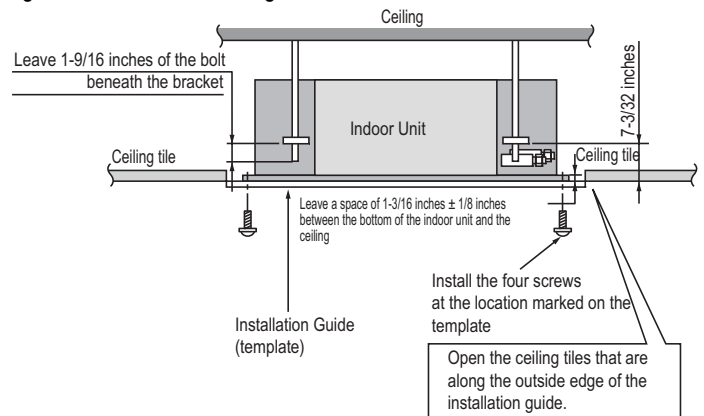


Figure 200: Installation Diagram.



# FOUR-WAY CEILING CASSETTE INDOOR UNITS

## Installation and Best Layout Practices

MULTI F  
MULTI F MAX

### For New Ceilings

1. Use a sunken insert, a sunken anchor, or any other field-supplied part to reinforce the ceiling so that it can bear the weight of the indoor unit. Use a temporary washer plate to more easily set up the unit suspension location.
2. Ceiling height is shown on the side of the installation guide (template). Adjust the height of the unit accordingly. Adjust the clearance before hanging the indoor unit.
3. Refer to the installation guide (template) for the dimensions to the ceiling opening. Match the center of the indoor unit (labeled) to the center indicated on the installation guide.
4. Align the installation guide (template) with the label attached to the unit (affixing the template to the unit if desired) to properly place the unit.
5. Remove the temporary washer plate and position the indoor unit hanger brackets on the bolts. Secure with nuts and washers on the top and bottom of the hanger brackets.
6. Ceiling-cassette indoor units are equipped with a built-in drain pump and float switch, therefore, the unit must be installed horizontally or condensate will drip out and cause product malfunction. Measure the unit at each corner to verify that it is level.
7. Remove the installation guide (template).

### For Existing Ceilings

1. Use anchors when installing the indoor unit in an existing ceiling.
2. Ceiling height is shown on the side of the installation guide (template). Adjust the height of the unit accordingly. Adjust the clearance before hanging the indoor unit.
3. Remove the temporary washer plate and position the indoor unit hanger brackets on the bolts. Secure with nuts and washers on the top and bottom of the hanger brackets.
4. Ceiling-cassette indoor units are equipped with a built-in drain pump and float switch, therefore, the unit must be installed horizontally or condensate will drip out and cause product malfunction. Measure the unit at each corner to verify that it is level.
5. Remove the installation guide (template).

### Installing the Drain System

- Drain piping must have downward gradient of at least 1/50 to 1/100; to prevent reverse flow, slope must not be straight up and down.
- Do not damage the drain port on the indoor unit when connecting the field-supplied drain piping.
- Drain piping specifications:
  - Indoor Unit Drain Connection: 1-1/4 inch outside diameter.
  - Field-Supplied Drain Piping: Polyvinyl chloride piping with 1-inch inside diameter and pipe fittings.

### Checking the Drain Pump

The unit uses a drain pump to remove condensate. The pump must be tested before the system operates.

- Connect flexible drain hose to the field-installed drain piping; leave it as is until the test is complete.
- Pour water into the flexible drain hose and check for leaks.
- After power wiring installation is complete, operate the drain pump to see if it sounds and functions properly.
- After the test is complete, connect the flexible drain hose to the indoor unit drain port.

Figure 201: Hanging the Indoor Unit.

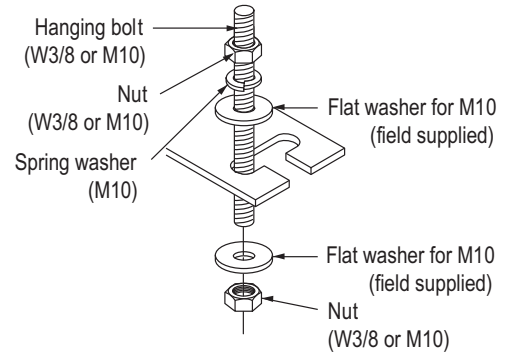


Figure 202: Indoor Unit Drain Piping.

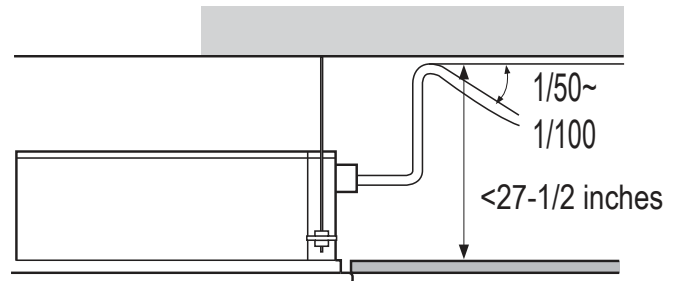
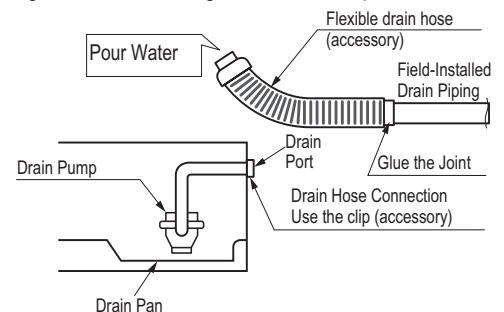


Figure 203: Checking the Drain Pump.



### Insulating the Refrigerant and Drain Piping

#### **⚠ WARNING**

Ensure all piping is insulated. Exposed piping can cause burns if touched.

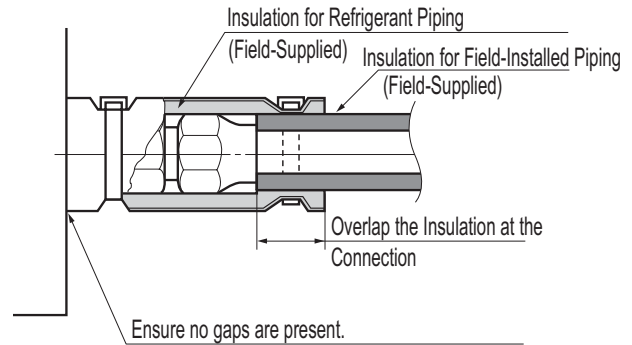
#### Refrigerant Piping Insulation

Field-installed vapor and liquid refrigerant piping lines must be properly and completely covered in insulation (up to the indoor unit piping connections). Any exposed piping will generate condensate or will cause burns if touched. Insulation for this field-installed refrigerant piping must have a minimum heat resistance of 248°F.

#### Drain Piping Insulation

Drain piping must have insulation a minimum of 7/32 inches thick.

Figure 204: Insulating the Piping.



#### Installing the Insulation

1. Overlap the insulation at the connection of the field-installed piping and the indoor unit piping. Tape together so that no gaps exist.
2. Secure insulation to the rear piping housing section with vinyl tape.
3. Bundle the piping and drain hose with tape where they meet at the back of the indoor unit frame. Position the drain hose at the bottom of the bundle (positioning the drain hose at the top of the bundle will cause the drain pan to overflow inside the indoor unit).

### Power Wiring / Communications Cable Guidelines

- Follow manufacturer's circuit diagrams in the technical manuals.
- Confirm power source specifications.
- Confirm that the electrical capacity is sufficient.
- Starting current must be maintained  $\pm 10$  percent of the rated current marked on the outdoor unit name plate.
- Confirm cable thickness specifications.
- It is required that a circuit breaker is installed, especially if conditions could become wet or moist.
- Include a disconnect in the power wiring system, add an air gap contact separation of at least 1/8 inch in each active (phase) conductor.

#### **⚠ WARNING**

Loose wiring will cause unit to malfunction, overheat, and catch fire, resulting in severe injury or death.

#### **NOTICE**

- Terminal screws will become loose during transport. Properly tighten the terminal connections during installation.
- A voltage drop will cause the following problems:
- Magnetic switch vibration, fuse breaks, or disturbance to the normal function of an overload protection device.
  - Compressor will not receive the proper starting current.

# FOUR-WAY CEILING CASSETTE INDOOR UNITS

## Installation and Best Layout Practices

MULTI F  
MULTI F MAX

### Connecting the Power Wiring and Communications Cable

1. To access the terminal block, open the control box cover.
2. Insert the power wiring / communications cable from the outdoor unit or branch distribution unit (Multi F MAX systems only) through the sides of the indoor unit and control box. Pass the wiring through the designated access holes to prevent damage. To prevent electromagnetic interference and product malfunction, leave a space between the power wiring and communications cable outside of the indoor unit.
3. Connect each wire to its appropriate terminal on the indoor unit control board. Verify that the color and terminal numbers from the outdoor unit or branch distribution unit (Multi F MAX systems only) wiring match the color and terminal numbers on the indoor unit.
4. Neatly arrange power wiring / communications cable and secure with the appropriate cable restraint. ⚠ When clamping, ⚠ do not apply force to the wiring connections.
5. Firmly reattach the control box cover. ⚠ Do not catch the wiring in the electric box cover and make sure the cover firmly closes.
6. Fill in any gaps around the wiring access holes with sealant to prevent foreign particles from entering the indoor unit.

Figure 205: Power Wiring and Communications Cable Connection Access.

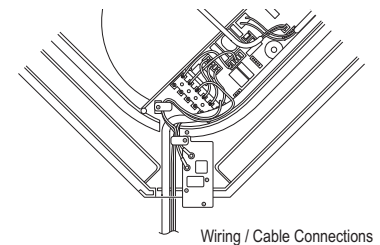
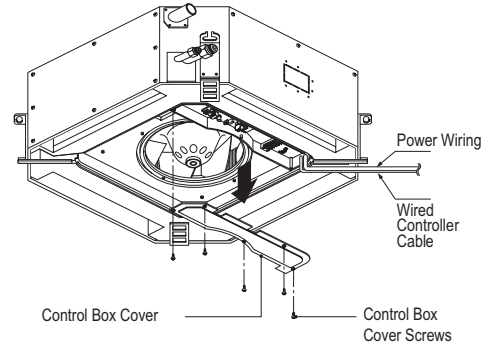


Figure 206: Simplified View of Indoor Unit to Outdoor Unit / Branch Distribution Unit Terminal Connections.

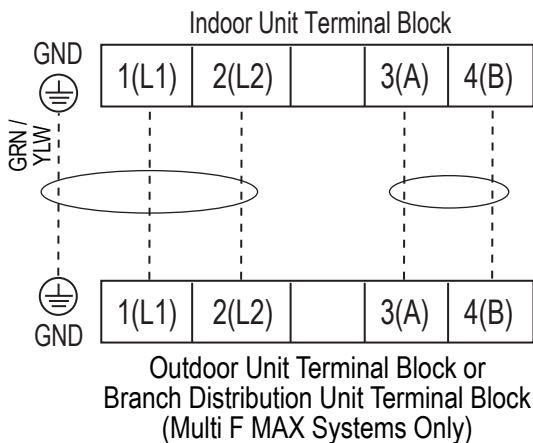
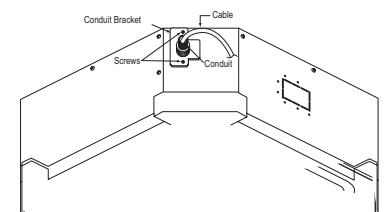
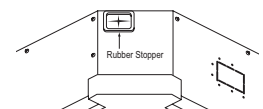


Figure 207: Using a Conduit.



### Using a Conduit

1. Remove the rubber stopper on the indoor unit. Pass the power wiring / communications cable through the conduit, the conduit mounting plate, and to / through the control panel of the indoor unit.
2. Tighten the conduit and the conduit mounting plate together.
3. Connect the power wiring / communications cable to the indoor unit terminal block.
4. Screw the conduit mounting plate to the indoor unit.

### Controller Options

Four-way ceiling-concealed indoor units include a wireless handheld controller (AKB75735428), but optional LG-supplied wired controllers are available.

#### Wireless Handheld Controller

Figure 208: AKB75735428 Wireless Handheld Controller.

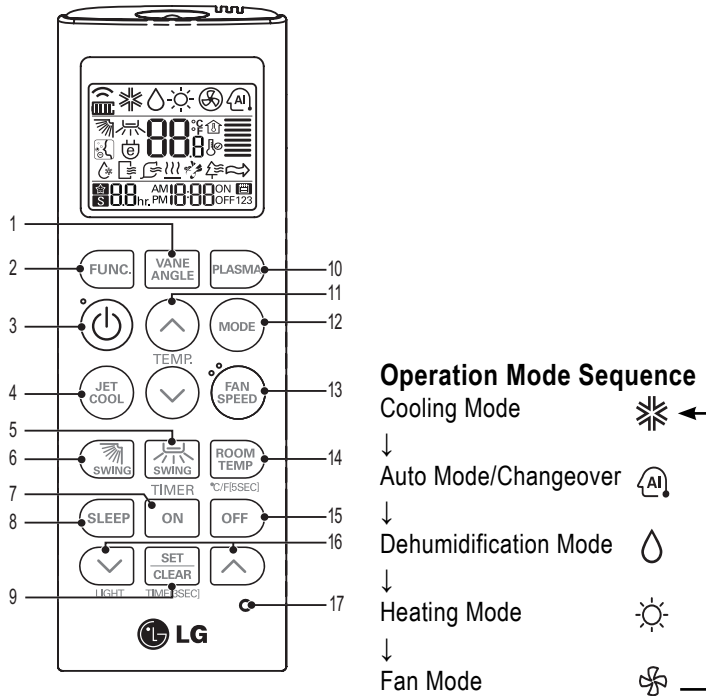


Table 94: AKB75735428 Wireless Handheld Controller Functions.<sup>1</sup>

Button Label	Description
1	Vane Angle Button: Sets the angle to each vane.
2	Function Setting Button: Sets or clears auto clean, smart clean, electric heater, or individual vane angle control functions.
3	On / Off Button: Turns the power on/off.
4	Jet Cool: Sets the unit to super high fan speed when in cooling mode.
5	Left / Right Air Flow Button (optional): Sets the desired left / right (horizontal) air flow direction.
6	Up / Down Air flow Button: Stops or starts louver movement, and sets the desired air flow direction to up or down.
7	On Time Button: Sets the time when the operation begins.
8	Sleep Timer Button: Sets the sleep mode operation.
9	Set / Clear Button: Sets or cancels the timer, also sets the current time.
10	Plasma Button: Starts or stops plasma-purification functions.
11	Room Temperature Setting Button: Raises or lowers temperature setpoint in cooling and heating operation.
12	Operation mode selection button: Selects the operation mode.
13	Indoor Fan Speed Button: Changes the fan speed to one of four choices: low, medium, high, and chaos.
14	Room Temperature Check Button: Displays / checks the room temperature.
15	Off Timer button: Sets the time when the operation ends.
16	Time Setting (Up / Down) / Light Button: Sets the timer and adjusts the brightness of the LED.
17	Reset Button: Resets the remote controller.

<sup>1</sup>Depending on the indoor unit model, some functions will not be supported or displayed.

#### Wired Controller Connections

Controllers can connect to the indoor unit in one of two different ways.

1. LG Wired Remote Extension Cable with Molex plug (PZC-WRC1; sold separately) that connects to the CN-REMO terminal on the indoor unit PCB.
2. Field-supplied controller cable that connects to the indoor unit terminal block (must be at least UL2547 or UL1007, 22 AWG, two-core, one-shield core, at least FT-6 rated if local electric and building codes require plenum cable usage).

#### NOTICE

When using field-supplied controller cable, make sure to connect the yellow to yellow (communications wire), red to red (12V power wire), and black to black (ground wire) terminals from the remote controller to the indoor unit terminal blocks.

Figure 209: PZC-WRC1 LG Wired Remote Extension Cable.

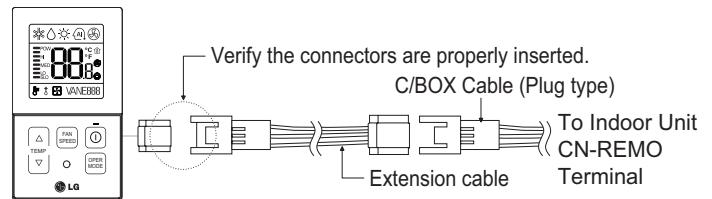
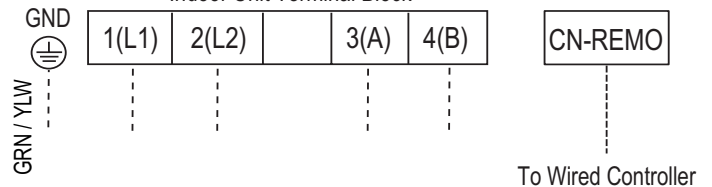


Figure 210: Wired Controller Connections on the Indoor Unit Terminal Block.



# FOUR-WAY CEILING CASSETTE INDOOR UNITS

## Installation and Best Layout Practices

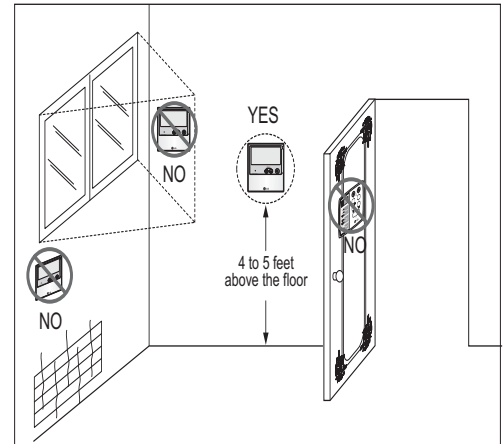
MULTI F  
MULTI F MAX

### Wired Controller Placement

Wall indoor units can be used with various wired controllers (optional; sold separately). Wired controllers include a sensor to detect room temperature. To maintain comfort levels in the conditioned space, the wired controller must be installed in a location away from direct sunlight, high humidity, and where it could be directly exposed to cold air. Controller must be installed four (4) to five (5) feet above the floor where its display can be read easily, in an area with good air circulation, and where it can detect an average room temperature.

- ⊘ Do not install the remote controller where it can be impacted by the following:
- Drafts or dead spots behind doors and in corners
  - Hot or cold air from ducts
  - Radiant heat from sun or appliances
  - Concealed pipes and chimneys
  - Uncontrolled areas such as an outside wall behind the remote controller

Figure 211: Proper Location for the Wired Controller.



### Hanging the Wired Controller

1. The controller wiring / cable can be installed in one of three directions: top, back, or on the right side. If top or right side installation is desired, remove cable guide grooves on the controller, and then position wiring / cable on applicable side.
2. Choose and mark the area of installation, and then screw the wall plate into place (using the provided parts). Install the controller wall plate to fit the electrical box if one is present. Ensure that no gaps exist between the wall plate and the wall itself.
3. Arrange wiring / cables so as not to interfere with the controller circuitry. Position the wired controller on the wall plate. Snap into place by pressing the bottom part of the wired controller onto the wall plate. Make sure that no gaps exist between the wired controller and the wall plate on all sides.
4. To remove wired controller from the wall plate, insert a screwdriver into the two holes at the bottom. Twist screwdriver to release controller. ⊘ Do not damage the controller components when removing.

Figure 212: Removing the Cable Guide Grooves.

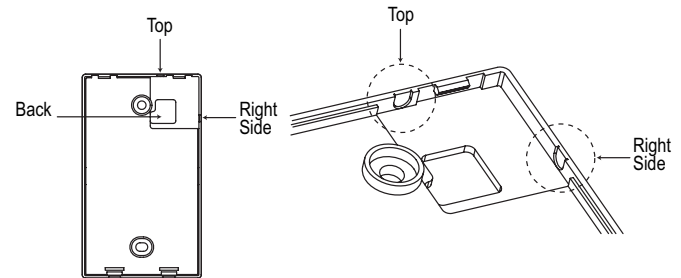


Figure 213: Attaching the Wall Plate.

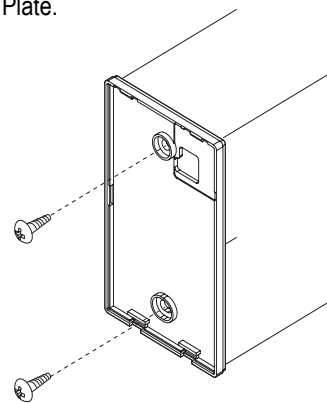
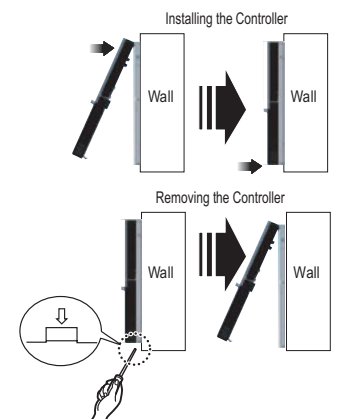


Figure 214: Installing / Removing the Controller.



### Assigning the Thermistor for Temperature Detection

Each indoor unit includes a return air thermistor assigned to sense the temperature. If a wired controller is installed, there is a choice of sensing temperature with either the indoor unit return air thermistor or the thermistor in the wired controller. It is also an option to set both thermistors to sense temperature so that indoor unit bases its operation on the first thermistor to reach the designated temperature differential. For applicable indoor units, an optional Remote Temperature Sensor can be used in lieu of the return air thermistor—either alone or in conjunction with a wired controller thermistor as previously described.

# ONE-WAY CEILING-CASSETTE INDOOR UNIT DATA

**Mechanical Specifications on page 166**

**General Data / Specifications on page 167**

**Dimensions on page 168**

**Cooling Capacity Table on page 169**

**Heating Capacity Table on page 171**

**Acoustic Data on page 173**

**Air Velocity and Temperature Distribution on page 175**

**Refrigerant Flow Diagram on page 177**

**Wiring Diagram on page 178**

**Factory Supplied Parts and Materials on page 179**

**Installation and Best Layout Practices on page 180**

# ONE-WAY CEILING CASSETTE INDOOR UNITS

MULTI F  
MULTI F MAX

## Mechanical Specifications and Features

### One-way Ceiling-Cassette Indoor Units

#### General

All LG indoor units are factory assembled, wired, piped, and provided with a control circuit board, fan, and motor. One-way ceiling-cassette units have a sound rating no higher than 46 dB(A) as tested per KSA0701 ISO Standard 3745.

#### Coil

Indoor unit coils are factory built and are comprised of aluminum fins mechanically bonded to copper tubing. Each unit has a refrigerant coil which has been pressure tested at the factory. Each unit is provided with a factory installed condensate drain pan below the coil.

#### Refrigerant System

System is designed for use with R32 refrigerant. The refrigeration circuit is pressure-tested at the factory and shipped with a holding charge of helium gas. Refrigerant pipe connections are 45° flare, and all refrigerant lines from the outdoor unit to the indoor units must be field insulated.

#### Electrical

Each indoor unit is designed to operate using 208–230/60/1 power with voltage variances of ±10%.

#### Casing

The case is constructed of a galvanized steel plate designed to recess in the ceiling, and has a surface mounted concentric grille on the bottom of the unit. Cold surfaces are covered with a coated polystyrene insulating material. Unit has one supply air outlet and one return air inlet.

#### Fan Assembly and Control

All indoor units have a single, direct-drive cross flow fan. Fans are manufactured of high-strength ABS polymeric resin that is statically and dynamically balanced. The fan motor is brushless digitally controlled (BLDC) with permanently lubricated and sealed ball bearings. The fan / motor assembly is mounted on vibration-attenuating rubber grommets. Fan speed is controlled using a microprocessor-based direct digital control algorithm that provides pre-programmed, field-selectable fixed or auto fan speeds in the Heating and Cooling modes.

The indoor fan has Low, Med, High, Power Cool and Auto settings for Cooling mode; and has Low, Med, High, Power Heat and Auto settings for Heating mode. Auto setting adjusts the fan speed based on the difference between the controller setpoint and space temperature.

#### Air Filter

Return air is filtered with a factory-supplied, removable, washable filter accessible from the bottom of the unit.

#### Architectural Grille

An architectural grille is sold as a separate required accessory. The one-way grille is off-white acrylonitrile butadiene styrene (ABS) polymeric resin with a tapered trim edge and a hinged, spring clip (screw-less) return air filter-grille door.

### Features

- Inverter (Variable speed fan)
- Internal drain pump
- Jet cool/Jet heat
- Control lock function
- Auto operation
- Auto restart operation
- 24-Hour on/off timer
- Two thermistor control
- Required accessory grille (PT-UCA) sold separately
- Group Control
- Wireless LCD remote control included; wired thermostat available (sold separately)
- Built-in Wi-Fi

#### Airflow Guide Vanes

The architectural grille has a single directional slot diffuser with an oscillating motorized guide vane designed to change the angle airflow is discharged.

The discharge range of motion is 40° in an up/down direction with the capability of locking the vanes in a field-adjusted fixed position.

#### Microprocessor Control

The indoor unit is provided with an integrated control panel to communicate with the outdoor unit. All unit operation parameters are stored in non-volatile memory residing on the unit microprocessor. The microprocessor controls space temperature through using the value provided by the temperature sensor and humidity sensor within the indoor unit. The microprocessor control will activate indoor unit operation when the indoor room temperature falls below or rises above a setpoint temperature, at which point, a signal is sent to the outdoor unit to begin the appropriate mode. The microprocessor will also provide self-diagnostics and auto restart functions. A field-supplied three-wire power cable (3 x 14 AWG) and two-wire communications cable (2 x 18 AWG) must be installed to connect the indoor unit(s) to the outdoor unit.

The indoor unit has built-in Wi-Fi and can be controlled with LG's Smart ThinQ app on a smart device. A field-supplied Wi-Fi network and smart device are required. The Smart ThinQ app is free, and is available for Android™ and iOS. (Android is a trademark of Google LLC.)

#### R32 Refrigerant Leak Detector

The indoor unit has a built-in R32 refrigerant leak detection sensor designed to communicate with release mitigation devices and third party alarms, and transmit a system error code upon detection of a refrigerant leak or sensor failure / expiration.

#### Shut-off Valve

LG single-port shutoff valve (PRHPZ010A; sold separately) is available as an accessory.

#### Controls

The accessory grille has a factory-standard, integral infrared sensor designed to communicate with the supplied LG wireless handheld remote controller. An optional wired controller is available as an additional accessory. Communication between the indoor units and the outdoor unit is accomplished through 18 AWG, two-core, stranded and shielded communication cable.

#### Condensate Lift/Pump

The indoor unit is provided with a factory installed and wired internal condensate lift/pump capable of providing a minimum 27.5 inch lift from the bottom surface of the unit. Drain pump has a safety switch to shut off the indoor unit if the condensate rises too high in the drain pan.

Figure 215: Multi F One-way Ceiling-Cassette Indoor Unit.



Table 95: Multi F One-way Ceiling-Cassette Indoor Unit General Data.

Model Name	KNMFB071A	KNUFB091A	KNUFB121A	KNUFB181A
<b>Grille (Sold Separately)</b>	<b>PT-UCA</b>	<b>PT-UCA</b>	<b>PT-UCA</b>	<b>PT-UCA</b>
Nominal Cooling Capacity (Btu/h) <sup>1</sup>	7,000	9,000	12,000	18,000
Nominal Heating Capacity (Btu/h) <sup>1</sup>	8,100	12,000	15,400	20,000
<i>Operating Range</i>				
Cooling (°F WB)	57-77			
Heating (°F DB)	59-81			
Fan				
Type	Cross Flow Fan			
Motor Output (W) x Qty.	30 x 1			
Motor/Drive	Brushless Digitally Controlled / Direct			
Airflow Rate CFM (Max/H/M/L)	325 / 289 / 258 / 226	353 / 325 / 300 / 289	388 / 353 / 325 / 289	512 / 477 / 406 / 335
<i>Unit Data</i>				
Refrigerant Type <sup>2</sup>	R32			
Refrigerant Control	EEV			
Power Supply V, Ø, Hz <sup>3</sup>	208-230, 1, 60			
Rated Amps (A)	0.58			
Sound Pressure Level dB(A) (Max/H/M/L) <sup>4</sup>	33 / 30 / 28 / 25	35 / 33 / 31 / 30	38 / 35 / 33 / 30	46 / 44 / 40 / 35
Body Dimensions (W x H x D, in.)	40-5/32 x 7-3/4 x 13-3/8			
Grille (Sold separately) Dimensions (WxHxD, in.)	50 x 1-3/16 x 16-7/32			
Body Net Weight (lbs.)	30.4			
Grille (Sold separately) Net Weight (lbs.)	10.8			
Body Shipping Weight (lbs.)	37.0			
Grille (Sold separately) Shipping Weight (lbs.)	13.9			
Power Wiring Cable (No. x AWG) <sup>5</sup>	3 x 14			
Communications Wiring Cable (No. x AWG) <sup>5</sup>	2 x 18			
Heat Exchanger (Row x Column x Fin / inch) x Number	(2 x 12 x 20) x 1			
Dehumidification Rate (pts./hr)	1.4	2.4	4.0	4.9
<i>Pipe Size</i>				
Liquid (in.)	1/4			
Vapor (in.)	3/8			1/2
<i>Connection Size</i>				
Liquid (in.)	1/4			
Vapor (in.)	3/8			1/2
Drain O.D. / I.D. (in.)	1-1/4, 31/32			

<sup>1</sup>Nominal capacity is rated 0 ft. above sea level with a 0 ft. level difference between outdoor and indoor units. All capacities are net with a combination ratio between 95 – 105%.

Nominal cooling capacity rating obtained with air entering the indoor unit at 80°F dry bulb (DB) and 67°F wet bulb (WB) and outdoor ambient conditions of 95°F dry bulb (DB) and 75°F wet bulb (WB).  
Nominal heating capacity rating obtained with air entering the indoor unit at 70°F dry bulb (DB) and 60°F wet bulb (WB) and outdoor ambient conditions of 47°F dry bulb (DB) and 43°F wet bulb (WB).

<sup>2</sup>This unit comes with a dry helium charge.

<sup>3</sup>Acceptable operating voltage: 187V-253V.

<sup>4</sup>Sound pressure levels are tested in an anechoic chamber under ISO Standard 3745 and are the same in both cooling and heating mode. These values can increase due to ambient conditions during operation.

<sup>5</sup>The power wiring and the communication wiring from the outdoor unit to the indoor unit, or from the branch distribution unit to the indoor unit is field supplied and must be stranded, shielded or unshielded (if shielded, it must be grounded to the chassis of the outdoor unit only). All wiring must comply with applicable local and national codes.

# ONE-WAY CEILING-CASSETTE INDOOR UNITS

MULTI F  
MULTI F MAX

## Dimensions

Figure 216: KNMFB071A, KNUFB091A, KNUFB121A and KNUFB181A Dimensions.

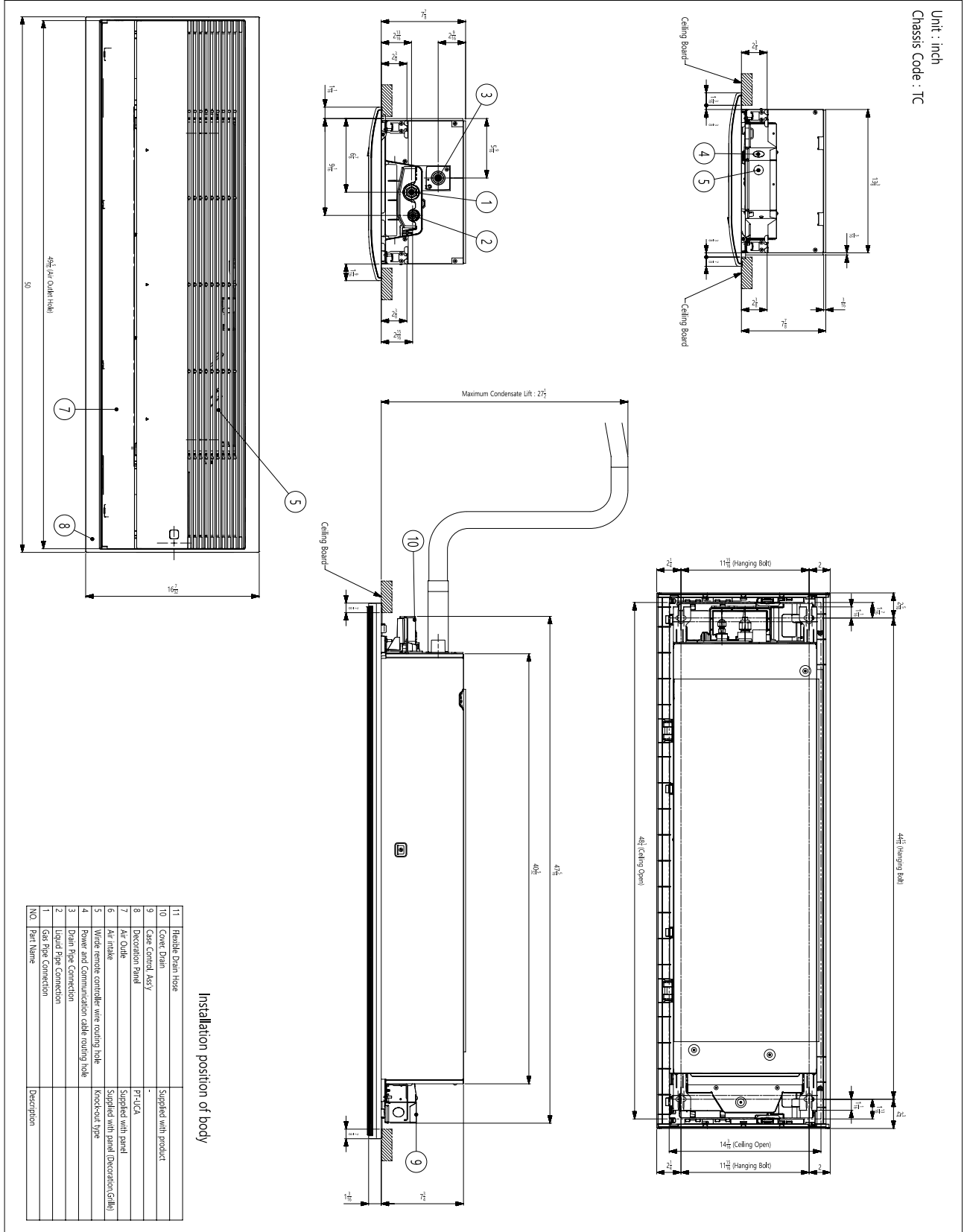


Table 96: Multi F One-way Ceiling-Cassette Indoor Units Cooling Capacity Table.

Model No. / Nominal Capacity of Indoor Unit (Btu/h)	Outdoor Air Temp. (°F DB)	Indoor Air Temp. °F DB / °F WB											
		68 / 57		73 / 61		77 / 64		80 / 67		86 / 72		90 / 75	
		TC	SHC	TC	SHC	TC	SHC	TC	SHC	TC	SHC	TC	SHC
KNMFB071A 7,000	14	6.86	4.68	7.29	4.95	7.71	4.79	8.02	4.89	8.57	4.93	8.99	5.03
	20	6.86	4.72	7.28	4.99	7.71	4.83	8.02	4.93	8.56	4.97	8.99	5.06
	25	6.85	4.76	7.28	5.02	7.70	4.86	8.01	4.97	8.55	5.01	8.98	5.10
	30	6.85	4.79	7.27	5.06	7.70	4.90	8.00	5.01	8.55	5.05	8.97	5.14
	35	6.84	4.83	7.27	5.10	7.69	4.94	8.00	5.04	8.54	5.09	8.97	5.18
	40	6.84	4.87	7.26	5.14	7.68	4.98	7.99	5.08	8.53	5.12	8.96	5.22
	45	6.83	4.90	7.25	5.18	7.68	5.01	7.99	5.12	8.53	5.16	8.95	5.26
	50	6.83	4.94	7.25	5.22	7.67	5.05	7.98	5.16	8.52	5.20	8.94	5.30
	55	6.82	4.97	7.24	5.25	7.67	5.09	7.97	5.19	8.51	5.24	8.94	5.34
	60	6.81	5.01	7.24	5.29	7.66	5.12	7.97	5.23	8.51	5.28	8.93	5.38
	65	6.81	5.05	7.23	5.33	7.66	5.16	7.96	5.27	8.50	5.31	8.92	5.42
	70	6.80	5.08	7.23	5.37	7.65	5.20	7.95	5.31	8.49	5.35	8.92	5.45
	75	6.84	5.00	7.06	5.29	7.48	5.13	7.79	5.24	8.33	5.29	8.75	5.39
	80	6.48	4.91	6.90	5.20	7.32	5.05	7.62	5.16	8.16	5.22	8.58	5.33
	85	6.31	4.82	6.73	5.12	7.15	4.97	7.46	5.09	7.99	5.15	8.41	5.26
	90	6.15	4.73	6.57	5.03	6.99	4.89	7.29	5.01	7.83	5.08	8.24	5.19
	95	5.98	4.68	6.39	4.98	6.81	4.85	<b>7.00</b>	<b>4.90</b>	7.64	5.05	8.06	5.17
	100	5.83	4.56	6.25	4.86	6.66	4.74	6.91	4.82	7.50	4.94	7.91	5.06
105	5.69	4.43	6.10	4.73	6.52	4.62	6.82	4.75	7.35	4.83	7.77	4.96	
110	5.54	4.28	5.96	4.58	6.37	4.48	6.67	4.61	7.21	4.70	7.62	4.82	
115	5.39	4.15	5.81	4.45	6.23	4.36	6.53	4.49	7.06	4.58	7.48	4.71	
118	5.31	4.12	5.72	4.42	6.14	4.34	6.44	4.47	6.97	4.57	7.39	4.70	
122	5.28	4.11	5.69	4.41	6.11	4.33	6.41	4.46	6.94	4.56	7.36	4.70	
KNUFB091A 9,000	14	8.83	7.05	9.37	7.45	9.92	7.22	10.32	7.36	11.02	7.43	11.56	7.57
	20	8.82	7.11	9.37	7.51	9.91	7.27	10.31	7.42	11.01	7.48	11.56	7.63
	25	8.81	7.16	9.36	7.57	9.91	7.33	10.30	7.48	11.00	7.54	11.55	7.69
	30	8.80	7.22	9.35	7.63	9.90	7.39	10.29	7.54	10.99	7.60	11.54	7.75
	35	8.80	7.27	9.34	7.68	9.89	7.44	10.29	7.60	10.98	7.66	11.53	7.81
	40	8.79	7.33	9.34	7.74	9.88	7.49	10.28	7.65	10.97	7.72	11.52	7.87
	45	8.78	7.39	9.33	7.80	9.88	7.55	10.27	7.71	10.97	7.77	11.51	7.92
	50	8.78	7.43	9.32	7.86	9.87	7.61	10.26	7.77	10.96	7.83	11.50	7.98
	55	8.77	7.49	9.32	7.92	9.86	7.66	10.25	7.82	10.95	7.89	11.49	8.04
	60	8.76	7.54	9.31	7.97	9.85	7.72	10.25	7.88	10.94	7.95	11.49	8.10
	65	8.76	7.60	9.30	8.03	9.85	7.77	10.24	7.94	10.93	8.00	11.48	8.16
	70	8.75	7.65	9.29	8.09	9.84	7.83	10.23	7.99	10.92	8.06	11.47	8.22
	75	8.54	7.53	9.08	7.96	9.62	7.72	10.02	7.89	10.71	7.96	11.25	8.12
	80	8.33	7.40	8.87	7.84	9.41	7.60	9.80	7.78	10.49	7.86	11.03	8.03
	85	8.12	7.27	8.66	7.71	9.20	7.49	9.59	7.66	10.28	7.76	10.82	7.93
	90	7.91	7.13	8.45	7.57	8.99	7.37	9.38	7.54	10.06	7.65	10.60	7.82
	95	7.69	7.05	8.22	7.51	8.76	7.31	<b>9.00</b>	<b>7.38</b>	9.83	7.61	10.36	7.78
	100	7.50	6.87	8.03	7.31	8.57	7.13	8.89	7.27	9.64	7.45	10.18	7.63
105	7.31	6.67	7.85	7.12	8.38	6.96	8.77	7.15	9.45	7.28	9.99	7.47	
110	7.12	6.45	7.66	6.89	8.20	6.75	8.58	6.94	9.27	7.07	9.80	7.27	
115	6.94	6.25	7.47	6.70	8.01	6.57	8.40	6.76	9.08	6.90	9.61	7.10	
118	6.83	6.21	7.36	6.66	7.90	6.53	8.28	6.73	8.97	6.88	9.50	7.08	
122	6.79	6.19	7.32	6.65	7.86	6.52	8.25	6.72	8.93	6.87	9.46	7.07	

TC = Total Capacity (kBtu/h).

SHC: Sensible Heat Capacity (kBtu/h).

Nominal capacity as rated 0 ft. above sea level and a 0 ft. level difference between outdoor and indoor units. Corresponding refrigerant piping length is accordance with standard length of each outdoor unit.

Nominal cooling capacity rating obtained with air entering the indoor unit at 80°F dry bulb (DB) and 67°F wet bulb (WB), and outdoor ambient conditions of 95°F dry bulb (DB) and 75°F wet bulb (WB).

The shaded table columns and rows indicate reference data. When operating at this temperature, these values can be different if the system is not running consistently.

# ONE-WAY CEILING CASSETTE INDOOR UNITS

## Cooling Capacity Table

**MULTI F**  
**MULTI F MAX**

Table 97: Multi F One-way Ceiling-Cassette Indoor Units Cooling Capacity Table.

Model No. / Nominal Capacity of Indoor Unit (Btu/h)	Outdoor Air Temp. (°F DB)	Indoor Air Temp. °F DB / °F WB											
		68 / 57		73 / 61		77 / 64		80 / 67		86 / 72		90 / 75	
		TC	SHC	TC	SHC	TC	SHC	TC	SHC	TC	SHC	TC	SHC
KNUFB121A 12,000	14	11.77	9.40	12.49	9.93	13.23	9.62	13.75	9.82	14.69	9.91	15.41	10.10
	20	11.75	9.48	12.49	10.01	13.21	9.69	13.74	9.90	14.67	9.98	15.41	10.17
	25	11.75	9.55	12.47	10.09	13.21	9.77	13.73	9.98	14.67	10.06	15.39	10.25
	30	11.73	9.62	12.47	10.17	13.19	9.85	13.72	10.05	14.65	10.14	15.38	10.33
	35	11.73	9.69	12.45	10.24	13.19	9.92	13.71	10.13	14.64	10.21	15.37	10.41
	40	11.72	9.77	12.45	10.32	13.17	9.99	13.70	10.20	14.63	10.29	15.36	10.49
	45	11.71	9.85	12.44	10.40	13.17	10.07	13.69	10.28	14.62	10.36	15.35	10.56
	50	11.70	9.91	12.43	10.47	13.15	10.15	13.68	10.36	14.61	10.44	15.33	10.64
	55	11.69	9.99	12.42	10.55	13.15	10.22	13.67	10.43	14.59	10.52	15.32	10.72
	60	11.68	10.06	12.41	10.63	13.13	10.29	13.66	10.51	14.59	10.60	15.31	10.79
	65	11.67	10.13	12.40	10.71	13.13	10.36	13.65	10.58	14.57	10.67	15.30	10.88
	70	11.67	10.20	12.39	10.78	13.11	10.44	13.64	10.66	14.56	10.75	15.29	10.96
	75	11.39	10.04	12.11	10.62	12.83	10.29	13.35	10.52	14.27	10.62	15.00	10.83
	80	11.11	9.87	11.83	10.45	12.55	10.14	13.07	10.37	13.99	10.48	14.71	10.70
	85	10.83	9.69	11.55	10.28	12.27	9.99	12.78	10.22	13.70	10.34	14.42	10.57
	90	10.55	9.50	11.27	10.10	11.98	9.83	12.50	10.06	13.41	10.20	14.13	10.43
	95	10.25	9.40	10.96	10.01	11.67	9.75	12.00	9.84	13.10	10.15	13.81	10.38
	100	9.99	9.15	10.71	9.75	11.42	9.51	11.85	9.69	12.85	9.93	13.57	10.17
	105	9.75	8.90	10.46	9.50	11.17	9.29	11.69	9.53	12.60	9.71	13.31	9.96
	110	9.49	8.59	10.21	9.19	10.93	8.99	11.44	9.25	12.35	9.43	13.07	9.69
115	9.25	8.34	9.96	8.94	10.67	8.76	11.19	9.02	12.10	9.21	12.81	9.46	
118	9.10	8.28	9.81	8.88	10.53	8.71	11.04	8.97	11.95	9.18	12.67	9.44	
122	9.05	8.26	9.76	8.86	10.47	8.70	10.99	8.96	11.90	9.16	12.61	9.43	
KNUFB181A 18,000	14	17.65	14.10	18.74	14.90	19.84	14.43	20.63	14.73	22.03	14.86	23.12	15.14
	20	17.63	14.21	18.73	15.02	19.82	14.54	20.61	14.85	22.01	14.97	23.11	15.25
	25	17.62	14.32	18.71	15.13	19.81	14.65	20.60	14.97	22.00	15.09	23.09	15.37
	30	17.60	14.43	18.70	15.25	19.79	14.77	20.58	15.08	21.98	15.21	23.07	15.49
	35	17.59	14.54	18.68	15.36	19.78	14.88	20.57	15.20	21.96	15.32	23.05	15.61
	40	17.58	14.66	18.67	15.48	19.76	14.99	20.55	15.31	21.94	15.44	23.04	15.73
	45	17.56	14.77	18.66	15.60	19.75	15.10	20.53	15.42	21.93	15.55	23.02	15.84
	50	17.55	14.87	18.64	15.71	19.73	15.22	20.52	15.54	21.91	15.67	23.00	15.96
	55	17.54	14.98	18.63	15.83	19.72	15.33	20.50	15.65	21.89	15.78	22.98	16.08
	60	17.52	15.09	18.61	15.94	19.70	15.44	20.49	15.77	21.88	15.90	22.97	16.19
	65	17.51	15.20	18.60	16.06	19.69	15.55	20.47	15.88	21.86	16.01	22.95	16.31
	70	17.50	15.31	18.58	16.17	19.67	15.66	20.46	15.98	21.84	16.13	22.93	16.43
	75	17.08	15.06	18.16	15.93	19.24	15.44	20.03	15.78	21.41	15.93	22.50	16.25
	80	16.66	14.80	17.74	15.68	18.82	15.21	19.60	15.56	20.98	15.72	22.06	16.05
	85	16.24	14.53	17.32	15.42	18.40	14.98	19.17	15.33	20.55	15.51	21.63	15.85
	90	15.82	14.26	16.90	15.14	17.97	14.74	18.75	15.09	20.12	15.30	21.20	15.65
	95	15.37	14.10	16.44	15.01	17.51	14.62	18.00	14.76	19.65	15.22	20.72	15.57
	100	14.99	13.73	16.06	14.63	17.13	14.27	17.77	14.53	19.28	14.89	20.35	15.25
	105	14.62	13.35	15.69	14.25	16.76	13.93	17.53	14.30	18.90	14.56	19.97	14.93
	110	14.24	12.89	15.32	13.79	16.39	13.49	17.16	13.87	18.53	14.15	19.60	14.53
115	13.87	12.51	14.94	13.40	16.01	13.14	16.79	13.52	18.15	13.81	19.22	14.19	
118	13.65	12.42	14.72	13.32	15.79	13.07	16.56	13.46	17.93	13.77	19.00	14.16	
122	13.57	12.39	14.64	13.29	15.71	13.00	16.49	13.40	17.85	13.70	18.92	14.10	

TC = Total Capacity (kBtu/h).

SHC: Sensible Heat Capacity (kBtu/h).

Nominal capacity as rated 0 ft. above sea level and a 0 ft. level difference between outdoor and indoor units. Corresponding refrigerant piping length is accordance with standard length of each outdoor unit.

Nominal cooling capacity rating obtained with air entering the indoor unit at 80°F dry bulb (DB) and 67°F wet bulb (WB), and outdoor ambient conditions of 95°F dry bulb (DB) and 75°F wet bulb (WB).

The shaded table columns and rows indicate reference data. When operating at this temperature, these values can be different if the system is not running consistently.

Multi F and Multi F MAX Indoor Unit Engineering Manual

Table 98: Multi F One-way Ceiling-Cassette Indoor Units Heating Capacity Table.

Model No. / Nominal Capacity of Indoor Unit (Btu/h)	Outdoor Air Temp.		Indoor Air Temp. °F DB					
	°F DB	°F WB	61	64	68	70	72	75
			TC	TC	TC	TC	TC	TC
KNMFB071A 7,000	-13	-13.4	2.78	2.61	2.66	2.67	2.65	2.52
	-4	-4.4	3.73	3.64	3.63	3.61	3.57	3.42
	0	-0.4	4.17	4.11	4.07	4.05	3.99	3.82
	5	4.5	4.70	4.64	4.60	4.58	4.52	4.34
	10	9	5.22	5.17	5.13	5.11	5.05	4.87
	17	15	5.93	5.87	5.83	<b>5.81</b>	5.75	5.56
	20	19	6.19	6.13	6.09	6.08	6.02	5.81
	25	23	6.63	6.57	6.53	6.52	6.46	6.22
	30	28	7.01	6.96	6.92	6.90	6.84	6.63
	35	32	7.40	7.34	7.30	7.28	7.22	7.04
	40	36	7.74	7.68	7.64	7.62	7.56	7.39
	45	41	8.08	8.02	7.98	7.96	7.90	7.73
	47	43	8.22	8.16	8.12	<b>8.10</b>	8.04	7.87
	50	46	8.35	8.29	8.25	8.23	8.17	7.98
	55	51	8.57	8.51	8.47	8.45	8.39	8.16
	60	56	8.57	8.51	8.47	8.45	8.39	8.20
	63	59	8.57	8.51	8.47	8.45	8.39	8.22
68	64	8.57	8.51	8.47	8.45	8.39	8.25	
KNUFB091A 9,000	-13	-13.4	3.57	3.21	3.25	3.23	3.21	3.05
	-4	-4.4	4.79	4.48	4.43	4.37	4.33	4.14
	0	-0.4	5.36	5.06	4.97	4.90	4.84	4.63
	5	4.5	6.03	5.75	5.61	5.52	5.45	5.23
	10	9	6.48	6.22	6.04	5.94	5.86	5.63
	17	15	6.97	6.73	6.52	<b>6.40</b>	6.31	6.06
	20	19	7.56	7.31	7.09	6.96	6.86	6.60
	25	23	8.54	8.29	8.03	7.89	7.78	7.49
	30	28	9.52	9.26	8.98	8.83	8.70	8.38
	35	32	10.50	10.23	9.93	9.76	9.63	9.27
	40	36	11.48	11.20	10.87	10.69	10.55	10.16
	45	41	12.45	12.17	11.82	11.63	11.47	11.06
	47	43	12.85	12.56	12.20	<b>12.00</b>	11.84	11.41
	50	46	12.88	12.62	12.31	12.13	11.99	11.59
	55	51	12.95	12.73	12.50	12.35	12.24	11.87
	60	56	13.01	12.84	12.68	12.57	12.49	12.17
	63	59	13.04	12.91	12.79	12.71	12.64	12.34
68	64	13.09	12.97	12.91	12.84	12.79	12.52	

One-Way Ceiling-Cassette

TC = Total Capacity (kBtu/h).

Nominal capacity as rated 0 ft. above sea level and a 0 ft. level difference between outdoor and indoor units. Corresponding refrigerant piping length is accordance with standard length of each outdoor unit. Nominal heating capacity rating obtained with air entering the indoor unit at 70°F dry bulb (DB) and 60°F wet bulb (WB), and outdoor ambient conditions of 47°F dry bulb (DB) and 43°F wet bulb (WB).

# ONE-WAY CEILING-CASSETTE INDOOR UNITS

## Heating Capacity Table

**MULTI F**  
**MULTI F MAX**

Table 99: Multi F One-way Ceiling-Cassette Indoor Units Heating Capacity Table.

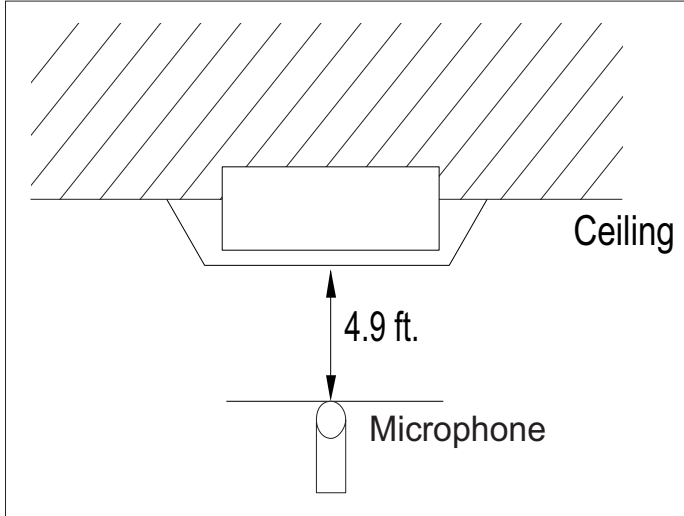
Model No. / Nominal Capacity of Indoor Unit (Btu/h)	Outdoor Air Temp.		Indoor Air Temp. °F DB					
	°F DB	°F WB	61	64	68	70	72	75
			TC	TC	TC	TC	TC	TC
KNUFB121A 12,000	-13	-13.4	4.86	4.36	4.42	4.39	4.37	4.15
	-4	-4.4	6.52	6.08	6.02	5.94	5.88	5.63
	0	-0.4	7.29	6.87	6.75	6.66	6.57	6.30
	5	4.5	8.20	7.82	7.63	7.50	7.41	7.11
	10	9	8.81	8.45	8.22	8.08	7.96	7.65
	17	15	9.48	9.15	8.86	<b>8.70</b>	8.57	8.24
	20	19	10.18	9.85	9.54	9.37	9.23	8.88
	25	23	11.35	11.01	10.67	10.49	10.34	9.95
	30	28	12.51	12.17	11.80	11.60	11.44	11.02
	35	32	13.68	13.33	12.94	12.72	12.54	12.08
	40	36	14.85	14.49	14.07	13.84	13.65	13.15
	45	41	16.02	15.65	15.20	14.95	14.75	14.22
	47	43	16.49	16.12	15.65	<b>15.40</b>	15.19	14.65
	50	46	16.53	16.20	15.80	15.57	15.38	14.87
	55	51	16.62	16.34	16.04	15.85	15.71	15.24
	60	56	16.69	16.48	16.28	16.13	16.02	15.62
	63	59	16.74	16.56	16.42	16.31	16.22	15.84
68	64	16.79	16.65	16.56	16.48	16.41	16.06	
KNUFB181A 18,000	-13	-13.4	6.27	5.63	5.71	5.67	5.64	5.36
	-4	-4.4	9.85	9.63	9.35	9.21	9.08	8.75
	0	-0.4	10.32	10.09	9.81	9.64	9.52	9.16
	5	4.5	10.91	10.67	10.36	10.19	10.06	9.69
	10	9	11.74	11.47	11.15	10.96	10.82	10.43
	17	15	12.85	12.56	12.20	<b>12.00</b>	11.84	11.41
	20	19	13.70	13.40	13.01	12.80	12.63	12.17
	25	23	15.13	14.79	14.37	14.13	13.95	13.44
	30	28	16.56	16.19	15.72	15.47	15.26	14.71
	35	32	17.98	17.58	17.08	16.80	16.58	15.97
	40	36	19.41	18.98	18.43	18.13	17.89	17.24
	45	41	20.84	20.37	19.79	19.47	19.20	18.51
	47	43	21.41	20.93	20.33	<b>20.00</b>	19.73	19.02
	50	46	21.47	21.03	20.52	20.22	19.98	19.30
	55	51	21.57	21.22	20.83	20.59	20.40	19.79
	60	56	21.68	21.40	21.14	20.96	20.81	20.28
	63	59	21.75	21.50	21.32	21.17	21.06	20.57
68	64	21.81	21.62	21.50	21.40	21.31	20.86	

TC = Total Capacity (kBtu/h).

Nominal capacity as rated 0 ft. above sea level and a 0 ft. level difference between outdoor and indoor units. Corresponding refrigerant piping length is accordance with standard length of each outdoor unit. Nominal heating capacity rating obtained with air entering the indoor unit at 70°F dry bulb (DB) and 60°F wet bulb (WB), and outdoor ambient conditions of 47°F dry bulb (DB) and 43°F wet bulb (WB).

Multi F and Multi F MAX Indoor Unit Engineering Manual

Figure 217: Sound Pressure Level Measurement Location.

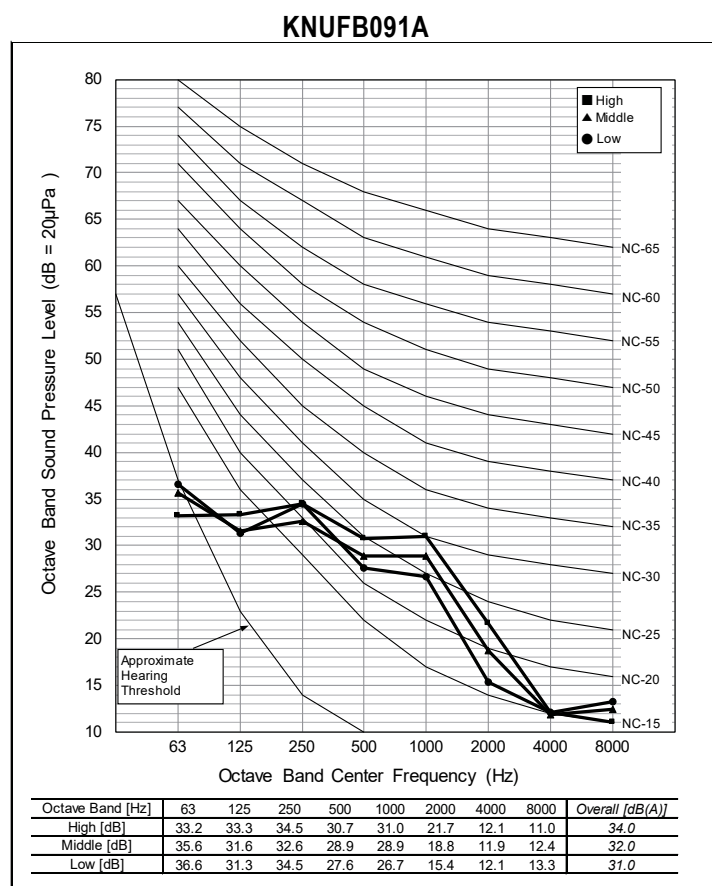
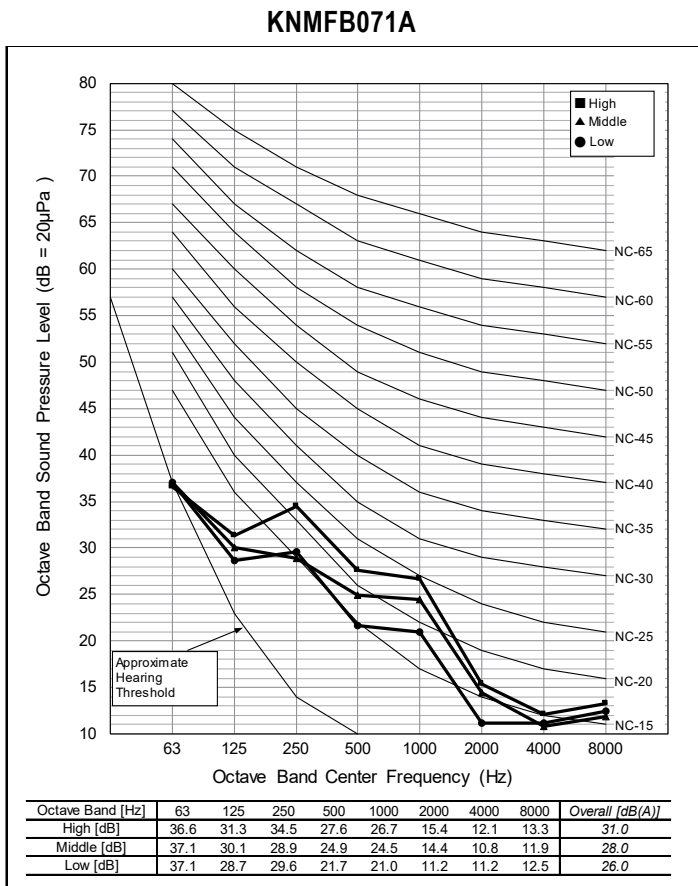


- Measurement taken 4.9' away from the unit.
- Measurements taken with no attenuation and units operating at full load normal operating condition.
- Sound level will vary depending on a range of factors such as construction (acoustic absorption coefficient) of particular area in which the equipment is installed.
- Sound power levels are measured in dB(A).
- Tested in anechoic chamber per ISO Standard 3745.

Table 100: Sound Pressure Levels (dB[A]).

Model No.	Sound Pressure Levels (dB[A]) (Cooling and Heating)		
	High Fan Speed	Medium Fan Speed	Low Fan Speed
KNMFB071A	30	28	25
KNUFB091A	33	31	30
KNUFB121A	35	33	30
KNUFB181A	44	40	35

Figure 218: KNMFB071A and KNUFB091A Sound Pressure Level Diagrams.



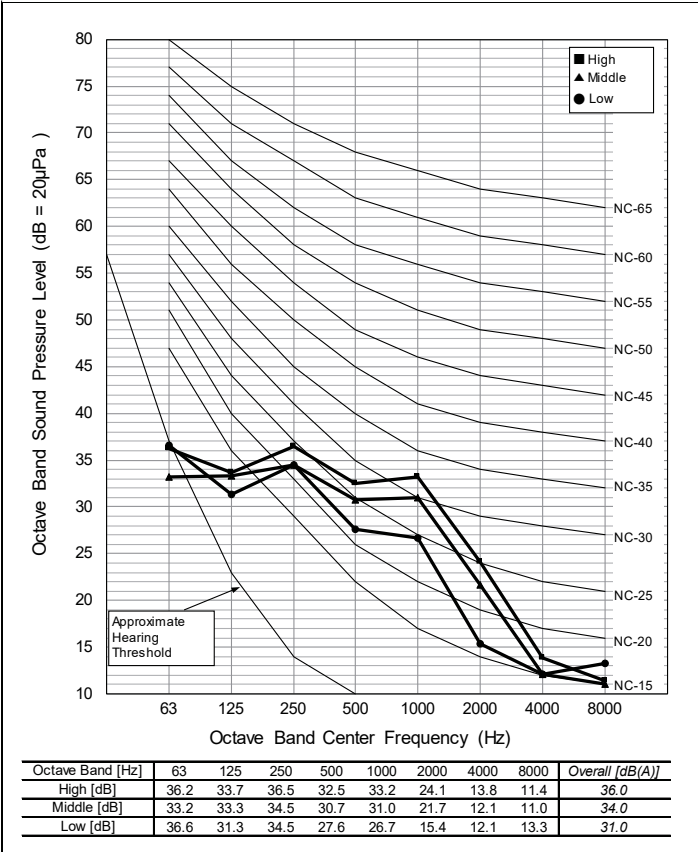
# ONE-WAY CEILING CASSETTE INDOOR UNITS

## Acoustic Data

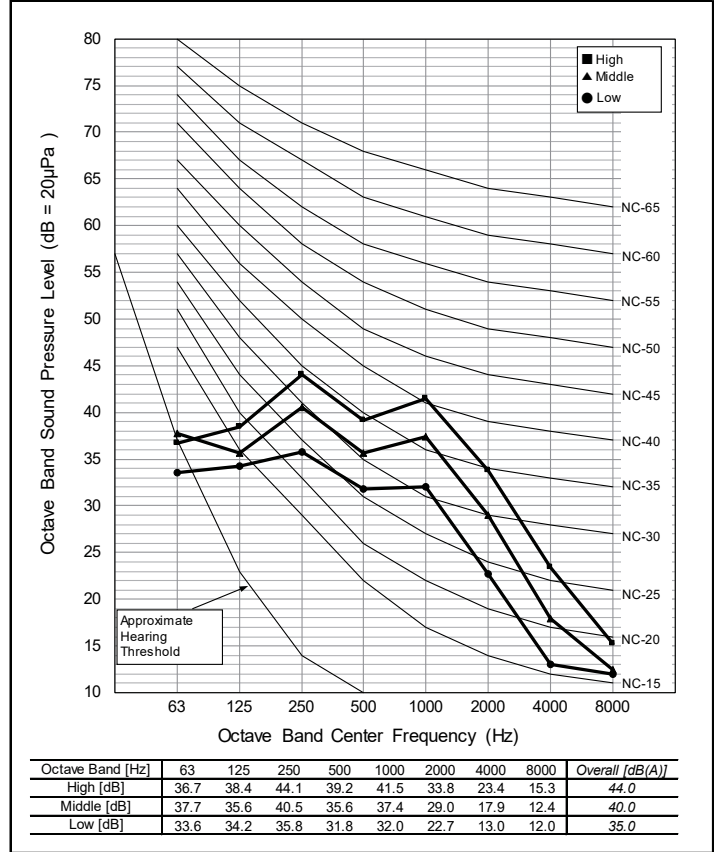
MULTI F  
MULTI F MAX

Figure 219: KNUFB121A and KNUFB181A Sound Pressure Level Diagrams.

**KNUFB121A**



**KNUFB181A**

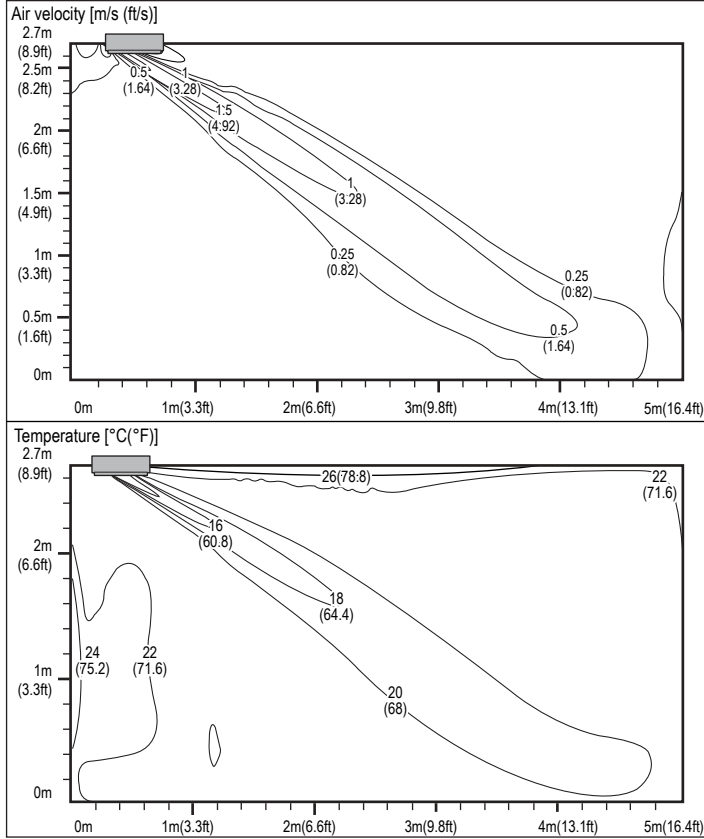


Multi F and Multi F MAX Indoor Unit Engineering Manual

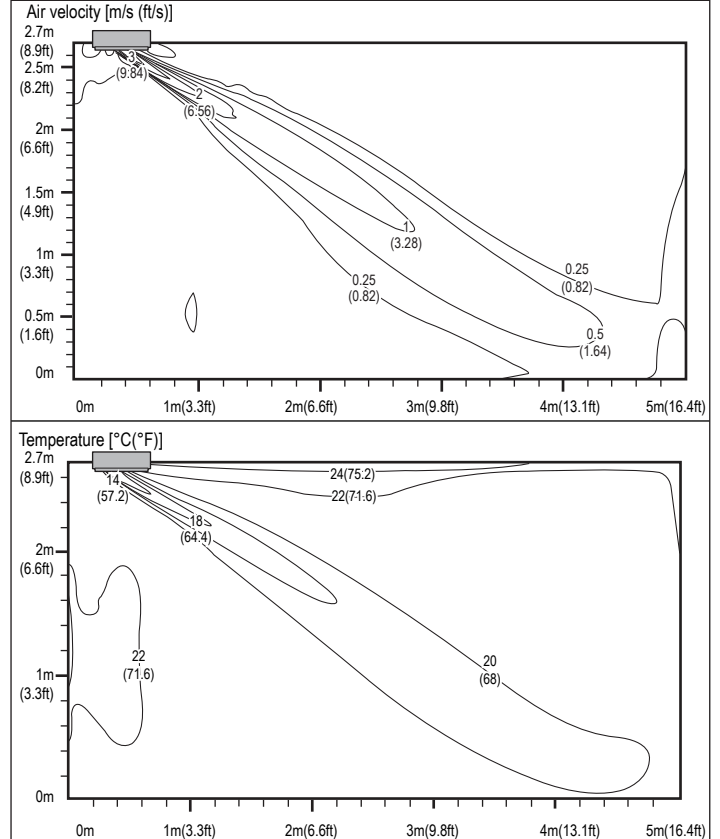
# ONE-WAY CEILING-CASSETTE INDOOR UNITS

Air Velocity and Temperature Distribution - Cooling

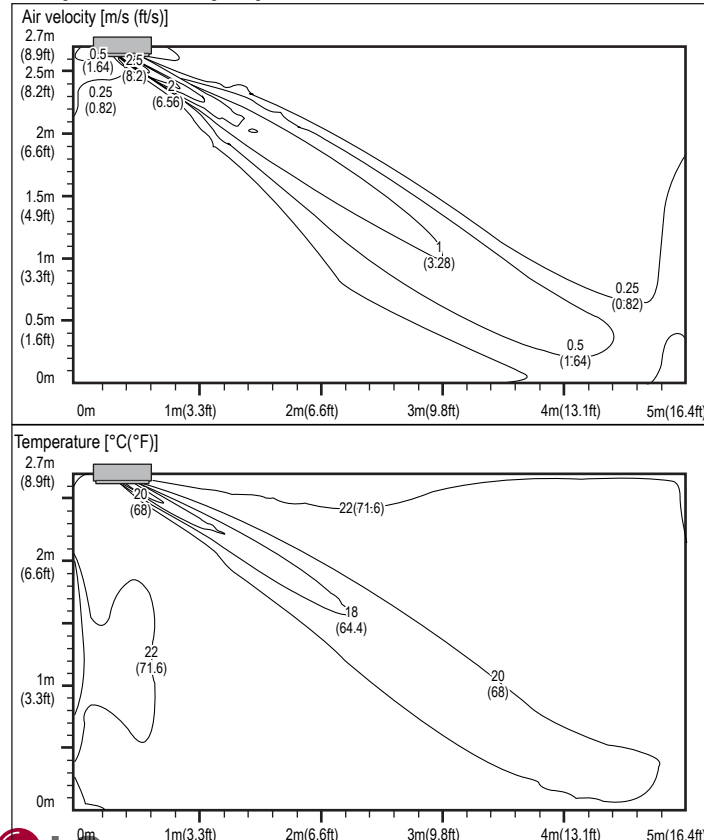
Cooling: 7kBtu - Discharge angle : Outer – 44°, Inner – 45°



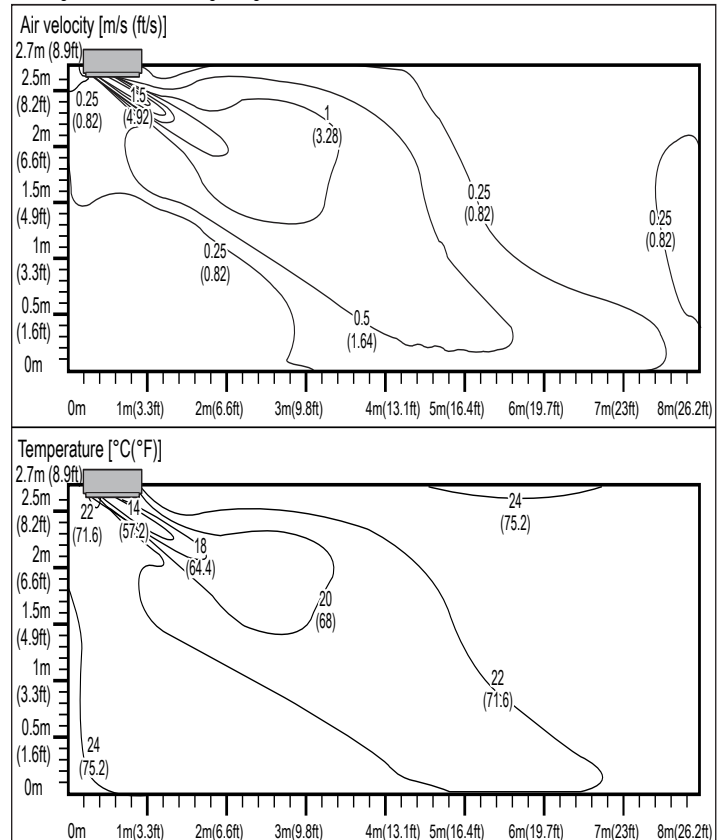
Cooling: 9kBtu - Discharge angle : Outer – 44°, Inner – 45°



Cooling: 12kBtu - Discharge angle : Outer – 44°, Inner – 45°



Cooling: 18kBtu - Discharge angle : Outer – 44°, Inner – 45°



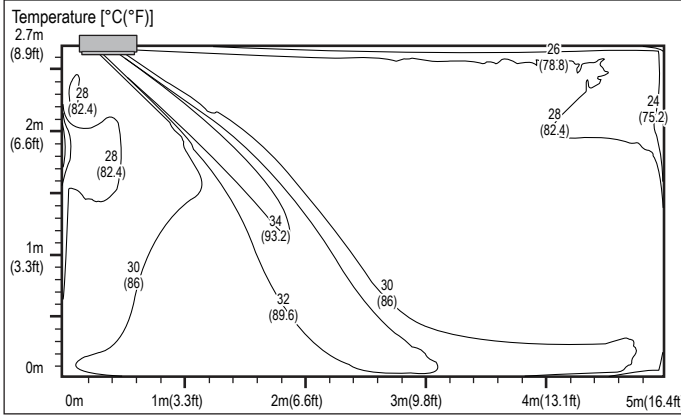
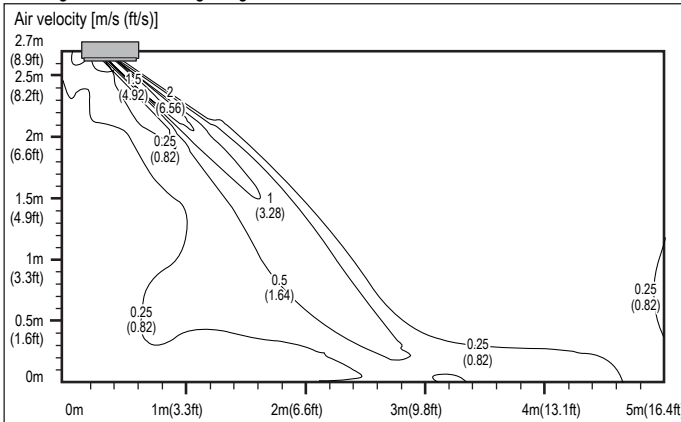
# ONE-WAY CEILING-CASSETTE INDOOR UNITS

## Air Velocity and Temperature Distribution - Heating

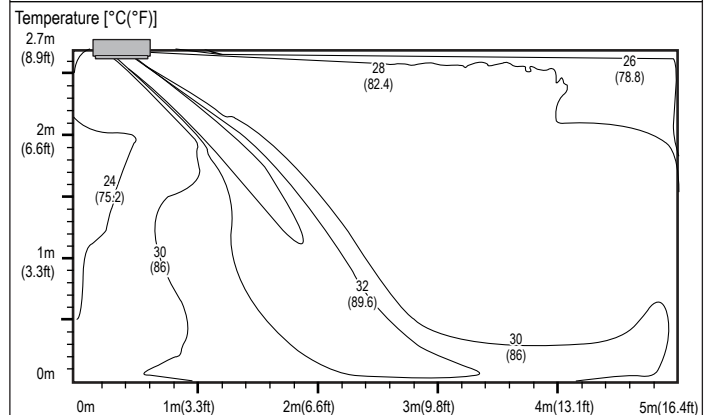
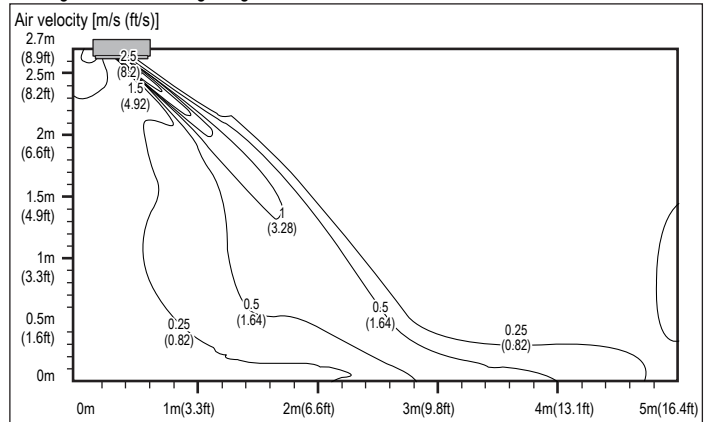
MULTI F  
MULTI F MAX

Multi F and Multi F MAX Indoor Unit Engineering Manual

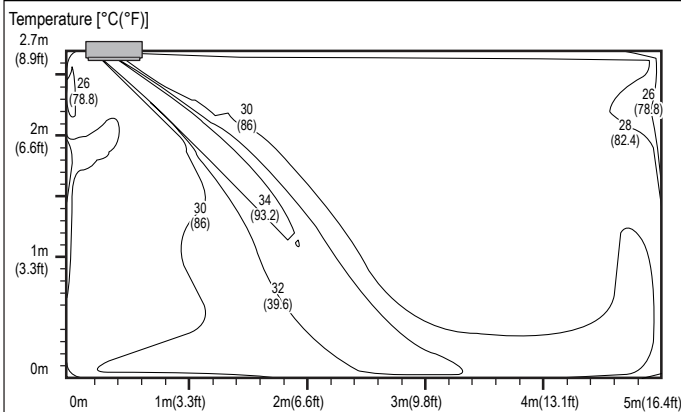
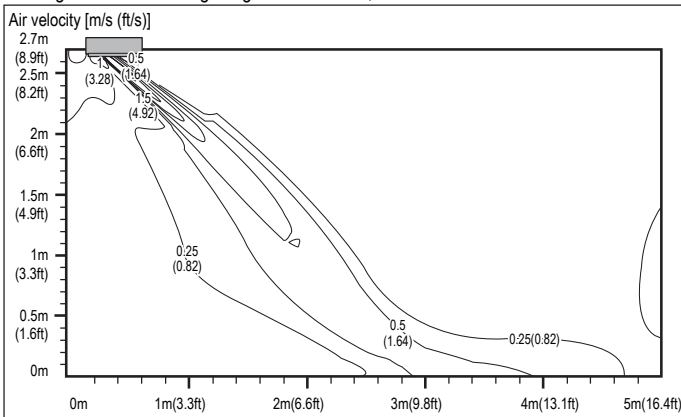
Heating: 7kBtu - Discharge angle : Outer – 53°, Inner – 47°



Heating: 9kBtu - Discharge angle : Outer – 53°, Inner – 47°



Heating: 12kBtu - Discharge angle : Outer – 53°, Inner – 47°



Heating: 18kBtu - Discharge angle : Outer – 53°, Inner – 47°

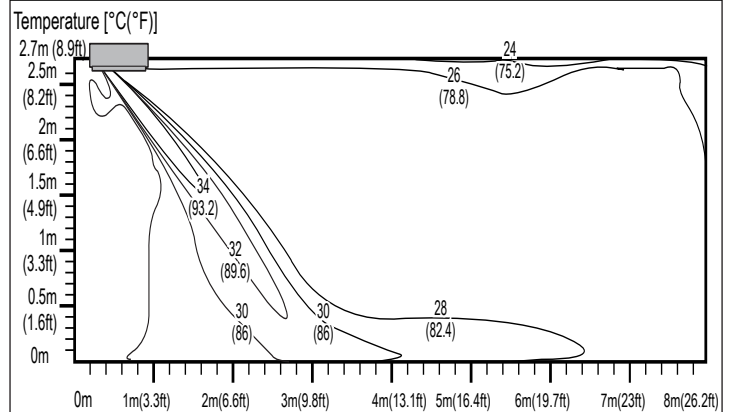
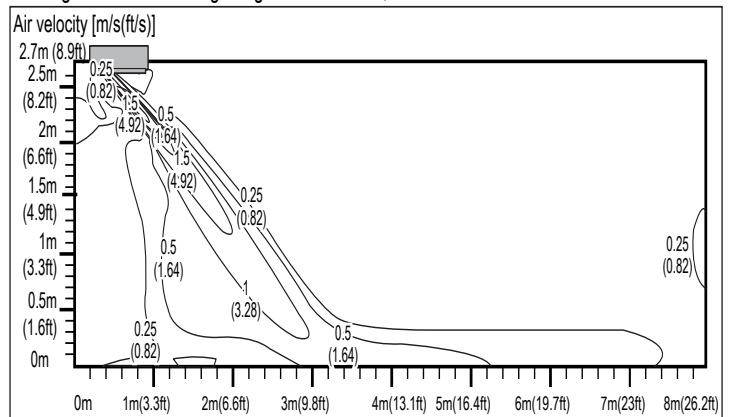


Figure 220: Multi F One-way Ceiling-Cassette Indoor Unit Refrigerant Flow Diagram.

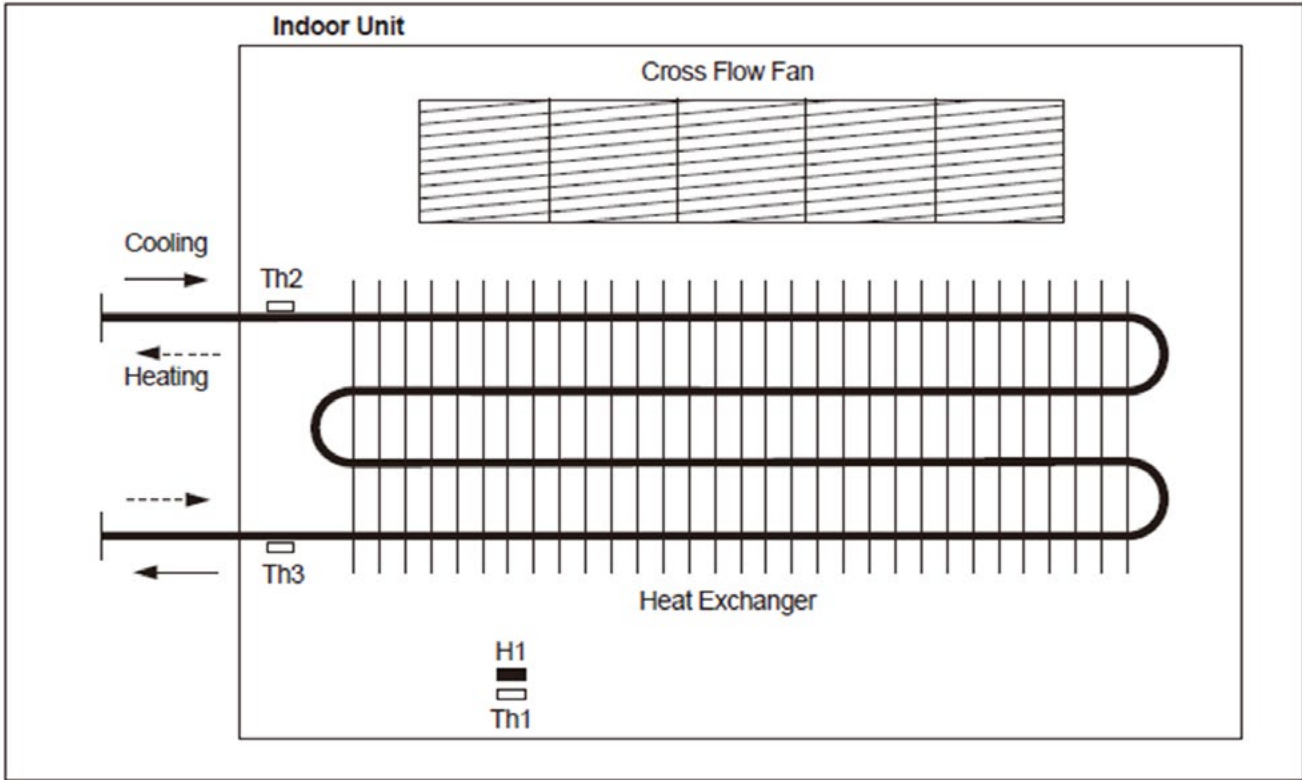


Table 101: Multi F One-way Ceiling-Cassette Indoor Unit Refrigerant Pipe Sizes.

Model No.	Vapor (inch)	Liquid (inch)
KNMFB071A	Ø3/8	Ø1/4
KNUFB091A		
KNUFB121A		
KNUFB181A	Ø1/2	

Table 102: Multi F One-way Ceiling-Cassette Indoor Unit Refrigerant Pipe Connections.

Model No.	Vapor (inch)	Liquid (inch)
KNMFB071A	Ø3/8	Ø1/4
KNUFB091A		
KNUFB121A		
KNUFB181A	Ø1/2	

Table 103: Multi F One-way Ceiling-Cassette Indoor Unit Thermistor Details.

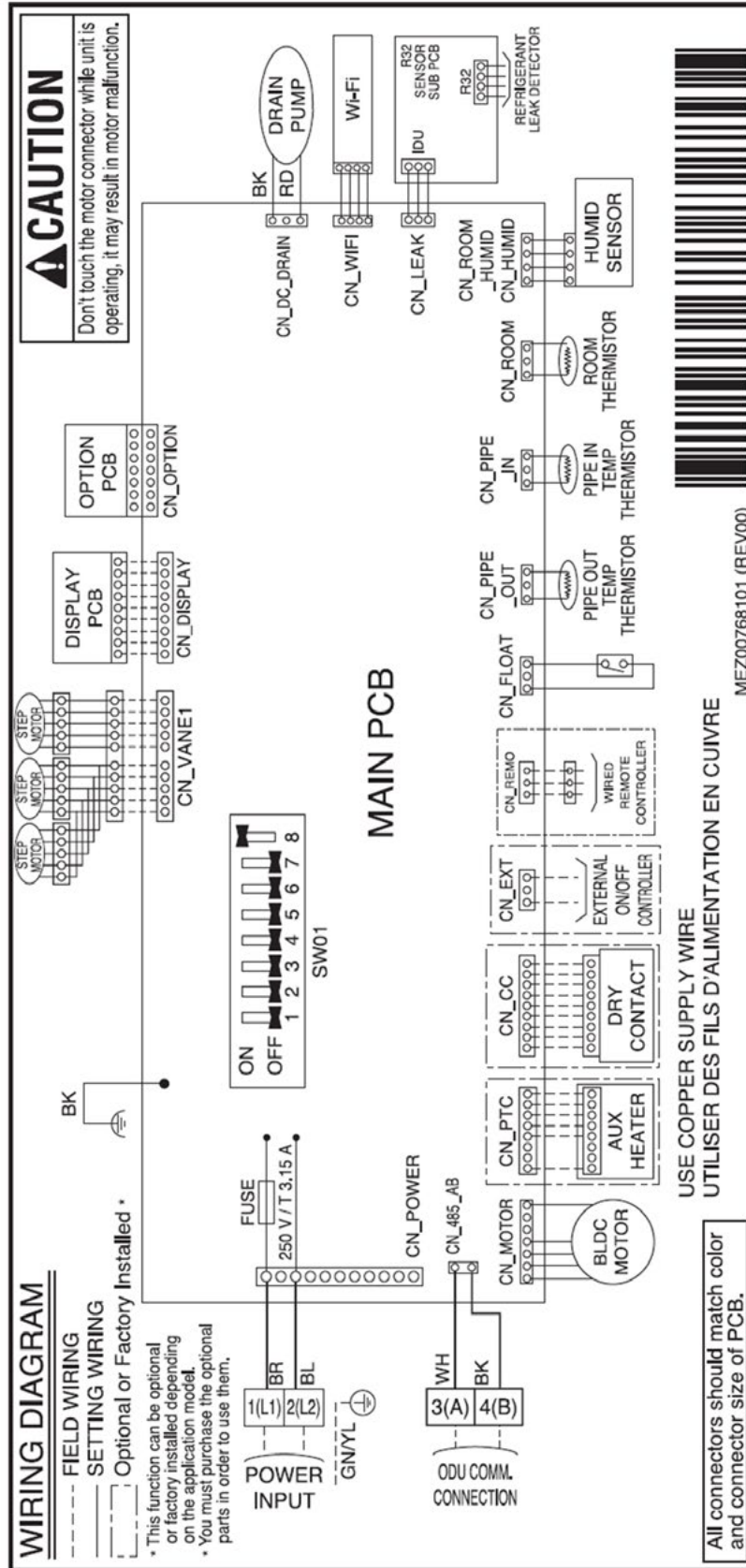
Location	Description	PCB Connector
Th1	Thermistor for indoor air temperature	CN_ROOM
Th2	Thermistor for evaporator inlet temperature	CN_PIPE_IN
Th3	Thermistor for evaporator outlet temperature	CN_PIPE_OUT
H1	Humidity sensor for indoor air humidity	CN_ROOM_HUMID

# ONE-WAY CEILING CASSETTE INDOOR UNITS

## Wiring Diagram

MULTI F  
MULTI F MAX

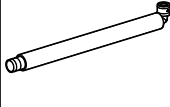


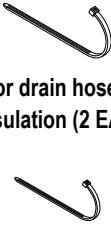

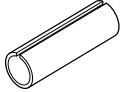

Figure 221: Multi F One-way Ceiling-Cassette Indoor Unit Wiring Diagram.



Multi F and Multi F MAX Indoor Unit Engineering Manual

## Factory Supplied Parts

Table 104: Parts Table.

Name	Drain hose	Clamp metal	Washer	Plastic band	Pipe insulation
Quantity	1 EA	2 EA	8 EA	6 EA	1 SET
Shape		 for drain hose and pipe	 for hanging bracket	 for drain hose insulation (2 EA)  for pipe insulation (4 EA)	 for gas pipe (1 EA)  for liquid pipe (1 EA)





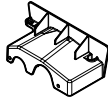



Name	Drain hose insulation	Connection pipe (18kBtu/h only)	Drain cover	Screw	(Other)
Quantity	1 EA	1 SET	1 EA	2 EA	
Shape		 (1 EA)  (1 EA)  (1 EA)		  for drain cover	<ul style="list-style-type: none"> <li>• Paper pattern for installation</li> <li>• Manual</li> </ul>

Table 105: Required Accessory Table.

Part	Quantity	Image
Grille Kit (PT-UCA)	One (1)	

## Factory Supplied Materials

- Installation Guide (template)
- Owner's Manual
- Installation Manual

## Required Tools

- Level
- Screwdriver
- Electric drill
- Hole core drill
- Flaring tool set
- Torque wrenches
- Hexagonal wrench
- Gas-leak detector
- Thermometer

### **⚠ WARNING**

Installation work must be performed by trained personnel and in accordance with national wiring standards and all local or other applicable codes. Improper installation can result in fire, electric shock, physical injury, or death.

### **NOTICE**

Read all instructions before installing this product. Become familiar with the unit's components and connections, and the order of installation. Incorrect installation can degrade or prevent proper operation.



# ONE-WAY CEILING CASSETTE INDOOR UNITS

## Installation and Best Layout Practices

MULTI F  
MULTI F MAX

### Selecting the Best Location

#### Do's

- Place the unit where air circulation will not be blocked.
- Place the unit where drainage can be obtained easily.
- Place the unit where noise prevention is taken into consideration.
- Ensure there is sufficient strength to bear the load of the indoor unit.
- Ensure there is sufficient maintenance space.
- Locate the indoor unit in a location that is level, and where it can be easily connected to the outdoor unit / branch distribution unit.

#### Don'ts

- Do not install the unit near a heat or steam source, or where considerable amounts of oil, iron powder, or flour are used.
- Do not install the unit where sulfuric acid and flammable or corrosive gases are generated, vented into, or stored.
- Do not install the unit near high-frequency generators.
- Do not install the unit near a doorway.

The unit will be damaged, will malfunction, and/or will not operate as designed if installed in any of the conditions listed.

#### NOTICE

- Indoor units (IDUs) must not be placed in an environment where the IDUs will be exposed to harmful volatile organic compounds (VOCs) or in environments where there is improper air make up or supply or inadequate ventilation. If there are concerns about VOCs in the environment where the IDUs are installed, proper air make up or supply and/or adequate ventilation must be provided. Additionally, in buildings where IDUs will be exposed to VOCs, consider a third party factory-applied epoxy coating to the fan coils for each IDU where the entire coil is dipped, not sprayed.
- If the unit is installed near a body of water, the installation parts are at risk of corroding. Appropriate anti-corrosion methods must be taken for the unit and all installation parts.

### Installing in a High or Dropped Ceiling

High or dropped ceilings, often found in commercial buildings and offices, will cause a wide temperature differentiation. To countermeasure:

- Change the indoor unit mode selection to allow for higher ceilings (see table).
- Install an air circulator.
- Set the air discharge outlet so that heated air flows in a downward direction.
- Use a dual door system to protect the building gate or exit.

### Installing in an Area Exposed to Unconditioned Air

In some installation applications, areas (floors, walls) in some rooms will be exposed to unconditioned air (room will be above or next to an unheated garage or storeroom). To countermeasure:

- Verify that carpet is or will be installed (carpet will increase the temperature by three (3) degrees).
- Add insulation between the floor joists.
- Install radiant heat or another type of heating system to the floor.

### Installing in an Area with High Humidity Levels

If the environment is prone to humidity levels of 80% or more (near the ocean, lakes, etc.) or where steam could collect in the plenum:

- Install additional insulation to the indoor unit (glass wool insulation >13/32 inches thick).
- Install additional insulation to the refrigerant piping (insulation >13/16 inches thick).
- Seal all gaps between the indoor unit and the ceiling tiles (make the area air tight) so that humidity does not transfer from the plenum to the conditioned space. Also, add a ceiling grille for ventilation.

Figure 222: Indoor Unit Clearance Requirements.

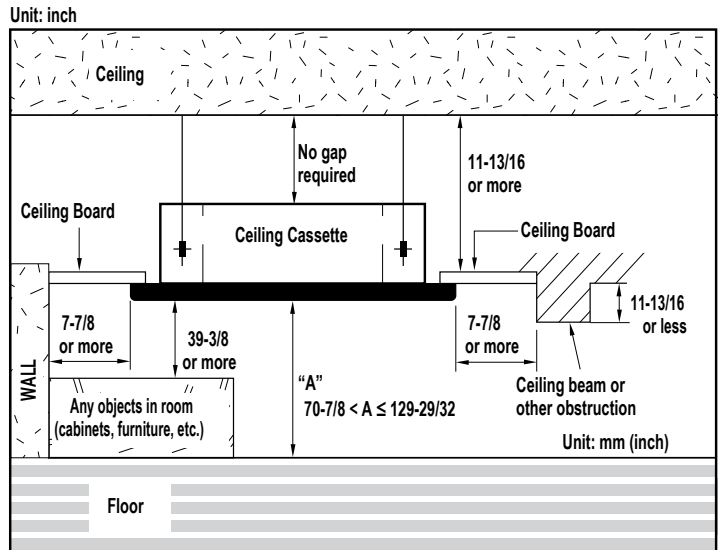
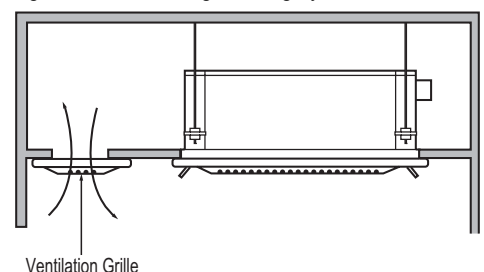


Table 106: Indoor Unit High Ceiling Mode Selection Options.

Ceiling Height	Mode Selection
≤7-1/2 feet	Low Ceiling
7-1/2 feet to 8-7/8 feet	Standard
8-7/8 feet to 10-3/16 feet	High Ceiling
10-3/16 feet to 11-13/16 feet	Very High Ceiling

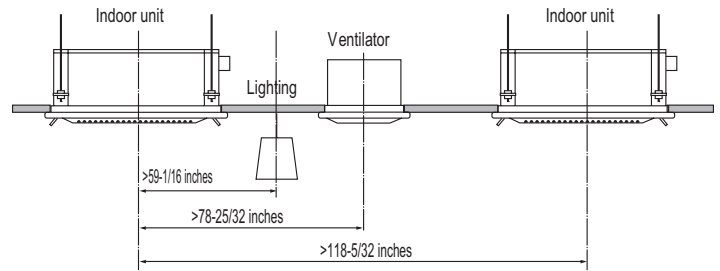
Figure 223: Installing in a Highly Humid Location.



### Installing Multiple Indoor Units in One Area

Ensure there is enough space between indoor units, lighting fixtures, and ventilation fans / systems.

Figure 224: Installing Multiple Indoor Units.

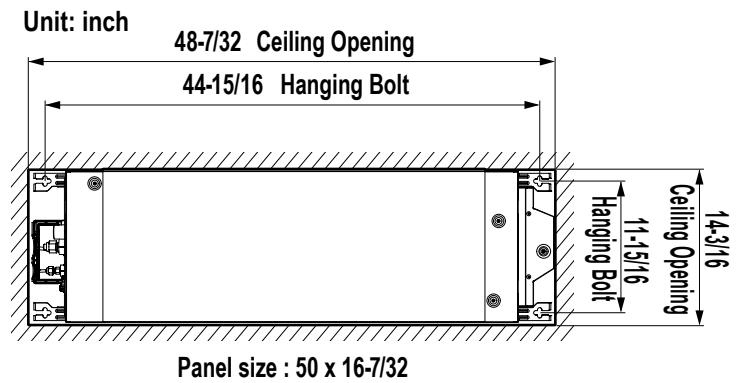


## Preparing the Installation Area and Hanging the Indoor Unit Frame

### Preparing the Installation Area

1. Installation guide (template) depicts the exact dimensions necessary for the ceiling opening.
2. Choose the location for the indoor unit, and then mark where the bolts, refrigerant piping, and drain hose must be. Suspension bolt angle must account for drain direction.
3. Drill holes for the bolts. Use either a W 3/8 inch or a M10 size bolt.

Figure 225: Ceiling Opening Dimensions and Bolt Locations.



### NOTICE

For easier installation, attach the accessories (except for the decoration panel) before hanging the indoor unit.

Figure 226: Installing the Hanging Bolt in the Ceiling.

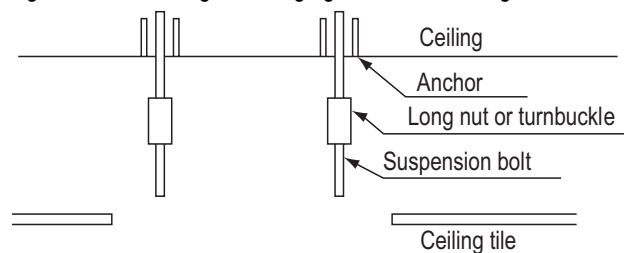
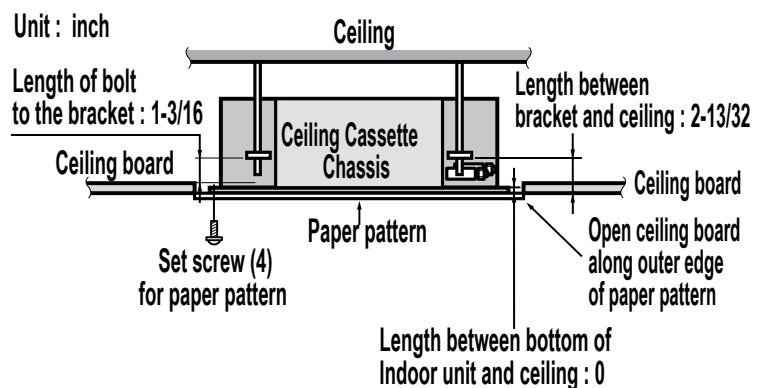


Figure 227: Installation Diagram.



# ONE-WAY CEILING CASSETTE INDOOR UNITS

## Installation and Best Layout Practices

MULTI F  
MULTI F MAX

### For New Ceilings

1. Use a sunken insert, a sunken anchor, or any other field-supplied part to reinforce the ceiling so that it can bear the weight of the indoor unit. Use a temporary washer plate to more easily set up the unit suspension location.
2. Ceiling height is shown on the side of the installation guide (template). Adjust the height of the unit accordingly. Adjust the clearance before hanging the indoor unit.
3. Refer to the installation guide (template) for the dimensions to the ceiling opening. Match the center of the indoor unit (labeled) to the center indicated on the installation guide.
4. Align the installation guide (template) with the label attached to the unit (affixing the template to the unit if desired) to properly place the unit.
5. Remove the temporary washer plate and position the indoor unit hanger brackets on the bolts. Secure with nuts and washers on the top and bottom of the hanger brackets.
6. Ceiling-cassette indoor units are equipped with a built-in drain pump and float switch, therefore, the unit must be installed horizontally or condensate will drip out and cause product malfunction. Measure the unit at each corner to verify that it is level.
7. Remove the installation guide (template).

### For Existing Ceilings

1. Use anchors when installing the indoor unit in an existing ceiling.
2. Ceiling height is shown on the side of the installation guide (template). Adjust the height of the unit accordingly. Adjust the clearance before hanging the indoor unit.
3. Remove the temporary washer plate and position the indoor unit hanger brackets on the bolts. Secure with nuts and washers on the top and bottom of the hanger brackets.
4. Ceiling-cassette indoor units are equipped with a built-in drain pump and float switch, therefore, the unit must be installed horizontally or condensate will drip out and cause product malfunction. Measure the unit at each corner to verify that it is level.
5. Remove the installation guide (template).

## Installing the Drain System

- Drain piping must have downward gradient of at least 1/50 to 1/100; to prevent reverse flow, slope must not be straight up and down.
- Do not damage the drain port on the indoor unit when connecting the field-supplied drain piping.
- Drain piping specifications:
  - Indoor Unit Drain Connection: 1-1/4 inch outside diameter.
  - Field-Supplied Drain Piping: Polyvinyl chloride piping with 1-inch inside diameter and pipe fittings.

## Checking the Drain Pump

The unit uses a drain pump to remove condensate. The pump must be tested before the system operates.

- Connect flexible drain hose to the field-installed drain piping; leave it as is until the test is complete.
- Pour water into the flexible drain hose and check for leaks.
- After power wiring installation is complete, operate the drain pump to see if it sounds and functions properly.
- After the test is complete, connect the flexible drain hose to the indoor unit drain port.

Figure 228: Hanging the Indoor Unit.

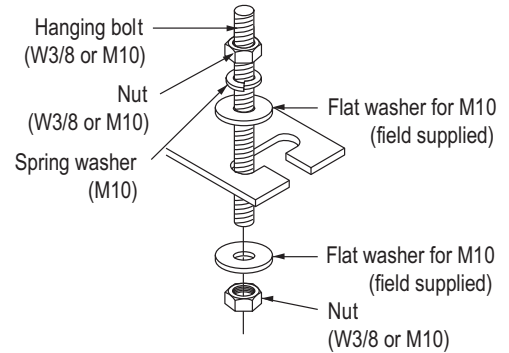


Figure 229: Indoor Unit Drain Piping.

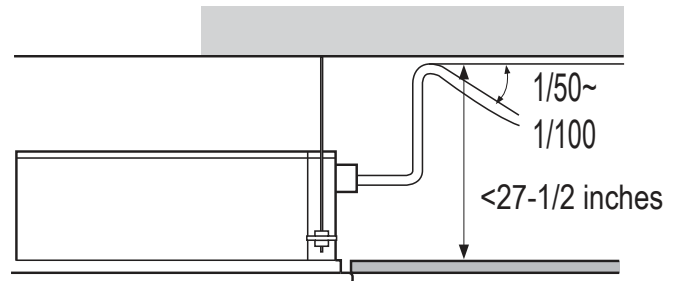
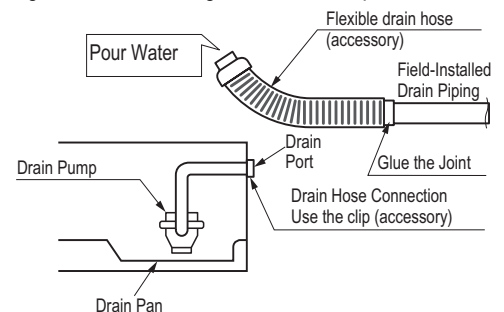


Figure 230: Checking the Drain Pump.



### Insulating the Refrigerant and Drain Piping

#### ⚠ WARNING

Ensure all piping is insulated. Exposed piping can cause burns if touched.

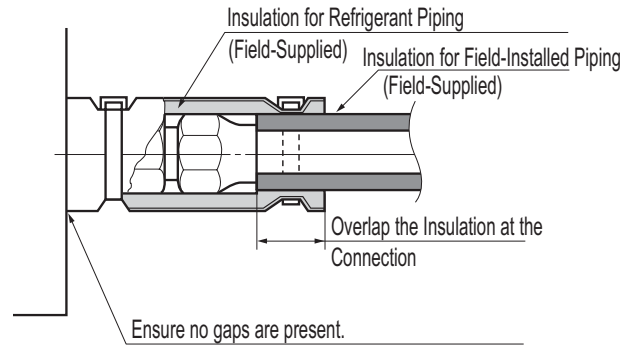
#### Refrigerant Piping Insulation

Field-installed vapor and liquid refrigerant piping lines must be properly and completely covered in insulation (up to the indoor unit piping connections). Any exposed piping will generate condensate or will cause burns if touched. Insulation for this field-installed refrigerant piping must have a minimum heat resistance of 248°F.

#### Drain Piping Insulation

Drain piping must have insulation a minimum of 7/32 inches thick.

Figure 231: Insulating the Piping.



#### Installing the Insulation

1. Overlap the insulation at the connection of the field-installed piping and the indoor unit piping. Tape together so that no gaps exist.
2. Secure insulation to the rear piping housing section with vinyl tape.
3. Bundle the piping and drain hose with tape where they meet at the back of the indoor unit frame. Position the drain hose at the bottom of the bundle (positioning the drain hose at the top of the bundle will cause the drain pan to overflow inside the indoor unit).

### Power Wiring / Communications Cable Guidelines

- Follow manufacturer's circuit diagrams in the technical manuals.
- Confirm power source specifications.
- Confirm that the electrical capacity is sufficient.
- Starting current must be maintained  $\pm 10$  percent of the rated current marked on the outdoor unit name plate.
- Confirm cable thickness specifications.
- It is required that a circuit breaker is installed, especially if conditions could become wet or moist.
- Include a disconnect in the power wiring system, add an air gap contact separation of at least 1/8 inch in each active (phase) conductor.

#### ⚠ WARNING

Loose wiring will cause unit to malfunction, overheat, and catch fire, resulting in severe injury or death.

#### NOTICE

- Terminal screws will become loose during transport. Properly tighten the terminal connections during installation.
- A voltage drop will cause the following problems:
- Magnetic switch vibration, fuse breaks, or disturbance to the normal function of an overload protection device.
  - Compressor will not receive the proper starting current.

### Connecting the Power Wiring and Communications Cable

1. To access the terminal block, open the control box cover.
2. Insert the power wiring / communications cable from the outdoor unit or branch distribution unit (Multi F MAX systems only) through the sides of the indoor unit and control box. Pass the wiring through the designated access holes to prevent damage. To prevent electromagnetic interference and product malfunction, leave a space between the power wiring and communications cable outside of the indoor unit.
3. Connect each wire to its appropriate terminal on the indoor unit control board. Verify that the color and terminal numbers from the outdoor unit or branch distribution unit (Multi F MAX systems only) wiring match the color and terminal numbers on the indoor unit.
4. Neatly arrange power wiring / communications cable and secure with the appropriate cable restraint. ⚠ When clamping, ⚠ do not apply force to the wiring connections.
5. Firmly reattach the control box cover. ⚠ Do not catch the wiring in the electric box cover and make sure the cover firmly closes.
6. Fill in any gaps around the wiring access holes with sealant to prevent foreign particles from entering the indoor unit.

Figure 232: Power Wiring and Communications Cable Connection Access.

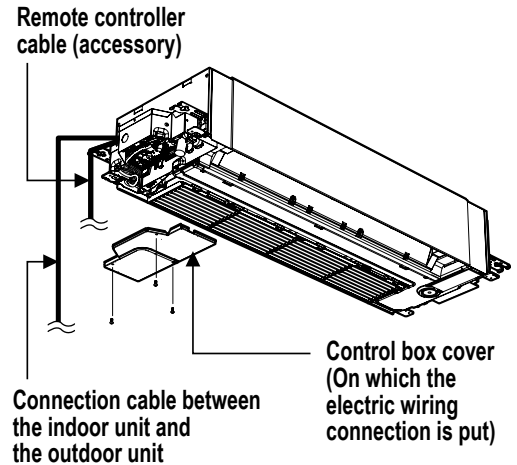


Figure 233: Simplified View of Indoor Unit to Outdoor Unit / Branch Distribution Unit Terminal Connections.

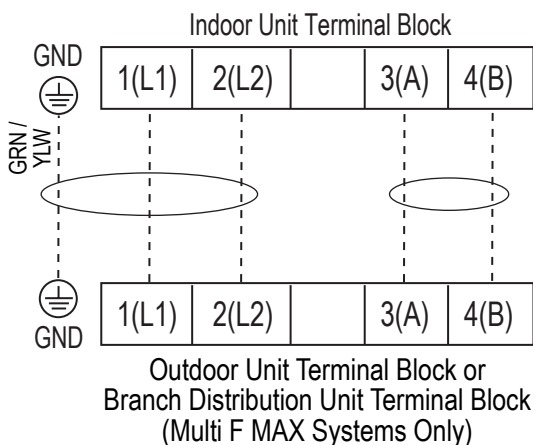
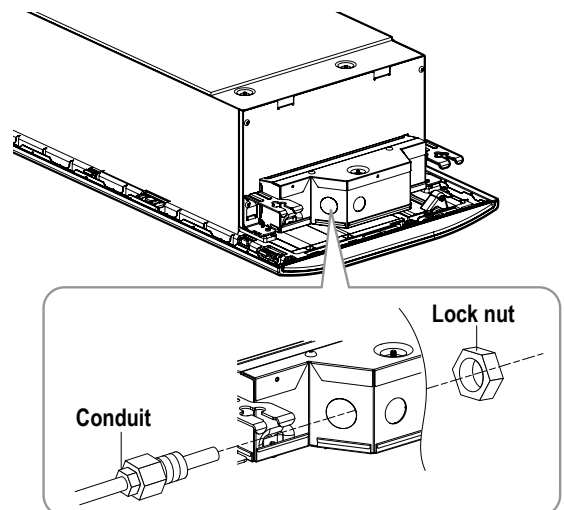


Figure 234: Using a Conduit.



### Using a Conduit

1. Remove the rubber stopper on the indoor unit. Pass the power wiring / communications cable through the conduit, the conduit mounting plate, and to / through the control panel of the indoor unit.
2. Tighten the conduit and the conduit mounting plate together.
3. Connect the power wiring / communications cable to the indoor unit terminal block.
4. Screw the conduit mounting plate to the indoor unit.

### Controller Options

One-way ceiling-concealed indoor units include a wireless handheld controller (AKB75735426), but optional LG-supplied wired controllers are available.

#### Wireless Handheld Controller

Figure 235: AKB75735426 Wireless Handheld Controller.

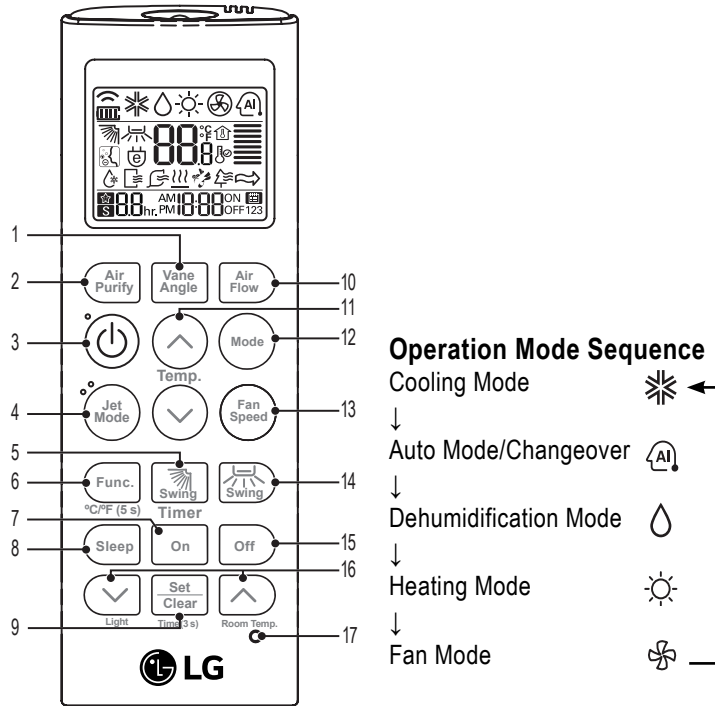


Table 107: AKB75735426 Wireless Handheld Controller Functions.<sup>1</sup>

Button Label	Description
1	Vane Angle Button: Sets the angle to each vane.
2	Starts / stops the air purification function.
3	On / Off Button: Turns the power on/off.
4	Jet Mode: Sets unit to super high fan speed when in cooling mode.
5	Adjust air flow direction vertically.
6	Sets or clears additional functions
7	On Time Button: Sets the time when operation begins.
8	Sleep Timer Button: Sets sleep mode operation.
9	Set/Clear Button: Sets or cancels timer. Also sets current time.
10	Air Flow button: Sets airflow.
11	Room Temperature Setting Buttons: Raises or lowers temperature setpoint in cooling and heating operation.
12	Operation mode selection button: Selects operation mode.
13	Indoor Fan Speed Button: Sets the fan speed.
14	Adjust air flow direction horizontally.
15	Off Timer button: Sets the time when operation ends.
16	Time Setting (Up / Down) / Light Button: Sets the timer and adjusts the brightness of the LED.
17	Reset Button: Resets the handheld controller.

<sup>1</sup>Depending on the indoor unit model, some functions will not be supported or displayed.

#### Wired Controller Connections

Controllers can connect to the indoor unit in one of two different ways.

1. LG Wired Remote Extension Cable with Molex plug (PZC-WRC1; sold separately) that connects to the CN-REMO terminal on the indoor unit PCB.
2. Field-supplied controller cable that connects to the indoor unit terminal block (must be at least UL2547 or UL1007, 22 AWG, two-core, one-shield core, at least FT-6 rated if local electric and building codes require plenum cable usage).

#### NOTICE

When using field-supplied controller cable, make sure to connect the yellow to yellow (communications wire), red to red (12V power wire), and black to black (ground wire) terminals from the remote controller to the indoor unit terminal blocks.

Figure 236: PZCWRC1 LG Wired Remote Extension Cable.

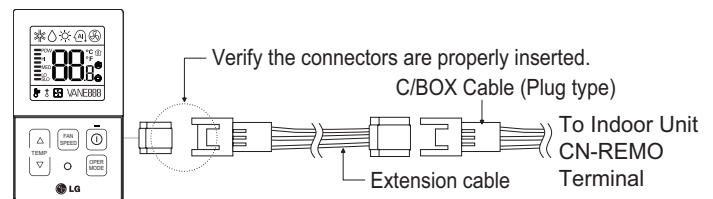
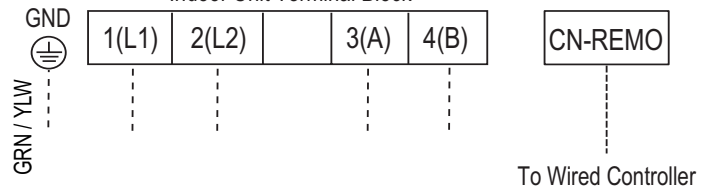


Figure 237: Wired Controller Connections on the Indoor Unit Terminal Block.



# ONE-WAY CEILING CASSETTE INDOOR UNITS

## Installation and Best Layout Practices

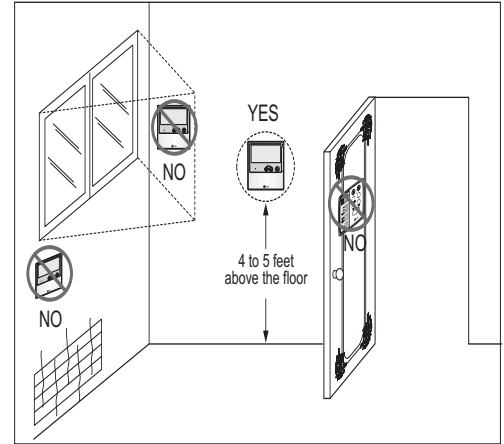
MULTI F  
MULTI F MAX

### Wired Controller Placement

Wall indoor units can be used with various wired controllers (optional; sold separately). Wired controllers include a sensor to detect room temperature. To maintain comfort levels in the conditioned space, the wired controller must be installed in a location away from direct sunlight, high humidity, and where it could be directly exposed to cold air. Controller must be installed four (4) to five (5) feet above the floor where its display can be read easily, in an area with good air circulation, and where it can detect an average room temperature.

- ⊘ Do not install the remote controller where it can be impacted by the following:
- Drafts or dead spots behind doors and in corners
  - Hot or cold air from ducts
  - Radiant heat from sun or appliances
  - Concealed pipes and chimneys
  - Uncontrolled areas such as an outside wall behind the remote controller

Figure 238: Proper Location for the Wired Controller.



### Hanging the Wired Controller

1. The controller wiring / cable can be installed in one of three directions: top, back, or on the right side. If top or right side installation is desired, remove cable guide grooves on the controller, and then position wiring / cable on applicable side.
2. Choose and mark the area of installation, and then screw the wall plate into place (using the provided parts). Install the controller wall plate to fit the electrical box if one is present. Ensure that no gaps exist between the wall plate and the wall itself.
3. Arrange wiring / cables so as not to interfere with the controller circuitry. Position the wired controller on the wall plate. Snap into place by pressing the bottom part of the wired controller onto the wall plate. Make sure that no gaps exist between the wired controller and the wall plate on all sides.
4. To remove wired controller from the wall plate, insert a screwdriver into the two holes at the bottom. Twist screwdriver to release controller. ⊘ Do not damage the controller components when removing.

Figure 239: Removing the Cable Guide Grooves.

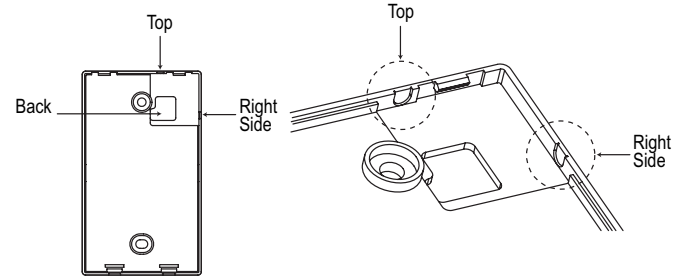


Figure 240: Attaching the Wall Plate.

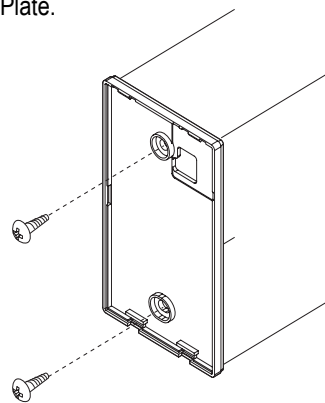
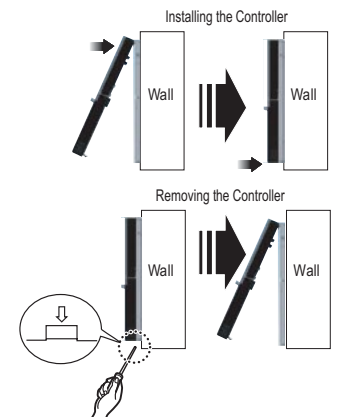


Figure 241: Installing / Removing the Controller.



### Assigning the Thermistor for Temperature Detection

Each indoor unit includes a return air thermistor assigned to sense the temperature. If a wired controller is installed, there is a choice of sensing temperature with either the indoor unit return air thermistor or the thermistor in the wired controller. It is also an option to set both thermistors to sense temperature so that indoor unit bases its operation on the first thermistor to reach the designated temperature differential. For applicable indoor units, an optional Remote Temperature Sensor can be used in lieu of the return air thermistor—either alone or in conjunction with a wired controller thermistor as previously described.

# MULTI POSITION AIR HANDLING UNIT INDOOR UNIT DATA

**Mechanical Specifications on page 188**

**General Data / Specifications on page 189**

**Dimensions on page 191**

**Cooling Capacity Table on page 193**

**Heating Capacity Table on page 196**

**External Static Pressure on page 199**

**Heater Capacities on page 200**

**Acoustic Data on page 201**

**Refrigerant Flow Diagram on page 203**

**Wiring Diagram on page 204**

**DIP Switch Settings on page 207**

**Factory Supplied Parts and Materials on page 208**

**Installation and Best Layout Practices on page 209**

# MULTI POSITION AIR HANDLING UNIT INDOOR UNITS

MULTI F  
MULTI F MAX

## Mechanical Specifications and Features

### Multi Position Air Handling Indoor Unit

#### General

All LG indoor units are factory assembled, wired, piped, and provided with a control circuit board, and constant CFM ECM fan. Multi Position Air Handling units are designed for high-speed air volume against an external static pressure up to 1.0"WG. Supply air opening is flanged to accept field-installed ductwork that cannot exceed the external static pressure limit of the unit.

#### Coil

Indoor unit coils are factory built and are comprised of aluminum fins mechanically bonded to copper tubing. Each unit has a minimum of two rows of coils, which are pressure tested at the factory. Each unit is provided with a factory installed condensate drain pan below the coil.

#### Refrigerant System

System is designed for use with R32 refrigerant. The refrigeration circuit is pressure-tested at the factory and shipped with a holding charge of helium gas. Refrigerant pipe connections are 45° flare, and all refrigerant lines from the outdoor unit to the indoor units must be field insulated.

#### Electrical

Each indoor unit is designed to operate using 208–230/60/1 power with voltage variances of ±10%.

#### Casing

The casing is designed to mount fully concealed behind a wall or above a finished ceiling. Casing is manufactured of 22-gauge metal and finished with a high-gloss baked enamel finish. Cold surfaces of the unit are covered internally with 1/2-inch polystyrene fiber insulation; inside surface of the pan assembly door access panel is treated with 1/2-inch polystyrene fiber insulation, encapsulated on both sides. The access panel is sealed along the edges with reinforced foil-faced covering, all access panels also have gasket seals to minimize air leaks.

The Multi Position Air Handling Unit can operate in one of four airflow configurations: vertical upflow, vertical downflow, horizontal left discharge, or horizontal right discharge. Vertical downflow operation requires an optional conversion kit. In the vertical position, the unit has an opening for supply air from top (or bottom) with a dedicated bottom (or top) vertical return. In the horizontal position, supply air is from the left (or right) end with the return air from the right (or left) end. The unit can also accept an optional internal LG electrical strip heater.

#### Fan Assembly and Control

The units have an integral fan assembly consisting of galvanized steel housing and a forward curve fan wheel. The ECM (electronically commutated motor) fan is programmed to deliver constant CFM throughout the published ESP (external static pressure) range, and has permanently lubricated and sealed ball bearings. The fan / motor assembly is mounted on vibration-attenuating rubber grommets. Fan speed is controlled using a microprocessor-based direct digital control algorithm. The indoor fan has Low, Med, High, and Auto settings for

Cooling mode; and has Low, Med, High, and Auto settings for Heating mode. Low, Med and High fan speeds maintain published airflow as the ECM motor adjusts to ESP. The Auto setting adjusts the fan speed to most effectively achieve setpoint.

#### Filter Assembly

The unit comes with a filter rack sized to hold a field-provided 16" x 20" x 1" (for 12k, 18k, and 24k units) or 20" x 20" x 1" (for 30k and 36k units) filter cartridge. The filter rack has a guide to assist in centering the filters, and can be accessed from the front.

#### Microprocessor Control

The indoor unit is provided with an integrated control board to communicate with the outdoor unit. All unit operation parameters are stored in non-volatile memory resident on the unit microprocessor. The microprocessor controls space temperature through using the value provided by temperature sensors within the indoor unit. A field-supplied three-wire power cable (3 x 14 AWG) and two-wire communications cable (2 x 18 AWG) must be installed to connect the indoor unit(s) to the outdoor unit.

#### R32 Refrigerant Leak Detector

The indoor unit has a built-in R32 refrigerant leak detection sensor designed to communicate with release mitigation devices and third party alarms, and transmit a system error code upon detection of a refrigerant leak or sensor failure / expiration.

#### Shut-off Valve

LG single-port shutoff valve (PRHPZ010A; sold separately) is available as an accessory.

#### Controls

The indoor unit controller of choice must be ordered separately. Communication between the indoor units and the outdoor unit is accomplished through 18 AWG, two-core, stranded and shielded communication cable. The indoor unit can accommodate an optional dry contact for a field supplied 3rd party thermostat. An optional Wi-Fi module is available as an additional accessory for use with LG's SmartThinQ app on a smart device.

#### Condensate

The unit is designed for gravity draining of condensate.

Figure 242: Multi F Multi Position Air Handling Unit Indoor Unit.



## Features

- Inverter (Variable speed fan)
- Control lock function
- Auto operation
- Dehumidifying function
- Two thermistor control
- Group control
- Optional accessory electric heater
- Self-diagnostics function
- Optional accessory dry contact for third party thermostat
- Wired controller ordered separately
- Constant CFM ECM fan

Table 108: Multi F Multi Position Air Handling Indoor Unit NA Chassis General Data.

Model Name	KNMLB121A	KNMLB181A	KNMLB241A
Nominal Cooling Capacity (Btu/h) <sup>1</sup>	12,000	18,000	24,000
Nominal Heating Capacity (Btu/h) <sup>1</sup>	15,000	20,000	27,000
<i>Operating Range</i>			
Cooling (°F WB)	57-77	57-77	57-77
Heating (°F DB)	59-81	59-81	59-81
<i>Fan</i>			
Type	Sirocco	Sirocco	Sirocco
Motor Output (W) x Qty.	235 x 1	235 x 1	235 x 1
Motor/Drive	ECM / Direct	ECM / Direct	ECM / Direct
Airflow Rate CFM (H/M/L)	500 / 460 / 420	600 / 510 / 440	800 / 700 / 580
Maximum External Static Pressure (in. WG)	1.0	1.0	1.0
<i>Unit Data</i>			
Refrigerant Type <sup>2</sup>	R32	R32	R32
Refrigerant Control	EEV	EEV	EEV
Power Supply V, Ø, Hz <sup>3</sup>	208-230, 1, 60	208-230, 1, 60	208-230, 1, 60
Rated Amps (A)	2.6	2.6	2.6
Sound Pressure Level dB(A) (H/M/L) <sup>4</sup> at 0.3"WG ESP	34 / 31 / 28	35 / 32 / 29	36 / 33 / 29
Dimensions (W x H x D, in.)	18 x 48-21/32 x 21-3/8	18 x 48-21/32 x 21-3/8	18 x 48-21/32 x 21-3/8
Net Weight (lbs.)	113	113	113
Shipping Weight (lbs.)	123	123	123
Power Wiring Cable (No. x AWG) <sup>5</sup>	3 x 14	3 x 14	3 x 14
Communications Wiring Cable (No. x AWG) <sup>5</sup>	2 x 18	2 x 18	2 x 18
Heat Exchanger (Row x Column x Fin / inch) x Number	2 x 24 x 18	2 x 24 x 18	2 x 24 x 18
Dehumidification Rate (pts./hr)	1.27	2.75	4.23
<i>Pipe Size</i>			
Liquid (in.)	1/4	1/4	1/4
Vapor (in.)	3/8	1/2	1/2
<i>Connection Size</i>			
Liquid (in.)	1/4	1/4	1/4
Vapor (in.)	3/8	1/2	1/2
Primary Drain I.D. (in.)	3/4 FPT	3/4 FPT	3/4 FPT
Secondary Drain I.D. (in.)	3/4 FPT	3/4 FPT	3/4 FPT

<sup>1</sup>Nominal capacity is rated 0 ft. above sea level with corresponding refrigerant piping length in accordance with standard length of each outdoor unit and a 0 ft. level difference between outdoor and indoor units. All capacities are net with a combination ratio between 95 – 105%.

Nominal cooling capacity rating obtained with air entering the indoor unit at 80°F dry bulb (DB) and 67°F wet bulb (WB) and outdoor ambient conditions of 95°F dry bulb (DB) and 75°F wet bulb (WB).  
Nominal heating capacity rating obtained with air entering the indoor unit at 70°F dry bulb (DB) and 60°F wet bulb (WB) and outdoor ambient conditions of 47°F dry bulb (DB) and 43°F wet bulb (WB).

<sup>2</sup>This unit comes with a dry helium charge.

<sup>3</sup>Acceptable operating voltage: 187V-253V.

<sup>4</sup>Sound pressure levels are tested in an anechoic chamber under ISO Standard 3745 and are the same in both cooling and heating mode. These values can increase due to ambient conditions during operation.

<sup>5</sup>The power wiring and the communication wiring from the outdoor unit to the indoor unit, or from the branch distribution unit to the indoor unit is field supplied and must be stranded, shielded or unshielded (if shielded, it must be grounded to the chassis of the outdoor unit only). All wiring must comply with applicable local and national codes.

# MULTI POSITION AIR HANDLING UNIT INDOOR UNITS

MULTI F  
MULTI F MAX

## General Data / Specifications

Table 109: Multi F Multi Position Air Handling Indoor Unit NB Chassis General Data.

Model Name	KNMLB301A	KNMLB361A
Nominal Cooling Capacity (Btu/h) <sup>1</sup>	30,000	36,000
Nominal Heating Capacity (Btu/h) <sup>1</sup>	34,000	40,000
<i>Operating Range</i>		
Cooling (°F WB)	57-77	57-77
Heating (°F DB)	59-81	59-81
<i>Fan</i>		
Type	Sirocco	Sirocco
Motor Output (W) x Qty.	554 x 1	554 x 1
Motor/Drive	ECM / Direct	ECM / Direct
Airflow Rate CFM (H/M/L)	875 / 750 / 630	1050 / 980 / 900
Maximum External Static Pressure (in. WG)	1.0	1.0
<i>Unit Data</i>		
Refrigerant Type <sup>2</sup>	R32	R32
Refrigerant Control	EEV	EEV
Power Supply V, Ø, Hz <sup>3</sup>	208-230, 1, 60	208-230, 1, 60
Rated Amps (A)	4.8	4.8
Sound Pressure Level dB(A) (H/M/L) <sup>4</sup> at 0.3"WG ESP	40 / 37 / 35	40 / 37 / 35
Dimensions (W x H x D, in.)	21 x 55-3/16 x 21-3/8	21 x 55-3/16 x 21-3/8
Net Weight (lbs.)	134	134
Shipping Weight (lbs.)	147	147
Power Wiring Cable (No. x AWG) <sup>5</sup>	3 x 14	3 x 14
Communications Wiring Cable (No. x AWG) <sup>5</sup>	2 x 18	2 x 18
Heat Exchanger (Row x Column x Fin / inch) x Number	2 x 30 x 18	2 x 30 x 18
Dehumidification Rate (pts./hr)	5.6	7.17
<i>Pipe Size</i>		
Liquid (in.)	3/8	3/8
Vapor (in.)	5/8	5/8
<i>Connection Size</i>		
Liquid (in.)	3/8	3/8
Vapor (in.)	5/8	5/8
Primary Drain I.D. (in.)	3/4 FPT	3/4 FPT
Secondary Drain I.D. (in.)	3/4 FPT	3/4 FPT

<sup>1</sup>Nominal capacity is rated 0 ft. above sea level with corresponding refrigerant piping length in accordance with standard length of each outdoor unit and a 0 ft. level difference between outdoor and indoor units. All capacities are net with a combination ratio between 95 – 105%.

Nominal cooling capacity rating obtained with air entering the indoor unit at 80°F dry bulb (DB) and 67°F wet bulb (WB) and outdoor ambient conditions of 95°F dry bulb (DB) and 75°F wet bulb (WB).  
Nominal heating capacity rating obtained with air entering the indoor unit at 70°F dry bulb (DB) and 60°F wet bulb (WB) and outdoor ambient conditions of 47°F dry bulb (DB) and 43°F wet bulb (WB).

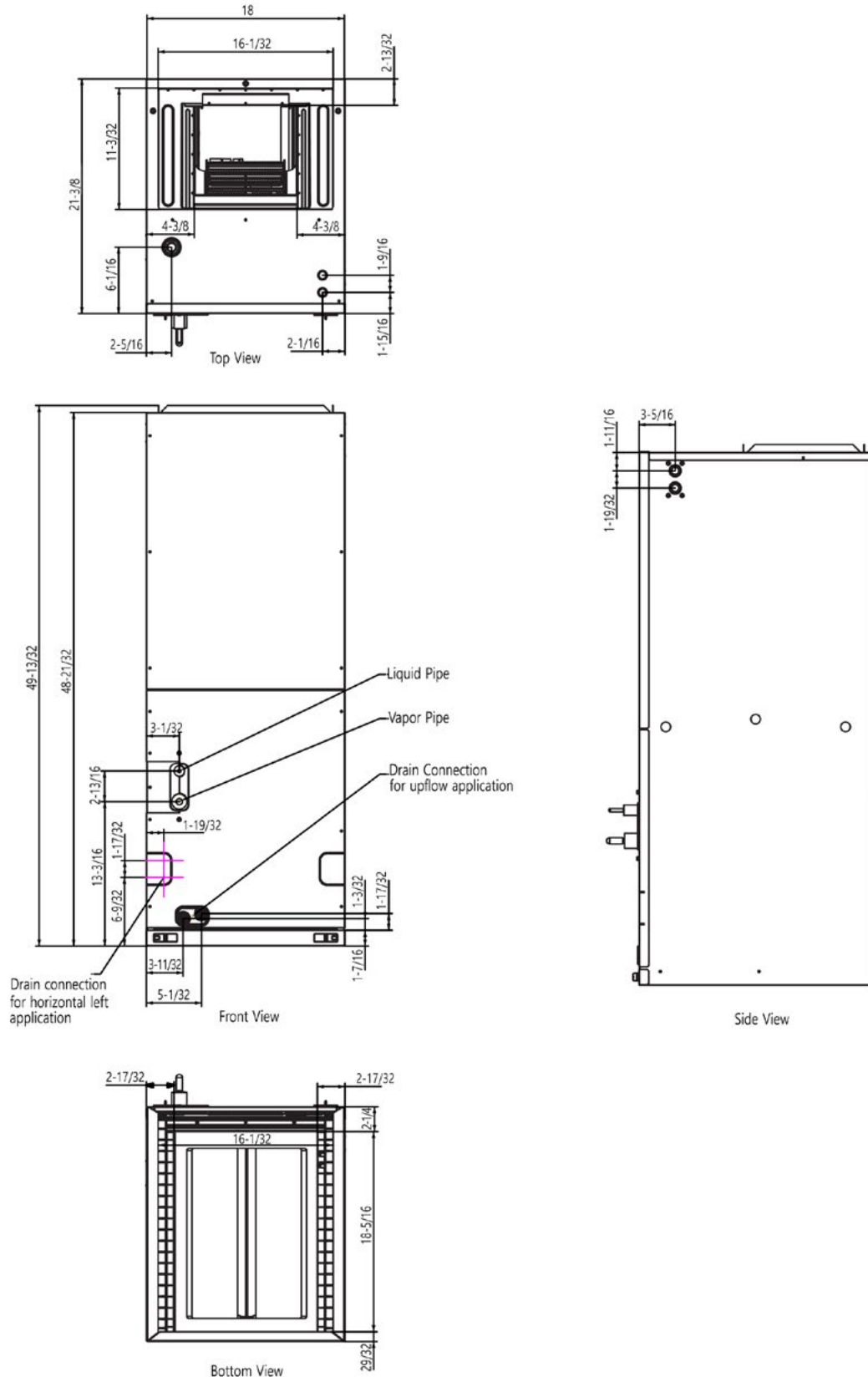
<sup>2</sup>This unit comes with a dry helium charge.

<sup>3</sup>Acceptable operating voltage: 187V-253V.

<sup>4</sup>Sound pressure levels are tested in an anechoic chamber under ISO Standard 3745 and are the same in both cooling and heating mode. These values can increase due to ambient conditions during operation.

<sup>5</sup>The power wiring and the communication wiring from the outdoor unit to the indoor unit, or from the branch distribution unit to the indoor unit is field supplied and must be stranded, shielded or unshielded (if shielded, it must be grounded to the chassis of the outdoor unit only). All wiring must comply with applicable local and national codes.

Figure 243: Multi Position Air Handling Unit Dimensions KNMLB121A, KNMLB181A, KNMLB241A.

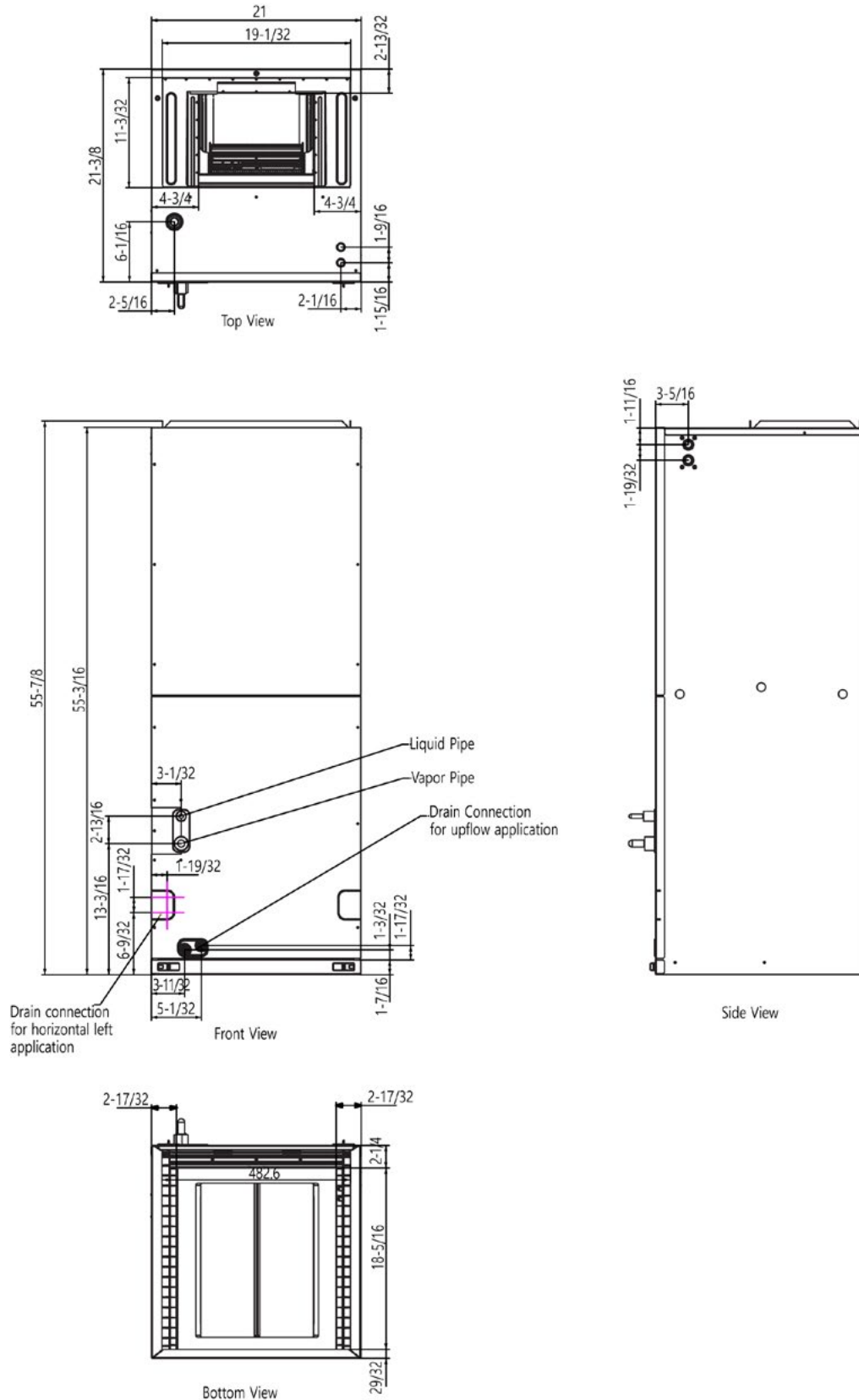


# MULTI POSITION AIR HANDLING UNIT INDOOR UNITS

MULTI F  
MULTI F MAX

## Dimensions

Figure 244: Multi Position Air Handling Unit Dimensions, KNMLB301A, KNMLB361A.



# MULTI POSITION AIR HANDLING UNIT INDOOR UNITS

## Cooling Capacity Table

Table 110: Multi F Multi Position Air Handling Indoor Units Cooling Capacity Table.

Model No. / Nominal Capacity of Indoor Unit (Btu/h)	Outdoor Air Temp. (°F DB)	Indoor Air Temp. °F DB / °F WB											
		68 / 57		73 / 61		77 / 64		80 / 67		86 / 72		90 / 75	
		TC	SHC	TC	SHC	TC	SHC	TC	SHC	TC	SHC	TC	SHC
KNMLB121A 12,000	-4	11.80	8.12	12.53	8.58	13.26	8.31	13.79	8.48	14.73	8.55	15.46	8.72
	-0.4	11.79	8.17	12.52	8.63	13.26	8.36	13.78	8.53	14.72	8.60	15.45	8.77
	5	11.78	8.24	12.51	8.71	13.24	8.43	13.77	8.61	14.71	8.68	15.44	8.84
	10	11.77	8.31	12.50	8.77	13.23	8.50	13.76	8.68	14.70	8.75	15.43	8.91
	15	11.76	8.37	12.49	8.84	13.22	8.56	13.75	8.74	14.69	8.82	15.42	8.98
	20	11.75	8.44	12.48	8.91	13.21	8.63	13.74	8.81	14.67	8.89	15.40	9.05
	25	11.75	8.50	12.48	8.98	13.20	8.70	13.73	8.88	14.66	8.96	15.39	9.12
	30	11.74	8.57	12.47	9.05	13.19	8.76	13.72	8.95	14.65	9.02	15.38	9.19
	35	11.73	8.63	12.46	9.12	13.18	8.83	13.71	9.02	14.64	9.09	15.37	9.26
	40	11.72	8.70	12.45	9.19	13.17	8.90	13.70	9.08	14.63	9.16	15.36	9.33
	45	11.71	8.76	12.44	9.26	13.16	8.96	13.69	9.15	14.62	9.23	15.35	9.40
	50	11.70	8.83	12.43	9.33	13.15	9.03	13.68	9.22	14.61	9.30	15.33	9.47
	55	11.69	8.89	12.42	9.39	13.14	9.10	13.67	9.29	14.60	9.37	15.32	9.54
	60	11.68	8.96	12.41	9.46	13.13	9.16	13.66	9.35	14.59	9.43	15.31	9.61
	65	11.67	9.02	12.40	9.53	13.12	9.23	13.65	9.42	14.57	9.50	15.30	9.68
	70	11.66	9.09	12.39	9.60	13.11	9.29	13.64	9.49	14.56	9.57	15.29	9.75
	75	11.38	8.94	12.11	9.45	12.83	9.16	13.35	9.36	14.27	9.45	15.00	9.64
	80	11.10	8.78	11.82	9.30	12.55	9.03	13.07	9.23	13.99	9.33	14.71	9.53
	85	10.83	8.62	11.54	9.15	12.26	8.89	12.78	9.10	13.70	9.21	14.42	9.41
	90	10.55	8.46	11.26	8.99	11.98	8.74	12.50	8.96	13.42	9.08	14.13	9.28
95	10.25	8.37	10.96	8.91	11.67	8.68	<b>12.00</b>	<b>8.76</b>	13.10	9.03	13.81	9.24	
100	10.00	8.15	10.71	8.68	11.42	8.47	11.84	8.62	12.85	8.84	13.56	9.05	
105	9.75	7.92	10.46	8.46	11.17	8.26	11.69	8.49	12.60	8.64	13.31	8.86	
110	9.50	7.65	10.21	8.18	10.92	8.01	11.44	8.24	12.35	8.40	13.07	8.62	
115	9.25	7.42	9.96	7.95	10.67	7.80	11.19	8.03	12.10	8.20	12.82	8.42	
118	9.10	7.37	9.81	7.91	10.52	7.76	11.04	7.99	11.95	8.17	12.67	8.40	
122	9.05	7.35	9.76	7.89	10.48	7.74	10.99	7.98	11.90	8.16	12.62	8.39	
KNMLB181A 18,000	-4	17.70	12.85	18.80	13.58	19.89	13.14	20.69	13.42	22.09	13.53	23.19	13.79
	-0.4	17.69	12.93	18.79	13.66	19.88	13.22	20.68	13.50	22.08	13.61	23.18	13.87
	5	17.67	13.04	18.77	13.77	19.87	13.34	20.66	13.62	22.06	13.73	23.16	13.99
	10	17.66	13.14	18.76	13.88	19.85	13.44	20.64	13.73	22.05	13.84	23.14	14.10
	15	17.65	13.25	18.74	13.99	19.84	13.55	20.63	13.83	22.03	13.95	23.12	14.22
	20	17.63	13.35	18.73	14.10	19.82	13.65	20.61	13.94	22.01	14.06	23.11	14.33
	25	17.62	13.45	18.71	14.21	19.81	13.76	20.60	14.05	22.00	14.17	23.09	14.44
	30	17.60	13.56	18.70	14.32	19.79	13.87	20.58	14.16	21.98	14.28	23.07	14.55
	35	17.59	13.66	18.68	14.43	19.78	13.97	20.57	14.27	21.96	14.39	23.05	14.66
	40	17.58	13.76	18.67	14.54	19.76	14.08	20.55	14.37	21.94	14.49	23.04	14.77
	45	17.56	13.87	18.66	14.65	19.75	14.18	20.53	14.48	21.93	14.60	23.02	14.88
	50	17.55	13.97	18.64	14.75	19.73	14.29	20.52	14.59	21.91	14.71	23.00	14.99
	55	17.54	14.07	18.63	14.86	19.72	14.39	20.50	14.69	21.89	14.82	22.98	15.10
	60	17.52	14.17	18.61	14.97	19.70	14.50	20.49	14.80	21.88	14.93	22.97	15.21
	65	17.51	14.27	18.60	15.08	19.69	14.60	20.47	14.91	21.86	15.03	22.95	15.32
	70	17.50	14.38	18.58	15.19	19.67	14.70	20.46	15.01	21.84	15.14	22.93	15.43
	75	17.08	14.14	18.16	14.96	19.24	14.50	20.03	14.81	21.41	14.96	22.50	15.25
	80	16.66	13.90	17.74	14.72	18.82	14.29	19.60	14.61	20.98	14.77	22.06	15.07
	85	16.24	13.64	17.32	14.47	18.40	14.06	19.17	14.39	20.55	14.57	21.63	14.88
	90	15.82	13.39	16.90	14.22	17.97	13.84	18.75	14.17	20.12	14.36	21.20	14.69
95	15.37	13.25	16.44	14.09	17.51	13.73	<b>18.00</b>	<b>13.86</b>	19.65	14.29	20.72	14.62	
100	14.99	12.89	16.06	13.74	17.13	13.40	17.77	13.65	19.28	13.98	20.35	14.32	
105	14.62	12.54	15.69	13.38	16.76	13.08	17.53	13.43	18.90	13.67	19.97	14.02	
110	14.24	12.11	15.32	12.95	16.39	12.67	17.16	13.03	18.53	13.29	19.60	13.64	
115	13.87	11.75	14.94	12.58	16.01	12.34	16.79	12.70	18.15	12.97	19.22	13.33	
118	13.65	11.66	14.72	12.51	15.79	12.27	16.56	12.64	17.93	12.92	19.00	13.29	
122	13.57	11.63	14.64	12.48	15.71	12.25	16.49	12.62	17.85	12.91	18.92	13.28	

TC = Total Capacity (kBtu/h).

SHC: Sensible Heat Capacity (kBtu/h).

Nominal capacity as rated 0 ft. above sea level and a 0 ft. level difference between outdoor and indoor units. Corresponding refrigerant piping length is accordance with standard length of each outdoor unit.

Nominal cooling capacity rating obtained with air entering the indoor unit at 80°F dry bulb (DB) and 67°F wet bulb (WB), and outdoor ambient conditions of 95°F dry bulb (DB) and 75°F wet bulb (WB).

The shaded table columns and rows indicate reference data. When operating at this temperature, these values can be different if the system is not running consistently.

Multi Position Air Handling Unit

# MULTI POSITION AIR HANDLING UNIT INDOOR UNITS

MULTI F  
MULTI F MAX

## Cooling Capacity Table

Table 95: Multi F Multi Position Air Handling Indoor Units Cooling Capacity Table - continued

Model No. / Nominal Capacity of Indoor Unit (Btu/h)	Outdoor Air Temp. (°F DB)	Indoor Air Temp. °F DB / °F WB											
		68 / 57		73 / 61		77 / 64		80 / 67		86 / 72		90 / 75	
		TC	SHC	TC	SHC	TC	SHC	TC	SHC	TC	SHC	TC	SHC
KNMLB241A 24,000	-4	23.60	17.14	25.06	18.10	26.53	17.53	27.58	17.90	29.46	18.05	30.92	18.39
	-0.4	23.58	17.24	25.05	18.21	26.51	17.63	27.57	18.00	29.44	18.15	30.91	18.50
	5	23.56	17.39	25.03	18.37	26.49	17.78	27.55	18.16	29.42	18.31	30.88	18.66
	10	23.55	17.52	25.01	18.51	26.47	17.92	27.53	18.30	29.39	18.46	30.86	18.81
	15	23.53	17.66	24.99	18.66	26.45	18.07	27.50	18.45	29.37	18.60	30.83	18.95
	20	23.51	17.80	24.97	18.80	26.43	18.21	27.48	18.59	29.35	18.75	30.81	19.10
	25	23.49	17.94	24.95	18.95	26.41	18.35	27.46	18.73	29.33	18.89	30.79	19.25
	30	23.47	18.08	24.93	19.09	26.39	18.49	27.44	18.88	29.30	19.04	30.76	19.40
	35	23.46	18.21	24.91	19.24	26.37	18.63	27.42	19.02	29.28	19.18	30.74	19.54
	40	23.44	18.35	24.89	19.38	26.35	18.77	27.40	19.16	29.26	19.33	30.72	19.69
	45	23.42	18.49	24.87	19.53	26.33	18.91	27.38	19.31	29.24	19.47	30.69	19.84
	50	23.40	18.62	24.85	19.67	26.31	19.05	27.36	19.45	29.21	19.61	30.67	19.99
	55	23.38	18.76	24.84	19.82	26.29	19.19	27.34	19.59	29.19	19.76	30.64	20.13
	60	23.37	18.90	24.82	19.96	26.27	19.33	27.32	19.73	29.17	19.90	30.62	20.28
	65	23.35	19.03	24.80	20.10	26.25	19.47	27.29	19.88	29.15	20.04	30.60	20.42
	70	23.33	19.17	24.78	20.25	26.23	19.61	27.27	20.02	29.13	20.19	30.57	20.57
	75	22.77	18.85	24.21	19.94	25.66	19.33	26.70	19.75	28.55	19.94	29.99	20.34
	80	22.21	18.53	23.65	19.63	25.09	19.05	26.13	19.48	27.97	19.69	29.42	20.10
	85	21.65	18.19	23.09	19.30	24.53	18.75	25.57	19.19	27.40	19.43	28.84	19.84
	90	21.09	17.85	22.53	18.96	23.96	18.45	25.00	18.90	26.83	19.15	28.27	19.59
95	20.49	17.66	21.92	18.79	23.35	18.31	<b>24.00</b>	<b>18.48</b>	26.20	19.05	27.63	19.50	
100	19.99	17.19	21.42	18.31	22.85	17.87	23.69	18.19	25.70	18.64	27.13	19.10	
105	19.49	16.71	20.92	17.84	22.35	17.43	23.38	17.91	25.20	18.23	26.63	18.70	
110	18.99	16.14	20.42	17.26	21.85	16.90	22.88	17.37	24.70	17.71	26.13	18.19	
115	18.49	15.66	19.92	16.78	21.35	16.45	22.38	16.93	24.20	17.29	25.63	17.77	
118	18.19	15.55	19.62	16.68	21.05	16.36	22.08	16.86	23.90	17.23	25.33	17.72	
122	18.10	15.51	19.52	16.64	20.95	16.34	21.98	16.83	23.81	17.21	25.23	17.71	
KNMLB301A 30,000	-4	29.50	20.87	31.33	22.03	33.15	21.33	34.48	21.78	36.82	21.97	38.65	22.38
	-0.4	29.48	20.98	31.32	22.17	33.13	21.47	34.47	21.92	36.80	22.10	38.63	22.52
	5	29.45	21.17	31.28	22.37	33.12	21.65	34.43	22.10	36.77	22.30	38.60	22.72
	10	29.43	21.33	31.27	22.53	33.08	21.82	34.40	22.28	36.75	22.47	38.57	22.90
	15	29.42	21.50	31.23	22.72	33.07	22.00	34.38	22.45	36.72	22.65	38.53	23.08
	20	29.38	21.67	31.22	22.90	33.03	22.17	34.35	22.63	36.68	22.82	38.52	23.25
	25	29.37	21.83	31.18	23.07	33.02	22.33	34.33	22.82	36.67	23.00	38.48	23.43
	30	29.33	22.00	31.17	23.25	32.98	22.52	34.30	22.98	36.63	23.18	38.45	23.62
	35	29.32	22.17	31.13	23.42	32.97	22.68	34.28	23.17	36.60	23.35	38.42	23.80
	40	29.30	22.35	31.12	23.60	32.93	22.85	34.25	23.33	36.57	23.53	38.40	23.98
	45	29.27	22.52	31.10	23.78	32.92	23.02	34.22	23.50	36.55	23.70	38.37	24.15
	50	29.25	22.67	31.07	23.95	32.88	23.20	34.20	23.68	36.52	23.88	38.33	24.33
	55	29.23	22.83	31.05	24.13	32.87	23.37	34.17	23.85	36.48	24.05	38.30	24.52
	60	29.20	23.00	31.02	24.30	32.83	23.53	34.15	24.03	36.47	24.23	38.28	24.68
	65	29.18	23.17	31.00	24.48	32.82	23.70	34.12	24.20	36.43	24.40	38.25	24.87
	70	29.17	23.33	30.97	24.65	32.78	23.87	34.10	24.37	36.40	24.58	38.22	25.05
	75	28.47	22.95	30.27	24.28	32.07	23.53	33.38	24.05	35.68	24.28	37.50	24.77
	80	27.77	22.57	29.57	23.90	31.37	23.18	32.67	23.72	34.97	23.97	36.77	24.47
	85	27.07	22.15	28.87	23.50	30.67	22.83	31.95	23.37	34.25	23.65	36.05	24.17
	90	26.37	21.73	28.17	23.08	29.95	22.47	31.25	23.00	33.53	23.32	35.33	23.85
95	25.62	21.50	27.40	22.88	29.18	22.28	<b>30.00</b>	<b>22.50</b>	32.75	23.20	34.53	23.73	
100	24.98	20.93	26.77	22.30	28.55	21.75	29.62	22.15	32.13	22.70	33.92	23.25	
105	24.37	20.35	26.15	21.72	27.93	21.23	29.22	21.80	31.50	22.20	33.28	22.77	
110	23.73	19.65	25.53	21.02	27.32	20.57	28.60	21.15	30.88	21.57	32.67	22.15	
115	23.12	19.07	24.90	20.43	26.68	20.03	27.98	20.62	30.25	21.05	32.03	21.63	
118	22.75	18.93	24.53	20.30	26.32	19.92	27.60	20.52	29.88	20.98	31.67	21.58	
122	22.62	18.88	24.40	20.27	26.18	19.88	27.48	20.48	29.75	20.95	31.53	21.57	

TC = Total Capacity (kBtu/h).

SHC: Sensible Heat Capacity (kBtu/h).

Nominal capacity as rated 0 ft. above sea level and a 0 ft. level difference between outdoor and indoor units. Corresponding refrigerant piping length is accordance with standard length of each outdoor unit.

Nominal cooling capacity rating obtained with air entering the indoor unit at 80°F dry bulb (DB) and 67°F wet bulb (WB), and outdoor ambient conditions of 95°F dry bulb (DB) and 75°F wet bulb (WB).

The shaded table columns and rows indicate reference data. When operating at this temperature, these values can be different if the system is not running consistently.

Table 95: Multi F Multi Position Air Handling Indoor Units Cooling Capacity Table - continued

Model No. / Nominal Capacity of Indoor Unit (Btu/h)	Outdoor Air Temp. (°F DB)	Indoor Air Temp. °F DB / °F WB											
		68 / 57		73 / 61		77 / 64		80 / 67		86 / 72		90 / 75	
		TC	SHC	TC	SHC	TC	SHC	TC	SHC	TC	SHC	TC	SHC
KNMLB361A 36,000	-4	35.40	25.39	37.60	26.81	39.78	25.96	41.38	26.51	44.18	26.73	46.38	27.24
	-0.4	35.38	25.53	37.58	26.97	39.76	26.12	41.36	26.67	44.16	26.89	46.36	27.40
	5	35.34	25.76	37.54	27.22	39.74	26.35	41.32	26.89	44.12	27.14	46.32	27.64
	10	35.32	25.96	37.52	27.42	39.70	26.55	41.28	27.12	44.10	27.34	46.28	27.87
	15	35.30	26.16	37.48	27.64	39.68	26.77	41.26	27.32	44.06	27.56	46.24	28.09
	20	35.26	26.37	37.46	27.87	39.64	26.97	41.22	27.54	44.02	27.77	46.22	28.29
	25	35.24	26.57	37.42	28.07	39.62	27.18	41.20	27.77	44.00	27.99	46.18	28.52
	30	35.20	26.77	37.40	28.29	39.58	27.40	41.16	27.97	43.96	28.21	46.14	28.74
	35	35.18	26.97	37.36	28.50	39.56	27.60	41.14	28.19	43.92	28.41	46.10	28.96
	40	35.16	27.20	37.34	28.72	39.52	27.81	41.10	28.39	43.88	28.64	46.08	29.19
	45	35.12	27.40	37.32	28.94	39.50	28.01	41.06	28.60	43.86	28.84	46.04	29.39
	50	35.10	27.58	37.28	29.14	39.46	28.23	41.04	28.82	43.82	29.06	46.00	29.61
	55	35.08	27.79	37.26	29.37	39.44	28.43	41.00	29.02	43.78	29.27	45.96	29.83
	60	35.04	27.99	37.22	29.57	39.40	28.64	40.98	29.25	43.76	29.49	45.94	30.04
	65	35.02	28.19	37.20	29.79	39.38	28.84	40.94	29.45	43.72	29.69	45.90	30.26
	70	35.00	28.39	37.16	30.00	39.34	29.04	40.92	29.65	43.68	29.92	45.86	30.48
	75	34.16	27.93	36.32	29.55	38.48	28.64	40.06	29.27	42.82	29.55	45.00	30.14
	80	33.32	27.46	35.48	29.08	37.64	28.21	39.20	28.86	41.96	29.16	44.12	29.77
	85	32.48	26.95	34.64	28.60	36.80	27.79	38.34	28.43	41.10	28.78	43.26	29.41
	90	31.64	26.45	33.80	28.09	35.94	27.34	37.50	27.99	40.24	28.37	42.40	29.02
95	30.74	26.16	32.88	27.85	35.02	27.12	<b>36.00</b>	<b>27.38</b>	39.30	28.23	41.44	28.88	
100	29.98	25.47	32.12	27.14	34.26	26.47	35.54	26.95	38.56	27.62	40.70	28.29	
105	29.24	24.76	31.38	26.43	33.52	25.84	35.06	26.53	37.80	27.01	39.94	27.70	
110	28.48	23.91	30.64	25.57	32.78	25.03	34.32	25.74	37.06	26.24	39.20	26.95	
115	27.74	23.20	29.88	24.87	32.02	24.38	33.58	25.09	36.30	25.62	38.44	26.33	
118	27.30	23.04	29.44	24.70	31.58	24.24	33.12	24.97	35.86	25.53	38.00	26.26	
122	27.14	22.98	29.28	24.66	31.42	24.20	32.98	24.93	35.70	25.49	37.84	26.24	

TC = Total Capacity (kBtu/h).

SHC: Sensible Heat Capacity (kBtu/h).

Nominal capacity as rated 0 ft. above sea level and a 0 ft. level difference between outdoor and indoor units. Corresponding refrigerant piping length is accordance with standard length of each outdoor unit.

Nominal cooling capacity rating obtained with air entering the indoor unit at 80°F dry bulb (DB) and 67°F wet bulb (WB), and outdoor ambient conditions of 95°F dry bulb (DB) and 75°F wet bulb (WB).

The shaded table columns and rows indicate reference data. When operating at this temperature, these values can be different if the system is not running consistently.

# MULTI POSITION AIR HANDLING UNIT INDOOR UNITS

MULTI F  
MULTI F MAX

## Heating Capacity Table

Table 111: Multi F Multi Position Air Handling Indoor Units Heating Capacity Table.

Model No. / Nominal Capacity of Indoor Unit (Btu/h)	Outdoor Air Temp.		Indoor Air Temp. °F DB					
	°F DB	°F WB	61	64	68	70	72	75
			TC	TC	TC	TC	TC	TC
KNMLB121A 12,000	-13	-13.4	2.9	2.3	2.5	2.5	2.6	2.4
	-4	-4.4	6.2	5.7	5.7	5.6	5.6	5.3
	0	-0.4	7.7	7.2	7.1	7.0	6.9	6.6
	5	4.5	9.3	8.9	8.7	8.5	8.4	8.1
	10	9	10.3	9.9	9.6	9.5	9.3	9.0
	17	15	11.3	10.9	10.6	10.4	10.3	9.9
	20	19	12.0	11.6	11.2	11.0	10.8	10.4
	25	23	13.0	12.6	12.2	11.9	11.7	11.3
	30	28	13.9	13.5	13.0	12.8	12.6	12.2
	35	32	14.9	14.4	13.9	13.6	13.4	13.0
	40	36	15.3	14.8	14.4	14.1	13.9	13.4
	45	41	15.8	15.5	15.0	14.8	14.6	14.0
	47	43	16.1	15.7	15.3	<b>15.00</b>	14.8	14.3
	50	46	16.1	15.8	15.4	15.2	15.0	14.5
	55	51	16.2	15.9	15.6	15.4	15.3	14.8
	60	56	16.3	16.1	15.9	15.7	15.6	15.2
63	59	16.3	16.1	16.0	15.9	15.8	15.4	
68	64	16.4	16.2	16.1	16.1	16.0	15.7	
KNMLB181A 18,000	-13	-13.4	3.1	2.5	2.7	2.7	2.8	2.6
	-4	-4.4	6.9	6.3	6.3	6.3	6.2	5.9
	0	-0.4	8.6	8.1	8.0	7.9	7.8	7.5
	5	4.5	10.7	10.2	9.9	9.8	9.7	9.3
	10	9	12.0	11.6	11.2	11.0	10.9	10.5
	17	15	13.5	13.0	12.6	12.4	12.2	11.8
	20	19	14.4	14.0	13.5	13.2	13.0	12.5
	25	23	15.9	15.4	14.9	14.6	14.4	13.8
	30	28	17.4	16.9	16.3	16.0	15.8	15.2
	35	32	18.9	18.3	17.7	17.4	17.1	16.5
	40	36	19.8	19.3	18.6	18.3	18.1	17.4
	45	41	21.0	20.5	19.9	19.5	19.3	18.6
	47	43	21.4	20.9	20.3	<b>20.00</b>	19.7	19.0
	50	46	21.5	21.0	20.5	20.2	20.0	19.3
	55	51	21.6	21.2	20.8	20.6	20.4	19.8
	60	56	21.7	21.4	21.1	21.0	20.8	20.3
63	59	21.7	21.5	21.3	21.2	21.1	20.6	
68	64	21.8	21.6	21.5	21.4	21.3	20.9	

TC = Total Capacity (kBtu/h).

Nominal capacity as rated 0 ft. above sea level and a 0 ft. level difference between outdoor and indoor units. Corresponding refrigerant piping length is accordance with standard length of each outdoor unit. Nominal heating capacity rating obtained with air entering the indoor unit at 70°F dry bulb (DB) and 60°F wet bulb (WB), and outdoor ambient conditions of 47°F dry bulb (DB) and 43°F wet bulb (WB).

# MULTI POSITION AIR HANDLING UNIT INDOOR UNITS

## Heating Capacity Table

Table 96: Multi F Multi Position Air Handling Indoor Units Heating Capacity Table - continued

Model No. / Nominal Capacity of Indoor Unit (Btu/h)	Outdoor Air Temp.		Indoor Air Temp. °F DB					
	°F DB	°F WB	61	64	68	70	72	75
			TC	TC	TC	TC	TC	TC
KNMLB241A 24,000	-13	-13.4	4.5	3.7	4.0	4.0	4.1	3.8
	-4	-4.4	10.0	9.2	9.2	9.1	9.0	8.6
	0	-0.4	12.5	11.7	11.5	11.4	11.2	10.8
	5	4.5	15.3	14.6	14.3	14.0	13.9	13.3
	10	9	17.1	16.5	16.0	15.7	15.5	14.9
	17	15	19.1	18.4	17.8	17.5	17.2	16.6
	20	19	20.3	19.6	19.0	18.6	18.3	17.6
	25	23	22.2	21.5	20.8	20.4	20.1	19.3
	30	28	24.1	23.4	22.6	22.1	21.8	21.0
	35	32	26.0	25.2	24.3	23.9	23.5	22.7
	40	36	27.0	26.3	25.4	25.0	24.6	23.8
	45	41	28.4	27.7	26.9	26.4	26.1	25.1
	47	43	28.9	28.3	27.5	<b>27.00</b>	26.6	25.7
	50	46	29.0	28.4	27.7	27.3	27.0	26.1
	55	51	29.1	28.7	28.1	27.8	27.5	26.7
	60	56	29.3	28.9	28.5	28.3	28.1	27.4
63	59	29.4	29.0	28.8	28.6	28.4	27.8	
68	64	29.4	29.2	29.0	28.9	28.8	28.2	
KNMLB301A 30,000	-13	-13.4	12.0	10.8	10.9	10.9	10.8	10.3
	-4	-4.4	18.9	18.5	17.9	17.6	17.4	16.8
	0	-0.4	19.8	19.3	18.8	18.5	18.2	17.6
	5	4.5	20.9	20.4	19.9	19.5	19.3	18.6
	10	9	22.5	22.0	21.4	21.0	20.7	20.0
	17	15	24.6	24.1	23.4	23.0	22.7	21.9
	20	19	25.8	25.2	24.5	24.1	23.8	22.9
	25	23	27.8	27.1	26.4	25.9	25.6	24.7
	30	28	29.7	29.1	28.2	27.8	27.4	26.4
	35	32	31.7	31.0	30.1	29.6	29.2	28.1
	40	36	33.6	32.9	32.0	31.4	31.0	29.9
	45	41	35.6	34.8	33.8	33.3	32.8	31.6
	47	43	36.4	35.6	34.6	<b>34.00</b>	33.5	32.3
	50	46	36.5	35.8	34.9	34.4	34.0	32.8
	55	51	36.7	36.1	35.4	35.0	34.7	33.6
	60	56	36.9	36.4	35.9	35.6	35.4	34.5
63	59	37.0	36.6	36.2	36.0	35.8	35.0	
68	64	37.1	36.7	36.6	36.4	36.2	35.5	

Multi Position Air Handling Unit

TC = Total Capacity (kBtu/h).

Nominal capacity as rated 0 ft. above sea level and a 0 ft. level difference between outdoor and indoor units. Corresponding refrigerant piping length is accordance with standard length of each outdoor unit. Nominal heating capacity rating obtained with air entering the indoor unit at 70°F dry bulb (DB) and 60°F wet bulb (WB), and outdoor ambient conditions of 47°F dry bulb (DB) and 43°F wet bulb (WB).

Table 96: Multi F Multi Position Air Handling Indoor Units Heating Capacity Table - continued

Model No. / Nominal Capacity of Indoor Unit (Btu/h)	Outdoor Air Temp.		Indoor Air Temp. °F DB					
	°F DB	°F WB	61	64	68	70	72	75
			TC	TC	TC	TC	TC	TC
KNMLB361A 36,000	-13	-13.4	15.0	13.5	13.7	13.6	13.5	12.8
	-4	-4.4	23.6	23.0	22.4	22.0	21.7	20.9
	0	-0.4	24.7	24.1	23.5	23.1	22.8	21.9
	5	4.5	26.1	25.5	24.8	24.4	24.1	23.2
	10	9	28.1	27.4	26.7	26.2	25.9	24.9
	17	15	30.7	30.0	29.2	28.7	28.3	27.3
	20	19	31.9	31.2	30.3	29.8	29.4	28.4
	25	23	33.9	33.2	32.2	31.7	31.3	30.2
	30	28	36.0	35.2	34.2	33.6	33.2	31.9
	35	32	38.0	37.1	36.1	35.5	35.0	33.7
	40	36	40.0	39.1	38.0	37.4	36.9	35.5
	45	41	42.0	41.1	39.9	39.2	38.7	37.3
	47	43	42.8	41.9	40.7	<b>40.00</b>	39.5	38.0
	50	46	42.9	42.1	41.0	40.4	40.0	38.6
	55	51	43.1	42.4	41.7	41.2	40.8	39.6
	60	56	43.4	42.8	42.3	41.9	41.6	40.6
63	59	43.5	43.0	42.6	42.3	42.1	41.1	
68	64	43.6	43.2	43.0	42.8	42.6	41.7	

TC = Total Capacity (kBtu/h).

Nominal capacity as rated 0 ft. above sea level and a 0 ft. level difference between outdoor and indoor units. Corresponding refrigerant piping length is accordance with standard length of each outdoor unit. Nominal heating capacity rating obtained with air entering the indoor unit at 70°F dry bulb (DB) and 60°F wet bulb (WB), and outdoor ambient conditions of 47°F dry bulb (DB) and 43°F wet bulb (WB).

Table 112: Air Filter Static Pressure Drop Factors.

Capacity (kBtu/h [tons])	Flow Rate (CFM)	Static Pressure Drop (in wg)
12 (1.0)	High (500)	-0.06
	Middle(460)	-0.06
	Low (420)	-0.06
18 (1.5)	High (600)	-0.06
	Middle(510)	-0.06
	Low (440)	-0.06
24 (2.0)	High (800)	-0.06
	Middle(700)	-0.06
	Low (580)	-0.06
30 (2.5)	High (875)	-0.16
	Middle(750)	-0.16
	Low (630)	-0.16
36 (3.0)	High (1,050)	-0.16
	Middle(980)	-0.16
	Low (900)	-0.16

Include -0.04 in wg pressure drop for MPAHU in downflow orientation.

Table 113: Minimum Airflow (CFM) by Heater Capacity

Capacity (kBtu/h [tons])	Heater Capacity kW					
	3	5	8	10	15	20
12 (1.0)	420	420	420	Not Available	Not Available	Not Available
18 (1.5)	440	440	440	440	Not Available	Not Available
24 (2.0)	580	580	580	580	Not Available	Not Available
30 (2.5)	630	630	630	630	Not Available	Not Available
36 (3.0)	900	900	900	900	900	Not Available

### ⚠ WARNING

⊘ Do not operate with less than the minimum airflow. If an airflow is used below the minimum, there is a risk of fire, which will lead to physical injury or death

### NOTICE

⊘ Do not operate with less than the minimum airflow. If an airflow is used below the minimum, there is a risk of damage to the product.

These MPAHUs are constant air volume (CAV) units and do not require any field adjustment to change ESP settings.

Table 114: Electric Heater Static Pressure Drop Factors.

Heater Capacity	Static Pressure Drop (in. wg)
0	0
3	-0.01
5	-0.01
8	-0.02
10	-0.02
15	-0.03

Include -0.04 in wg pressure drop for MPAHU in downflow orientation.

# MULTI POSITION AIR HANDLING UNIT INDOOR UNITS

MULTI F  
MULTI F MAX

## Heater Capacities

Table 115: Optional Electric Heater Capacities.

Heater Capacity (kW)	Model Number
3	ANEH033C1
5	ANEH053C1
8	ANEH083C2
10	ANEH103C2
15	ANEH153C3

Figure 245: Typical Multi Position Air Handling Unit Optional Electric Heater Accessory.

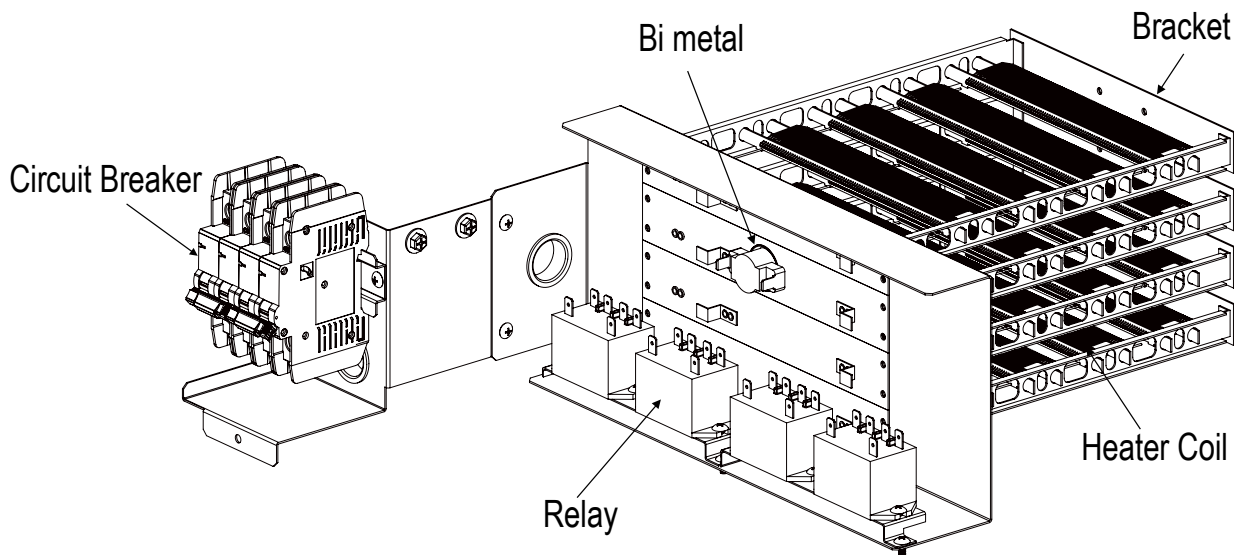
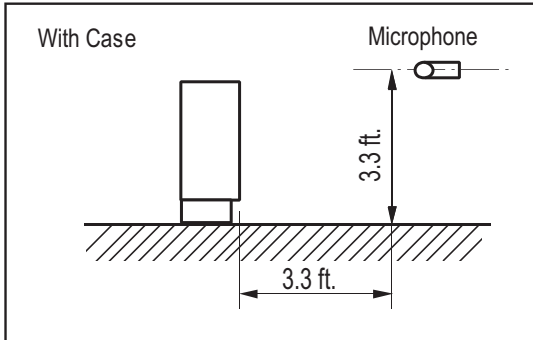


Table 116: Electric Heater Compatibility

VAHU Model Number and Capacity (MBh)	Model Number / Heater Capacity kW					
	ANEH033C1 (3kW)	ANEH053C1 (5kW)	ANEH083C2 (8kW)	ANEH103C2 (10kW)	ANEH153C3 (15kW)	ANEH203C3 (20kW)
KNMLB121A (12)	√	√	√	X	X	X
KNMLB181A (18)	√	√	√	√	X	X
KNMLB241A (24)	√	√	√	√	X	X
KNMLB301A (30)	√	√	√	√	X	X
KNMLB361A (36)	√	√	√	√	√	X

√ = Compatible X = Not Compatible

Figure 246: Sound Pressure Level Measurement Location.



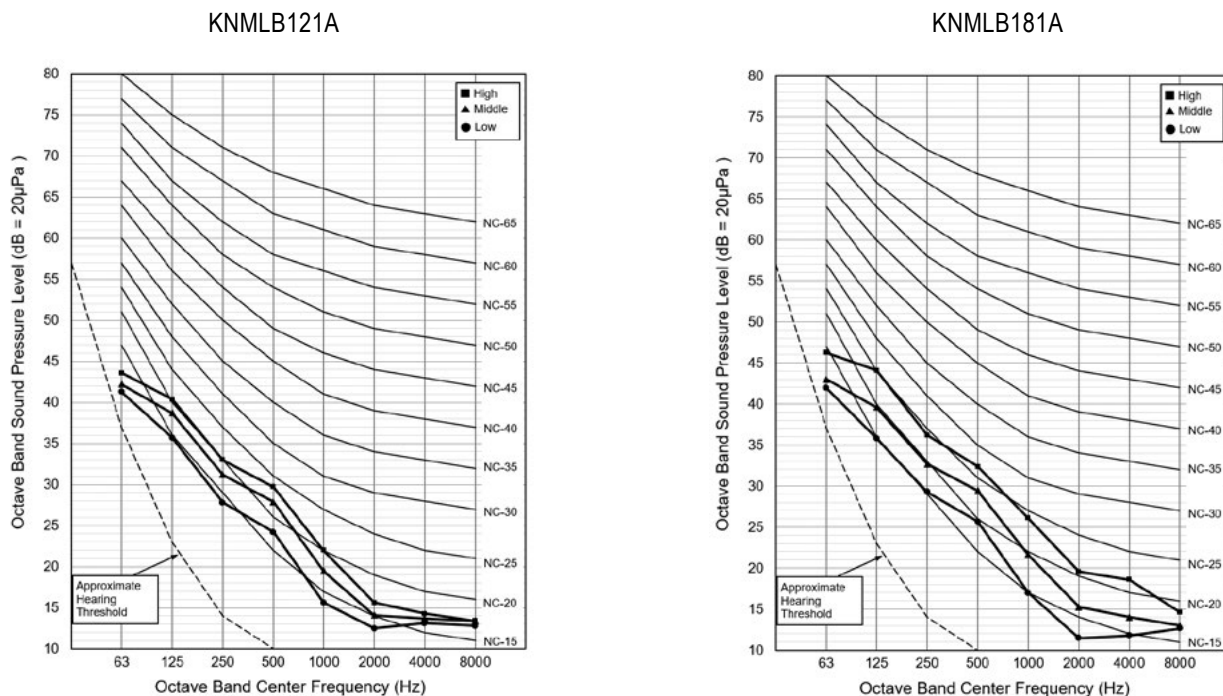
- Measurement taken 3.3' away from the unit.
- Sound pressure levels are measured in dB(A).
- Sound pressure levels are tested in an anechoic chamber under ISO Standard 3745.
- Operating Conditions:  
Power source: 220V/60 Hz.
- Sound level will vary depending on a range of factors including the construction (acoustic absorption coefficient) of a particular room in which the unit was installed.

Table 117: Multi Position Air Handling Unit Sound Pressure Levels (dB[A]).

Model No.	Sound Pressure Levels (dB[A]) (Cooling and Heating)		
	High Fan Speed	Medium Fan Speed	Low Fan Speed
KNMLB121A	34	31	28
KNMLB181A	35	32	29
KNMLB241A	36	33	29
KNMLB301A	40	37	35
KNMLB361A	40	37	35

KNMLB361A

Figure 247: Sound Pressure Level Diagrams.



# MULTI POSITION AIR HANDLING UNIT INDOOR UNITS

MULTI F  
MULTI F MAX

## Acoustic Data

Figure 248: Sound Pressure Level Diagrams - continued.

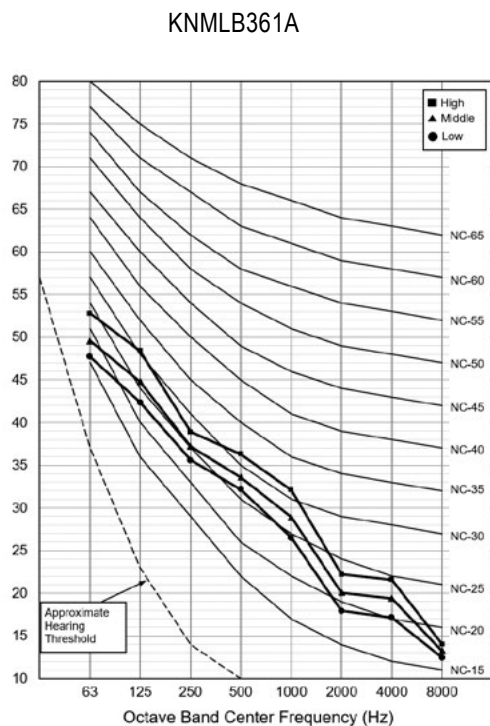
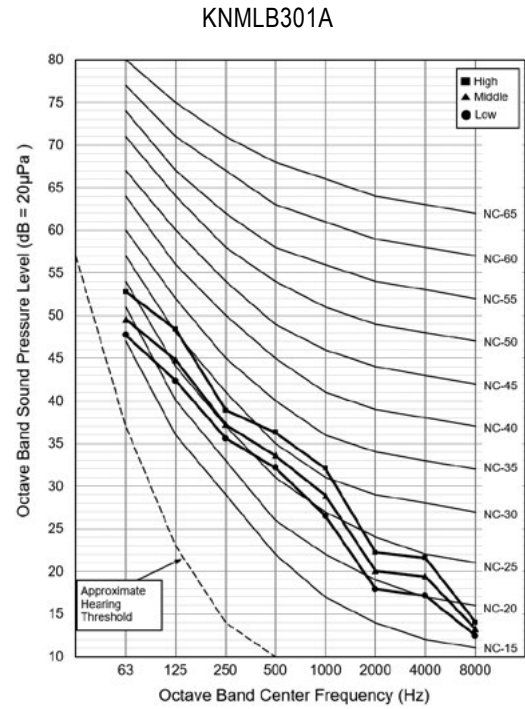
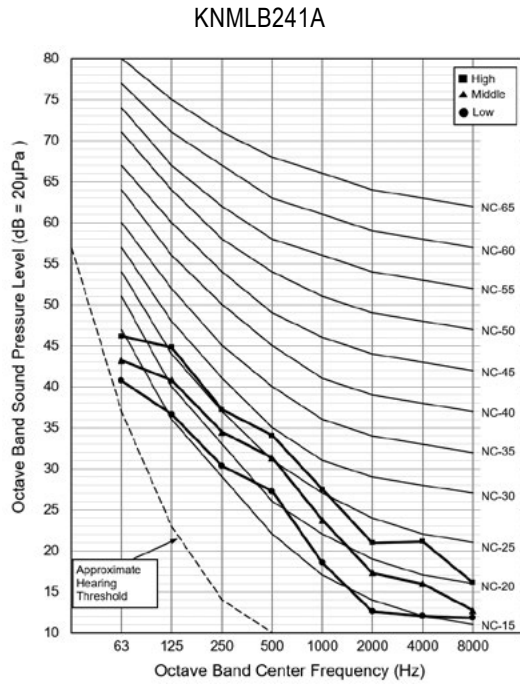


Figure 249: Multi Position Air Handling Indoor Unit Refrigerant Flow Diagram.

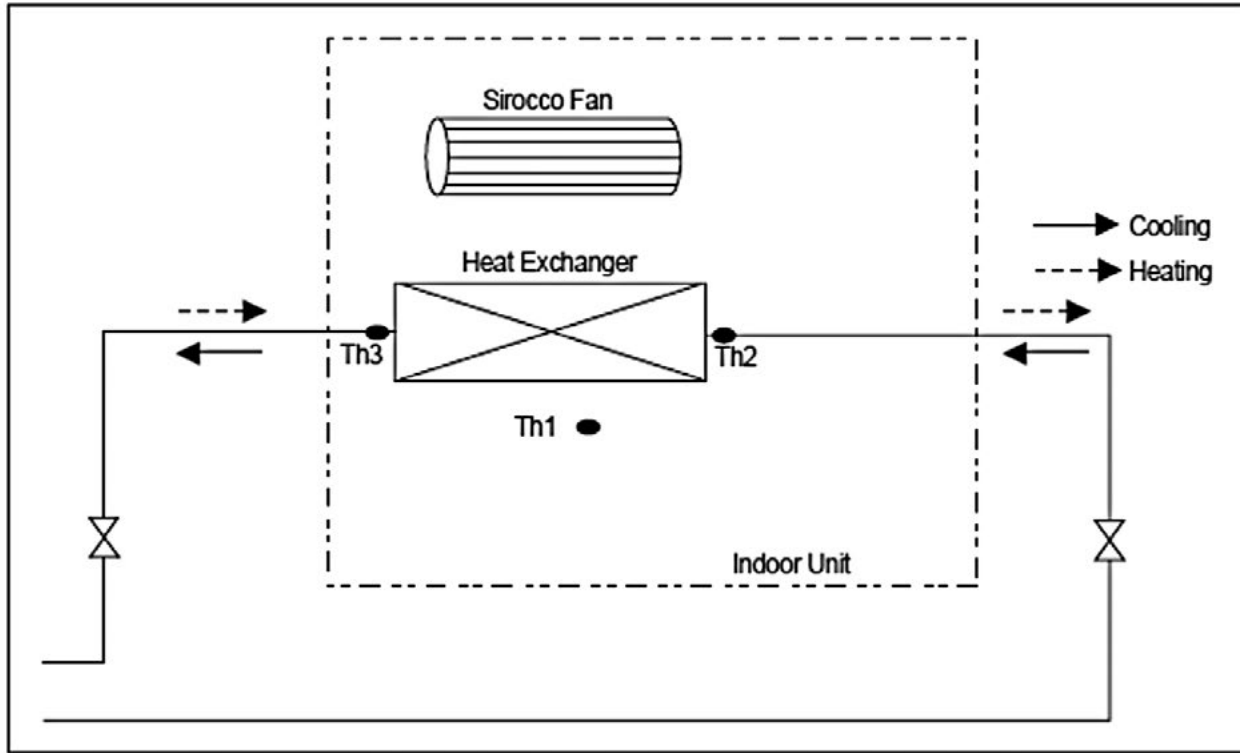


Table 118: Multi Position Air Handling Indoor Unit Refrigerant Pipe Sizes and Connection Sizes.

Model No.	Piping Size		Connection Port Size	
	Liquid (inch)	Vapor (inch)	Liquid (inch)	Vapor (inch)
KNMLB121A	1/4	3/8	1/4	3/8
KNMLB181A	1/4	1/2	1/4	1/2
KNMLB241A	1/4	1/2	1/4	1/2
KNMLB301A	3/8	5/8	3/8	5/8
KNMLB361A	3/8	5/8	3/8	5/8

Table 119: Multi Position Air-Handling Indoor Unit Thermistor Details.

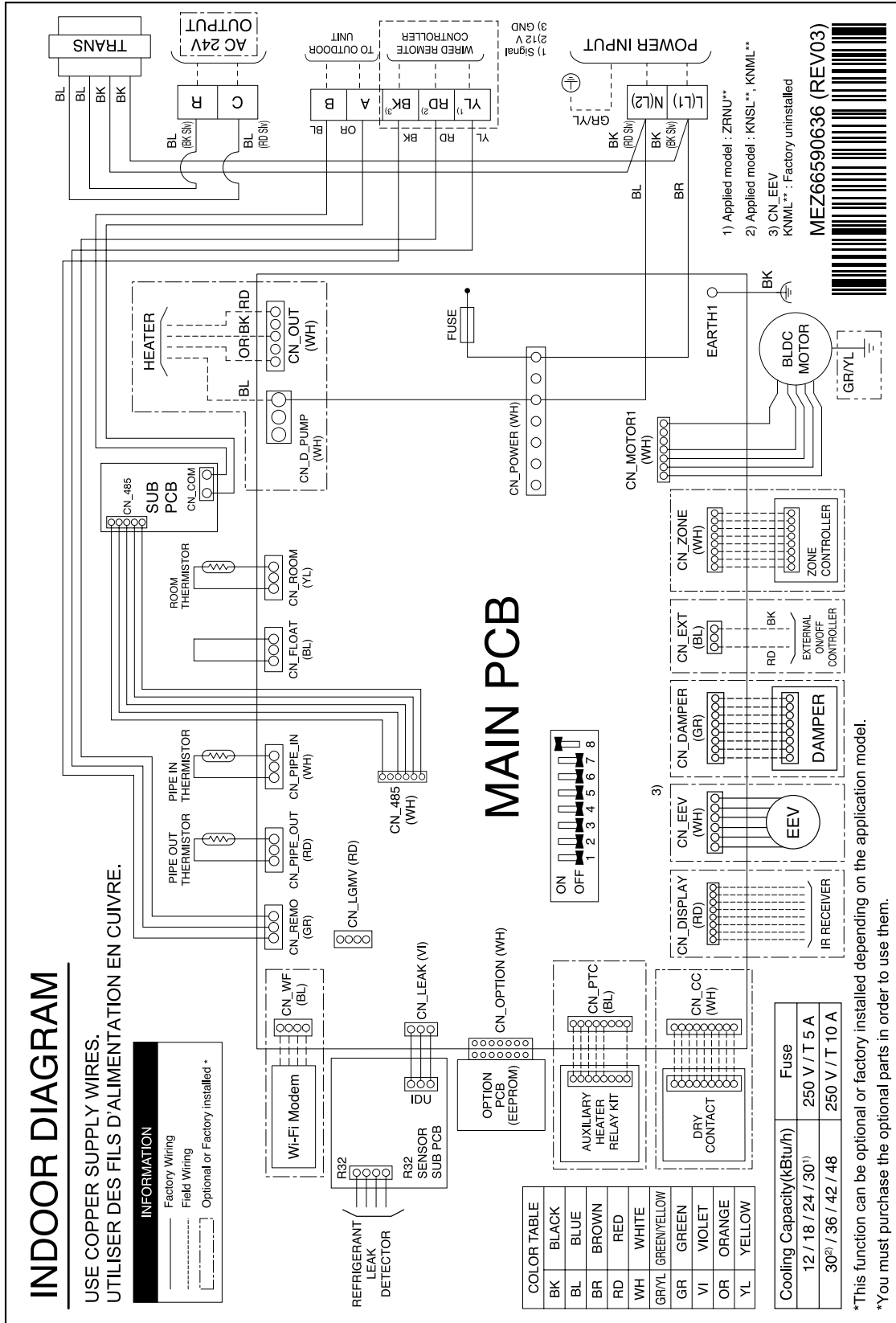
Thermistor Location	Thermistor Description (Based on Cooling Mode)	PCB Connector (Color)
Th1	Room Air Temperature	CN_ROOM (yellow)
Th2	Pipe In Temperature	CN_PIPE_IN (white)
Th3	Pipe Out Temperature	CN_PIPE_OUT (red)

# MULTI POSITION AIR HANDLING UNIT INDOOR UNITS

MULTI F  
MULTI F MAX

## Wiring Diagram

Figure 250: Multi Position Air-Handling Indoor Unit Wiring Diagram for KNMLB121A, KNMLB181A, KNMLB241A.





# MULTI POSITION AIR HANDLING UNIT INDOOR UNITS

MULTI F  
MULTI F MAX

## Wiring Diagram

Table 120: Wiring Diagram Connections.

Connection Name	Location	Function
CN-POWER	AC power supply	AC Power line
CN-MOTOR1	Fan motor output	Motor output of BLDC
CN_OUT	Heater	Connection for heater
CN-D/PUMP	Drain pump output	AC output for drain pump
CN-FLOAT	Float switch input	Float switch sensing
CN-ZONE	Zone controller	Zone controller connection
CN-OPTION	Optional PCB EPROM	Option PCB connection
CN-EXT	External ON / OFF controller	External ON / OFF controller connection
CN-DISPLAY	Display	Display of indoor status
CN-CC	Dry contact	Dry Contact connection
CN-PIPE/OUT (RD)	Discharge pipe sensor	Pipe out thermistor
CN-LEAK (VI)	Refrigerant leak detector	Refrigerant leak detector connection
CN-PIPE/IN (WH)	Suction pipe sensor	Pipe in thermistor
CN-REMO (GN)	Wired remote controller	Wired remote control connection
CN-ROOM (YL)	Room sensor	Room air thermistor
CN-DAMPER	Damper Controller	Damper connection
CN-AIRC	Air Cleaner	Air Cleaner connection
CN-WF	Wifi	Wifi Module connection
CN-PTC	Auxiliary Heater	Auxiliary Heater

Table 121: DIP Switch Settings.

DIP Switch Settings		OFF	ON	Description
SW1	Communication	Off (default)	—	—
SW2	CYCLE	Off (default)	—	—
SW3	GROUP	Master	Slave	Group control setting using wired remote controller.
SW4	DRY CONTACT	Variable	Auto	Dry contact mode setting. 1. Variable: Auto/manual mode can be chosen using the wide wired remote controller or wireless remote controller (factory setting is the manual mode). 2. Auto: For dry contact, it is always auto mode.
SW5	EXTRA1	Off	On	• ON: Fan operates continuously. • OFF: Default (Fan does not operate continuously).
SW6	HEATER	Off	On	• ON: Automatic heater operation. • OFF: Default (manual heater operation).
SW7				Off
SW8				On

To operate the indoor unit without Internal Electric Heater , DIP switch 1, 2, and 6 must be set OFF .

To operate the indoor unit with Internal Electric heater , DIP switch 6 must be set ON.

- SW6 ON: Automatic Heater operation: Heater operates automatically.
- SW6 OFF: Manual Heater operation: Owner involvement is required for on/off operation and will not permit auto emergency operation.

If you operate the indoor unit with Internal Electric heater with DIP switch 5, note the following:

- SW5 ON: Fan operates continuously. During defrosting or oil return operation, uninterrupted heating can be attained, as a result of continuous heater and fan operation.
- SW5 OFF: Fan discontinuous operation. There would be a reduction in heating capacity while defrosting or oil return operation.

Table 122: DIP Switch Settings.

Switch	Function	Description	Setting OFF	Setting ON	Default
SW1	Communication	N/A (Default)	-	-	Off
SW2	Cycle	N/A (Default)	-	-	Off
SW3	Group control	Selection of Main or Sub	Main	Sub	Off
SW4	Dry contact mode	Selection of dry contact mode	Wired/wireless remote controller selection of Manual or Auto operation mode	Auto	Off
SW5	Installation	Fan continuous operation	Continuous operation removal	-	Off
SW6	Heater linkage	N/A	-	-	Off
SW7	Ventilator linkage	Selection of ventilator linkage	Linkage removal	Working	Off
	Vane selection (console)	Selection of up/down side vane	Up side + down side vane	Up side vane only	
	Region selection	Selection tropical region	General model	Tropical model	
SW8	Refrigerant leak detector	Selection of installed or not installed	Not installed	Installed	On

To operate the indoor unit without an Internal Electric Heater accessory, DIP switches 1, 2, and 6 must be set OFF.

To operate the indoor unit with an Internal Electric Heater accessory, DIP switch 6 must be set ON.

- SW6 ON: Automatic Heater operation: Heater operates automatically.
- SW6 OFF: Manual Heater operation: Owner involvement is required for on/off operation and will not permit auto emergency operation.

For units with an Internal Electric heater, note the following for DIP switch 5:

- SW5 ON: Fan operates continuously. During defrosting or oil return operation, uninterrupted heating can be attained, as a result of continuous heater and fan operation. During defrosting or oil return operation, tepid air can come out.
- SW5 OFF: Fan discontinuous operation. There would be a reduction in heating capacity while defrosting or oil return operation.

# MULTI POSITION AIR HANDLING UNIT INDOOR UNITS

MULTI F  
MULTI F MAX

## Factory Supplied Parts and Materials

### Factory Supplied Materials

- Owner's Manual
- Installation Manual

### Required Tools

- Level
- Screwdriver
- Electric drill
- Hole core drill
- Flaring tool set
- Torque wrenches
- Hexagonal wrench
- Gas-leak detector
- Thermometer

### WARNING

Installation work must be performed by trained personnel and in accordance with national wiring standards and all local or other applicable codes. Improper installation can result in fire, electric shock, physical injury, or death.

### NOTICE





Read all instructions before installing this product. Become familiar with the unit's components and connections, and the order of installation. Incorrect installation can degrade or prevent proper operation.

### Selecting the Best Location

#### Do's


- Place the unit where air circulation through the ducts will not be blocked.
- Place the unit where drainage can be obtained easily.
- Place the unit where noise prevention is taken into consideration.
- Ensure there is sufficient strength to bear the load of the indoor unit.
- Ensure there is sufficient maintenance space.
- Locate the indoor unit in a location that is level, and where it can be easily connected to the outdoor unit / branch distribution unit.

#### Don'ts

-  Do not install the unit near a heat or steam source, or where considerable amounts of oil, iron powder, or flour are used.
-  Do not install the unit where sulfuric acid and flammable or corrosive gases are generated, vented into, or stored.
-  Do not install the unit near high-frequency generators.
-  Do not install the unit near a doorway.

**The unit will be damaged, will malfunction, and/or will not operate as designed if installed in any of the conditions listed.**

### NOTICE

-  Indoor units (IDUs) must not be placed in an environment where the IDUs will be exposed to harmful volatile organic compounds (VOCs) or in environments where there is improper air make up or supply or inadequate ventilation. If there are concerns about VOCs in the environment where the IDUs are installed, proper air make up or supply and/or adequate ventilation must be provided. Additionally, in buildings where IDUs will be exposed to VOCs, consider a third party factory-applied epoxy coating to the fan coils for each IDU where the entire coil is dipped, not sprayed.
- If the unit is installed near a body of water, the installation parts are at risk of corroding. Appropriate anti-corrosion methods must be taken for the unit and all installation parts.

### Installing in an Area Exposed to Unconditioned Air

In some installation applications, areas (floors, walls) in some rooms will be exposed to unconditioned air (room will be above or next to an unheated garage or storeroom). To countermeasure:

- Verify that carpet is or will be installed (carpet will increase the temperature by three degrees).
- Add insulation between the floor joists.
- Install radiant heat or another type of heating system to the floor.

### Installing in an Area with High Humidity Levels

If the environment is prone to humidity levels of 80% or more (near the ocean, lakes, etc.) or where steam could collect in the plenum:

- Install additional insulation to the indoor unit (glass wool insulation >13/32 inches thick).
- Install additional insulation to the refrigerant piping (insulation >13/16 inches thick).
- Seal all gaps between the indoor unit and the ceiling tiles (make the area air tight) so that humidity does not transfer from the plenum to the conditioned space. Also, add a ceiling grille for ventilation.

Figure 252: Clearance Requirements.

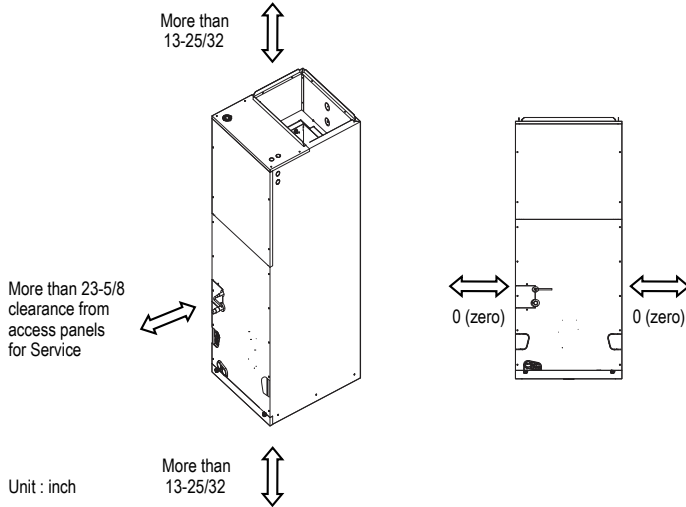


Figure 253: General and Duct Connection Dimensions.

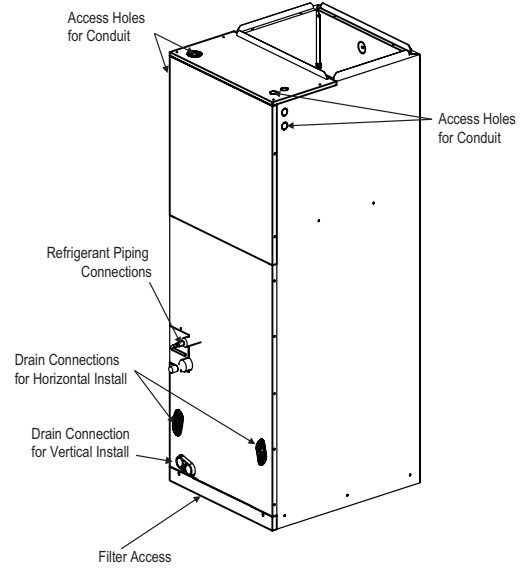
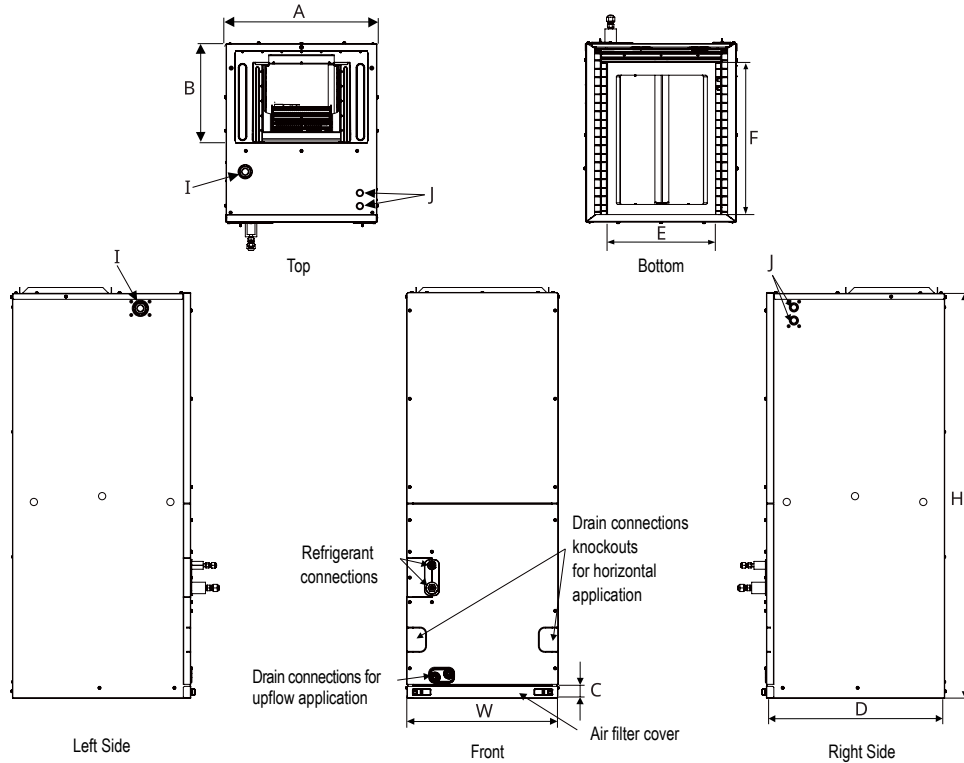


Figure 254: Location of Access Holes and Piping Connections.



(Unit: inch (mm))

Capacity (kBtu/h (RT))	Dimensions								Wiring Knock out		Refrigerant Connections Pipe size	
	H	W	D	A	B	C	E	F	I	J	Liquid	Gas
	Height	Width	Depth						Heater Power	Main power Communication		
12(1.0)	48 - 21/32	18	21 - 3/8	16	11 - 1/16	1 - 11/16	13 - 3/32	18 - 5/16	1 - 11/16	7/8	1/4	3/8
18(1.5)	(1 236)	(457)	(543)	(405.8)	(281.3)	(42.5)	(332.6)	(465)	(43)	(22)	(6.35)	1/2
24(2.0)											(12.7)	
30(2.5)	55 - 3/16	21	21 - 3/8	19	11 - 1/16	1 - 11/16	16 - 3/32	18 - 5/16	1 - 11/16	7/8	3/8	5/8
36(3.0)	(1 401)	(533)	(543)	(482)	(281.3)	(42.5)	(408.8)	(465)	(43)	(22)	(9.52)	(15.88)

# MULTI POSITION AIR HANDLING UNIT INDOOR UNITS

MULTI F  
MULTI F MAX

## Installation and Best Layout Practices

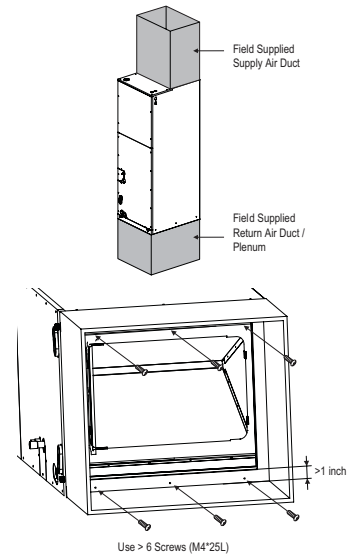
### NOTICE

Multi Position Air Handling Units can be installed in a choice of vertical upflow, vertical downflow (with optional downflow kit), or horizontal (left or right side) configurations.

### Vertical (Upflow) Installation

- Unit must be positioned properly for plenum / duct installation.
- To maintain proper air flow, minimum height clearance is 14 inches.
- Plenum must be strong and secure enough to support the installation of adapter collars to accommodate duct work.
- Air handler platform must be sturdy enough to support the frame, plus any accessories (e.g., filter box).
- To prevent air leaks, seal all duct work according to local codes, but make sure that filter access is still unobstructed.
- Vibration isolators (field supplied) must be installed between the unit frame and the platform. If necessary, provide the installing contractor with an illustration of where the vibration isolator must be added and how it must be positioned.

Figure 255: Vertical Installation / Attaching the Bottom Duct.



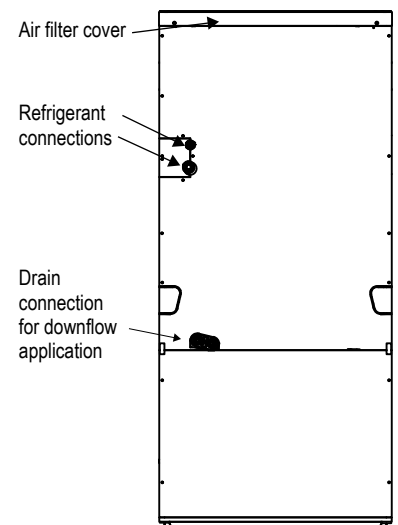
### NOTICE

⊘ Do not install the screws on the front and back of the unit; doing so will block filter installation.

### Vertical (Downflow) Installation

The Multi Position Air Handling Unit can be field-converted to vertical downflow operation. The optional vertical downflow kit PNDFA0 is required. The coil must be removed and repositioned in the chassis with the brackets of the downflow kit. For installation details, refer to the instructions included with the kit.

Figure 256: Chassis after Downflow Field Conversion.



### Horizontal Installation

- Units will be installed in horizontal left or horizontal right configuration. Horizontal left is the factory default configuration. For horizontal right, the unit must be field converted. The horizontal right conversion requires removing the internal drain pan from the left side of the unit and reinstalling on the right side. No conversion kit is required. Refer to the installation manual for details.
- Units must be installed so that the access panels face to the side, not facing up or down.
- Installation must be in accordance with all relevant building codes, which will necessitate the installation of an external condensate pan (position the unit in or above the external condensate pan).
- If the units are going to be suspended, use angled steel support brackets with threaded rods to provide support from the bottom. The brackets / threaded rods must be comparatively bigger / longer than the unit, and each must be centered on the part of the frame it supports.
- If the unit will not be suspended, use angled steel support brackets, but also add vibration isolators (field supplied) to avoid sound transmission. If necessary, provide the installing contractor with an illustration of where the vibration isolator must be added and how it must be positioned.
- Unit must be positioned properly for plenum / duct installation.
- Plenum must be strong and secure enough to support the installation of adapter collars to accommodate duct work.

Figure 257: Typical Horizontal Left Installation.

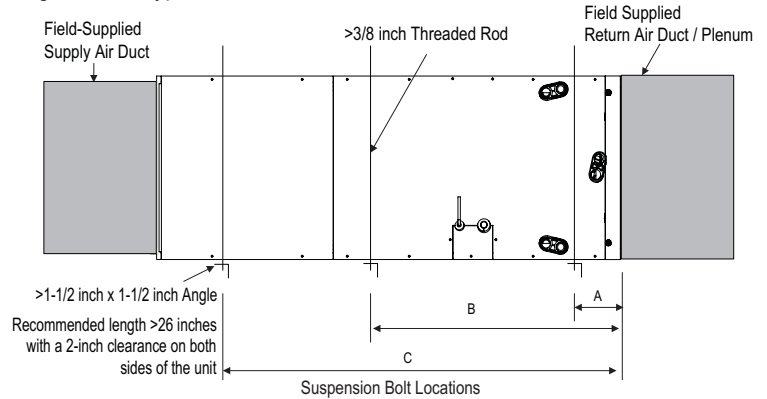


Figure 258: Typical Horizontal Right Installation.

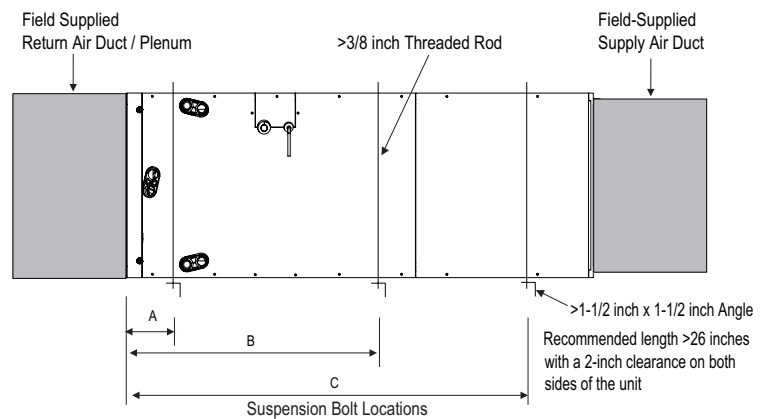


Table 123: Bracket / Bolt Position Dimensions for Horizontal Left and Horizontal Right Installation.

Model	Dimensions (inches)		
	A	B	C
KNMLB121A	4	23	41-1/2
KNMLB181A	4	23	41-1/2
KNMLB241A	4	23	41-1/2
KNMLB301A	4	29	48
KNMLB361A	4	29	48

### NOTICE

To ensure proper drainage for horizontal installations, unit must be installed within  $\pm 1/8$  inches level of the unit's length and width.

# MULTI POSITION AIR HANDLING UNIT INDOOR UNITS

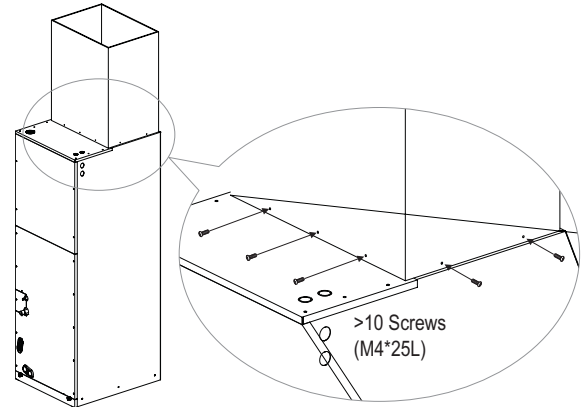
MULTI F  
MULTI F MAX

## Installation and Best Layout Practices

### Installing the Ducts

- Use more than ten (10) screws to securely attach the supply ducts to the unit. To prevent air leaks, seal around the duct opening before the duct is secure.
- To prevent vibration transmission, install flexible connectors between ducts and the unit. The flexible connectors must be made of a heat-resistant material at the discharge connection if an electric heater is installed.
- Duct work must be insulated and covered with vapor barrier when routed through unconditioned spaces. Include enough insulation to prevent condensate from forming on the ducts.
- It will be necessary to add internal acoustical insulation lining for a metal duct system if it does not include a 90° elbow and ten (10) feet between the main duct and the first branch.
- Fibrous glass ducts could be used as a substitute if built and installed in accordance with the most recent edition of the Sheet Metal and Air-Conditioning Contractors' National Associate (SMACNA) standard.
- Also, fibrous duct work and acoustical insulation lining must also follow National Fire Protection Standard 90A or B as tested by UL Standard 181 for Class 1 air ducts.

Figure 259: Securing the Ducts to the Unit.



### Installing the Drain System

#### General Specifications

- To prevent property damage, optimize drain system performance by installing both a primary and secondary drain line, and properly size the condensate traps.
- The primary and secondary drain line must be trapped to allow proper drainage of condensate water. If the secondary drain line is not used, it must be capped.
- Do not block the filter access panel when installing the condensate drain piping. Prime the primary and secondary condensate traps after running both to the drain pan.
- If the unit is installed above an inhabited space, add a field-supplied external condensate pan that runs underneath the entire frame (to prevent damage from overflow). The additional external condensate line must run from the unit to the external condensate pan.
- Drain all generated condensate from the external condensate pan to an appropriate area. Install a trap in the condensate lines as near to the indoor unit coil as possible.
- For horizontal right operation, the drain pan must be removed from the interior left side of the unit and reinstalled on the right side.
- All condensate must be drained from the external condensate pan to some noticeable area.
- To prevent overflow, the outlet of each trap must be positioned below its connection to the condensate pan.
- All traps must be primed, insulated, and leak tested if located above an inhabited space.
- Use a 3/4-inch PVC male pipe thread fitting at the condensate pan connection. Tighten gently.
- Point the drain hose down for easier flow.
- Do not just use the pipe joint or PVC / CPVC piping on the indoor unit drain line connections. Use only Teflon tape.
- Design the drain system to plan for winter operation (condensate line will freeze up if condensate does not properly drain away).

Figure 260: Typical Vertical Up/Down Installation Drain System.

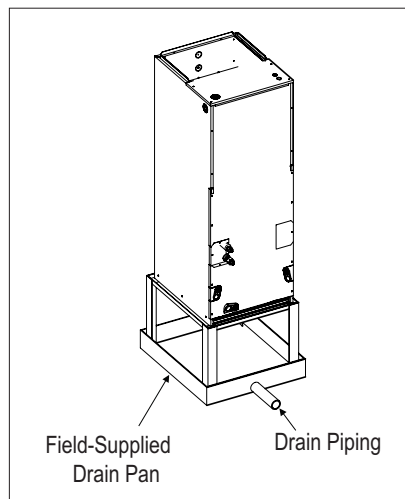
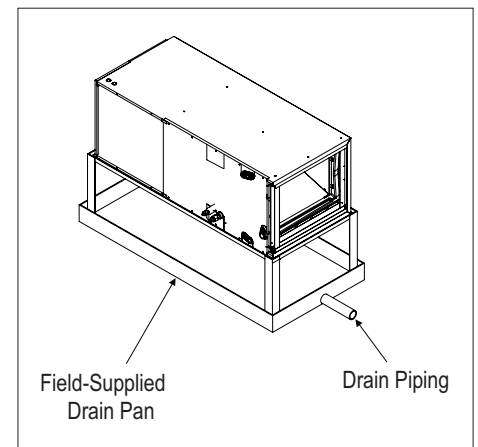


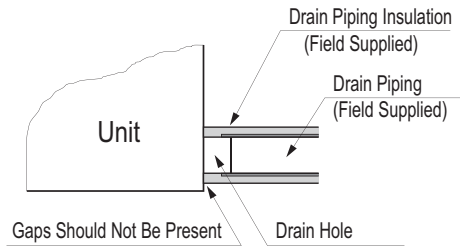
Figure 261: Typical Horizontal Left/Right Installation Drain System.



### Drain Piping Specifications

- Drain piping must have downward gradient of at least 1/50 to 1/100; to prevent reverse flow, slope must not be straight up and down.
- Do not damage the drain port on the indoor unit when connecting the field-supplied drain piping.

Figure 262: Close up of Drain Piping Connection.



### Insulating the Refrigerant and Drain Piping

#### ⚠ WARNING

Ensure all piping is insulated. Exposed piping can cause burns if touched.

#### Refrigerant Piping Insulation

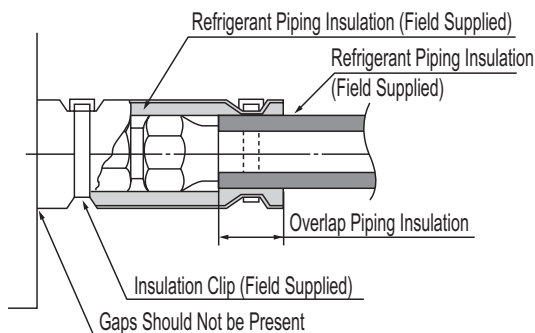
Field-installed vapor and liquid refrigerant piping lines must be properly and completely covered in insulation (up to the indoor unit piping connections) and must comply with federal, state, and local requirements. Any exposed piping will generate condensate or will cause burns if touched. Insulation for this field-installed refrigerant piping must have a minimum heat resistance of 248°F.

If the indoor unit is installed and is operated at an extended period in a highly humid environment (dew point temperature >73°F), however, condensate will form. To prevent this phenomenon, install adiabatic glass wool insulation with a thickness of 7/16 to 13/16 inches thick. Also, install glass wool insulation on all indoor units that are located in the ceiling plenum.

#### Drain Piping Insulation

Drain piping insulation must be 7/32 inches thick, minimum.

Figure 266: Close Up of Refrigerant Piping Connection Insulation.



### Field-Installed U-Trap Specifications

#### NOTICE

To prevent leaks cause by a block in the intake air filter, install a U-Trap.

A ≥ 2-9/16 inches

B ≥ 2C

C ≥ 2 x SP

SP = External Pressure in. WG

#### Example:

External Pressure= 0.4 in WG

A ≥ 2-9/16 inches

B ≥ 1-7/12 inches

C ≥ 19/24 inches

Figure 263: Installing the U-Trap.

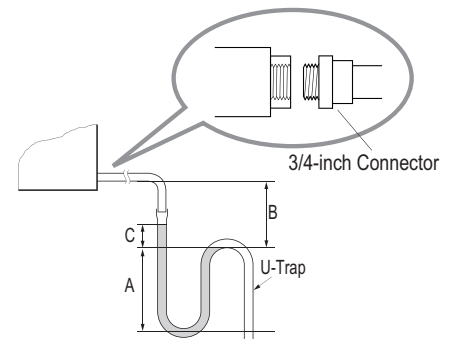


Figure 264: Vertical Primary and Secondary Drain Layout.

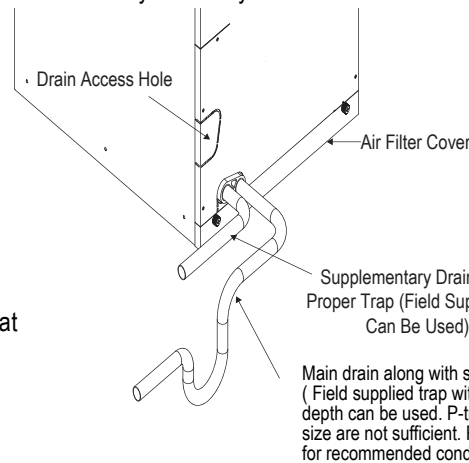


Figure 265: Horizontal Primary and Secondary Drain Layout.

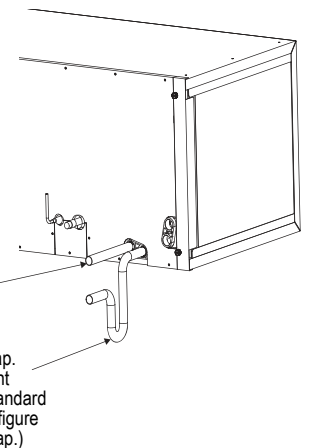
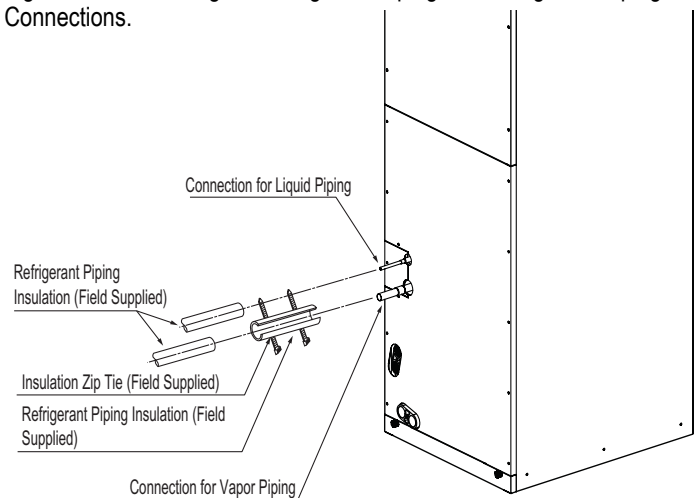


Figure 267: Insulating the Refrigerant Piping and Refrigerant Piping Connections.



# MULTI POSITION AIR HANDLING UNIT INDOOR UNITS

MULTI F  
MULTI F MAX

## Installation and Best Layout Practices

### Power Wiring / Communications Cable Guidelines

- Follow manufacturer's circuit diagrams in the technical manuals.
- Confirm power source specifications.
- Confirm that the electrical capacity is sufficient.
- Starting current must be maintained  $\pm 10$  percent of the rated current marked on the outdoor unit name plate.
- Confirm cable thickness specifications.
- It is required that a circuit breaker is installed, especially if conditions could become wet or moist.
- Include a disconnect in the power wiring system, add an air gap contact separation of at least 1/8 inch in each active (phase) conductor.

### ⚠ WARNING

- Loose wiring will cause unit to malfunction, overheat, and catch fire, resulting in severe injury or death.

### NOTICE

- Terminal screws will become loose during transport. Properly tighten the terminal connections during installation.
- A voltage drop will cause the following problems:
- Magnetic switch vibration, fuse breaks, or disturbance to the normal function of an overload protection device.
  - Compressor will not receive the proper starting current.

### Connecting the Power Wiring and Communications Cable

1. To access the terminal block, first unscrew the top front panel, and then unscrew the cover from the control box.
2. Knockout the access holes for the wiring. Insert the power wiring/communications cable from the outdoor unit or branch distribution unit (Multi F MAX systems only) through the conduits, pass the conduits through the designated access holes, and then insert the conduits into the control box. To prevent electromagnetic interference and product malfunction, leave a space between the power wiring and communications cable outside of the indoor unit.
3. Connect the power wiring and communications cables to the appropriate terminals on the indoor unit control board. Verify that the color and terminal numbers from the outdoor unit or branch distribution unit (Multi F MAX systems only) wiring match the color and terminal numbers on the indoor unit.
4. Fill in any gaps around the conduit access holes with sealant to prevent foreign particles from entering the indoor unit.

Figure 268: Connecting the Power Wiring and Communications Cable.

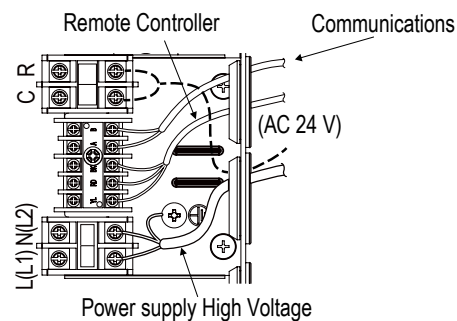
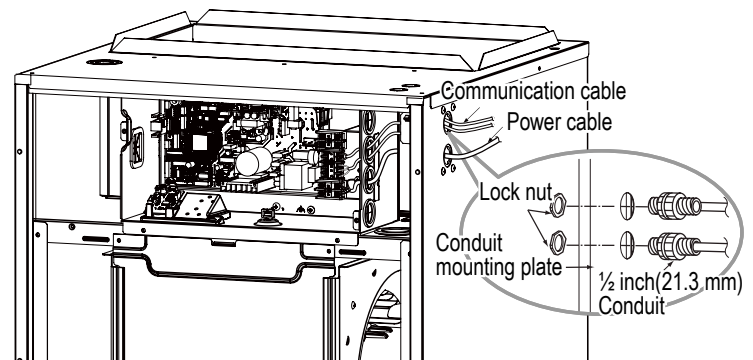
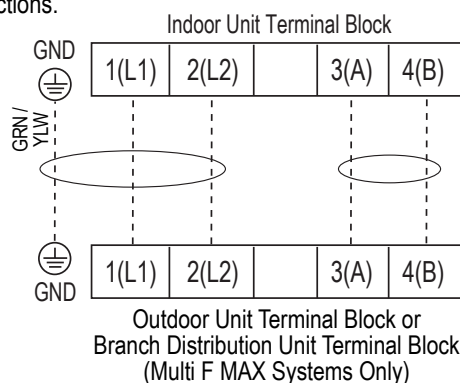


Figure 269: Indoor Unit to Outdoor Unit / Branch Distribution Unit (Multi F MAX systems only) Power Wiring / Communications Cable Connections.



### Controller Options

Multi Position Air Handling indoor units can be used with many LG-supplied wired controllers (sold separately). The wireless handheld controller (Model No. PWLSSB21H) is also an optional accessory with use of the wired controller.

#### Wired Controller Connections

Controllers can connect to the indoor unit in one of two different ways.

1. LG Wired Remote Extension Cable with Molex plug (PZCWRC1; sold separately) that connects to the CN-REMO terminal on the indoor unit PCB.
2. Field-supplied controller cable that connects to the indoor unit terminal block (must be at least UL2547 or UL1007, 22 AWG, two-core, one-shield core, at least FT-6 rated if local electric and building codes require plenum cable usage).

Figure 270: PZCWRC1 LG Wired Remote Extension Cable.

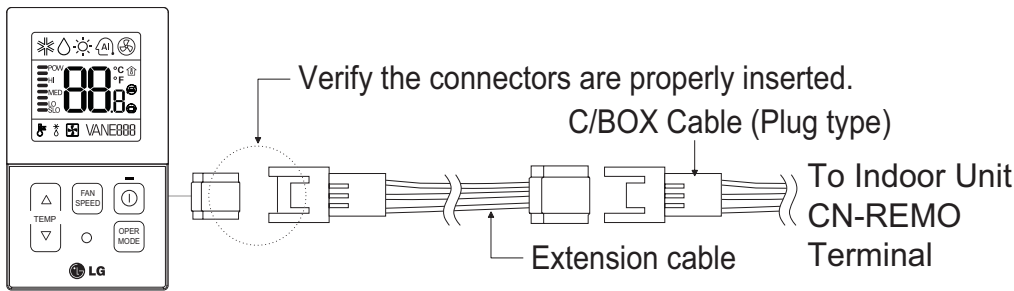
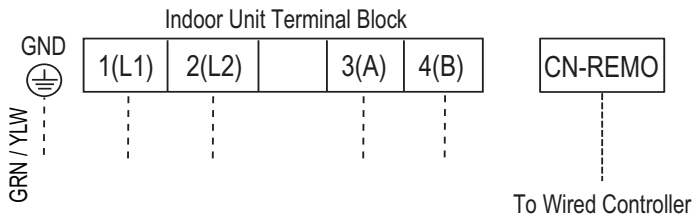


Figure 271: Wired Controller Connection on the Indoor Unit Terminal Block.



#### NOTICE

When using field-supplied controller cable, make sure to connect the yellow to yellow (communications wire), red to red (12V power wire), and black to black (ground wire) terminals from the remote controller to the indoor unit terminal blocks.

# MULTI POSITION AIR HANDLING UNIT INDOOR UNITS

MULTI F  
MULTI F MAX

## Installation and Best Layout Practices

### Wired Controller Placement

Wired controllers include a sensor to detect room temperature. To maintain comfort levels in the conditioned space, the wired controller must be installed in a location away from direct sunlight, high humidity, and where it could be directly exposed to cold air. Controller must be installed four (4) to five (5) feet above the floor where its LED display can be read easily, in an area with good air circulation, and where it can detect an average room temperature.

- ⊘ Do not install the wired controller near or in:
- Drafts or dead spots behind doors and in corners
  - Hot or cold air from ducts
  - Radiant heat from the sun or appliances
  - Concealed pipes and chimneys
  - An area where temperatures are uncontrolled, such as an outside wall

### Hanging the Wired Controller

1. These steps are typical. Refer to the installation instructions with your controller. The controller wiring / cable can be installed in one of three directions: top, back, or on the right side. If top or right side installation is desired, remove cable guide grooves on the controller, and then position wiring / cable on applicable side.
2. Choose and mark the area of installation, and then screw the wall plate into place (using the provided parts). Install the controller wall plate to fit the electrical box if one is present. Ensure that no gaps exist between the wall plate and the wall itself.
3. Arrange wiring / cables so as not to interfere with the controller circuitry. Position the wired controller on the wall plate. Snap into place by pressing the bottom part of the wired controller onto the wall plate. Make sure that no gaps exist between the wired controller and the wall plate on all sides.
4. To remove wired controller from the wall plate, insert a screwdriver into the two holes at the bottom. Twist screwdriver to release controller. ⊘ Do not damage the controller components when removing.

Figure 272: Proper Location for the Wired Controller.

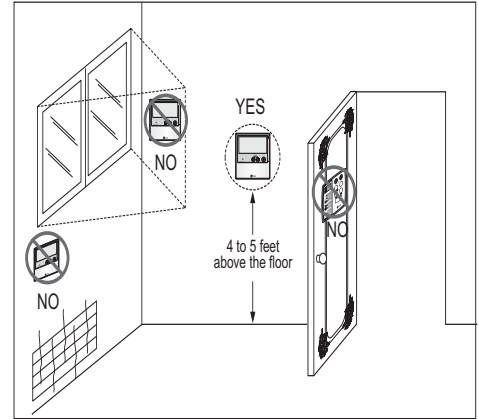


Figure 273: Removing the Cable Guide Grooves.

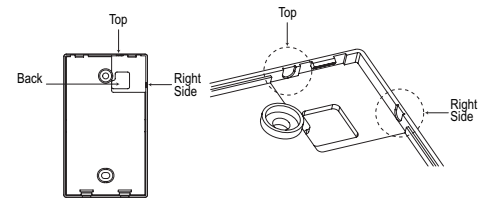


Figure 274: Attaching the Wall Plate.

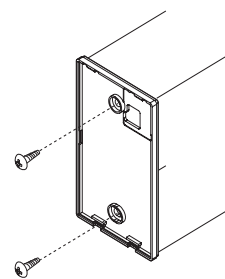
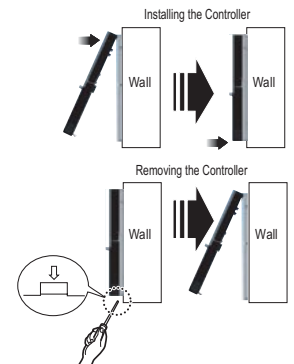


Figure 275: Installing / Removing the Controller.



### Assigning the Thermistor for Temperature Detection

Each indoor unit includes a return air thermistor assigned to sense the temperature. If a wired controller is installed, there is a choice of sensing temperature with either the indoor unit return air thermistor or the thermistor in the wired controller. It is also an option to set both thermistors to sense temperature so that indoor unit bases its operation on the first thermistor to reach the designated temperature differential. For applicable indoor units, an optional Remote Temperature Sensor can be used in lieu of the return air thermistor—either alone or in conjunction with a wired controller thermistor as previously described.

# APPLICATION GUIDELINES

**Equipment Selection Procedure on page 218**

**Placement Considerations on page 226**

To choose the multi-zone system that is the most appropriate for the space, as with traditional air-conditioning systems, follow similar protocols outlined in Manual J from the Air Conditioning Contractors of America (ACCA; see [www.acca.org](http://www.acca.org)).

1. Obtain the design conditions, and calculate the maximum cool and heat loads for the structure.
2. Select the equipment (choosing the appropriate indoor units and outdoor unit):
  - Determine number of zones.
  - Determine total number of indoor units (refer to zone load calculations when choosing indoor units).
  - Determine number of indoor units allocated to each outdoor unit, considering allowable indoor unit connections, both indoor unit and outdoor unit capacities, and system piping capabilities.
3. Determine the corrected capacity for the indoor units and outdoor unit using LATS HVAC software (preferred method) or:
  - System Combination Tables.
  - Capacity Tables (it will be necessary to interpolate).
  - Capacity Coefficient Factors (such as refrigerant line length derates, design condition derates, defrost operation derate [heating mode], altitude derate [if applicable]).
4. Compare corrected capacities to load calculations.
5. Reselect equipment if necessary.

## Obtain Design Conditions, Calculate Maximum Cool / Heat Loads

Obtain the winter outdoor / indoor temperature and summer and winter outdoor / indoor temperature design parameters for the location in which the system is installed. Determine if summer or winter design gains, relative humidity, and building features like skylights, orientation, number of occupants, etc., would change the total heat loss / gain and sensible / latent heat gain, and then calculate the maximum cool and heat loads for the space (using Manual J or energy modeling programs).

## Select the Equipment

### Determine the Number of Zones

Multi F and Multi F with LG RED heat pump systems can cool or heat, but not simultaneously. When designing larger-capacity Multi F heat pump systems or a Multi F MAX system, the designer will be able to combine spaces with similar load profiles located near or adjacent to each other into "thermal zones." After combining like spaces into zones that will be served by a single (or grouped) indoor unit(s), calculate the peak cooling and heating loads for each zone.

### Choosing the Appropriate Indoor Units

Determine the appropriate indoor unit capacity that satisfies the given zone load calculations, and choose how many (and which styles of) indoor units will be required. See the table on the next page for allowable indoor unit to outdoor unit connections, and the maximum number of connectable indoor units on each Multi F and Multi F MAX outdoor unit. When choosing indoor units, also consider the cooling and heating CFM, featured airflow specifications, and static pressure (if applicable) for each indoor unit.

⊗ Avoid oversizing indoor units in an attempt to increase the air exchange rate in the space. Multi F and Multi F MAX systems are designed for minimum airflow over the coil to maximize latent capacity while cooling, maintain a comfortable, consistent discharge air temperature while heating, and minimize fan motor power consumption. In extreme cases, oversizing the indoor units will affect outdoor unit size selection and compromise the outdoor unit's ability to effectively match the space load(s).

For proper system operation:

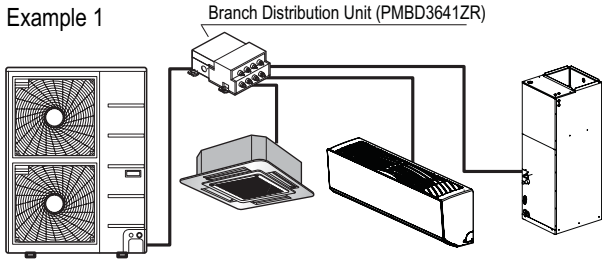
1. At least two indoor units must be connected to the outdoor unit.
2. Total connected indoor unit nominal capacity must be a minimum 40% and a maximum of 133% of outdoor unit nominal capacity.
3. To calculate the connected total indoor unit nominal capacity, simply sum up the nominal capacities of all indoor units.
  - For mid static duct and multi position air handling indoor units, a 1.3 multiplier must first be applied before adding to the sum of other indoor units (when connected to an ODU **other** than the KUMXB601A, KUMXA361A, KUMXA421A or KUMXA481A).
  - When mid static duct and / or multi position air handling indoor units are the **only** connected indoor units, the multiplier is 1.2.

## NOTICE

For allocated capacity information, see the combination tables in the "Multi F / Multi F MAX Combination Data Manual" on [www.lghvac.com](http://www.lghvac.com). For performance data, see "Multi F / Multi F MAX Performance Data Manual" on [www.lghvac.com](http://www.lghvac.com). Also refer to the appropriate manuals on [www.lghvac.com](http://www.lghvac.com) for combination and capacity data for Multi F with LG RED / Multi F MAX with LG RED units.

## Multiplier Examples

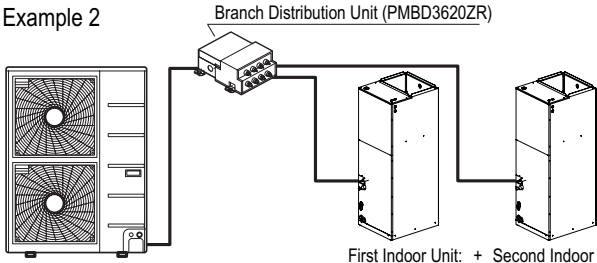
**Example 1**



Outdoor Unit: KUMXB541A  
 First Indoor Unit: KNUDB121A  
 Second Indoor Unit: KNUAB091A  
 Third Indoor Unit: KNMLB361A

Total Capacity Index = 12 + 9 + 36 x 1.3 = 67.8 < 73  
 Acceptable Combination

**Example 2**



Outdoor Unit: KUMXB541A  
 First Indoor Unit: KNMLB241A  
 Second Indoor Unit: KNMLB241A

Total Capacity Index = 24 x 1.2 + 24 x 1.2 = 57.6 < 73  
 Acceptable Combination

Table 124: Allowable Indoor Unit to Multi F / Multi F MAX Outdoor Unit Connections.

Indoor units		Outdoor units						
Model Type	Indoor Unit Nominal Capacity (Btu/h)	KUMXB181A	KUMXB241A	KUMXB301A	KUMXB361A	KUMXB481A	KUMXB541A	KUMXB601A
		Maximum No. of Connectable Indoor Units						
		2	3	4	4	8	8	8
ART COOL Mirror	9,000	0	0	0	0	0	0	0
	12,000	0	0	0	0	0	0	0
	18,000	-	0	0	0	0	0	0
High Efficiency Wall Mounted	7,000	0	0	0	0	0	0	0
	9,000	0	0	0	0	0	0	0
	12,000	0	0	0	0	0	0	0
	15,000	0	0	0	0	0	0	0
	18,000	-	0	0	0	0	0	0
Low Wall Console	9,000	0	0	0	0	0	0	0
	12,000	0	0	0	0	0	0	0
	15,000	0	0	0	0	0	0	0
Low Static Duct	9,000	0	0	0	0	0	0	0
	12,000	0	0	0	0	0	0	0
	18,000	-	0	0	0	0	0	0
Convertible Mid Static Duct	9,000	0	0	0	0	0	0	0
	12,000	0	0	0	0	0	0	0
	18,000	-	0	0	0	0	0	0
	24,000	-	-	0	0	0	0	0
Mid Static Duct	30,000	-	-	-	0	0	0	0
	36,000	-	-	-	-	0	0	0
Four-Way Ceiling Cassette	7,000	0	0	0	0	0	0	0
	9,000	0	0	0	0	0	0	0
	12,000	0	0	0	0	0	0	0
	18,000	-	0	0	0	0	0	0
Multi Position Air Handling Unit	12,000	0	0	0	0	0	0	0
	18,000	-	0	0	0	0	0	0
	24,000	-	-	0	0	0	0	0
	30,000	-	-	-	0	0	0	0
	36,000	-	-	-	-	0	0	0

# EQUIPMENT SELECTION PROCEDURE

MULTI F  
MULTI F MAX

Multi F and Multi F MAX Indoor Unit Engineering Manual

Table 125: Allowable Indoor Unit to Multi F / Multi F MAX with LGRED Outdoor Unit Connections.

Indoor units		Outdoor units					
Model Type	Indoor Unit Nominal Capacity (Btu/h)	KUMXA181A	KUMXA241A	KUMXA301A	KUMXA361A	KUMXA421A	KUMXA481A
		Maximum No. of Connectable Indoor Units					
		2	3	4	5	6	8
ART COOL Mirror	9,000	0	0	0	0	0	0
	12,000	0	0	0	0	0	0
	18,000	-	0	0	0	0	0
High Efficiency Wall Mounted	7,000	0	0	0	0	0	0
	9,000	0	0	0	0	0	0
	12,000	0	0	0	0	0	0
	15,000	0	0	0	0	0	0
	18,000	-	0	0	0	0	0
	24,000	-	0	0	0	0	0
Low Wall Console	9,000	0	0	0	0	0	0
	12,000	0	0	0	0	0	0
	15,000	0	0	0	0	0	0
Low Static Duct	9,000	0	0	0	0	0	0
	12,000	0	0	0	0	0	0
	18,000	-	0	0	0	0	0
Convertible Mid Static Duct	9,000	0	0	0	0	0	0
	12,000	0	0	0	0	0	0
	18,000	-	0	0	0	0	0
	24,000	-	-	0	0	0	0
Mid Static Duct	30,000	-	-	-	0	0	0
	36,000	-	-	-	0	0	0
Four-Way Ceiling Cassette	7,000	0	0	0	0	0	0
	9,000	0	0	0	0	0	0
	12,000	0	0	0	0	0	0
	18,000	-	0	0	0	0	0
Multi Position Air Handling Unit	12,000	0	0	0	0	0	0
	18,000	-	0	0	0	0	0
	24,000	-	-	0	0	0	0
	30,000	-	-	-	0	0	0
	36,000	-	-	-	0	0	0

## Choosing the Appropriate Outdoor Unit

After all indoor units are properly sized to offset the applicable loads in each zone, select the outdoor unit by choosing a size that meets both the load-cooling requirement, and offsets the sum of the heating load. Then, the system's combination ratio must be evaluated and confirmed it is within the allowable range (the combination ratio compares the nominal capacity of all connected indoor units to the nominal capacity of the outdoor unit serving them). The total nominal capacity of all indoor units must be smaller than the total nominal capacity of the outdoor unit. If the combination ratio is more than 100%, the designer is undersizing the outdoor unit relative to the combined nominal capacity of the connected indoor units. In some designs, oversized indoor units will be unavoidable in the case where the smallest size indoor unit available from LG is larger than what is necessary to satisfy the zone load. This scenario will also occur when an indoor unit selection one size down from the selected unit is slightly short of fulfilling the design load requirements, and the designer must choose the next largest size unit. Sometimes it is required to choose a larger capacity outdoor unit if the installation space is big enough. Also, it will be prudent to oversize the outdoor unit to address those times when the weather conditions will exceed the design conditions, to minimize the possibility of ventilation systems that causes the space temperature to drift outside design parameters, or when the indoor unit's entering air temperature falls outside the approved design temperature range.

Table 126: Multi F / Multi F Max Rated Outdoor Unit Capacity.

		Outdoor Units						
		KUMXB181A	KUMXB241A	KUMXB301A	KUMXB361A	KUMXB481A	KUMXB541A	KUMXB601A
Rated Capacity (Btu/h)*	Cooling	18,000	24,000	30,000	32,800	48,000	50,500	56,000
	Heating	22,000	24,600	32,000	36,000	54,000	58,000	64,000
Connectable Indoor Units	Minimum No. of Connectable IDUs	2	2	2	2	2	2	2
	Maximum No. of Connectable IDUs	2	3	4	4	8	8	8
	Maximum Capacity Index	24,000	33,000	40,000	48,000	65,000	73,000	81,000

Table 127: Multi F / Multi F MAX with LGRED Rated Outdoor Unit Capacity.

		Outdoor Units					
		KUMXA181A	KUMXA241A	KUMXA301A	KUMXA361A	KUMXA421A	KUMXA481A
Rated Capacity (Btu/h)*	Cooling	18,000	24,000	28,400	36,000	42,000	48,000
	Heating	22,000	26,000	30,000	45,000	48,000	52,500
Connectable Indoor Units	Minimum No. of Connectable IDUs	2	2	2	2	2	2
	Maximum No. of Connectable IDUs	2	3	4	5	6	8
	Minimum Capacity Index	14,000	14,000	14,000	18,000	18,000	18,000
	Maximum Capacity Index	24,000	33,000	40,000	48,000	56,000	65,000

## Determine the Corrected Capacity

The *corrected* cooling / heating capacity is different from the rated cooling / heating capacity. The corrected capacity includes changes in unit performance after considering design temperatures, available capacity that can be allocated from the outdoor unit, pressure drop due to refrigerant line length, defrost operation in heating mode, and (if applicable) altitude. Depending on the location of the building, additional capacity correction factors will need to be applied.

### Using the Outdoor Unit Cooling and Heating Capacity Tables

Rated cooling capacity ratings are obtained with air entering the indoor unit at 80°F dry bulb (DB) and 67°F wet bulb (WB), and outdoor ambient conditions of 95°F dry bulb (DB) and 75°F wet bulb (WB). Rated heating capacity ratings are obtained with air entering the indoor unit at 70°F dry bulb (DB) and 60°F wet bulb (WB) and outdoor ambient conditions of 47°F dry bulb (DB) and 43°F wet bulb (WB).

To evaluate the total outdoor unit capacity at design conditions perform a selection using LATS HVAC software (preferred method) or reference the Performance Data Capacity Tables. All design temperatures are not explicitly shown in the charts, therefore, interpolation will be necessary to calculate the capacity for specific design conditions. Based on the premise that capacity follows a linear curve, the following formula can be applied:

$$(y - y1) / (y2 - y1) = (x - x1) / (x2 - x1)$$

Where

- y = Missing Capacity (Capacity at the Design Temperature).<sup>1</sup>
- y1 = Capacity at Lower Temperature (Smaller value of the two nearest published TC data points).
- y2 = Capacity at Higher Temperature (Higher value of the two nearest published TC data points).
- x = Design Temperature (Temperature not shown in published capacity tables).<sup>2</sup>
- x1 = (Smaller value of the two nearest published temperature data points).
- x2 = (Larger value of the two nearest published temperature data points).

<sup>1</sup>Median between two published Total Capacity [TC] Btu/h data points in the capacity table.

<sup>2</sup>Median between two nearest published temperature data points.

### Using the Indoor Unit Cooling and Heating Capacity Tables

The data points shown in the indoor unit cooling and heating capacity charts are based on (and convey) an indoor unit operating with maximum possible refrigerant flow from the outdoor unit and before any derates are applied. In other words, the capacities displayed reflect what the indoor unit would produce if it was the only indoor unit that required capacity, and the outdoor unit did not have to allocate any capacity to another indoor unit.

System operation with a combination of indoor units is not conveyed in these charts, however, the information can be used to calculate indoor unit allocated capacity (without using the system combination tables). Simply calculate by using the formula:

$$Q_{idu}(combi) = Q_{odu}(rated) \times \frac{Q_{idu}(rated)}{\sum Q_{idu}(rated)}$$

Where

- Q<sub>idu</sub>(combi) = Individual Indoor Unit Combination Capacity.
- Q<sub>odu</sub>(rated) = Outdoor Unit Rated Capacity.
- Q<sub>idu</sub>(rated) = Individual Indoor Unit Rated Capacity.
- ΣQ<sub>idu</sub>(rated) = Total Connected Indoor Unit Rated Capacity.

## NOTICE

- The formula can be used to find individual indoor unit capacity for Multi F MAX / Multi F MAX with LGRED systems.
- A more accurate method to determine expected capacity would be to apply the outdoor unit's corrected capacity instead of rated capacity.



## Using the System Combination Tables

**Multi F system combination tables** illustrate how each indoor unit receives a percentage of total outdoor unit rated capacity. Allocation is based on:

- Combinations of Non-Ducted Indoor Units
- Combinations of Ducted Indoor Units
- Combinations of Mixed Non-Ducted and Ducted Indoor Units

**Multi F MAX system combination tables** only show the total connected indoor unit capacity, but individual indoor unit capacity can be calculated using the formula:

$$Q_{idu}(combi) = Q_{odu}(rated) \times \frac{Q_{idu}(rated)}{\sum Q_{idu}(rated)}$$

### NOTICE

A more accurate method to determine expected capacity would be to apply the outdoor unit's corrected capacity instead of rated capacity.

## Capacity Coefficient Factors

### Refrigerant Line Length Derates

For air-cooled systems, a capacity correction factor will have to be applied to account for the length of the system's refrigerant pipe. Rate of change in capacity due to increased piping lengths is shown in the tables below and on the next pages.

Table 128: Multi F / Multi F with LGRED Outdoor Unit (Multiple Piping) to Indoor Unit Refrigerant Line Length Derates.

Piping Length (feet)	Cooling Capacity (%)	Heating Capacity (%)
<b>7,000 Btu/h Indoor Unit Models</b>		
16.4	100.0	100.0
24.6	100.0	100.0
32.8	98.4	99.2
49.2	95.8	97.8
65.6	93.2	96.4
82.0	90.6	95.0
<b>9,000 Btu/h Indoor Unit Models</b>		
16.4	100.0	100.0
24.6	100.0	100.0
32.8	98.0	99.0
49.2	94.8	97.4
65.6	91.6	95.8
82.0	88.4	94.2
<b>12,000 Btu/h Indoor Unit Models</b>		
16.4	100.0	100.0
24.6	100.0	100.0
32.8	97.6	98.6
49.2	93.8	96.4
65.6	89.9	94.1
82.0	86.1	91.9
<b>15,000 Btu/h Indoor Unit Models</b>		
16.4	100.0	100.0
24.6	100.0	100.0
32.8	97.2	98.2
49.2	93.0	95.4
65.6	88.8	92.6
82.0	84.6	89.8
<b>18,000 Btu/h Indoor Unit Models</b>		
16.4	100.0	100.0
24.6	100.0	100.0
32.8	98.2	99.2
49.2	95.4	98.0
65.6	92.4	96.6
82.0	89.6	95.4

## Capacity Coefficient Factors - continued

Table 129: Multi F / Multi F with LGRED Outdoor Unit (Multiple Piping) to Indoor Unit Refrigerant Line Length Derates - continued.

Piping Length (feet)	Cooling Capacity (%)	Heating Capacity (%)
<i>24,000 Btu/h Indoor Unit Models</i>		
16.4	100.0	100.0
24.6	100.0	100.0
32.8	98.2	99.2
49.2	95.4	98.0
65.6	92.4	96.6
82.0	89.6	95.4
<i>30,000 Btu/h Indoor Unit Models</i>		
16.4	100.0	100.0
24.6	100.0	100.0
32.8	98.2	99.2
49.2	95.4	98.0
65.6	92.4	96.6
82.0	89.6	95.4
<i>36,000 Btu/h Indoor Unit Models</i>		
16.4	100	100
24.6	100	100
32.8	98.2	99.2
49.2	95.4	98.0
65.6	92.4	96.6
82.0	89.6	95.4

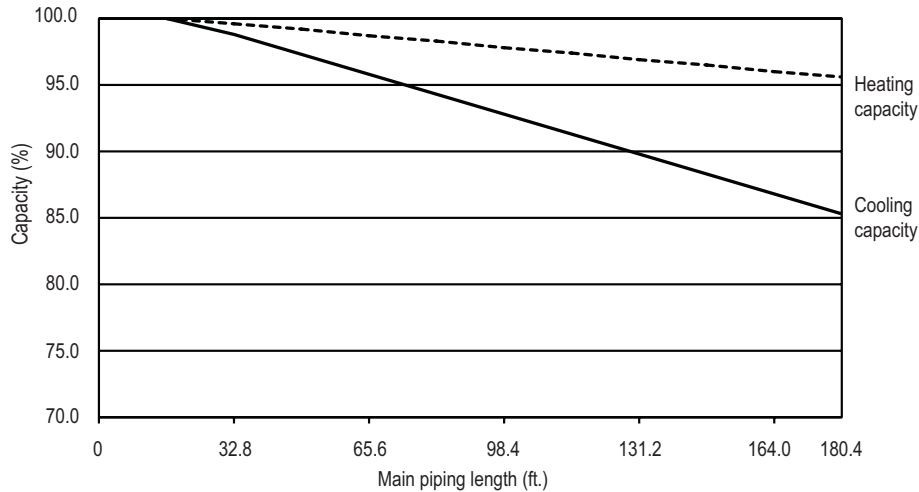
# EQUIPMENT SELECTION PROCEDURE

**MULTI F**  
**MULTI F MAX**

Table 130: Multi F MAX / Multi F MAX with LGRED Outdoor Unit to Branch Distribution Unit Refrigerant Line Length Derates.

Main Piping Length (feet)	16.4	32.8	49.2	65.6	82.0	98.4	114.8	131.2	147.6	164.0	180.4
Cooling Capacity (%)	100.0	98.8	97.3	95.8	94.3	92.8	91.3	89.8	88.3	86.8	85.3
Heating Capacity (%)	100.0	99.6	99.2	98.7	98.3	97.8	97.4	96.9	96.5	96.0	95.6

Figure 276: Multi F MAX / Multi F MAX with LGRED Outdoor Unit to Branch Distribution Unit Refrigerant Line Length Derate Chart.



Multi F and Multi F MAX Indoor Unit Engineering Manual

Table 131: Multi F MAX and Multi F MAX with LGRED Branch Distribution Unit to Indoor Unit Refrigerant Line Length Derates.

Piping Length (feet)	Cooling Capacity (%)	Heating Capacity (%)
<b>7,000 Btu/h Indoor Unit Models</b>		
16.4	100.0	100.0
32.8	98.0	99.5
49.2	96.0	98.9
<b>9,000 Btu/h Indoor Unit Models</b>		
16.4	100.0	100.0
32.8	97.5	98.8
49.2	95.0	97.5
<b>12,000 Btu/h Indoor Unit Models</b>		
16.4	100.0	100.0
32.8	97.0	98.3
49.2	94.0	96.5
<b>15,000 Btu/h Indoor Unit Models</b>		
16.4	100.0	100.0
32.8	97.2	98.2
49.2	93.0	95.4
<b>18,000 Btu/h Indoor Unit Models</b>		
16.4	100.0	100.0
32.8	98.3	99.5
49.2	96.5	99.0
<b>24,000 Btu/h Indoor Unit Models</b>		
16.4	100.0	100.0
32.8	97.8	99.2
49.2	95.5	98.4
<b>36,000 Btu/h Indoor Unit Models</b>		
16.4	100.0	100.0
32.8	97.9	98.8
49.2	95.7	97.6

## Altitude Correction Factor

The impact of air density must be considered on systems installed at a significant altitude above sea level, therefore, locally accepted altitude correction factors must be applied.

## Defrost Correction Factor for Heating Operation

The outdoor unit heating capacity will need to be adjusted for frost accumulation on air-cooled systems. If design day conditions are below the dewpoint of the surrounding air, frost will not be a problem and no correction factor is needed. In certain weather conditions, however, frost will form and accumulate on the air-cooled outdoor unit coil and impact the coils ability to transfer heat. If significant frost accumulates on the outdoor unit coil, a defrost algorithm will start automatically. The timing between defrost periods is determined by the system's ability to achieve a target head pressure value.

Capacity and AHRI ratings tables do not factor in capacity reduction when frost has accumulated on the condenser coil, nor during defrost operation.

Integrated heating capacity values can be obtained using the formula:

$$A = B \times C$$

Where:

A = Integrated Heating Capacity.

B = Value found in the Capacity Table.

C = Correction Factor for Frost Accumulation Factor (from Table 101).

Table 132: Outdoor Unit Frost Accumulation Factor (Heating)<sup>1</sup>.

Entering DB (°F)	19.4	23.0	26.6	32.0	37.4	41.0	44.6
Derate factor	0.98	0.95	0.93	0.86	0.93	0.96	1.0

<sup>1</sup>At 85% outdoor air relative humidity.

The frost accumulation factor does not account for effects of snow accumulation restricting airflow through the outdoor unit coil.

## NOTICE

*There will be temporary reduction in capacity when frost / ice accumulates on the outside surface of the outdoor unit heat exchanger. The level of capacity reduction depends on a number of factors, for example, outdoor temperature (°F DB), relative humidity (RH), and the amount of frost present.*

## Check the Indoor and Outdoor Unit Selection(s)

Compare the corrected cooling and heating capacities to the load calculations. Is each capacity sufficient for the zone it serves?

For each indoor unit, the corrected capacity must be at least equal to the total of the cooling design load (plus ventilation load, if applicable) for the space(s) served by the indoor unit. For each indoor unit, the corrected capacity also must be at least equal to the total of the heating design load (plus ventilation load, if applicable) for the space(s) and / or thermal zones served by the indoor unit.

The outdoor unit selected must be large enough to offset the total cooling load for all spaces it serves (account for ventilation air cooling load if the ventilation air has not been pretreated to room neutral conditions). The outdoor unit must also be large enough to offset the total heating load for all spaces it serves.

If the corrected heating capacity ratio exceeds 100%, reselect the equipment, or change the system design by moving some of the load to another system.

## System Sizing Check Formulas

### 1. Outdoor Unit Rated Capacity.

$Q_{odu(rated)}$  (From capacity tables).

### 2. Outdoor Unit Capacity at $T_i$ , $T_o$ Temperature.

$Q_{odu(T_i, T_o)}$  (From capacity tables).

### 3 Outdoor Unit Capacity Coefficient Factor.

$$F_{(T_i, T_o)} = Q_{odu(T_i, T_o)} / Q_{odu(rated)}$$

### 4. Piping Correction Factor (From Capacity Coefficient Factor Tables).

$F_{(length)}$  for each piping length

### 5. Individual Indoor Unit Combination Capacity.

$$Q_{idu( combi)} = Q_{odu(rated)} \times Q_{idu(rated)} / Q_{idu(rated-total)}$$

### 6. Individual Indoor Unit Actual Capacity.

$$Q_{idu( actual)} = Q_{odu( combi)} \times F_{(T_i, T_o)} \times F_{(length, altitude)}$$

## Conclusions and Recommendations

- Understand the design safety factors.
- Reference load calculations for actual cooling and heating capacities (applies in 99% of applications – consider total load when latent load is greater than 30%).
- Verify that the sensible load of the zone is satisfied.
- Use caution when sizing to meet listed capacity specifications for the scheduled manufacturer's equipment.

If further system design assistance is needed, or you have a unique application you would like to discuss, contact your LG sales rep.

## Selecting the Best Location for the Indoor Units

### NOTICE

Select a location for installing the indoor units that will meet the following conditions:

- Indoor Units (IDUs) must not be placed in an environment where the IDUs will be exposed to harmful volatile organic compounds (VOCs) or in environments where there is improper air make up or supply or inadequate ventilation. If there are concerns about VOCs in the environment where the IDUs are installed, proper air make up or supply and/ or adequate ventilation must be provided. Additionally, in buildings where IDUs will be exposed to VOCs consider a factory-applied epoxy coating to the fan coils for each IDU.
- Within allowable parameters for proper connection to the outdoor unit (or Branch Distribution unit, if a Multi F MAX system).
- So that condensation drainage can be conveniently routed away.
- Include enough space around the indoor unit so that it is accessible for maintenance and service purposes.
- Where electrical noise / electromagnetic waves will not affect indoor unit operation. Maintain proper distances between the indoor units and electric wires, audio and visual appliances, breaker / circuit panels, etc. If the frequency signal of the appliance is unstable, then install the indoor unit a minimum of ten (10) feet away, and run the power and transmission cables through a conduit.
- An area that is level and with enough strength to bear the weight of the indoor unit(s).
- No obstacles to air circulation around the unit; keep proper distances from ceilings, doorways, floor, walls, etc.
- An area where operation sound won't disturb occupants.
- An area that does not expose the indoor unit(s) to heat, water, steam, oil splattering or spray.

## Selecting the Best Location for the Branch Distribution (BD) Unit

### NOTICE

Branch Distribution (BD) units are used only with Multi F MAX / Multi F MAX with LGRED systems to distribute the refrigerant from the outdoor unit to up to eight indoor units. Select location indoors that will meet the following conditions:

- Within allowable parameters for proper connection to the Multi F MAX / Multi F MAX with LGRED outdoor unit and indoor unit(s); refrigerant piping and wire lengths must not exceed amounts specified by LG Electronics, U.S.A., Inc.
- Condensate drain piping is not required.
- Ensure there is enough space in the installation area for service purposes; install the refrigerant piping and electrical wiring system in an easily accessible location.
- Level where there is enough strength to bear the weight of the BD unit.
- ⓧ Do not install the BD unit in a location where it would be subjected to strong radiation heat from heat sources.
- ⓧ Avoid an installation environment where the BD unit would be exposed to heat, water, steam, oil splattering or spray.
- Install the unit in a location where any sound it generates will not disturb occupants in the surrounding rooms.
- No obstacles to air circulation around the unit; keep proper distances from ceilings, doorways, floor, walls, etc.
- Where high-frequency electrical noise / electromagnetic waves will not affect operation. Maintain proper distances between the BD unit(s) and electric wires, audio and visual appliances, breaker / circuit panels, etc.

## Selecting the Best Location for the Outdoor Unit

### ⚠ DANGER

To avoid the possibility of fire, ⓧ do not install the unit in an area where combustible gas will generate, flow, stagnate, or leak. Failure to do so will cause serious bodily injury or death.

### ⚠ WARNING

ⓧ Do not install the unit in a location where acidic solution and spray (sulfur) are often used as this will cause serious bodily injury or death. ⓧ Do not use the unit in environments where oil, steam, or sulfuric gas are present as this will cause serious bodily injury or death.

### ⚠ CAUTION

When deciding on a location to place the outdoor unit, be sure to choose an area where run-off from defrost will not accumulate and freeze on sidewalks or driveways which will create unsafe conditions.

### NOTICE

Select a location for installing the outdoor unit that will meet the following general conditions:

- A location strong enough to bear the weight of the outdoor unit.
- A location that allows for optimum air flow and is easily accessible for inspection, maintenance, and service.

## Selecting the Best Location for the Outdoor Unit, continued.

- Where piping between the outdoor unit, indoor unit(s), and BD units (Multi F MAX systems only) are within allowable limits.
- Include space for drainage to ensure condensate flows properly out of the unit when it is in heating mode. ⓧ Avoid placing the outdoor unit in a low-lying area where water could accumulate.



- Where it will not be subjected to direct thermal radiation from other heat sources, nor an area that would not expose the outdoor unit to heat or steam like discharge from boiler stacks, chimneys, steam relief ports, other air conditioning units, kitchen vents, plumbing vents, and other sources of extreme temperatures.
- Where high-frequency electrical noise / electromagnetic waves will not affect operation.
- Where operating sound from the unit will not disturb inhabitants of surrounding buildings.
- Where the unit will not be exposed to direct, strong winds.

### Rooftop Installations

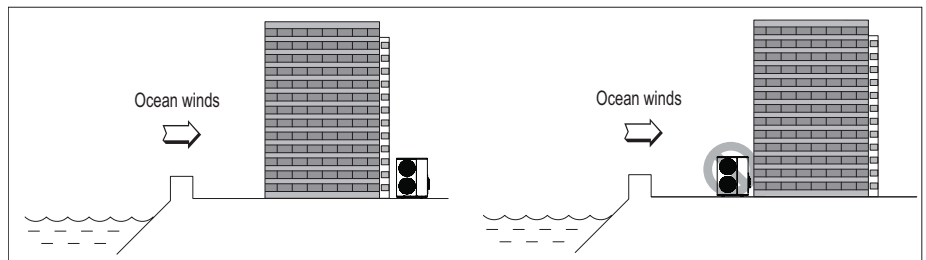
If the outdoor unit is installed on a roof structure, be sure to level the unit. Ensure the roof structure and anchoring method are adequate for the unit location. Consult local codes regarding rooftop mounting.

### Oceanside Installation Precautions

- Install the outdoor unit on the side of the building opposite from direct ocean winds.
- Select a location with good drainage.
- Periodically clean dust or salt particles off of the heat exchanger with water.
- ⓧ Avoid installing the outdoor unit where it would be directly exposed to ocean winds.

### NOTICE

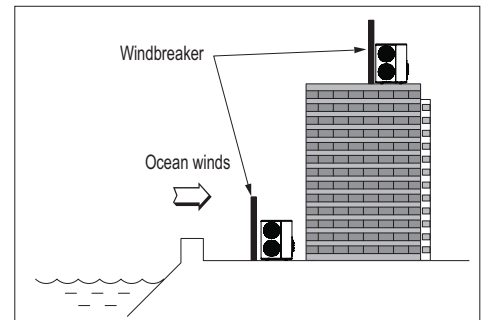
*Ocean winds will cause corrosion, particularly on the condenser and evaporator fins, which, in turn could cause product malfunction or inefficient performance.*



### NOTICE

*Additional anti-corrosion treatment will need to be applied to the outdoor unit at oceanside locations.*

If the outdoor unit must be placed in a location where it would be subjected to direct ocean winds, install a concrete windbreaker strong enough to block any winds. Windbreaker height and width must be more than 150% of the outdoor unit, and be installed at least 27-1/2 inches away from the outdoor unit to allow for airflow.



### Planning for Snow and Ice

In climates that experience snow buildup, place the unit on a raised platform to ensure proper condenser airflow. The raised support platform must be high enough to allow the unit to remain above possible snow drifts. Mount the unit on a field-provided stand that is higher than the maximum anticipated snowfall for the location. Design the mounting base to prevent snow accumulation on the platform in front or back of the unit case. If necessary, provide a field fabricated hood to keep snow and ice and/or drifting snow from accumulating on the coil surfaces. Use inlet and discharge duct or hoods to prevent snow or rain from accumulating on the fan inlet and outlet guards. Best practice prevents snow from accumulating on top of the unit. Consider tie-down requirements in case of high winds or where required by local codes.

## Tie-Downs and Lightening Protection

### Tie-Downs

- The strength of the roof must be checked before installing the outdoor units.
- If the installation site is prone to high winds or earthquakes, when installing on the wall or roof, securely anchor the mounting base using a field-provided tie-down configuration approved by a local professional engineer.
- The overall tie-down configuration must be approved by a local professional engineer. Always refer to local code when using a wind restraint system.

### Lightening Protection

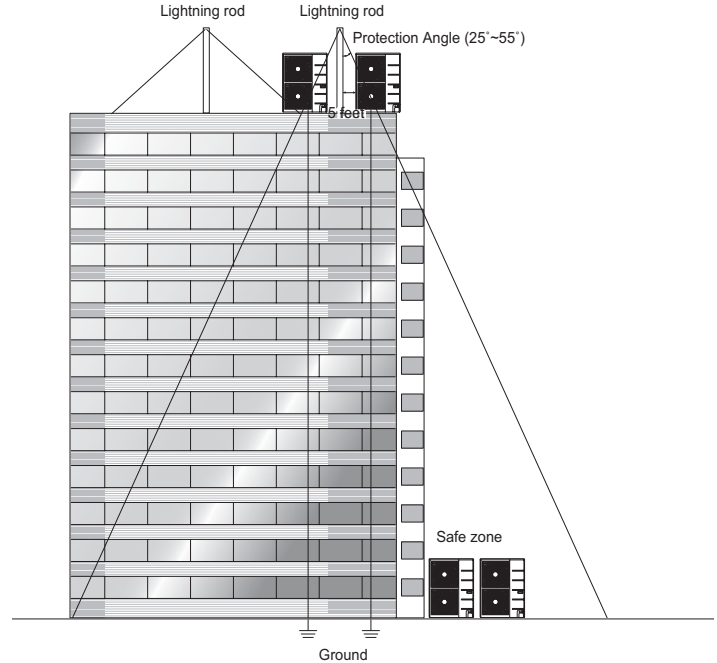
- To protect the outdoor unit from lightning, it must be placed within the specified lightning safety zone.

Table 133: Safety Zone Specifications.

Building Height (feet)	66	98	148	197
Protection Angle (°)	55	45	35	25

- Power cable and communication cable must be installed five (5) feet away from lightning rod.
- A high-resistance ground system must be included to protect against induced lightning or indirect strike.

Figure 277: Lightening Protection Diagram.



### NOTICE

*If the building does not include lightning protection, the outdoor unit will be damaged from a lightning strike. Inform the customer of this possibility in advance.*

## Minimum Allowable Clearance and Service Access Requirements

Proper clearance for the outdoor unit coil is critical for proper unit operation. When installing the outdoor unit, consider service, inlet and outlet and minimum allowable space requirements as illustrated in the diagrams below and on the following pages.

- Include enough space for airflow and for service access. If installing multiple outdoor units, ⚠ avoid placing the units where the discharge of one unit will blow into the inlet side of an adjacent unit.
- If an awning is built over the unit to prevent direct sunlight or rain exposure, make sure that the discharge air of the outdoor unit isn't restricted.
- ⚠ No obstacles to air circulation around the unit; keep proper distances from ceilings, fences, floor, walls, etc. (Install a fence to prevent pests from damaging the unit or unauthorized individuals from accessing it.)

### Minimum Clearance Requirements for Multi F Single Fan Outdoor Units

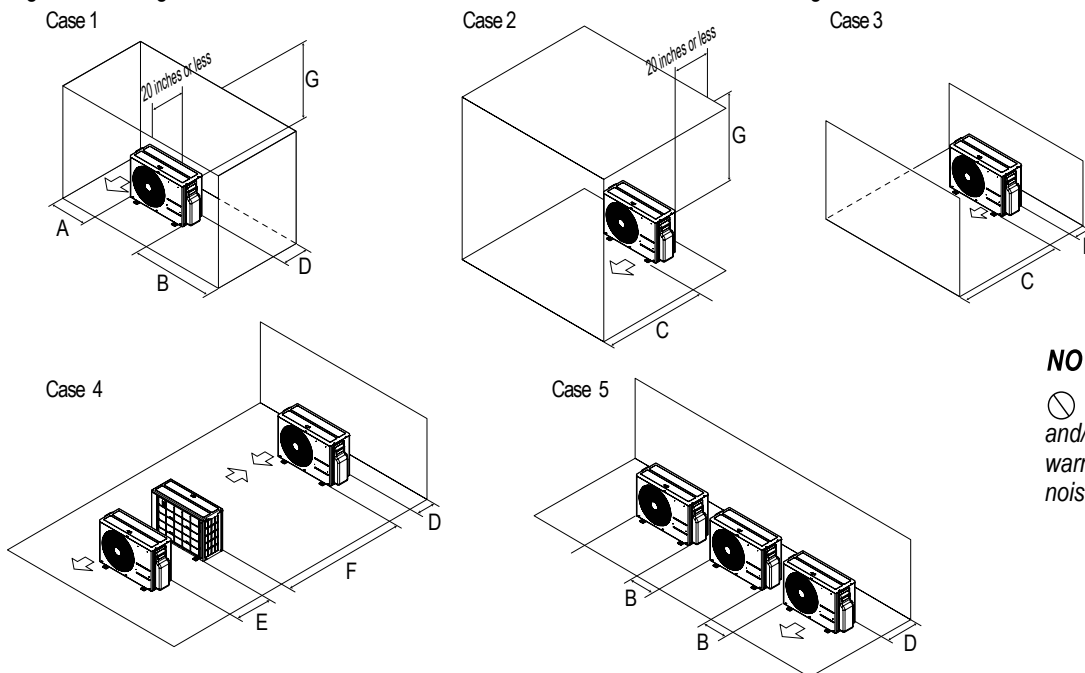
Specific clearance requirements in the diagram below are for single fan outdoor units. The figure below shows the overall minimum clearances that must be observed for safe operation and adequate airflow around the outdoor unit.

When placing the outdoor unit under an overhang, awning, sunroof or other "roof-like structure", observe the clearance requirements (as shown in Cases 1 and 2 for height in relation to the unit). To have successful service access to the outdoor unit, see the figure below for minimum spacing. When installing multiple outdoor units, see Cases 4 and 5 for correct spacing requirements.

#### NOTICE

If the outdoor unit is installed between standard and minimum clearances, capacity decreases approximately 10%.

Figure 278: Single Fan Outdoor Unit Service Access and Allowable Clearances Diagram.



#### NOTICE

⚠ Do not place the unit where animals and/or plants will be in the path of the warm air, or where the warm air and / or noise will disturb neighbors.

Table 134: Single Fan Outdoor Unit Service Access and Allowable Clearances Diagram Legend.

Unit: Inch		A	B	C	D	E	F	G
Case 1	Standard	12	24	-	12	-	-	-
	Minimum	4	10	-	4	-	-	40
Case 2	Standard	-	-	20	-	-	-	-
	Minimum	-	-	14	-	-	-	40
Case 3	Standard	-	-	20	12	-	-	-
	Minimum	-	-	14	4	-	-	-
Case 4	Standard	-	-	-	12	24	-	-
	Minimum	-	-	-	4	8	79	-
Case 5	Standard	-	24	-	12	-	-	-
	Minimum	-	10	-	4	-	-	-

# PLACEMENT CONSIDERATIONS

MULTI F  
MULTI F MAX

## Minimum Clearance Requirements for Dual Fan Outdoor Units

Figures below and on the next page illustrate clearance requirements for various installation scenarios for dual fan outdoor units. Use the hot isle / cold isle approach when placing multiple units in close proximity to each other. Outdoor unit fans draw air from the back of the unit and discharges out the front. Place units back to back and face to face.

### NOTICE

- Installation clearances must comply with local building codes.
- All figures not to scale.
- ⚠ Never place multiple units facing back to front or front to back as shown in Figure 279 or high and low system pressure problems will occur.

Figure 279: Improper Outdoor Unit Placement.

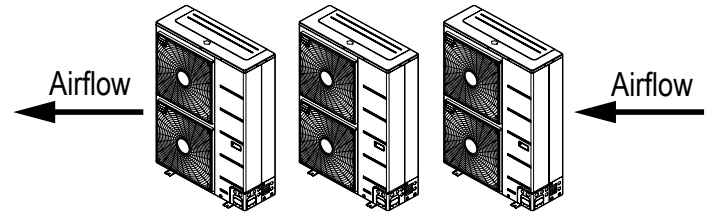
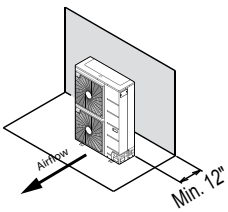
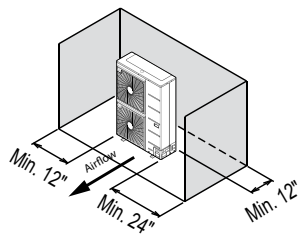


Figure 280: Proper Outdoor Unit Placement and Clearances When There Are Obstacles on the Suction Side.

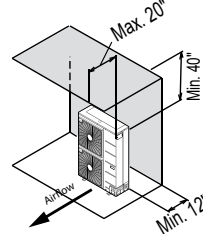
Single Unit—High Rear Wall



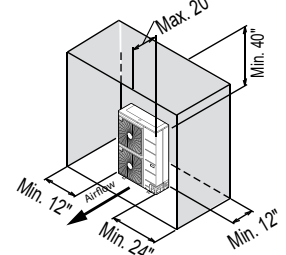
Single Unit—High Rear Wall with High Side Walls



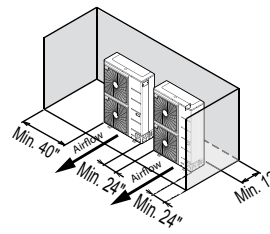
Single Unit—High Rear Wall with Building Overhang



Single Unit—High Rear and Side Walls with Building Overhang



Side by Side—High Rear and Side Walls



Side by Side—High Rear and Side Walls with Building Overhang

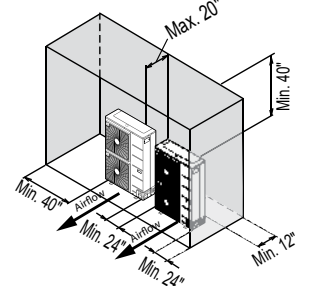
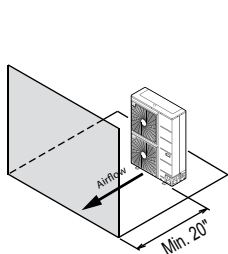
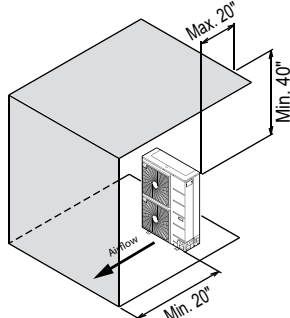


Figure 281: Proper Outdoor Unit Placement and Clearances When There Are Obstacles on the Discharge Side.

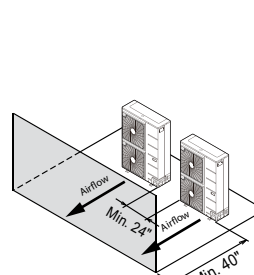
Single Unit—High Front Wall with No Side Walls



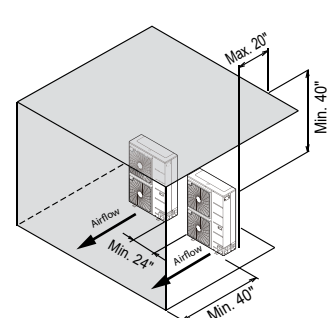
Single Unit—High Front Wall with Building Overhang and No Side Walls



Side by Side—High Front Wall with No Side Walls



Side by Side—High Front Wall with Building Overhang and No Side or Rear Walls



## Minimum Clearance Requirements for Dual Fan Outdoor Units, Continued.

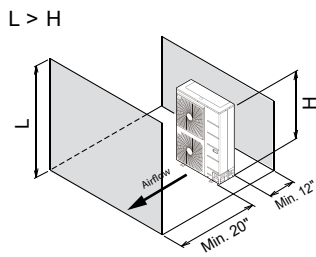
### NOTICE

- Installation clearances must comply with local building codes.
- All figures not to scale.

Figure 282: Proper Outdoor Unit Placement and Clearances When There Are Obstacles on the Suction and the Discharge Sides.

When Obstacle Height of the Discharge Side is Higher than the Outdoor Unit.

Single Unit—High Rear and Front Walls with No Side Walls



Single Unit—High Rear and Front Walls with Building Overhang

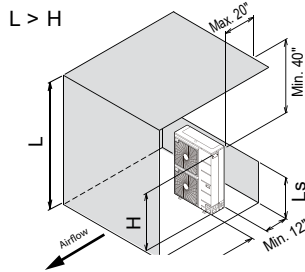


Table 135: H, A, and L Ratio.

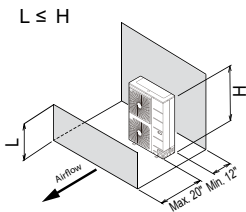
	Ls	A (Inches)
L ≤ H	0 < Ls ≤ 1/2 H	30
	1/2 H < Ls	40
H < L	Set Stand as: L ≤ H	

### NOTICE

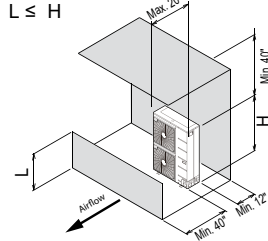
"L" must be lower than "H". If a stand is necessary, it must be made of solid material (not an open frame) to prevent the discharge air from short cycling.

Obstacle Height of Discharge Side Is Lower than the Outdoor Unit.

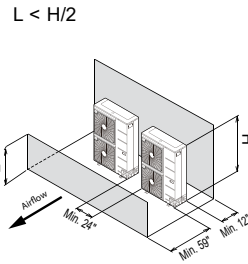
Single Unit—High Rear Wall and Low Front Wall with No Side Walls



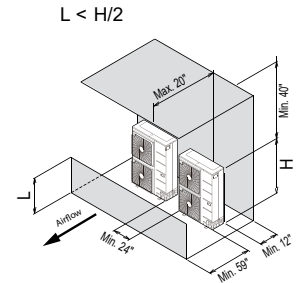
Single Unit—High Rear Wall and Low Front Wall with Building Overhang and No Side Walls



Side by Side—High Rear Wall and Low Front Wall with No Side Walls

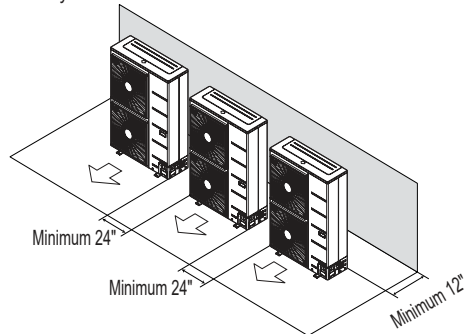


Side by Side—High Rear Wall and Low Front Wall with Building Overhang and No Side Walls

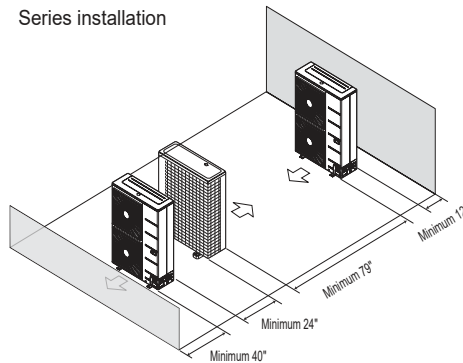


### Series Installation

Side-by-side series installation.



Series installation



# REFRIGERANT PIPING DESIGN & LAYOUT BEST PRACTICES

**Design Guideline Summary on page 233**

**Creating a Balanced System / Manual Layout Procedure on page 237**

**Condensate Drain Piping on page 238**

The following are examples of manual pipe size calculations. Designers are highly encouraged to use LATS for Multi F systems.

### Device Connection Limitations

- The minimum number of connected and operating indoor units to Multi F / Multi F MAX systems is two, taking into consideration of the minimum combination ratio.
- The maximum number of indoor units for each Multi F / Multi F MAX heat pump systems is:

KUMXB181A = 2    KUMXB241A = 3    KUMXB301A = 4    KUMXB361A = 4    KUMXB481A = 8    KUMXB541A = 8    KUMXB601A = 8  
 KUMXA181A = 2    KUMXA241A = 3    KUMXA301A = 4    KUMXA361A = 5    KUMXA421A = 6    KUMXA481A = 8

One of the most critical elements of multi-zone systems is the refrigerant piping. The following pages list pipe length limits that must be followed in the design of Multi F and Multi F MAX refrigerant pipe systems:

### Using Refrigerant Components

Field-supplied elbows are allowed as long as they are designed for use with R32 refrigerant. The designer, however, must be cautious with the quantity and size of fittings used, and must account for the additional pressure losses in equivalent pipe length calculation for each branch. The equivalent pipe length of each elbow must be added to each pipe segment.

Table 136: Equivalent Piping Length for Elbows, Y-branches, and Branch Distribution Units.

Component	Size (Inches)				
	1/4	3/8	1/2	5/8	3/4
Elbow (ft.)	0.5	0.6	0.7	0.8	1.2
Y-Branch Kit (ft., Multi F MAX systems only) <sup>1</sup>	1.6				
Branch Distribution Unit (ft., Multi F MAX systems only)	8.2				

<sup>1</sup>Kit contains two Y-branches: one for liquid and one for vapor.

### Multi F System

Example: KUMXB361A outdoor unit with four (4) indoor units connected.

ODU: Outdoor Unit.

IDU: Indoor Unit.

A, B, C, D: Pipes from Outdoor Unit to Indoor Unit.

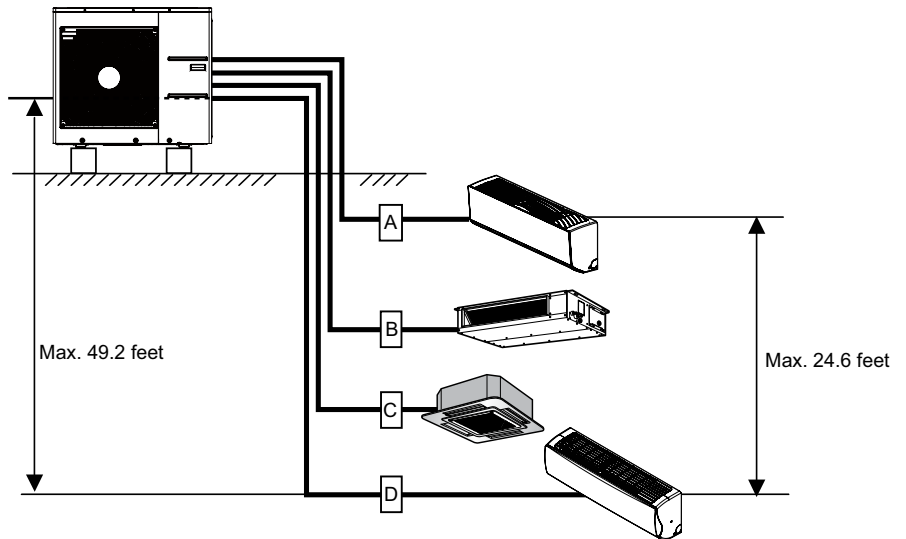


Table 137: Multi F Outdoor Unit Refrigerant Piping System Limitations.

Outdoor Unit	Minimum Length for Each Pipe (ft.)	Maximum Piping Length to Each Indoor Unit (ft.)				Maximum Total Piping Length for Each System (ft.)	Maximum Height Difference (Max. [ft.]) Outdoor Unit ~ Indoor Unit	Maximum Height Difference (Max. [ft.]) Indoor Unit ~ Indoor Unit
		A	B	C	D			
KUMXB181A	10	82	82	-	-	164.0	49.2	24.6
KUMXB241A	10	82	82	82	-	230.0	49.2	24.6
KUMXB301A	10	82	82	82	82	246.1	49.2	24.6
KUMXB361A	10	82	82	82	82	246.1	49.2	24.6

# REFRIGERANT PIPING DESIGN

MULTI F  
MULTI F MAX

## Design Guideline Summary

The following are examples of manual pipe size calculations. Designers are highly encouraged to use LATS for Multi F systems.

### Multi F MAX System with One Branch Distribution Unit

Example: KUMXB541A outdoor unit with four (4) indoor units, and one (1) branch distribution unit connected.

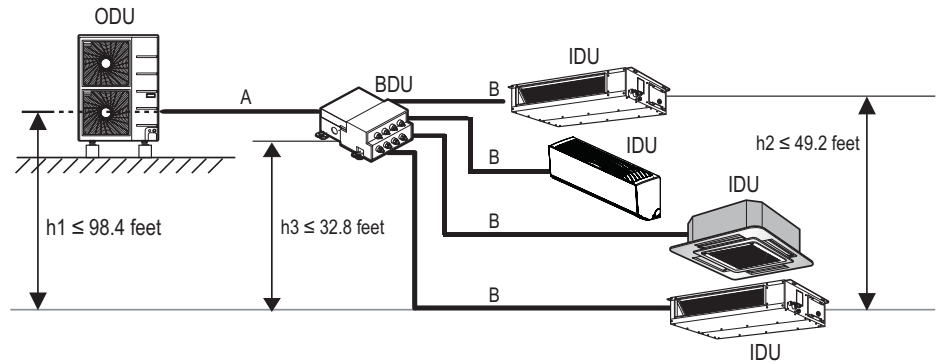
ODU: Outdoor Unit.

IDU: Indoor Unit.

BDU: Branch Distribution Unit.

A: Main Pipe.

B: Branch Pipe (Branch Distribution Unit to Indoor Unit[s]).



### Multi F MAX System with Two Branch Distribution Units

Example: KUMXB541A outdoor unit with seven (7) indoor units, and two (2) branch distribution units connected.

ODU: Outdoor Unit.

IDU: Indoor Unit.

BD: Branch Distribution Unit(s).

$\Sigma A$ : Main Pipe.

$\Sigma B$ : Branch Pipe (Branch Distribution Unit[s] to Indoor Unit[s]).

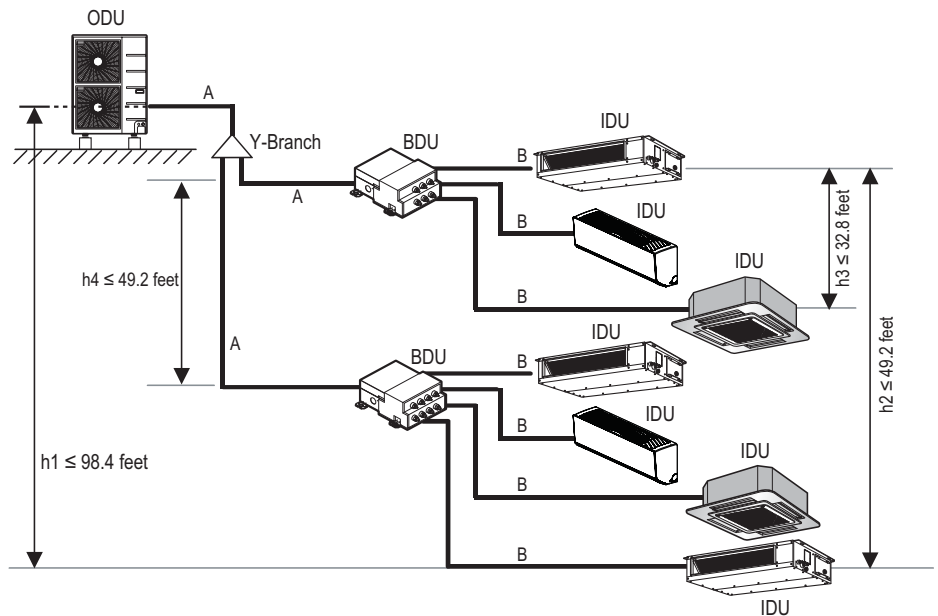


Table 138: Multi F MAX Outdoor Unit Refrigerant Piping System Limitations.

Pipe Length (ELF = Equivalent Length of pipe in Feet)	Total piping length ( $\Sigma A + \Sigma B$ )		≤475.7 feet
	Main pipe (Outdoor Unit to Branch Distribution Units: $\Sigma A$ )	Minimum	16.4 feet
		Maximum	≤180.4 feet
	Total branch piping length ( $\Sigma B$ )		≤295.3 feet
Branch pipe (Branch Distribution Units to Indoor Units: B)	Minimum	16.4 feet	
	Maximum	≤49.2 feet	
Elevation Differential (All Elevation Limitations are Measured in Actual Feet)	If outdoor unit is above or below indoor unit (h1)		≤98.4 feet
	Between the farthest two indoor units (h2)		≤49.2 feet
	Between branch distribution unit and farthest connected indoor unit(s) (h3)		≤32.8 feet
	Between branch distribution units (h4)		≤49.2 feet

Table 139: Multi F MAX Piping Sizes.

Piping	Main Pipe A (inch)	Branch Pipe B
Liquid	Ø3/8	Depends on the size of the indoor unit piping
Gas	Ø3/4	

The following are examples of manual pipe size calculations. Designers are highly encouraged to use LATS for Multi F systems.

### Multi F with LGRED System

Example: KUMXA301A outdoor unit with four (4) indoor units connected.

ODU: Outdoor Unit.

IDU: Indoor Unit.

A, B, C, D: Pipes from Outdoor Unit to Indoor Unit.

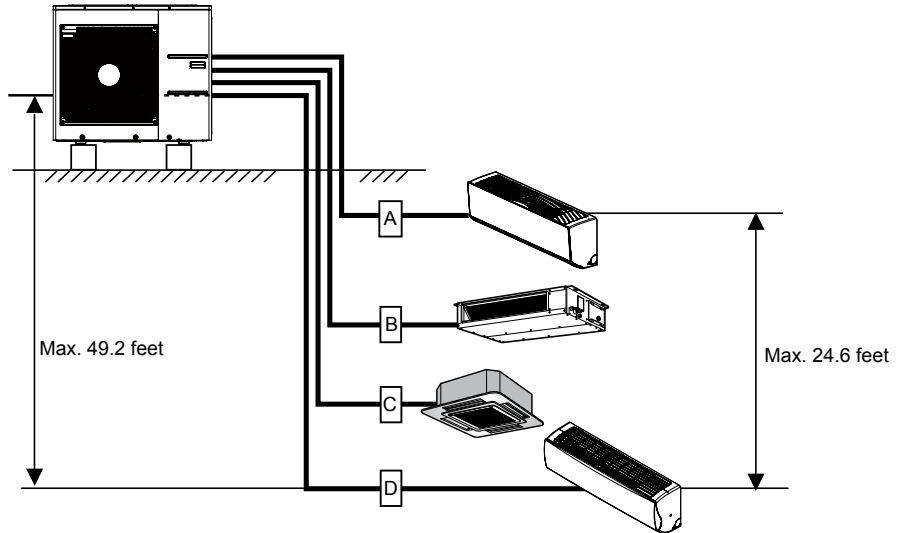


Table 140: Multi F with LGRED Outdoor Unit Refrigerant Piping System Limitations.

Outdoor Unit	Minimum Length for Each Pipe (ft.)	Maximum Piping Length to Each Indoor Unit (ft.)				Maximum Total Piping Length for Each System (ft.)	Maximum Height Difference (Max. [ft.]) Outdoor Unit ~ Indoor Unit	Maximum Height Difference (Max. [ft.]) Indoor Unit ~ Indoor Unit
		A	B	C	D			
KUMXA181A	10	82	82	-	-	164.0	49.2	24.6
KUMXA241A	10	82	82	82	-	246.1	49.2	24.6
KUMXA301A	10	82	82	82	82	246.1	49.2	24.6

### Multi F MAX with LGRED System with One Branch Distribution Unit

Example: KUMXA361A outdoor unit with four (4) indoor units and one (1) branch distribution unit connected.

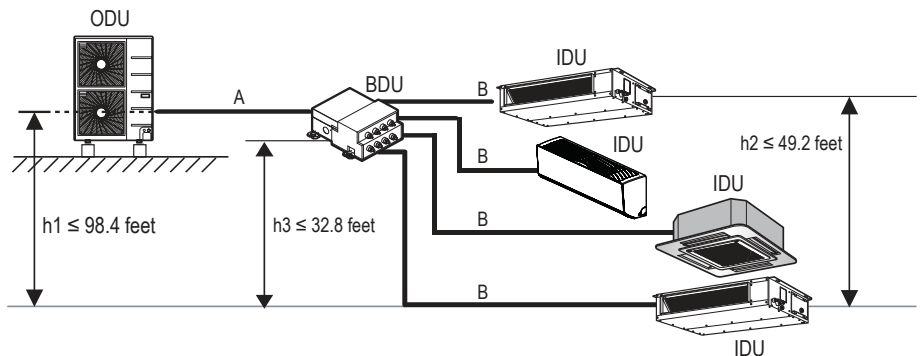
ODU: Outdoor Unit.

IDU: Indoor Unit.

BDU: Branch Distribution Unit.

A: Main Pipe.

B: Branch Pipe (Branch Distribution Unit to Indoor Unit[s]).



# REFRIGERANT PIPING DESIGN

## Design Guideline Summary

MULTI F  
MULTI F MAX

The following are examples of manual pipe size calculations. Designers are highly encouraged to use LATS for Multi F systems.

### Multi F MAX with LGRED System with Two Branch Distribution Units

**Example: KUMXA421A outdoor unit with six (6) indoor units and two (2) branch distribution units connected.**

ODU: Outdoor Unit.

IDU: Indoor Unit.

BDU: Branch Distribution Unit(s).

$\Sigma A$ : Main Pipe.

$\Sigma B$ : Branch Pipe (Branch Distribution Unit[s] to Indoor Unit[s]).

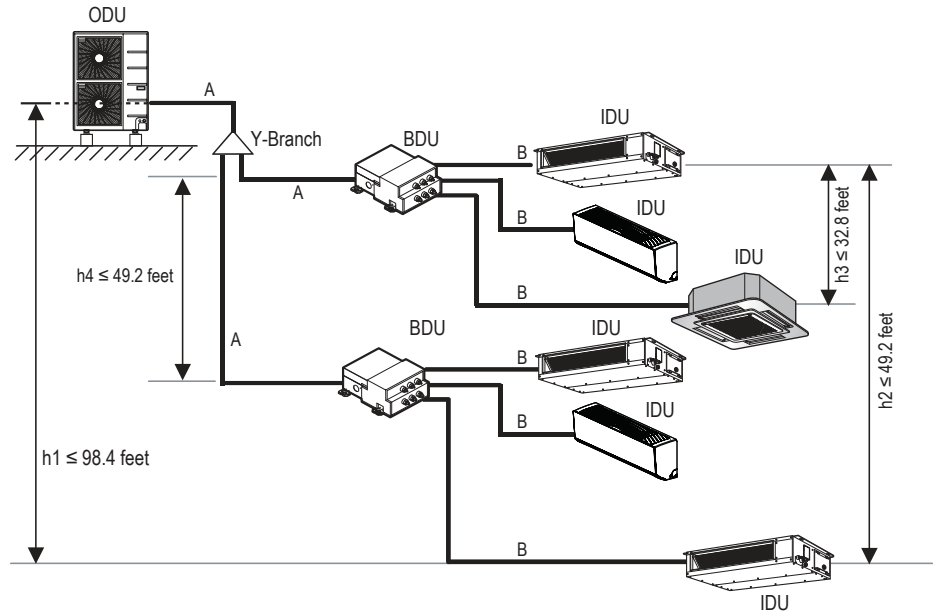


Table 141: Multi F MAX with LGRED Outdoor Unit Refrigerant Piping System Limitations.

Pipe Length (ELF = Equivalent Length of pipe in Feet)	Total piping length ( $\Sigma A + \Sigma B$ )		≤475.7 feet
	Main pipe (Outdoor Unit to Branch Distribution Units: $\Sigma A$ )	Minimum	16.4 feet
Maximum		≤180.4 feet	
Total branch piping length ( $\Sigma B$ )			≤295.3 feet
	Branch pipe (Branch Distribution Units to Indoor Units: B)	Minimum	16.4 feet
Maximum		≤49.2 feet	
Elevation Differential (All Elevation Limitations are Measured in Actual Feet)	If outdoor unit is above or below indoor unit (h1)		≤98.4 feet
	Between the farthest two indoor units (h2)		≤49.2 feet
	Between branch distribution unit and farthest connected indoor unit(s) (h3)		≤32.8 feet
	Between branch distribution units (h4)		≤49.2 feet

Table 142: Multi F MAX with LGRED Piping Sizes.

Piping	Main Pipe A (inch)	Branch Pipe B
Liquid	Ø3/8	Depends on the size of the indoor unit piping
Gas	Ø3/4	

---

---

## Creating a Balanced / Quality Piping System

Unlike designing duct-work or chilled and hot water pipe systems where balancing dampers, ball valves, orifices, circuit setters, or other flow control devices can be installed to modify or balance the flow of cooling medium, these cannot be used in a Multi F system. Therefore, variable refrigerant flow systems have to be designed to be “self balanced.” Balanced liquid refrigerant distribution is solely dependent on the designer using the correct pipe size for each segment. Pipe sizing considerations include pipe length, pipe segment pressure drop relative to other pipe segments in the system, type and quantity of elbows, bends present, fitting installation orientation, and end use device elevation differences.

### NOTICE

⚠ The designer must avoid creating excessive pressure drop. When liquid refrigerant is subjected to excessive pressure drop, liquid refrigerant will change state and “flash” to vapor. Vapor present in a stream of liquid refrigerant before reaching the indoor unit coil (or branch distribution unit for Multi F MAX systems) results in a loss of system control and causes damage to the components. ⚠ The pipe system must be designed in a manner that avoids the creation of unwanted vapor.

## Refrigerant Piping System Verification

To ensure that the refrigerant piping design is suitable for the system, a LATS refrigerant piping design software report must be provided with every Multi F order. Following the installation, if any changes or variations to the design were necessary, an “as-built” LATS piping design software report must be provided to LG prior to system commissioning. User must always check the LATS report actual pipe layout versus pipe limits.

### NOTICE

*Any field changes, such as re-routing, shortening or lengthening a pipe segment, adding or eliminating elbows and/or fittings, re-sizing, adding, or eliminating indoor units, changing the mounting height or moving the location of a device or fitting during installation must be done with caution and ALWAYS VERIFIED in LATS HVAC SOFTWARE before supplies are purchased or installed. Doing so ensures profitable installation, eliminates rework, and ensures easier system commissioning.*

## Manual Layout Procedure

1. Choose the location of the indoor units on the building drawing.
2. Choose the location of all Y-branch and branch distribution units (if a Multi F MAX system) and note them on the building drawing. Verify that all fittings are positioned per the guideline limitations in “LG Engineered Multi F MAX Y-Branch Kit”
3. Plan the route for interconnecting piping. Draw a one-line depiction of the pipe route chosen on the building drawing.
4. Calculate the actual length of each pipe segment and note it on the building drawing.
5. Using the data obtained while selecting the system components, list the corrected cooling capacity next to each indoor unit on the drawing.
6. Starting at the indoor unit located farthest from the outdoor unit, sum the corrected cooling capacity of all indoor units served by the pipe segment for each branch and runout pipe (indoor units and branch distribution units [Multi F MAX systems only]). Record these values next to each segment.
7. Verify the size of the liquid and vapor lines.
8. If a Multi F MAX system, refer to the branch distribution unit information and the Y-branch kit information to verify the part number of each Y-branch and branch distribution unit based on the connected downstream nominal capacity served.
9. Calculate the equivalent pipe length in feet of each pipe segment. If a Multi F MAX system, Y-branch equivalent lengths must be totaled with the upstream segment only. Use equivalent pipe length data when it is provided with field-purchased fittings. If not available, use the data provided to estimate the equivalent length of field-provided pipe and fittings for each segment. Equivalent lengths must be totaled with the upstream segment only.
10. Verify the equivalent pipe length complies with product limitations. If the limitations are exceeded, either reroute the pipe or change the location of the indoor unit, Y-branch fittings and branch distribution units (if Multi F MAX systems), so the design conforms with all limitations.
11. If pipe length is adjusted as described in Step 10 above, verify again if the length of the design complies with the product limitations.
12. Use LATS HVAC software to verify the manually sized pipe design is acceptable. When entering the length of pipe segments in LATS HVAC software, enter the equivalent pipe length. Account for the additional pressure drop created by elbows, valves, and other fittings present in each segment by adding their respective equivalent pipe length to the actual pipe length.

### Condensate Drain Piping

#### Indoor Units

All indoor units generate water during cooling operation, therefore, how to properly handle this condensation must be considered. Some indoor units include factory-installed drain pumps; others apply the gravity drain method.

Table 143: Indoor Unit Drain Piping Specifications.

Indoor Unit	Drain Type	Drain Pipe Diameter (OD / ID, in.)	Drain Amount (gal. / min. at 0.033 ft. height)
Art Cool Wall-Mounted	Gravity	13/16 / 5/8	—
High Efficiency Wall-Mounted	Gravity	13/16 / 5/8	—
Low Wall Console	Gravity	13/16 / 5/8	—
Low Static Duct and High Static Duct	27-1/2 in. Lift Drain Pump, Factory Installed	Ø1-1/4 / Ø1	0.105
Convertible Mid Static Duct	27-1/2 in. Lift Drain Pump, Factory Installed	Ø1-1/4 / Ø31/32	0.105
Four-Way Ceiling Cassette	27-1/2 in. Lift Drain Pump, Factory Installed	Ø1-1/4 / Ø1	0.105
Multi Position Air Handling Unit	Gravity	Ø3/4 / —	—

Figure 283: Diagram of an Indoor Unit with a Gravity Drain.

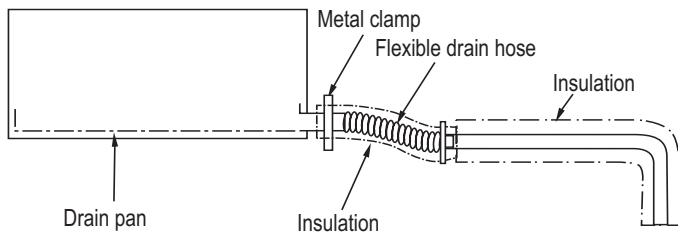
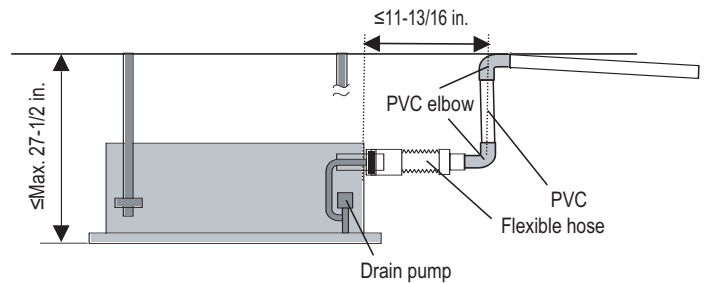


Figure 284: Diagram of an Indoor Unit with a Drain Pump.



# ELECTRICAL CONNECTIONS

**General Information on page 240**

**Multi F Systems on page 244**

**Multi F MAX Systems on page 246**

**Multi F with LGRED Systems on page 247**

**Multi F MAX with LGRED Systems on page 248**

**Remote Controller Connections on page 249**

**Indoor Unit Group Control on page 250**

# ELECTRICAL CONNECTIONS

## General Information

MULTI F  
MULTI F MAX

### **⚠ WARNING**

- All power (line voltage) wiring and communication cable installation must be performed by trained service providers working in accordance with all local, state, and National Electrical Code (NEC) / UL / ETL federal regulations related to electrical equipment and wiring, and following the manufacturer product diagrams, requirements, and instructions in this manual. Electric shock can cause physical injury or death.
- Be sure that main power to the unit is completely off before proceeding. Follow all safety and warning information outlined at the beginning of this manual. Failure to do so will cause electric shock and bodily injury.
- Install a main shutoff switch or circuit breaker that interrupts all power sources simultaneously (circuit breaker must be resistant to electromagnetic currents). Be sure that the circuit breaker or some other emergency power cutoff device is in place before any power wiring is done to the system. Failure to do so will cause bodily injury or death.
- ⓧ Never touch any power lines or live cables before all power is cutoff to the system. To do so will cause bodily injury or death.
- Power wiring and communication cable sizes must comply with all applicable federal, state, and local codes. Undersized wiring will lead to unacceptable voltage at the unit and will cause a fire, which will cause bodily injury or death.
- Properly ground the outdoor unit, indoor units, and branch distribution units. Ground wiring must always be installed by a trained technician. Ground wiring is required to prevent accidental electrical shock during current leakage, which will cause bodily injury or death.
- Verify that the branch switch and circuit breaker are set to OFF before installing the wiring system. Electric shock can cause physical injury or death.
- Install appropriately sized breakers / fuses / overcurrent protection switches and wiring in accordance with local, state, and NEC regulations related to electrical equipment and wiring, and following the instructions in this manual. Generated overcurrent will include some amount of direct current. Using an oversized breaker or fuse will result in electric shock, physical injury or death.
- ⓧ Do not connect ground wire to refrigerant, gas, sewage, or water piping; to lightning rods; to telephone ground wiring; or to the building plumbing system. Failure to properly provide a NEC-approved earth ground can result in electric shock, fire, physical injury or death.

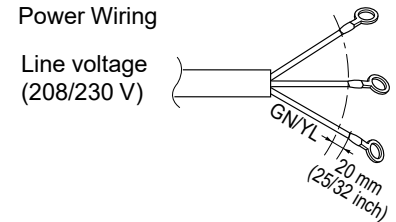
### **NOTICE**

- Consider ambient conditions (temperature, direct sunlight, inclement weather, etc.) when selecting, installing, and connecting the power wiring.
- Properly ground the outdoor unit, indoor units, and branch distribution units. Ground wiring must always be installed by a trained technician. Improperly grounded wire can cause communication problems from electrical noise, and motor current leakage.
- Install appropriately sized breakers / fuses / overcurrent protection switches and wiring in accordance with local, state, and NEC regulations related to electrical equipment and wiring, and following the instructions in this manual. Generated overcurrent will include some amount of direct current. Using an oversized breaker or fuse will result in equipment malfunction and property damage.
- ⓧ Do not connect ground wire to refrigerant, gas, or water piping; to lightning rods; to telephone ground wiring; or to the building plumbing system. Failure to properly provide a NEC-approved earth ground can result in property damage and equipment malfunction.
- ⓧ Do not operate the air conditioning system until the refrigerant piping installation is complete. Operating the system before refrigerant piping is finalized will damage the compressor.

**Power Supply / Power Wiring Specifications to the ODU**

- Multi F and Multi F MAX systems operate at 1Ø, 208-230V, 60Hz, and power is wired to the outdoor unit only.
  - 14 AWG, three (3) conductor for 18,000 and 24,000 Btu/h Multi F capacities.
  - 12 AWG, three (3) conductor for 30,000 and 36,000 Btu/h Multi F capacities.
  - 8 AWG, three (3) conductor for 48,000, 54,000, and 60,000 Btu/h Multi F MAX capacities
- Multi F and Multi F MAX with LGRED systems operate at 1Ø, 208-230V, 60Hz, and power is wired to the outdoor unit only.
  - 12 AWG, three (3) conductor for 18,000, 24,000, and 30,000 Btu/h Multi F with LGRED capacities.
  - 8 AWG, three (3) conductor for 36,000, 42,000 and 48,000 Btu/h Multi F MAX with LGRED capacities.
- Power wiring must be solid or stranded; and comply with all applicable National Electrical Code (NEC), UL, and local electrical codes.
- Wiring is allowed for lengths up to the published maximum piping length, plus recommended slack at both ends (typical slack: 6-12 inches).
- Power supply to the outdoor unit must be selected based on NEC, UL, and local codes Maximum allowable voltage fluctuation ±10% or nameplate rated value.
- Properly ground the outdoor unit and indoor unit per NEC and local codes; ground wire must be longer than the common power / communication wires.
- Firmly connect the wiring so it cannot be easily pulled out.
- Refer to the inside of the chassis cover or control cover for circuit and terminal block diagrams. Always match color codes of each wire and follow wiring diagram.
- Do not install power wiring to the outdoor unit and the power wiring / communication wiring to the indoor unit / branch distribution Unit (Multi F MAX outdoor units only) in the same conduit. Use separate conduits. Always match color codes of each wire and follow wiring diagram.
- ⓧ Do not install power wiring to the outdoor unit and the communication / connection (power) cable to the indoor unit in the same conduit. Use separate conduits.

Figure 285: Multi F / Multi F MAX Outdoor Unit Power Wiring.



**⚠ WARNING**

Always have a trained service provider properly ground the outdoor unit. If the outdoor unit is not properly grounded, there is a risk of electric shock, physical injury, or death.

**Power Wiring / Communications Wiring from the ODU to IDUs / BDUs**

- The outdoor unit supplies power to the indoor units / branch distribution units (Multi F MAX systems only).
- The outdoor unit also supplies communication to the indoor units / branch distribution units (Multi F MAX systems only).
- Wiring from the outdoor units to the indoor units / branch distribution units (Multi F MAX systems only) must be stranded, shielded or unshielded (if shielded, it must be grounded to the chassis of the outdoor unit only), and must comply with all applicable National Electrical Code (NEC), UL, and local electrical codes.
- Insulation material as required by local code.
- Rated for continuous exposure of temperatures up to 140°F.
- Firmly attach the wiring; provide slack at both ends but secure in a way to prevent external forces from being imparted on the terminal block.
- Wiring is allowed for lengths up to the published maximum piping length, plus recommended slack at both ends (typical slack: 6-12 inches).
- Wiring must be completed without splices.
- When the power wire and communication wire length between the outdoor unit and branch distribution unit, and between the branch distribution unit and the indoor units GREATER THAN 130 feet:
  - Use minimum 14 AWG communication wiring
  - OR
  - Separate the power wiring AT LEAST two (2) inches away from the communication wiring.

Figure 286: Power Wiring and Communication Wiring from ODU to IDU / BDU (Multi F MAX Only), and from the BDU to the IDU (Multi F MAX Only).

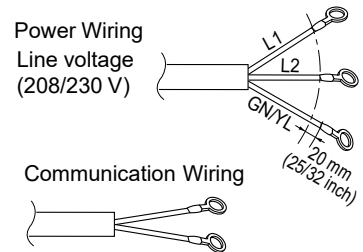
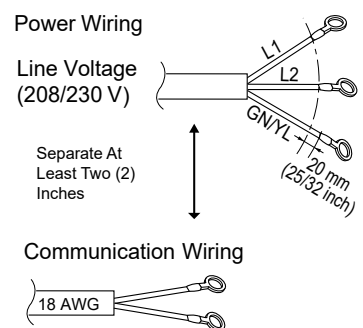


Figure 287: Power Wiring and Communication Wiring from ODU to IDU / BDU (Multi F MAX Only), and from the BDU to the IDU (Multi F MAX Only) GREATER THAN 130 feet



### Multi F / Multi F MAX Power Wiring / Communications Wiring

#### Multi F Systems (Outdoor Unit to Indoor Units):

- Power wiring must be a minimum of 14 AWG, three (3) conductor for 18,000, 24,000, 30,000 and 36,000 Btu/h Multi F capacities.
- Communications wiring must be a minimum of 18 AWG, two (2) conductor for 18,000, 24,000, 30,000 and 36,000 Btu/h Multi F capacities.

#### Multi F MAX Systems (Outdoor Unit to Branch Distribution Units):

- Power wiring must be a minimum of 14 AWG, three (3) conductor for 48,000, 54,000, and 60,000 Btu/h Multi F MAX capacities.
- Communications wiring must be a minimum of 18 AWG, two (2) conductor for 48,000, 54,000, and 60,000 Btu/h Multi F MAX capacities.

#### Multi F MAX Systems (Branch Distribution Units to Indoor Units):

- Power wiring must be a minimum of 14 AWG, three (3) conductor for 48,000, 54,000, and 60,000 Btu/h Multi F MAX capacities.
- Communications wiring must be a minimum of 18 AWG, two (2) conductor for 48,000, 54,000, and 60,000 Btu/h Multi F MAX capacities.

#### NOTICE

- ⚠ Never ground the shield of the communications wiring to the indoor unit / branch distribution unit frame or other grounded entities of the building. Ground the communications wiring shield only at the outdoor unit. Improperly grounding this cable can cause communications errors
- Use a conduit for the power cable and the communications cable from the outdoor unit to the indoor units / branch distribution units. Electrical interference may cause product malfunction.
- The communications wiring from the outdoor unit to the indoor units / branch distribution unit(s) must be separated and isolated from power wiring to the outdoor unit, computers, radio and television broadcasting facilities, as well as medical imaging equipment. Electrical interference may cause product malfunction.

Figure 288: Example of a Multi F System General Power / Communications System Schematic.

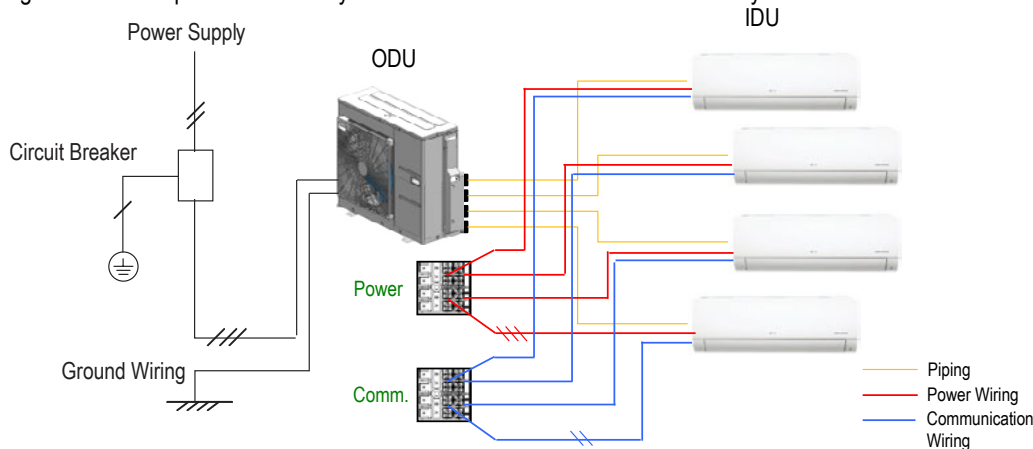
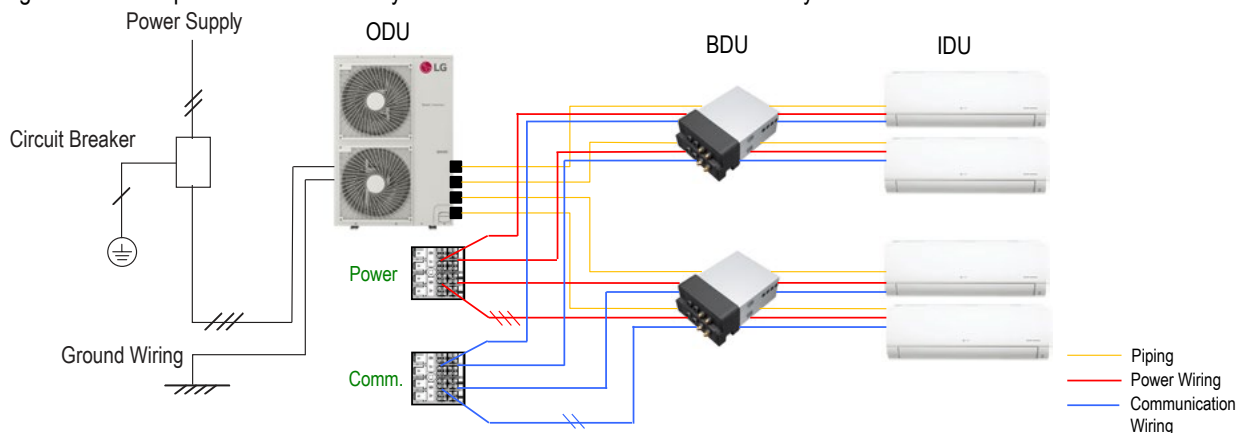


Figure 289: Example of a Multi F MAX System General Power / Communications System Schematic.



Due to our policy of continuous product innovation, some specifications may change without notification.  
©LG Electronics U.S.A., Inc., Englewood Cliffs, NJ. All rights reserved. "LG" is a registered trademark of LG Corp.

**Multi F / Multi F MAX with LGRED Power Wiring / Communications Wiring**

**Multi F with LGRED Systems (Outdoor Unit to Indoor Units):**

- Power wiring must be a minimum of 14 AWG, three (3) conductor for 18,000, 24,000, and 30,000 Btu/h Multi F capacities.
- Communications wiring must be a minimum of 18 AWG, two (2) conductor for 18,000, 24,000, and 30,000 Btu/h Multi F capacities.

**Multi F MAX with LGRED Systems (Outdoor Unit to Branch Distribution Units):**

- Power wiring must be a minimum of 14 AWG, three (3) conductor for 36,000, 42,000, and 48,000 Btu/h Multi F MAX capacities.
- Communications wiring must be a minimum of 18 AWG, two (2) conductor for 36,000, 42,000, and 48,000 Btu/h Multi F MAX capacities.

**Multi F MAX with LGRED Systems (Branch Distribution Units to Indoor Units):**

- Power wiring must be a minimum of 14 AWG, three (3) conductor for 36,000, 42,000, and 48,000 Btu/h Multi F MAX capacities.
- Communications wiring must be a minimum of 18 AWG, two (2) conductor for 36,000, 42,000, and 48,000 Btu/h Multi F MAX capacities.

**NOTICE**


-  Never ground the shield of the communications wiring to the indoor unit / branch distribution unit frame or other grounded entities of the building. Ground the communications wiring shield only at the outdoor unit. Improperly grounding this cable can cause communications errors.
- Use a conduit for the power cable and the communications cable from the outdoor unit to the indoor units / branch distribution units. Electrical interference may cause product malfunction.
- The communications wiring from the outdoor unit to the indoor units / branch distribution unit(s) must be separated and isolated from power wiring to the outdoor unit, computers, radio and television broadcasting facilities, as well as medical imaging equipment. Electrical interference may cause product malfunction.

Figure 290: Example of a Multi F with LGRED System General Power / Communications System Schematic.

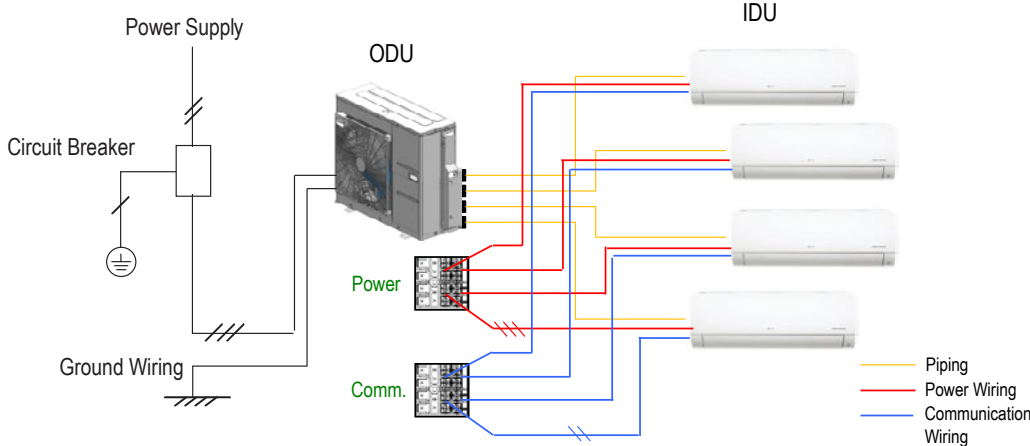
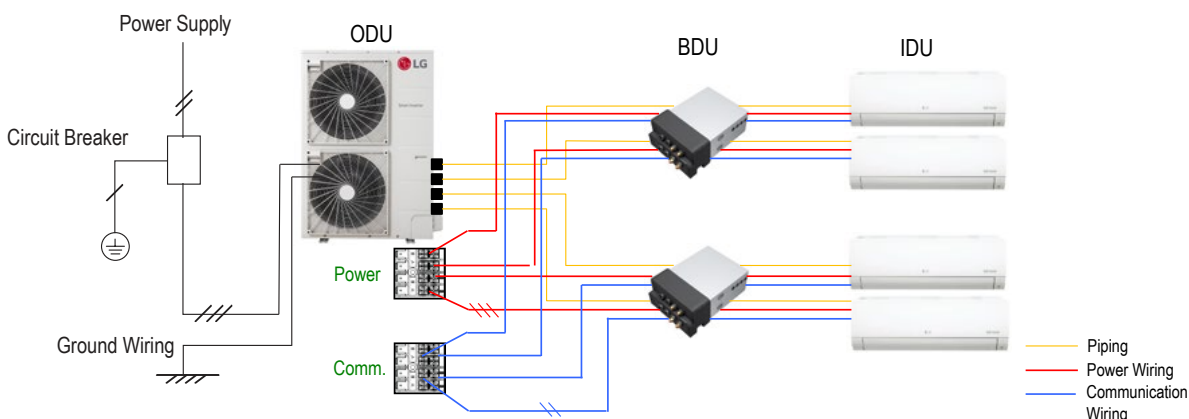


Figure 291: Example of a Multi F MAX with LGRED System General Power / Communications System Schematic.

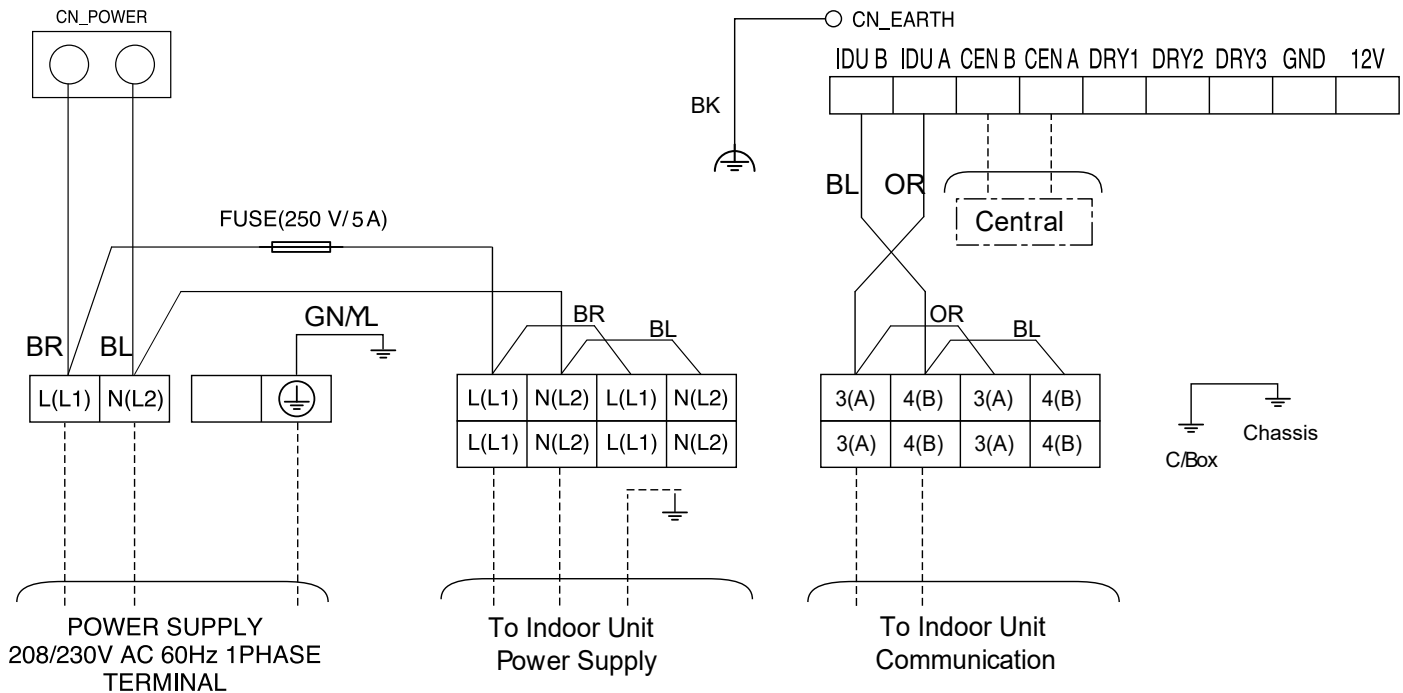


# ELECTRICAL CONNECTIONS

Multi F Systems

MULTI F  
MULTI F MAX

Figure 292: Multi F KUMXB181A and KUMXB241A System Power Wiring and Communications Cable.



Connect the power wiring and communication wiring according to the number of indoor units installed.

## NOTICE

KUMXB181A can support no more than two indoor units; KUMXB241A can support two or three indoor units. Ensure the communication wiring and power wiring from the outdoor unit to the indoor units is installed correctly for the system and the chosen application.

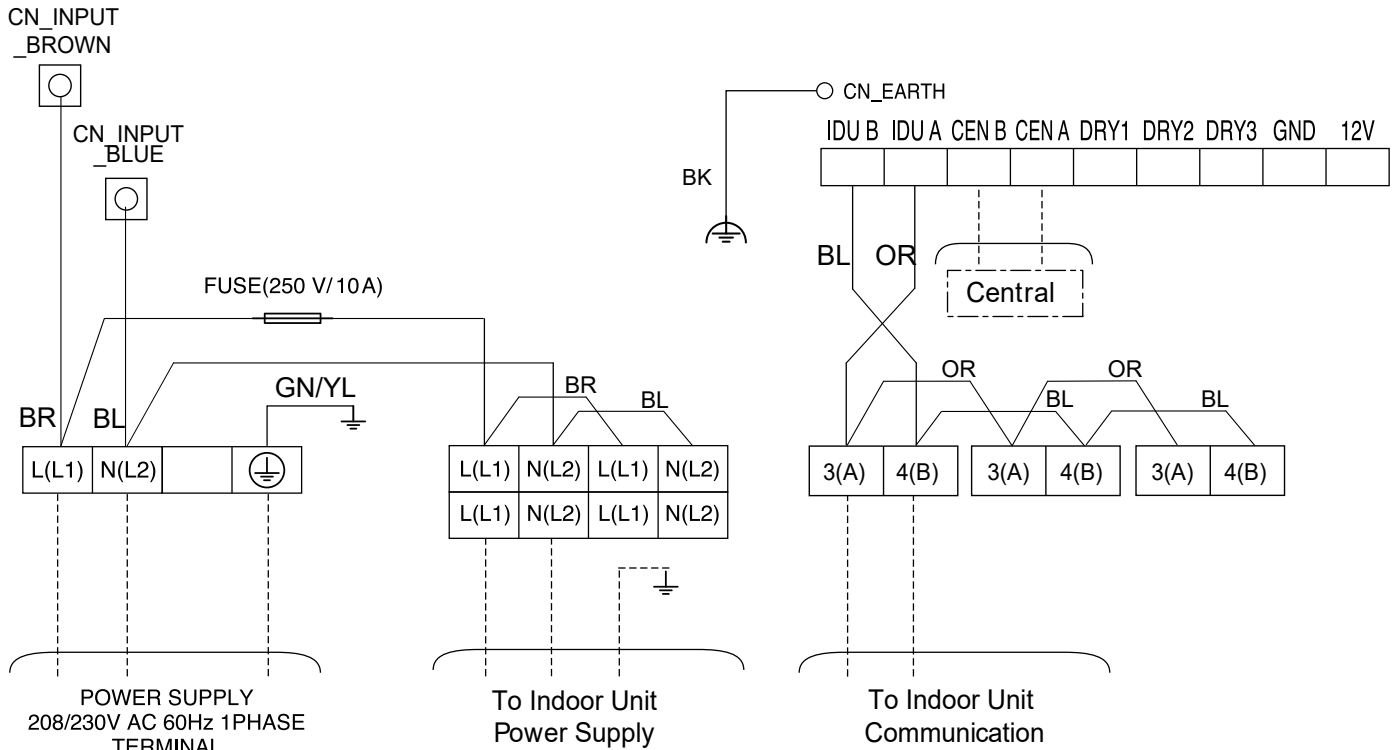
## WARNING

- All field-supplied wiring, components, and materials must comply with all applicable national, state, and local codes and requirements. Improper wiring will result in fire, electric shock, causing physical injury or death.
- Ground wiring is required to prevent accidental electrical shock during current leakage, communication problems from electrical noise, and motor current leakage. ⚠ Do not connect the ground line to the pipes. There is a risk of fire, electric shock, explosion, resulting in physical injury or death.
- Install a main shutoff switch or circuit breaker that interrupts all power sources simultaneously. There is a risk of fire, electric shock, explosion, resulting in physical injury or death.

## NOTICE

- Terminal block labels, appearances, and location will vary depending on outdoor unit model.
- Maintain polarity throughout the communication network. The system will malfunction if not properly wired.
- All field-supplied wiring, components, sizes, and materials must comply with all applicable national, state, and local codes and requirements. Failure to install proper electrical components can result in property damage and equipment malfunction.
- Ground wiring is required to prevent communication problems from electrical noise, and motor current leakage. Failure to provide proper ground wiring can result in property damage and equipment malfunction.
- Install a main shutoff switch or circuit breaker that interrupts all power sources simultaneously. Failure to install proper electric components will result in property damage and equipment malfunction.

Figure 293: Multi F KUMXB301A and KUMXB361A System Power Wiring and Communications Wiring.



Connect the power wiring and communication wiring according to the number of indoor units installed.

**NOTICE**

KUMXB301A and KUMXB361A can support up to four indoor units. Ensure the communication wiring and power wiring from the outdoor unit to the indoor units is installed correctly for the system and the chosen application.

**WARNING**

- All field-supplied wiring, components, and materials must comply with all applicable national, state, and local codes and requirements. Improper wiring will result in fire, electric shock, causing physical injury or death.
- Ground wiring is required to prevent accidental electrical shock during current leakage, communication problems from electrical noise, and motor current leakage. ⚠ Do not connect the ground line to the pipes. There is a risk of fire, electric shock, explosion, resulting in physical injury or death.
- Install a main shutoff switch or circuit breaker that interrupts all power sources simultaneously. There is a risk of fire, electric shock, explosion, resulting in physical injury or death.

**NOTICE**

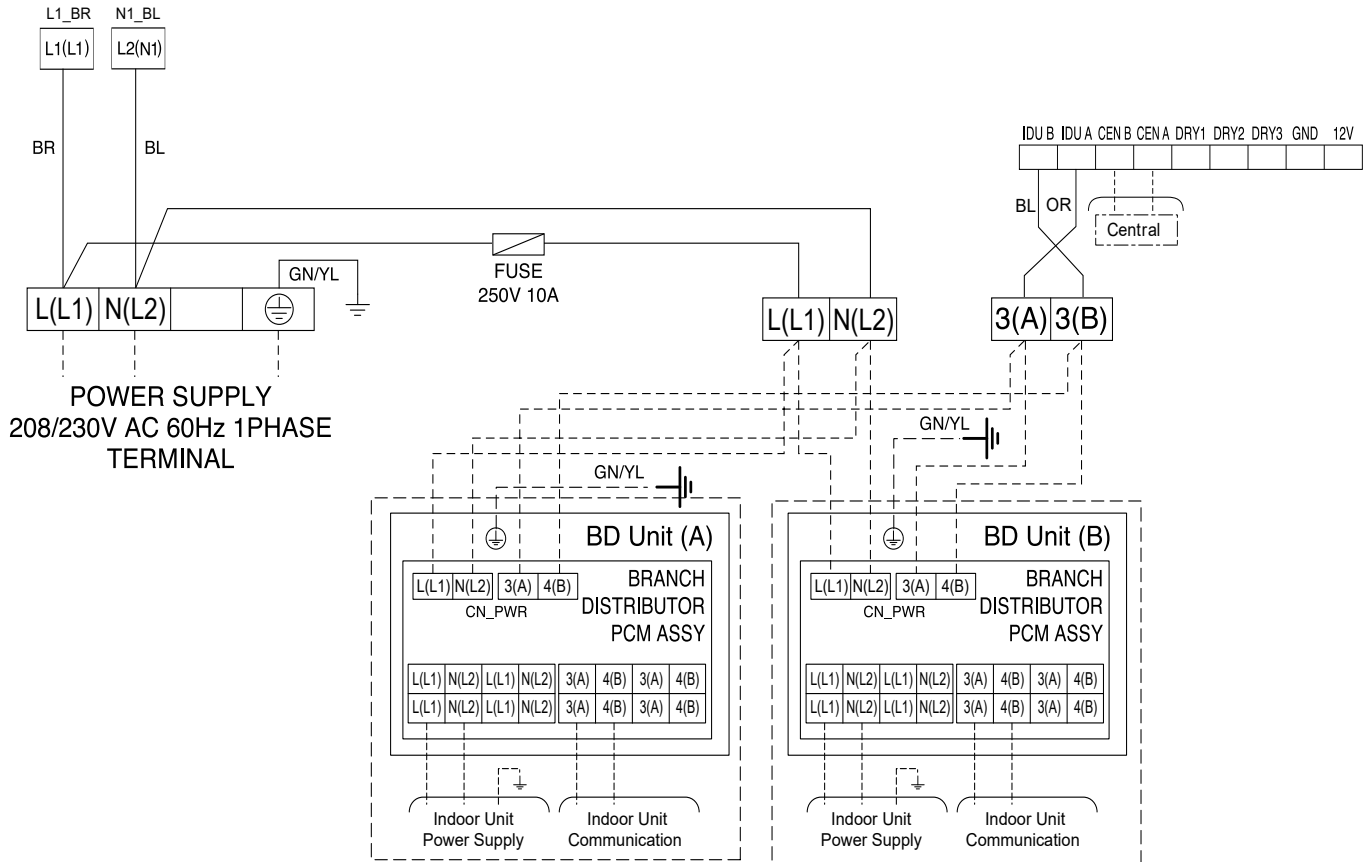
- Terminal block labels, appearances, and location will vary depending on outdoor unit model.
- Maintain polarity throughout the communication network. The system will malfunction if not properly wired.
- All field-supplied wiring, components, sizes, and materials must comply with all applicable national, state, and local codes and requirements. Failure to install proper electrical components can result in property damage and equipment malfunction.
- Ground wiring is required to prevent communication problems from electrical noise, and motor current leakage. Failure to provide proper ground wiring can result in property damage and equipment malfunction.
- Install a main shutoff switch or circuit breaker that interrupts all power sources simultaneously. Failure to install proper electric components will result in property damage and equipment malfunction.

# ELECTRICAL CONNECTIONS

Multi F MAX Systems

MULTI F  
MULTI F MAX

Figure 294: Multi F MAX KUMXB481A, KUMXB541A, and KUMXB601A System Power Wiring and Communications Wiring.



Connect power wiring and communications wiring according to the number of indoor units installed.

## NOTICE

KUMXB481A, KUMXB541A, and KUMXB601A can support up to two branch distribution units and up to eight indoor units. Ensure the communication wiring and power wiring from the outdoor unit to the indoor units is installed correctly for the system and the chosen application.

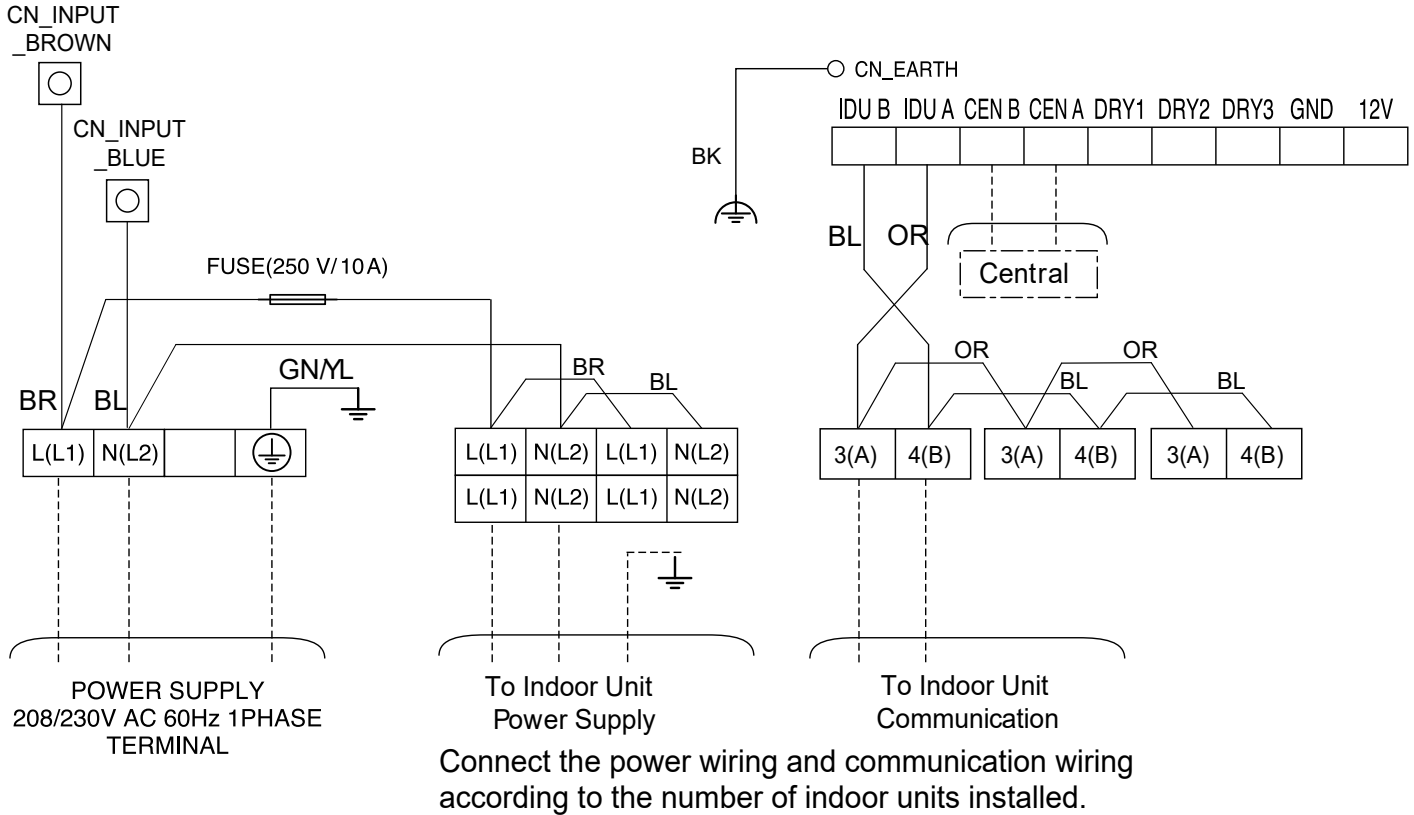
## ⚠ WARNING

- All field-supplied wiring, components, and materials must comply with all applicable national, state, and local codes and requirements. Improper wiring will result in fire, electric shock, causing physical injury or death.
- Ground wiring is required to prevent accidental electrical shock during current leakage, communication problems from electrical noise, and motor current leakage. ⚡ Do not connect the ground line to the pipes. There is a risk of fire, electric shock, explosion, resulting in physical injury or death.
- Install a main shutoff switch or circuit breaker that interrupts all power sources simultaneously. There is a risk of fire, electric shock, explosion, resulting in physical injury or death.

## NOTICE

- Terminal block labels, appearances, and location will vary depending on outdoor unit model.
- Maintain polarity throughout the communication network. The system will malfunction if not properly wired.
- All field-supplied wiring, components, sizes, and materials must comply with all applicable national, state, and local codes and requirements. Failure to install proper electrical components can result in property damage and equipment malfunction.
- Ground wiring is required to prevent communication problems from electrical noise, and motor current leakage. Failure to provide proper ground wiring can result in property damage and equipment malfunction.
- Install a main shutoff switch or circuit breaker that interrupts all power sources simultaneously. Failure to install proper electric components will result in property damage and equipment malfunction.

Figure 295: Multi F with LGRED KUMXA181A, KUMXA241A, and KUMXA301A System Power Wiring and Communications Cable.



**NOTICE**

KUMXA181A can support no more than two indoor units; KUMXA241A can support two or three indoor units; KUMXA301A can support two, three, or four indoor units. Ensure the communication wiring and power wiring from the outdoor unit to the indoor units is installed correctly for the system and the chosen application.

**⚠ WARNING**

- All field-supplied wiring, components, and materials must comply with all applicable national, state, and local codes and requirements. Improper wiring will result in fire, electric shock, causing physical injury or death.
- Ground wiring is required to prevent accidental electrical shock during current leakage, communication problems from electrical noise, and motor current leakage. ⚡ Do not connect the ground line to the pipes. There is a risk of fire, electric shock, explosion, resulting in physical injury or death.
- Install a main shutoff switch or circuit breaker that interrupts all power sources simultaneously. There is a risk of fire, electric shock, explosion, resulting in physical injury or death.

**NOTICE**

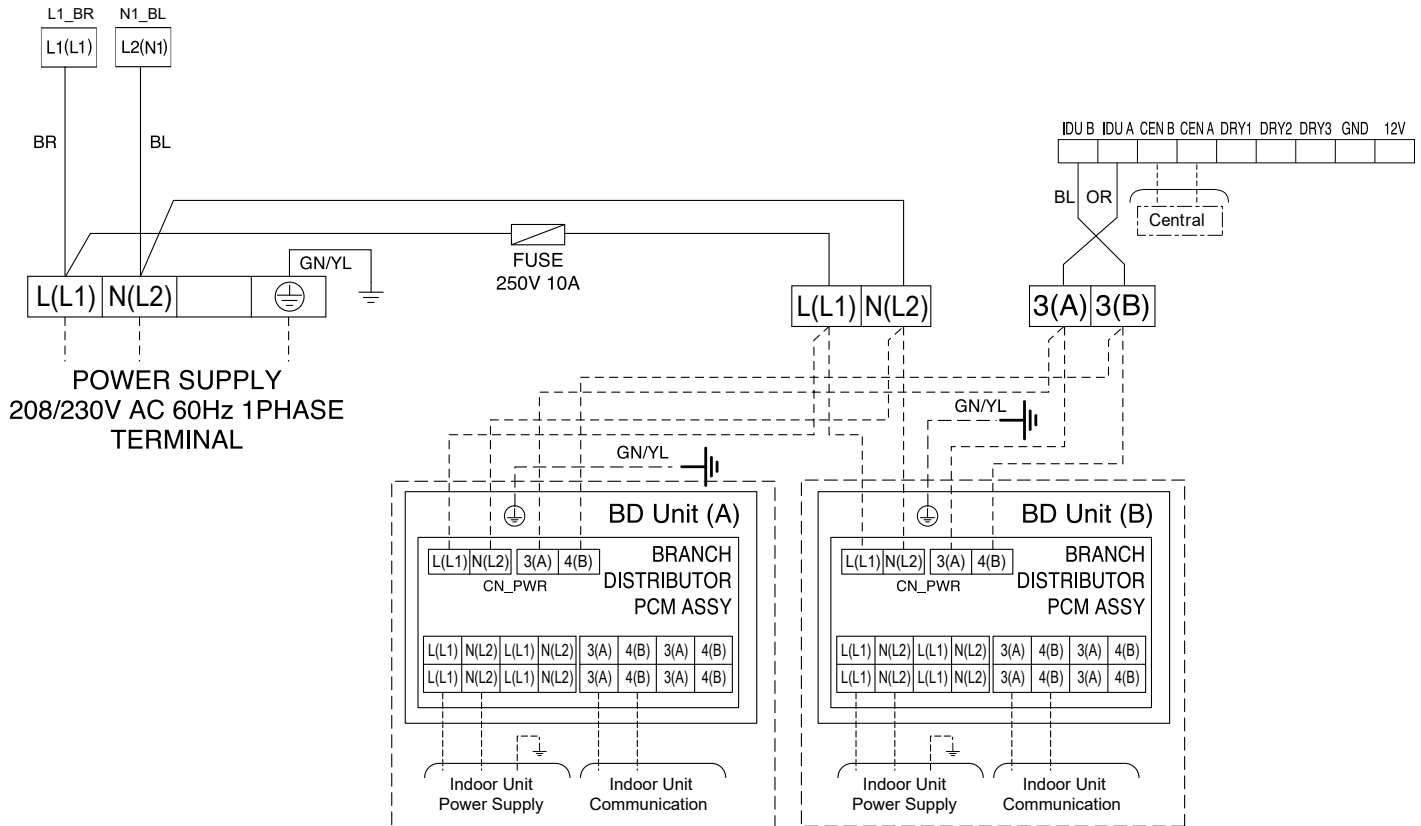
- Terminal block labels, appearances, and location will vary depending on outdoor unit model.
- Maintain polarity throughout the communication network. The system will malfunction if not properly wired.
- All field-supplied wiring, components, sizes, and materials must comply with all applicable national, state, and local codes and requirements. Failure to install proper electrical components can result in property damage and equipment malfunction.
- Ground wiring is required to prevent communication problems from electrical noise, and motor current leakage. Failure to provide proper ground wiring can result in property damage and equipment malfunction.
- Install a main shutoff switch or circuit breaker that interrupts all power sources simultaneously. Failure to install proper electric components will result in property damage and equipment malfunction.

# ELECTRICAL CONNECTIONS

## Multi F MAX with LGRED Systems

MULTI F  
MULTI F MAX

Figure 296: Multi F MAX with LGRED KUMXA361A, KUMXA421A, and KUMXA481A System Power Wiring and Communications Cable.



Connect power wiring and communications wiring according to the number of indoor units installed.

### NOTICE

KUMXA361A can support up to two branch distribution units and up to five indoor units. KUMXA421A can support up to two branch distribution units and up to six indoor units. KUMXA481A can support up to two branch distribution units and up to eight indoor units. Ensure the communication wiring and power wiring from the outdoor unit to the indoor units is installed correctly for the system and the chosen application.

### ⚠ WARNING

- All field-supplied wiring, components, and materials must comply with all applicable national, state, and local codes and requirements. Improper wiring will result in fire, electric shock, causing physical injury or death.
- Ground wiring is required to prevent accidental electrical shock during current leakage, communication problems from electrical noise, and motor current leakage. ⓧ Do not connect the ground line to the pipes. There is a risk of fire, electric shock, explosion, resulting in physical injury or death.
- Install a main shutoff switch or circuit breaker that interrupts all power sources simultaneously. There is a risk of fire, electric shock, explosion, resulting in physical injury or death.

### NOTICE

- Terminal block labels, appearances, and location will vary depending on outdoor unit model.
- Maintain polarity throughout the communication network. The system will malfunction if not properly wired.
- All field-supplied wiring, components, sizes, and materials must comply with all applicable national, state, and local codes and requirements. Failure to install proper electrical components can result in property damage and equipment malfunction.
- Ground wiring is required to prevent communication problems from electrical noise, and motor current leakage. Failure to provide proper ground wiring can result in property damage and equipment malfunction.
- Install a main shutoff switch or circuit breaker that interrupts all power sources simultaneously. Failure to install proper electric components will result in property damage and equipment malfunction.

### From Indoor Units to Remote Controllers

- Communication cable from indoor unit to remote controller(s) is to be field provided or LG provided 22 AWG, 3-conductor, twisted, stranded, unshielded. Wiring must comply with all applicable local and national codes.
- If using the LG Controller / Extension cable and the length needs to be further extended, the LG Extension Kit (sold separately) must be used. A maximum of four (4) kits (up to 165 feet) can be used.
- Remote controllers have hardwired connections: SIG - 12V - GND (Comm.) terminals.
- Indoor unit controller connections depend on type of indoor unit being installed. Some indoor units use terminal block connections; other indoor units use Molex connections. See diagrams below for the two options. Refer to the wiring diagram schematic found in the indoor unit itself, or to the indoor unit wiring diagrams in the Engineering Manuals for more information.
- ⚠ NEVER splice, cut, or extend LG provided cable with field provided cable. Always include enough cable to cover distance between the indoor unit and the remote controller.
- Set the indoor unit operating parameters using DIP switches, or by setting up the remote controller. Refer to the indoor unit installation manuals for more details.

Figure 297: One Example of Indoor Unit to Zone Controller Connection.

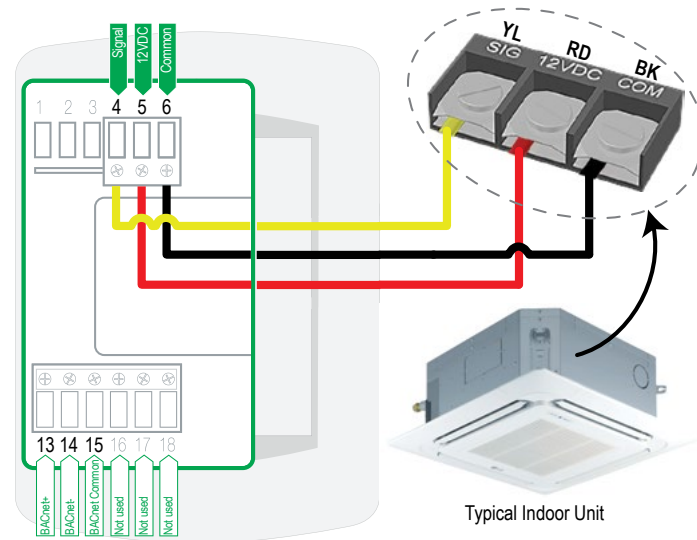
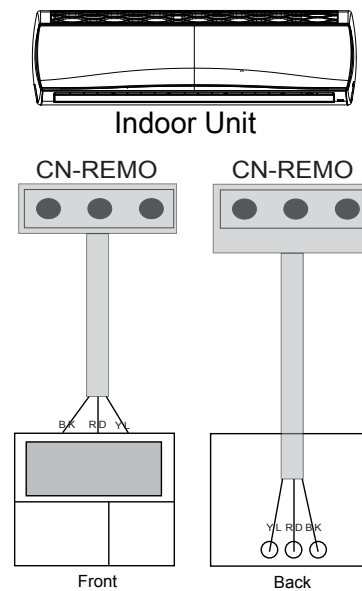


Figure 298: Another Example of Indoor Unit to Zone Controller Connection.



### NOTICE

Cable connected to Zone Controller is the factory default connection.

# ELECTRICAL CONNECTIONS

## Indoor Unit Group Control

MULTI F  
MULTI F MAX

### Between Multiple Indoor Units Operating as a Group (Group Control)

#### If any indoor units were specified to operate in unison:

- Before running the field provided or LG provided cable, decide which indoor unit will be the “Main.” The other indoor units in that group will be designated as “Sub(s).” The zone controller will be connected to the “Main.”
- Set the pertinent DIP switch at each indoor unit to identify the Main and Sub(s). On wall mounted indoor unit models, set the assignment using the handheld remote controller.
- Use a daisy chain configuration and connect all of the group’s indoor units together starting at the “Main” unit.
- ⚠ NEVER splice, cut, or extend LG provided cable with field provided cable. Always include enough cable to cover distance between all components.

#### For indoor units with hardwired connections SIG - 12V - GND (Comm.) terminals:

- From the controller to the main indoor unit, use field provided or LG provided 22 AWG, 3-conductor, twisted, stranded, unshielded. All wiring must comply with all applicable local / national codes.
- From the main indoor unit to the sub indoor unit(s), daisy chain using field provided or LG provided 22 AWG, 3-conductor, twisted, stranded, unshielded. All wiring must comply with all applicable local / national codes.
- ⚠ Do not attach wire to 12VDC terminal to the sub indoor units. All wiring must comply with all applicable local and national codes.
- ⚠ NEVER splice, cut, or extend LG provided cable with field provided cable. Always include enough cable to cover distance between all components.

#### For indoor units with CN-REMO connections:

Use one (or multiple) Group Control Kit(s) (sold separately) containing extension and Y-splitter cables. Use one (1) group control cable kit for each indoor unit in the group except for the last indoor unit. ⚠ NEVER splice, cut, or extend cable length with field provided cable.

#### NOTICE

- Cable connected to zone controller is the factory default connection.
- Indoor unit connections depend on indoor unit type.

#### General Specifications

- Wired remote controllers can be connected to all indoor unit types.
- Wireless controllers can be used in conjunction with wired remote controllers.
- A dry contact unit can be connected with a central controller simultaneously.
  - The main indoor unit is recognized by the dry contact unit and the central controller.
  - Group Control only available for indoor units manufactured after February 2009.
  - The central controller can control indoor units after setting the address of the main indoor unit only.
  - Sub indoor unit cannot be individually controlled by central controller.
  - Sub indoor unit will operate like main indoor unit.
- If an error occurs with the indoor unit, the error will be displayed on the wired remote controller.
- The following functions are available with group control:
  - Selection of operation options (operation/mode/set temperature)
  - Control of air flow rate (High/Medium/Low)

Figure 299: Example of Indoor Unit Group to Zone Controller Connections (Sig-12V-GND [Comm.] Terminal).

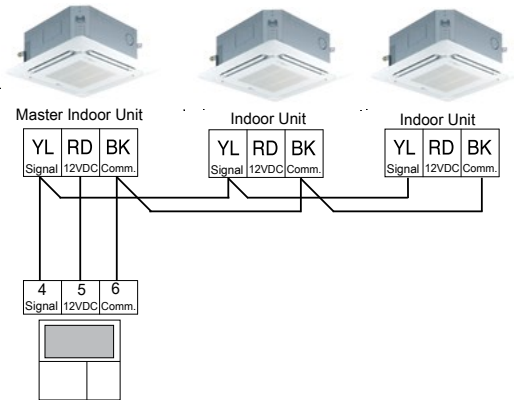


Figure 300: Example of Indoor Unit Group to Zone Controller Connections (CN-REMO).

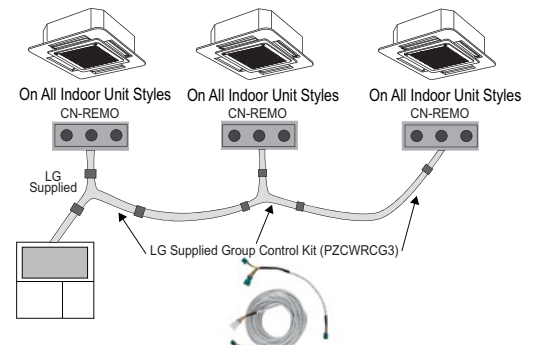
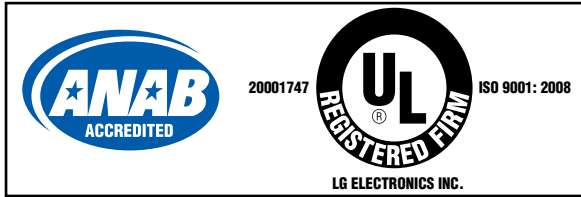


Table 144: Accessories for Some Group Control Applications.

Accessory	Model Number	Image
Wired Remote Group Control Cable Assembly - For connecting multiple indoor units to a control group	PZCWRCG3	
Wired Remote/Wired Remote Extension Cable - For extending the distance between indoor units or remote controllers in a control group	PZCWRC1	

*Inverter*



LG Electronics, U.S.A., Inc.  
Air Conditioning Technologies  
4300 North Point Parkway  
Alpharetta, Georgia 30022  
[www.lghvac.com](http://www.lghvac.com)

EM\_MultiF\_R32\_IDU\_1\_26  
Supersedes: EM\_MultiF\_R32\_IDU\_07\_25  
EM\_MultiF\_R32\_IDU\_06\_25  
EM\_MultiF\_R32\_IDU\_03\_25