

Job Name/Location:

Tag No.:

Date:

For:	File	Resubmit
	Approval	Other_____

PO No.:

Architect: \_\_\_\_\_ GC: \_\_\_\_\_

Engr: \_\_\_\_\_ Mech: \_\_\_\_\_

Rep: \_\_\_\_\_  
(Company) (Project Manager)

**KSSLB301A**  
R32 Single Zone Multi-Position Air Handling Unit  
Outdoor Unit (ODU) - KUSXB301A, Indoor Unit (IDU) - KNSLB301A



**Performance:**

**Cooling:**

Cooling Capacity (Min~Rated~Max, Btu/h)	12,000 ~ 27,000 ~ 32,500
SEER2	17.00
EER2	11.70

SEER - Seasonal Energy Efficiency Ratio EER - Energy Efficiency Ratio

**Heating:**

Heating Capacity (Min~Rated~Max, Btu/h)	13,600 ~ 34,000 ~ 36,600
HSPF2	9.60
Max. Heating @ Indoor 70°F DB (Btu/h)	
Outdoor 17°F WB	31,500
Outdoor 5°F WB	30,000
Outdoor -4°F WB	26,000

HSPF - Heating Seasonal Performance Factor Heating Nominal Test Conditions:  
Cooling Nominal Test Conditions: Indoor: 70°F DB / 60°F WB  
Indoor: 80°F DB / 67°F WB Outdoor: 47°F DB / 43°F WB  
Outdoor: 95°F DB / 75°F WB

**Electrical:**

Power Supply (V/Hz/Ø)	208-230/60/1
MOP (A)	30
MCA (A)	19.1
Cooling / Heating Rated Amps (A)	10.1 / 11.8
Compressor (A)	22
Fan Motor (IDU + ODU) (A)	3.4 + 1.6
Cooling Power Input (Min~Rated~Max, kW)	0.72 ~ 2.31 ~ 2.58
Heating Power Input (Min~Rated~Max, kW)	0.80 ~ 2.69 ~ 3.50
Locked Rotor Amps (A)	22

MOP - Maximum Overcurrent Protection MCA - Minimum Circuit Ampacity

**Piping:**

Installed Liquid Pipe (in., O.D.)	3/8
Installed Vapor Pipe (in., O.D.)	5/8
IDU Liquid Connection (in., O.D.)	3/8
IDU Vapor Connection (in., O.D.)	5/8
Additional Refrigerant (oz./ft.)	0.38
Min. / Max. Pipe Length (ft.) <sup>2</sup>	16.4 / 164
Piping Length (no add'l refig., ft.)	24.6
Max. Elevation (ft.)	98.4

**Controls Features:**

- Inverter (Variable Speed Compressor)
- R32 Leak Detection Sensor
- Child Lock
- Auto Operation
- Hot Start
- Self Diagnosis
- Auto Restart
- Soft Dry Operation
- Sleep Mode
- Auto Changeover
- Timer (on/off/weekly)
- Two Thermistor Control
- Optional Wi-Fi Control
- ESP Control
- ECM fan provides constant airflow regardless of permitted ESP

**Standard Features:**

- Access Panel for Field Supplied Air Filter - 16 x 20 x 1

**Optional Accessories:**

- Auxiliary Heater Kit - PRARH1
- Downflow Conversion Kit - PNDFA0
- Wi-Fi Module - PWFMD200
- Electric Heat Kits - ANEHxx3Cx<sup>3</sup>
- Single Port Shutoff Valve - PRHPZ010A
- ODU Wind Baffle - ZLABGP04B
- ODU Base Pan Heater - PQSH1200

**Controller Options:**

- Wireless Remote Controller<sup>4</sup>
- Dry Contacts
- MultiSITE™ CRC Controllers
- AC Smart 5 Central Controller
- Simple Remote Controller
- LonWorks® Gateway
- Standard III Remote Controllers
- MultiSITE Comm. Mgr.
- Remote Temperature Button Sensor
- ACP 5 BACnet™ Gateway

For a complete list of available accessories, contact your LG representative.

For continual product development, LG reserves the right to change specifications without notice.

© LG Electronics U.S.A., Inc., Englewood Cliffs, NJ. All rights reserved. "LG Life's Good" is a registered trademark of LG Corp. /www.lghvac.com

**Operating Range:**

**Outdoor Unit:**

Cooling (°F DB)	5 ~ 118
Heating (°F WB)	-4 ~ +64

**Indoor Unit:**

Cooling (°F WB)	57 ~ 77
Heating (°F DB)	59 ~ 81

**System Data:**

Refrigerant Type	R32
Refrigerant Control	EEV
Refrigerant Charge (oz)	67
ODU Sound Pressure (Cooling / Heating) (±1 dB[A]) <sup>5</sup>	52 / 54
IDU Sound Pressure (H/M/L) (±1 dB[A]) <sup>5</sup>	40 / 37 / 35
ODU Net / Shipping Weight (lbs.)	141.1 / 159.4
IDU Net / Shipping Weight (lbs.)	141 / 147
Heat Exchanger Coating	GoldFin™

**Fan:**

ODU Type	Propeller
IDU Type	Sirocco
Fan Speeds (Fan/Cool/Heat)	3 / 3 / 3
Fan Quantity (ODU + IDU)	1 + 1
Motor/Drive	Brushless Digitally Controlled/Direct
Maximum ODU Air Volume (CFM)	2,048
IDU Air Flow (CFM Max. H/M/L)	875 / 750 / 630
Minimum~Maximum ESP (in wg)	0.1 ~ 1.0
Dehumidification (pts./hr.)	5.6

**Notes:**

- Acceptable operating voltage: 187V-253V.
- Piping lengths are equivalent.
- Refer to the Engineering Manual for available auxiliary heater capacities.
- Requires an LG wall controller because Multi-Position AHU do not have an infrared receiver.
- Sound Pressure levels are tested in an anechoic chamber under ISO Standard 3745.
- All power supply wiring to the outdoor unit is field supplied, solid or stranded. The power wiring and the communication wiring from the outdoor unit to the indoor unit is field supplied and must be stranded, shielded or unshielded (if shielded, it must be grounded to the chassis of the outdoor unit only). All wiring must comply with applicable local and national codes.
  - Power Supply Wiring to ODU: (No. x AWG): 3 x 12 for 12k, 18k, and 24k; 3 x 10 for 30k, 36k, 42k, 48k and 60k.
  - Power Wiring and Communication Wiring from Outdoor Unit to Indoor Unit: (No. x AWG) 3 x 14 / 2 x 18.
- See Engineering Manual for sensible and latent capacities.
- Power wiring cable size must comply with the applicable local and national code.
- The indoor unit comes with a dry helium charge.
- This data is rated 0 ft. above sea level, with 24.6 ft. of refrigerant line and a 0 ft. level difference between outdoor and indoor units.
- Must follow installation instructions in the applicable LG installation manual.
- If the optional low ambient wind baffle is used, one wind baffle is required for each ODU fan.

BACnet™ is a registered trademark of ASHRAE. LonWorks® is a trademark of Echelon Corporation.



Proper sizing and installation of equipment is critical to achieve optimal performance. Split system air conditioners and heat pumps (excluding ductless systems) must be matched with appropriate coil components to meet ENERGY STAR® criteria. Ask your contractor for details or visit [www.energystar.gov](http://www.energystar.gov). (ENERGY STAR and the ENERGY STAR mark are registered trademarks owned by the U.S. Environmental Protection Agency.)

SB\_SZ\_Multi\_Position\_AHU\_HighEff\_R32\_KSSLB301A\_2026\_03\_11\_112707

**KSSLB301A**  
R32 Single Zone Multi-Position Air Handling Unit  
Outdoor Unit (ODU) - KUSXB301A, Indoor Unit (IDU) - KNSLB301A



Tag No.: \_\_\_\_\_

Date: \_\_\_\_\_

PO No.: \_\_\_\_\_

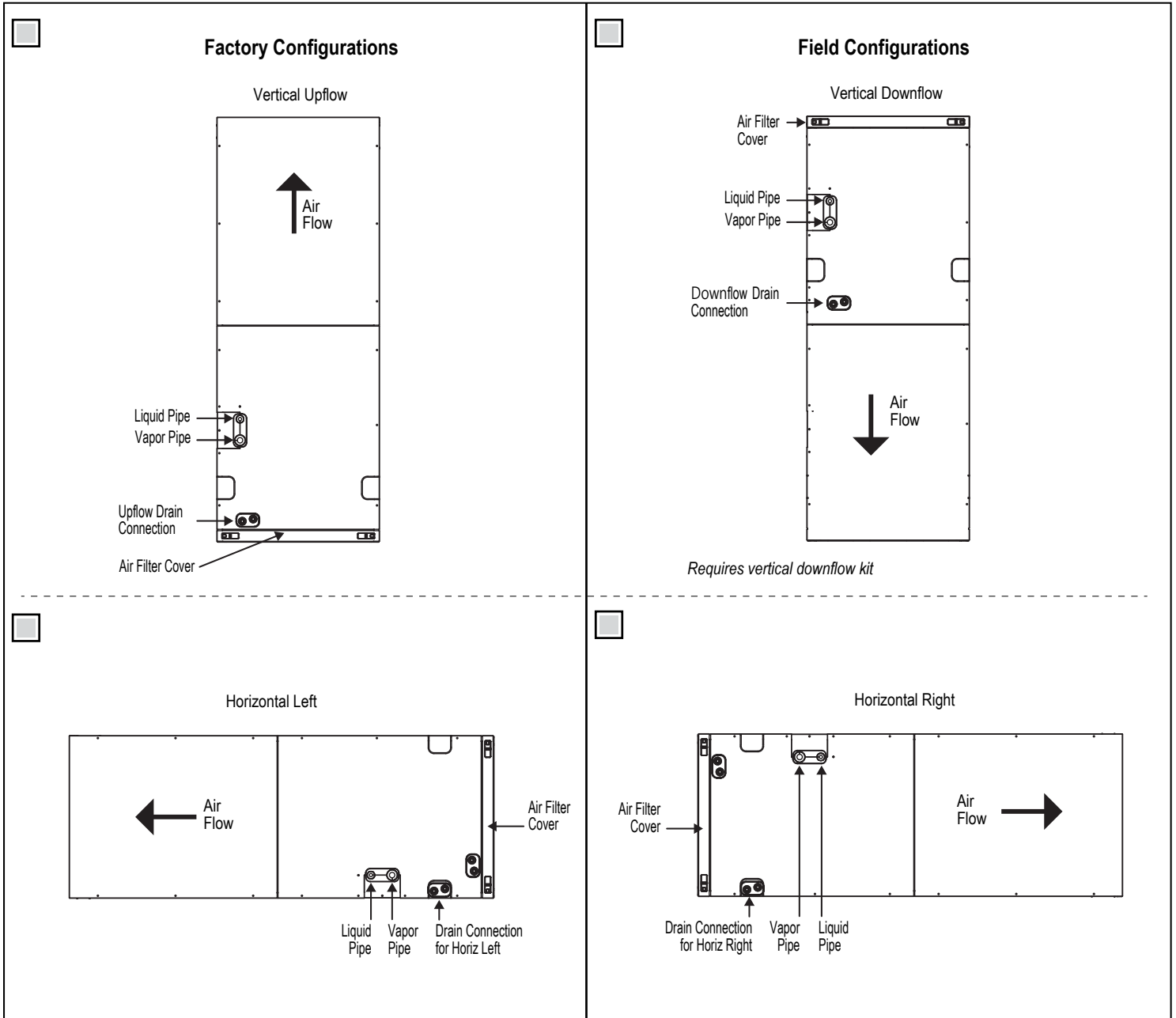

**KSSLB301A**  
**R32 Single Zone Multi-Position Air Handling Unit**  
 Outdoor Unit (ODU) - KUSXB301A, Indoor Unit (IDU) - KNSLB301A



Tag No.: \_\_\_\_\_

Date: \_\_\_\_\_

PO No.: \_\_\_\_\_

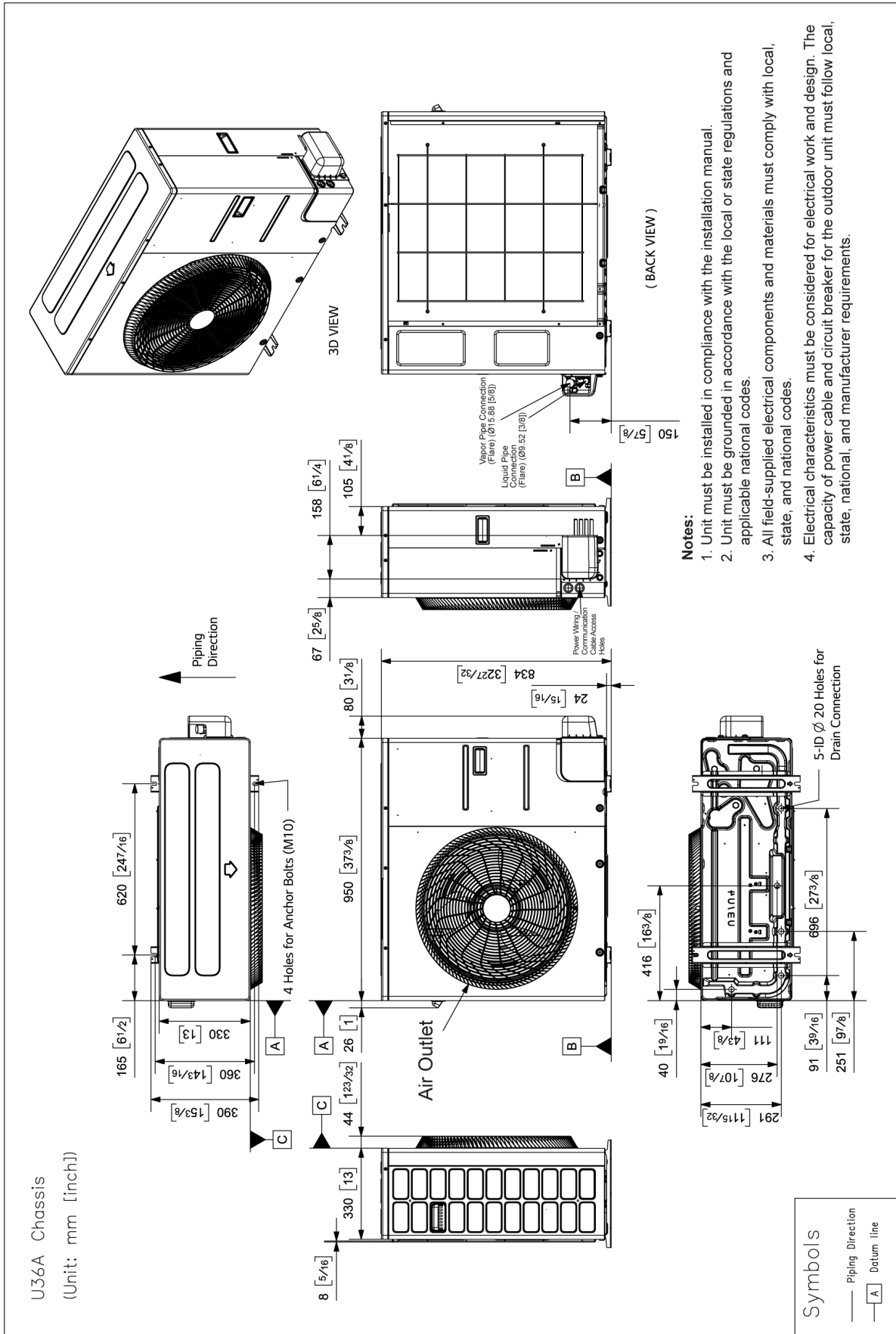

**KSSLB301A**  
**R32 Single Zone Multi-Position Air Handling Unit**  
 Outdoor Unit (ODU) - KUSXB301A, Indoor Unit (IDU) - KNSLB301A



Tag No.: \_\_\_\_\_

Date: \_\_\_\_\_

PO No.: \_\_\_\_\_

