

STEALTH®

STEALTH R454B PRE-CHARGED LINE SET

WITH DIYCOOL TECHNOLOGY

INSTALLATION MANUAL

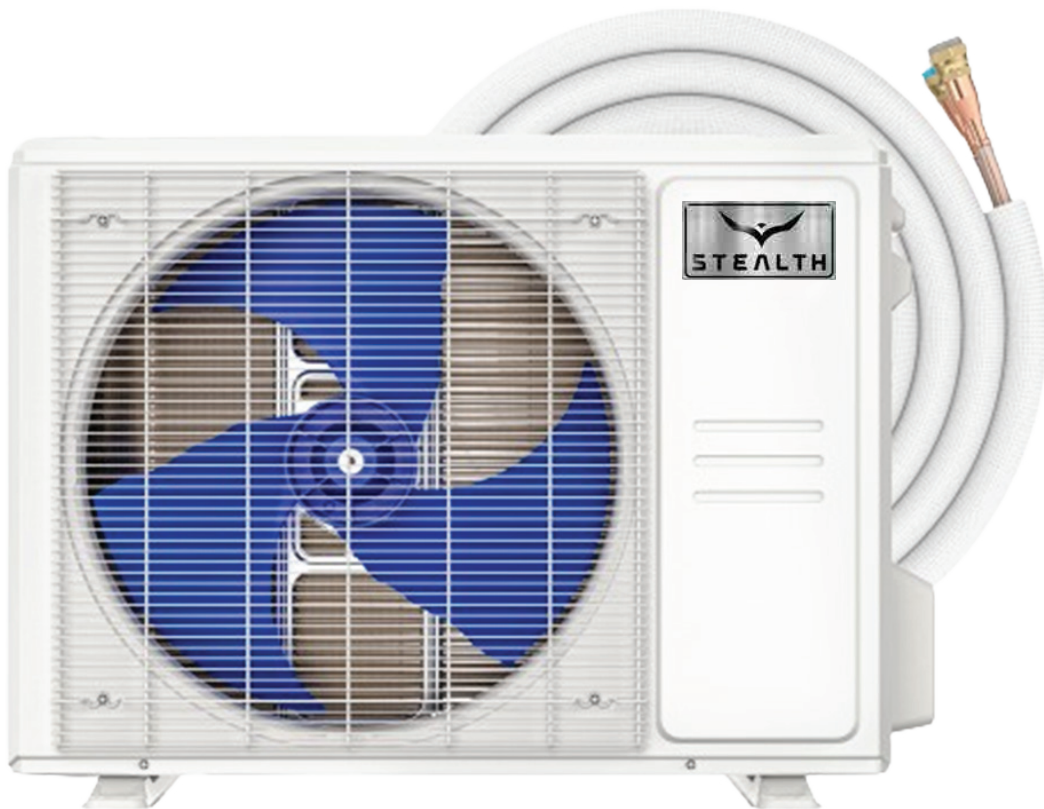

IMPORTANT NOTE:

Read this manual carefully before installing or operating your system. Please be sure to save this manual for future reference.

Version Date: 08-07-25

Table of Contents

Safety Precautions	2
Accessories	11
Preperation & Connecting Line Set to Indoor Unit	12
Connecting Line Set to Outdoor Unit	14
Wrapping & Insulating Line Set Connections	17
Electrical & Gas Leak Checks	18
Test Run	19

Safety Precautions

It is really important that you read Safety Precautions Before Operation and Installation. Incorrect installation due to ignoring instructions can cause serious damage or injury. The seriousness of potential damage or injuries is classified as either a WARNING or CAUTION.

Explanation of Symbols



WARNING

This symbol indicates the possibility of personnel injury or loss of life.



CAUTION

This symbol indicates the possibility of property damage or serious consequences.

⚠ ELECTRICAL WARNINGS

- Only use the specified wire. If the wire is damaged, it must be replaced by the manufacturer, its service agent or similarly qualified persons in order to avoid a hazard.
- The product must be properly grounded at the time of installation, or electric shock may occur.
- For all electrical work, follow all local and national wiring standards, regulations, and the Installation Manual. Connect cables tightly, and clamp them securely to prevent external forces from damaging the terminal. Improper electrical connections can overheat and cause fire, and may also cause shock. All electrical connections must be made according to the Electrical Connection Diagram located on the panels of the indoor and outdoor units.
- All wiring must be properly arranged to ensure that the control board cover can close properly. If the control board cover is not closed properly, it can lead to corrosion and cause the connection points on the terminal to heat up, catch fire, or cause electrical shock.
- Disconnection must be incorporated in the fixed wiring in accordance with the NEC, CEC or local codes.
- Do not share the electrical outlet with other appliances. Unit must be installed on dedicated electrical circuit.

WARNINGS FOR PRODUCT INSTALLATION

- Turn off the air conditioner and disconnect the power before performing any installation or repairs. Failure to do so can cause electric shock.
- Installation must be performed by an authorized dealer or specialist according to the installation instructions. Improper installation can cause water damage, electrical hazard or fire. Contact an authorized service technician for repair or maintenance.
- This appliance shall be installed in accordance with national wiring regulations. Only use the included accessories, parts, and specified parts for installation.
- Using non-standard parts can cause water leakage, electrical shock, fire, and can cause the unit to fail.
- Install the unit in a firm location that can support the unit's weight. If the chosen location cannot support the unit's weight, or the installation is not done properly, the unit may drop and cause serious injury and damage.
- Install drainage piping according to the instructions in this manual. Improper drainage may cause water damage to your home and property.
- For units that have an auxiliary electric heater, do not install the unit within 1 meter (3 feet) of any combustible materials.
- For the units that have a wireless network function, the USB device access, replacement, maintenance operations must be carried out by professional staff.
- Do not install the unit in a location that may be exposed to combustible gas leaks. If combustible gas accumulates around the unit, it may cause fire.
- Do not turn on the power until all work has been completed.
- When moving or relocating the air conditioner, consult experienced service technicians for disconnection and reinstallation of the unit.
- How to install the appliance to its support, please read the information for details in "indoor unit installation" and "outdoor unit installation" sections.

WARNINGS FOR CLEANING AND MAINTENANCE

- Turn off the device and disconnect the power before cleaning. Failure to do so can cause electrical shock.
- **Do not** clean the air conditioner with excessive amounts of water.
- **Do not** clean the air conditioner with combustible cleaning agents. Combustible cleaning agents can cause fire or deformation.

NOTE ABOUT FLUORINATED GASSES (NOT APPLICABLE TO THE UNIT USING R290 REFRIGERANT)

- This air-conditioning unit contains fluorinated greenhouse gasses. For specific information on the type of gas and the amount, please refer to the relevant label on the unit itself or the "Owner's Manual - Product Fiche" in the packaging of the outdoor unit.
- Installation, service, maintenance and repair of this unit must be performed by a certified technician.
- Product uninstallation and recycling must be performed by a certified technician.
- When the unit is checked for leaks, proper record-keeping of all checks is strongly recommended.

WARNINGS FOR R454B REFRIGERANT

For R454B refrigerant charge amount and minimum room area:

Refer to the Installation manual provided with the system purchased. The refrigerant charge amount will vary based on the type of system and the application of the installation.

1. Installation (where refrigerant pipes are allowed)

- Any person who is involved with working on or breaking into a refrigerant circuit should hold a current valid certificate from an industry-accredited assessment authority, which authorizes their competence to handle refrigerants safely in accordance with an industry recognized assessment specification.
- Maintenance and repair requiring the assistance of other skilled personnel shall be carried out under the supervision of the person competent in the use of flammable refrigerants.
- That the installation of pipe-work shall be kept to a minimum
- That pipe-work shall be protected from physical damage
- Where refrigerant pipes shall be compliance with national gas regulations
- That mechanical connections shall be accessible for maintenance purposes
- Be more careful that foreign matter (oil, water, etc) does not enter the piping. Also, when storing the piping, securely seal the opening by pinching, taping, etc.
- All working procedure that affects safety means shall only be carried out by competent persons.
- Appliance shall be stored in a well ventilated area where the room size corresponds to the room area as specified for operation.
- Joints shall be tested with detection equipment with a capability of 5 g/year of refrigerant or better, with the equipment in standstill and under operation or under a pressure of at least these standstill or operation conditions after installation. Detachable joints shall NOT be used in the indoor side of the unit (brazed, welded joint could be used).
- In cases that require mechanical ventilation, ventilation openings shall be kept clear of obstruction.
- LEAK DETECTION SYSTEM installed. Unit must be powered except for service. For the unit with refrigerant sensor, when the refrigerant sensor detects refrigerant leakage, the indoor unit will display an error code and emit a buzzing sound, the compressor of outdoor unit will immediately stop, and the indoor fan will start running. The service life of the refrigerant sensor is 15 years. When the refrigerant sensor malfunctions, the indoor unit will display the error code "FHCC". The refrigerant sensor can not be repaired and can only be replaced by the manufacturer. It shall only be replaced with the sensor specified by the manufacturer.

2. When a FLAMMABLE REFRIGERANT is used, the requirements for installation space of appliance and/or ventilation requirements are determined according to

- the mass charge amount (M) used in the app
- the installation location
- the type of ventilation of the location or of the app
- piping material, pipe routing, and installation shall include protection from physical damage in operation and service, and be in compliance with national and local codes and standards, such as ASHRAE 15, IAPMO Uniform Mechanical Code, ICC International Mechanical Code, or CSA B52. All field joints shall be accessible for inspection prior to being covered or enclosed.
- that protection devices, piping, and fittings shall be protected as far as possible against adverse environmental effects, for example, the danger of water collecting and freezing in relief pipes or the accumulation of dirt and debris;
- that piping in refrigeration systems shall be so designed and installed to minimize the likelihood of hydraulic shock damaging the system;
- that steel pipes and components shall be protected against corrosion by a rustproof coating before applying any insulation;
- that precautions shall be taken to avoid excessive vibration or pressure
- the minimum floor area of the room shall be mentioned in the form of a table or a single figure without reference to a formula;
- after completion of field piping for split systems, the field pipework shall be pressure tested with an inert gas and then vacuum tested prior to refrigerant charging, according to the following requirements:

- a. The minimum test pressure for the low side of the system shall be the low design pressure and the minimum test pressure for the high side of the system shall be the high side design pressure, unless the high side of the system can not be isolated from the low side of the system in which case the entire system shall be pressure tested to the low side design pressure.
 - b. The test pressure after removal of pressure source shall be maintained least 1 h with no decrease of pressure indicated by the test gauge, with test gauge resolution not exceeding 5% of the test pressure.
 - c. During the evacuation test, after achieving a vacuum level specified manual or less, the refrigeration system shall be isolated from the vacuum pump and the pressure shall not rise above 1500 microns within 10 min. The vacuum pressure level shall be specified in the manual, and shall be the lessor of 500 microns or the value required for compliance with national and local codes and standards, which may vary between residential, commercial, and industrial buildings.
- field-made refrigerant joints indoors shall be tightness tested according following requirements: The test method shall have a sensitivity of 5 grams per year of refrigerant or better under a pressure of at least 0.25 times the maximum allowable pressure. No leak shall be detected.

3 . Qualification of workers

Any maintenance, service and repair operations must be required qualification of the working personnel. Every working procedure that affects safety means shall only be carried out by competent persons that joined the training and achieved competence should be documented by a certificate. The training of these procedures is carried out by national training organizations or manufacturers that are accredited to teach the relevant national competency standards that may be set in legislation. All training shall follow the ANNEX HH requirements of UL 60335-2-40 4th Edition.

Examples for such working procedures are:

- breaking into the refrigerating circuit
- opening of sealed components
- opening of ventilated enclosures

4. Checks to the area

Prior to beginning work on systems containing flammable refrigerants, safety checks are necessary to ensure that the risk of ignition is minimised. For repair to the refrigerating system, the following precautions shall be complied with prior to conducting work on the system.

5. Work procedure

Works shall be undertaken under a controlled procedure so as to minimise the risk of a flammable gas or vapour being present while the work is being performed.

6. General work area

All maintenance staff and others working in the local area shall be instructed on the nature of work being carried out. work in confined spaces shall be avoided.

7. Checking for presence of refrigerant

The area shall be checked with an appropriate refrigerant detector prior to and during work, to ensure the technician is aware of potentially flammable atmospheres. Ensure that the leak detection equipment being used is suitable for use with flammable refrigerants, i.e. no sparking, adequately sealed or intrinsically safe.

8. Presence of fire extinguisher

If any hot work is to be conducted on the refrigeration equipment or any associated parts, appropriate fire extinguishing equipment shall be available to hand. Have a dry power or CO2 fire extinguisher adjacent to the charging area.

9. No ignition sources

No person carrying out work in relation to a REFRIGERATING SYSTEM which involves exposing any pipe work shall use any sources of ignition in such a manner that it may lead to the risk of fire or explosion. All possible ignition sources, including cigarette smoking, should be kept sufficiently far away from the site of installation, repairing, removing and disposal, during which refrigerant can possibly be released to the surrounding space. Prior to work taking place, the area around the equipment is to be surveyed to make sure that there are no flammable hazards or ignition risks. "No Smoking" signs shall be displayed.

10. Ventilated area

Ensure that the area is in the open or that it is adequately ventilated before breaking into the system or conducting any hot work. A degree of ventilation shall continue during the period that the work is carried out. The ventilation should safely disperse any released refrigerant and preferably expel it externally into the atmosphere.

11. Checks to the refrigeration equipment

Where electrical components are being changed, they shall be fit for the purpose and to the correct specification. At all times the manufacturer's maintenance and service guidelines shall be followed. If in doubt consult the manufacturer's technical department for assistance. The following checks shall be applied to installations using FLAMMABLE REFRIGERANTS:

- the actual refrigerant charge is in accordance with the room size within which the refrigerant containing parts are installed;
- the ventilation machinery and outlets are operating adequately and are not obstructed;
- if an indirect refrigerating circuit is being used, the secondary circuits shall be checked for the presence of refrigerant;
- marking to the equipment continues to be visible and legible, marking and signs that are illegible shall be corrected;
- refrigeration pipe or components are installed in a position where they are unlikely to be exposed to any substance which may corrode refrigerant containing components, unless the components are constructed of materials which are inherently resistant to being corroded or are suitably protected against being so corroded.

12. Checks to electrical devices

Repair and maintenance to electrical components shall include initial safety checks and component inspection procedures. If a fault exists that could compromise safety, then no electrical supply shall be connected to the circuit until it is satisfactorily dealt with. If the fault cannot be corrected immediately but it is necessary to continue operation, an adequate temporary solution shall be used. This shall be reported to the owner of the equipment so all parties are advised.

Initial safety checks shall include:

- that capacitors are discharged: this shall be done in a safe manner to avoid possibility of sparking;
- that there are no live electrical components and wiring are exposed while charging, recovering or purging the system;
- that there is continuity of earth bonding;
- Sealed electrical components shall be replaced if damaged;
- Intrinsically safe components must be replaced if damaged.

13. Wiring

Check that wiring will not be subject to wear, corrosion, excessive pressure, vibration, sharp edges or any other adverse environmental effects. The check shall also take into account the effects of aging or continual vibration from sources such as compressors or fans.

14. Detection of flammable refrigerants

Under no circumstances shall potential sources of ignition be used in the searching for or detection of refrigerant leaks. A halide torch (or any other detector using a naked flame) shall not be used.

The following leak detection methods are deemed acceptable for refrigerant systems. Electronic leak detectors may be used to detect refrigerant leaks but, in the case of FLAMMABLE REFRIGERANTS, the sensitivity may not be adequate, or may need re-calibration. (Detection equipment shall be calibrated in a refrigerant-free area.) Ensure that the detector is not a potential source of ignition and is suitable for the refrigerant used. Leak detection equipment shall be set at a percentage of the LFL of the refrigerant and shall be calibrated to the refrigerant employed, and the appropriate percentage of gas (25 % maximum) is confirmed. Leak detection fluids are also suitable for use with most refrigerants but the use of detergents containing chlorine shall be avoided as the chlorine may react with the refrigerant and corrode the copper pipe-work.

NOTE Examples of leak detection fluids are

- bubble method

If a leak is suspected, all naked flames shall be removed/extinguished.

If a leakage of refrigerant is found which requires brazing, all of the refrigerant shall be recovered from the system, or isolated (by means of shut off valves) in a part of the system remote from the leak. See the following instructions of removal of refrigerant.

15. Removal and evacuation

When breaking into the refrigerant circuit to make repairs - or for any other purpose conventional procedures shall be used. However, for flammable refrigerants it is important that best practice be followed, since flammability is a consideration.

The following procedure shall be adhered to:

- safely remove refrigerant following local and national regulations;
- evacuate;
- purge the circuit with inert gas (optional for A2L);
- evacuate (optional for A2L);
- continuously flush or purge with inert gas when using flame to open circuit; and
- open the circuit.

The refrigerant charge shall be recovered into the correct recovery cylinders if venting is not allowed by local and national codes. For appliances containing flammable refrigerants, the system shall be purged with oxygen-free nitrogen to render the appliance safe for flammable refrigerants. This process might need to be repeated several times. Compressed air or oxygen shall not be used for purging refrigerant systems.

For appliances containing flammable refrigerants, refrigerants purging shall be achieved by breaking the vacuum in the system with oxygen-free nitrogen and continuing to fill until the working pressure is achieved, then venting to atmosphere, and finally pulling down to a vacuum (optional for A2L). This process shall be repeated until no refrigerant is within the system (optional for A2L). When the final oxygen-free nitrogen charge is used, the system shall be vented down to atmospheric pressure to enable work to take place.

The outlet for the vacuum pump shall not be close to any potential ignition sources, and ventilation shall be available.

17. Charging procedures

In addition to conventional charging procedures, the following requirements shall be followed:

Works shall be undertaken with appropriate tools only (In case of uncertainty, please consult the manufacturer of the tools for use with flammable refrigerants) Ensure that contamination of different refrigerants does not occur when using charging equipment. Hoses or lines shall be as short as possible to minimize the amount of refrigerant contained in them.

Cylinders shall be kept upright.

Ensure that the refrigeration system is earthed prior to charging the system with refrigerant.

Label the system when charging is complete(if not already).

Extreme care shall be taken not to overfill the refrigeration system.

Prior to recharging the system it shall be pressure tested with oxygen free nitrogen (OFN). The system shall be leak tested on completion of charging but prior to commissioning. A follow up leak test shall be carried out prior to leaving the site.

18. Decommissioning

Before carrying out this procedure, it is essential that the technician is completely familiar with the equipment and all its detail. It is recommended good practice that all refrigerants are recovered safely. Prior to the task being carried out, an oil and refrigerant sample shall be taken in case analysis is required prior to re-use of recovered refrigerant. It is essential that electrical power is available before the task is commenced.

a) Become familiar with the equipment and its operation

b) Isolate system electrical

c) Before attempting the procedure ensure that:

- mechanical handling equipment is available, if required, for handling refrigerant cylinders;
- all personal protective equipment is available and being used correctly;
- the recovery process is supervised at all times by a competent person;
- recovery equipment and cylinders conform to the appropriate standards.

d) Pump down refrigerant system, if possible

e) If a vacuum is not possible, make a manifold so that refrigerant can be removed from various parts of the system.

f) Make sure that cylinder is situated on the scales before recovery takes place

g) Start the recovery machine and operate in accordance with instruction

h) Do not overfill cylinders (no more than 80 % volume liquid charge)

i) Do not exceed the maximum working pressure of the cylinder, even temporarily

j) When the cylinders have been filled correctly and the process completed, make sure that the cylinders and the equipment are removed from site promptly and all isolation valves on the equipment are closed off.

k) Recovered refrigerant shall not be charged into another refrigeration system unless it has been cleaned and checked.

19. Labeling

Equipment shall be labelled stating that it has been de-commissioned and emptied of refrigerant. The label shall be dated and signed. For appliances containing FLAMMABLE REFRIGERANTS, ensure that there are labels on the equipment stating the equipment contains FLAMMABLE REFRIGERANT.

20. Recovery

When removing refrigerant from a system, either for servicing or decommissioning, it is recommended good practice that all refrigerants are removed safely.

When transferring refrigerant into cylinders, ensure that only appropriate refrigerant recovery cylinders are employed. Ensure that the correct number of cylinders for holding the total system charge is available. All cylinders to be used are designated for the recovered refrigerant and labelled for that refrigerant (i. e. special cylinders for the recovery of refrigerant). Cylinders shall be complete with pressure-relief valve and associated shut-off valves in good working order. Empty recovery cylinders are evacuated and, if possible, cooled before recovery occurs.

The recovery equipment shall be in good working order with a set of instructions concerning the equipment that is at hand and shall be suitable for the recovery of the flammable refrigerant. If in doubt, the manufacturer should be consulted. In addition, a set of calibrated weighing scales shall be available and in good working order. Hoses shall be complete with leak-free disconnect couplings and in good condition.

The recovered refrigerant shall be processed according to local legislation in the correct recovery cylinder, and the relevant waste transfer note arranged. Do not mix refrigerants in recovery units and especially not in cylinders.

If compressors or compressor oils are to be removed, ensure that they have been evacuated to an acceptable level to make certain that flammable refrigerant does not remain within the lubricant. The compressor body shall not be heated by an open flame or other ignition sources to accelerate this process. When oil is drained from a system, it shall be carried out safely.

21. Unventilated areas

- An unventilated area where the appliance using FLAMMABLE REFRIGERANTS is installed shall be so constructed that should any refrigerant leak, it will not stagnate so as to create a fire or explosion hazard.

- If appliances connected via an air duct system to one or more rooms with A2 REFRIGERANTS are installed in a room with an area less than A_{min} , that room shall be without continuously operating open flames (e.g. an operating gas appliance) or other POTENTIAL IGNITION SOURCES (for e.g. an operating electric heater, hot surfaces). A flame-producing device may be installed in the same space if the device is provided with an effective flame arrest .

- Auxiliary devices which may be a POTENTIAL IGNITION SOURCE shall not be installed in the duct work. Examples of such POTENTIAL IGNITION SOURCES are hot surfaces with a temperature exceeding 700 °C and electric switching devices.

- Only auxiliary devices (such as certificated heater kit) approved by the appliance manufacturer or declared suitable with the refrigerant shall be installed in connecting ductwork.

- For duct connected appliances, false ceilings or drop ceilings may be used as return air plenum if a REFRIGERANT DETECTION SYSTEM is provided in the appliance and any external connections are also provided with a sensor immediately below the return air plenum duct joint.

- REFRIGERANT SENSORS for REFRIGERANT DETECTION SYSTEMS Shall Only be replaced with sensors specified by the appliance manufacture.

- LEAK DETECTION SYSTEM installed. Unit must be powered except for service

22. Transportation, marking and storage for units that employ flammable refrigerants

a. General Information

The following information is provided for units that employ FLAMMABLE REFRIGERANTS.

b. Transport of equipment containing flammable refrigerant

Attention is drawn to the fact that additional transportation regulations may exist with respect to equipment containing flammable gas. The maximum number of pieces of equipment or the configuration of the equipment permitted to be transported together will be determined by the applicable transport regulations.

c. Marking of equipment using signs

Signs for similar appliances used in a work area are generally addressed by local regulations and give the minimum requirements for the provision of safety and/or health signs for a work location.

All required signs are to be maintained and employers should ensure that employees receive suitable and sufficient instruction and training on the meaning of appropriate safety signs and the actions that need to be taken in connection with these signs.

The effectiveness of signs should not be diminished by too many signs being placed together.

Any pictograms used should be as simple as possible and contain only essential details.

d. Disposal of equipment using flammable refrigerant

See national regulations.

e. Storage of equipment/appliance





The storage of the appliance should be in accordance with the applicable regulations or instructions, whichever is more stringent.

f. Storage of packed (unsold) equipment

Storage package protection should be constructed in such a way that mechanical damage to the equipment inside the package will not cause a leak of the REFRIGERANT CHARGE.



The maximum number of pieces of equipment permitted to be stored together will be determined by local regulations.

Explanation of symbols displayed on the indoor unit or outdoor unit

	WARNING	This symbol shows that this appliance used a flammable refrigerant. If the refrigerant is leaked and exposed to an external ignition source, there is a risk of fire.
	CAUTION	This symbol shows that the operation manual should be read carefully.
	CAUTION	This symbol shows that a service personnel should be handling this equipment with reference to the installation manual.
	CAUTION	
	CAUTION	This symbol shows that information is available such as the operating manual or installation manual.

Accessories

The quick-connect line set comes with the following accessories. Use all of the installation parts and accessories to install the air conditioner. Improper installation may result in water leakage, electrical shock and fire, or cause the equipment to fail. The items are not included must be purchased separately.

Name	Shape	Quantity (per line set)
EZ-Connect Pre-Charged Line Set		1
Sound Deadening Pads		2 (used to wrap line set quick connectors)
Insulation Sheath		2 (Apply over line set connectors and sound deadening pads to insulate piping)

Preperation & Connecting Line Set to Indoor Unit

IMPORTANT INFORMATION

- Follow the instructions fully when connecting the line set to the indoor & outdoor units. The warranty of the equipment will only be valid if the line set is installed correctly as described in the instructions.
- **DO NOT** remove the caps sealing the ends of the line set until immediately before installing the line set.
- To prevent leaks, ensure the quick-connect fittings are completely free of dirt & debris. Moisture & foreign bodies could affect the integrity of the line set connection points and lead to a loss of refrigerant, which is not covered by the warranty.
- **ONLY** install the line set outdoors during dry weather.
- **DO NOT** plaster over installed refrigerant lines.
- **DO NOT** allow refrigerant to be released in the environment, as improper handling and exposure to refrigerant may be harmful to your health.
- **ALWAYS** wear gloves and safety goggles when handling or working around refrigerant.
- **DO NOT** smoke during the installation of this equipment.
- **DO NOT** operate any of the equipment without refrigerant lines installed, otherwise the units could be damaged immediately upon startup.
- The line set connections must only be tightened using the appropriate tools (open-ended crescent wrenches/spanner and/or an HVAC torque wrench) as described in this manual.

Line Set Piping Connectors
(both ends)

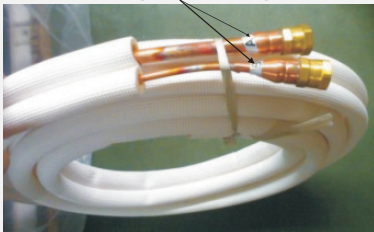

- The line set connectors **MUST** be tightened with an appropriate amount of torque to ensure they seal and function properly. If the are tightened with too little torque, it could cause refrigerant to leak. If they are tightened with too much torque, the line set connectors could sustain damage, which could also cause them to leak. If you do not feel confident connecting the line set, please contact an HVAC professional.

WARNING!

The EQ valves are only designed for one-time installation. Their seal cannot be guaranteed if they are installed more than once. If more than one installation is attempted the warranty will be voided.

Tools Required

The following tools are needed to complete the installation and connection of the DIYCOOL pre-charged line set:

- Appropriately-sized open-ended wrenches to fit the line connectors (19mm, 22mm, 24mm, 27mm, depending on capacity and line set size). NOTE: Because wrenches of these sizes may be difficult to aquire, the preferred tools are two adjustable, crescent-style wrenches as these can be adjusted to fit the different-sized connectors of the various sizes of line sets available depending on your application.
- An HVAC torque wrench (if available, but not required).
- 5mm Allen key
- Phillips head screwdriver
- Leak detection spray or soap and water mixture in a spray bottle.

STEP 1: Unwind line set to necessary length for your application

1. Carefully unwind one end of the line set to the necessary length by hand, leaving the excess and the other end of the line set to remain coiled. Ensure the unrolled end of the line set has been unwound until the connectors of that end are close to flat with the ground. This will help make it easier to connect this end of the line set to the air handler.

CAUTION!

When bending the line set, any bends should have a minimum radius of ≥ 4 in (10 cm). If the line set is bent repeatedly, it could become difficult to bend. Avoid bending/extending the line set more than 3 times, or at angles greater than 90° , as it could cause the piping to crack or break.

STEP 2: Connect Line Set to Indoor Unit

- DO NOT** remove the plastic seals from the line set connection points of the indoor unit, or from the line set connectors, until immediately before connecting the line set to the indoor unit.
- Align the line set connectors with each corresponding connection port on the air handler. Ensure the dimensions of each of the line set connectors match the dimensions of the connection ports of the air handler.
- Now, remove the seals from the end of the line set, as well as the connection ports of the air handler.
- Place the screw connector of one the line set pipes onto the threads of the connection port of the air handler and tighten the first few threads by hand, while ensuring that the orientation of the screw connector stays in alignment with the connection port of the air handler and cross-threading does not occur.



- Using the image below, and in the next column above, as a guide hold the connection points marked "1" and "2" in the image below using two open-ended crescent style wrenches. Carefully tighten the screw connection of the line set by turning the wrench held at point "2" clockwise. Continue to tighten the connector until it becomes snug. **NOTE: Work quickly and check the line set connector as you tighten it to make sure it does not become crooked.**

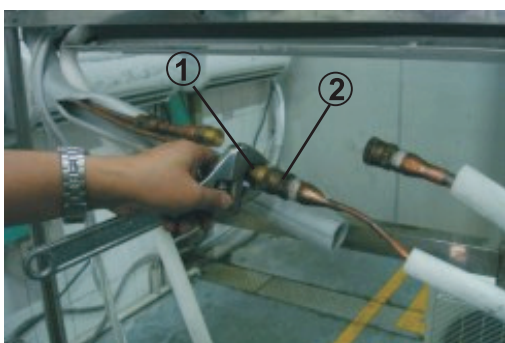

- Once the connector is snug, if an HVAC torque wrench is available torque the connector to specified torque rating in the table below (torque rating is based on the size of the connector). If an HVAC torque wrench is not available, once the the connector is snug continue tightening the connector using the two wrenches (as shown in the image above) beyond that point slightly to apply torque to the connector, but do not overtighten it.
- Now, using leak detection spray or a soapy water solution in a spray bottle, spray the connections. If any bubbles appear, it indicates there is a leak and the connection needs to be retightened.
- Repeat the steps 1-7 for the second line.

Torque Ratings for Line Set Connectors		
Coupling (last 2 digits on connector)	Coupling Size inch (millimeter)	Torque Rating foot-pound (newton-meters)
06	1/4 in (6.35 mm)	18-20 lb/ft (24.4-27.1 Nm)
09	3/8 in (9.62 mm)	30-35 lb/ft (40.6-47.4 Nm)
12	1/2 in (12.7 mm)	45-50 lb/ft (61.0-67.7 Nm)
16	5/8 in (15.88 mm)	60-65 lb/ft (81.3-88.1 Nm)
19	3/4 in (19.05 mm)	33 lb/ft (45 Nm)*

*Testing this size line set connector for the maximum allowable torque rating could not be performed, so only the minimum recommended torque amount has been provided.

WARNING!

- DO NOT** exceed the torque ratings in the table above. Excessive torque will damage the piping.
- If a torque wrench is used it must be an open-ended style HVAC torque wrench (available from online retailers). A socket-style automotive torque wrench will not work.
- If an HVAC torque wrench is not available, it is possible to correctly torque the line set connectors using two adjustable, crescent-style open-ended wrenches.
- Once the line set is connected, it is important to check every connection point for leaks.

Connecting Line Set to Outdoor Unit

STEP 1: Remove condenser water tray and ensure check valves are tight.

1. Remove water tray (if applicable) from the outdoor unit as shown in the image below.

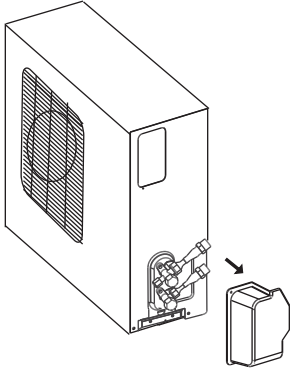

2. Before the line set can be connected to the condenser you must ensure the check valves and shut-off valve are tight. Using the open-ended wrenches you used in the previous steps check the tightness of each of the check valves and shut-off valve. If the valves are loose, turn the wrench clockwise as depicted by the arrows in the image below to secure the valves. If the valves are not secured this could create an area for a potential refrigerant leak to occur. **NOTE: If installing a multi-zone condenser, there will be multiple check valves for each air handler connection point that will need to be checked for tightness (also depicted in the image below).**



NOTE: All images and illustrations depicted in this manual are for explanatory purposes only, The actual shape and size of the equipment purchased for your application may vary or differ.

STEP 2: Connect Line Set to Outdoor Unit

1. **DO NOT** remove the plastic seals from the line set connection points of the outdoor unit, or from the line set connectors, until immediately before connecting the line set to the outdoor unit.
2. Align the line set connectors of the coiled end of the line set with each corresponding valve on the condenser. **NOTE: Make sure the line set and connectors can be connected easily to the condenser valves with as little stress as possible placed on the line set. Some light bending of the line set piping may be necessary in order for this to occur.**
3. Ensure the dimensions of each of the line set connectors match the dimensions of the valves of the outdoor unit.
4. Now, remove the seals from the end of the line set, as well as the connection ports of the air handler.

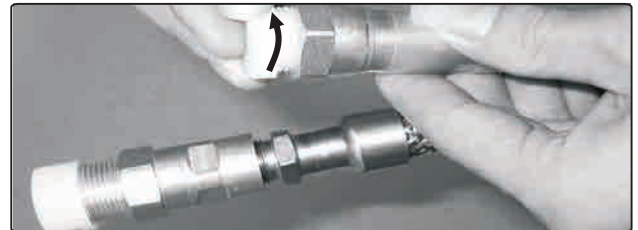

5. Place the screw connector of one the line set pipes onto the threads of the valve of the outdoor unit and tighten the first few threads by hand, while ensuring that the orientation of the screw connector stays in alignment with the valver of the condenser and cross-threading does not occur (refer to the image below).

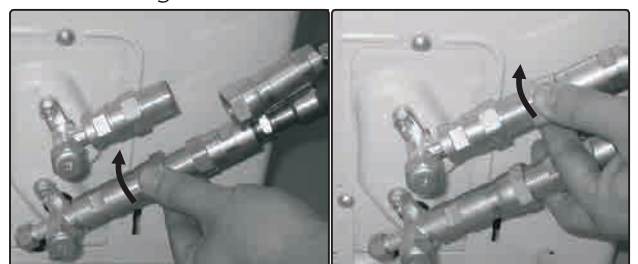

IMPORTANT!

Before you continue, it is essential you read the following instructions fully and carefully.

- Using the image below as a guide, you will tighten the bottom screw connector first. Hold the bottom screw connector at the points marked "1" and "2" using two open-ended crescent style wrenches. Carefully tighten the screw connection of the line set by turning the wrench held at point "2" clockwise. Continue to tighten the connector until it becomes snug. **NOTE: Work quickly and check the line set connector as you tighten it to make sure it does not become crooked.**

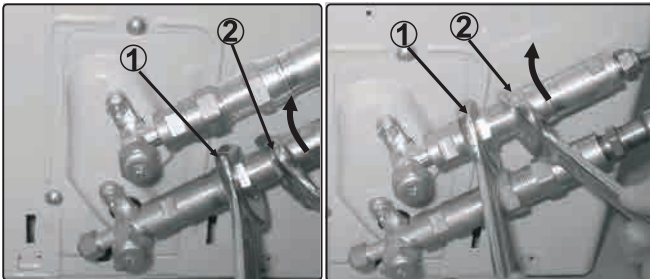

- Once the connector is snug, if an HVAC torque wrench is available torque the connector to specified torque rating in the table below (torque rating is based on the size of the connector). If an HVAC torque wrench is not available, once the the connector is snug continue tightening the connector using the two wrenches (as shown in the image above) beyond that point slightly to apply torque to the connector, but do not overtighten it.

Torque Ratings for Line Set Connectors		
Coupling (last 2 digits on connector)	Coupling Size inch (millimeter)	Torque Rating foot-pound (newton-meters)
06	1/4 in (6.35 mm)	18-20 lb/ft (24.4-27.1 Nm)
09	3/8 in (9.62 mm)	30-35 lb/ft (40.6-47.4 Nm)
12	1/2 in (12.7 mm)	45-50 lb/ft (61.0-67.7 Nm)
16	5/8 in (15.88 mm)	60-65 lb/ft (81.3-88.1 Nm)
19	3/4 in (19.05 mm)	33 lb/ft* (45 Nm)*

*Testing this size line set connector for the maximum allowable torque rating could not be performed, so only the minimum recommended torque amount has been provided.

IMPORTANT!

The coupling inside the connector uses tapping rings. If you attempt to loosen and reconnect the piping it could cause it to leak. This will also void the warranty.

- Now, using leak detection spray or a soapy water solution in a spray bottle, spray the connections. If any bubbles appear, it indicates there is a leak and the connection needs to be retightened.
- Repeat the same process for the second line.
- If you're installing a multi-zone system, with multiple air handlers, repeat steps 1-9 with each air handler being connected to the condenser before progressing to the next step.

STEP 3: Opening condenser refrigerant valves

- Using the images below as a guide, remove the cover on the top valve using an open-ended wrench.
- Then, insert a 5 mm Allen key into the valve and open it by turning it counter-clockwise as far as it will turn. The valve is now open. **DO NOT force it, as this could cause damage to the valve and cause it to leak.**
- Screw the cap back onto the valve and tighten it using the wrench to ensure it is properly sealed.

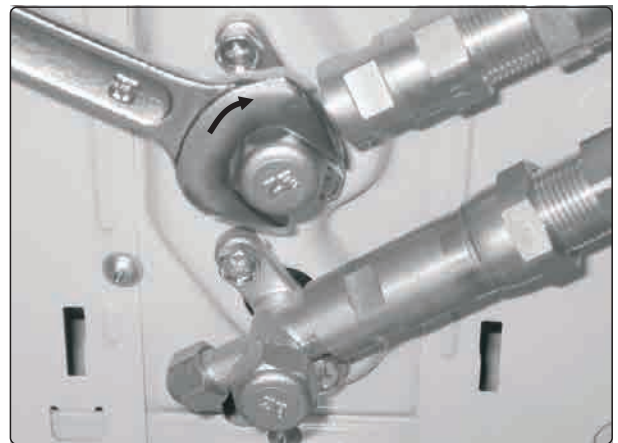
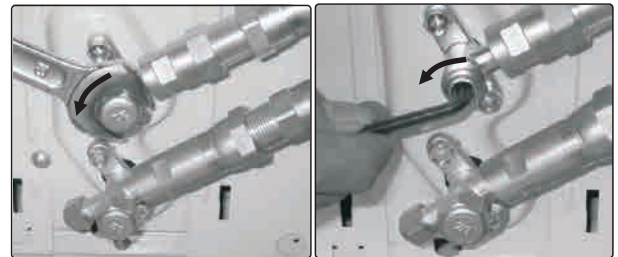

IMPORTANT!

The conical ring on the valve has an important sealing function together with the sealing seat within the caps. Ensure that you do not damage the cone when completing these steps and you keep the cap free from dirt, dust, or debris.

- Using the images below as a guide, remove the cover on the bottom valve using an open-ended wrench.
- Then, insert a 5 mm Allen key into the valve and open it by turning it counter-clockwise as far as it will turn. The valve is now open.

DO NOT force it, as this could cause damage to the valve and cause it to leak.

- Screw the cap back onto the valve and tighten it using the wrench to ensure it is properly sealed.

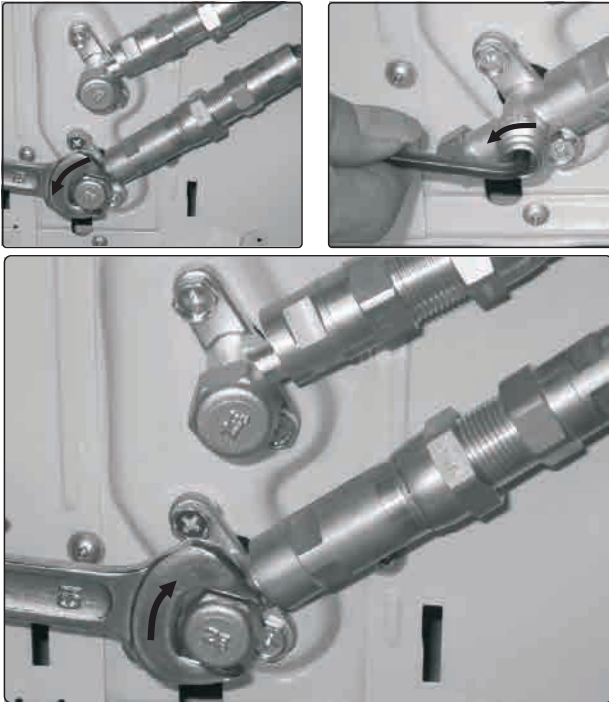

- Now, using leak detection spray or a soapy water solution in a spray bottle, respray the connections. If any bubbles appear it indicates there is a leak and the connection needs to be retightened.
- If you're installing a multi-zone system, with multiple air handlers, repeat steps 1-7 with each of the valves for each air handler being connected to the condenser before progressing to the next step.

IMPORTANT!

If all valves are not fully opened, the system may malfunction and suffer damage.

STEP 4: Opening the King Valves (dependent upon type of unit & capacity)

- Depending on your application, some multi-zone condensers are equipped with two additional main valves, referred to as King Valves (please refer to image below). If your condenser is equipped with King Valves these will also need to be opened before proceeding. The king valves are opened by following the previous steps for the opening the other valves. **If your condenser is not equipped with King Valves, please proceed to the next step.**

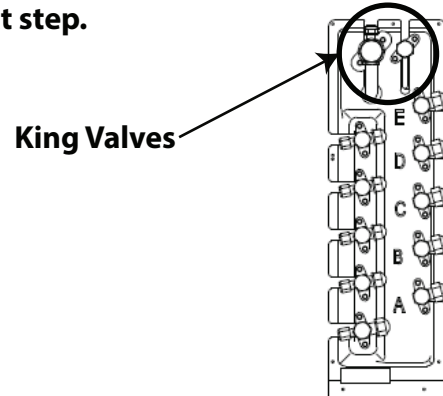

Side View of Multi-Zone Condenser

STEP 5: Starting system and rechecking all connections for leaks.

WARNING!

- DO NOT** attempt this step until all other steps contained within all manuals provided have been completed. Ensure all electrical work is completed and conforms to all regional & national codes, and the indoor and outdoor units have been fully installed. The following steps require starting the system so that system pressure will build and the entire system can be rechecked for leaks. If the system is started without all work completed, damage to the unit and potential bodily injury could occur.
- As system pressure increases, it could reveal leaks that were not initially present which is why rechecking all of the line set connections and valves for leaks is essential. If any leaks are found, turn off the system, retighten the leaking connection and repeat this step. Please refer to the Electrical & Gas Leak Checks & Test Run sections of this manual for more information.

- Start the system. Then, using leak detection spray or a soapy water solution in a spray bottle, spray all the line set connections and valves. If any bubbles appear it indicates there is a leak. Stop the system retightened any leaking connections and repeat this step.
- Reinstall condenser water tray (if applicable).

Wrapping & Insulating Line Set Connections

STEP 1: Install sound deadening pads over line set connectors

1. Once the system has been checked and no leaks are found, wrap all of the indoor air handler line set connectors with the adhesive sound deadening pads tightly (refer to the image below). These will prevent the line set connectors from being exposed to the air and aid in protecting them from any other external elements.



STEP 2: Insulate line set connection with insulation material

1. Then, using the black insulation material wrap around the line set connection and sound deadening pad with the opening of the insulation pointed toward the upward (Refer to image below).
2. Now, cover the opening of the black insulation material and exposed portion of the line set with the white insulation material to wrap up the line set connection completely (refer to the image below).



STEP 3: Bundle and tape line set, communication cable, and condensate drain pipe (dependent upon on application and type of installation being performed)

1. Depending upon the application and the installation being performed, you might be required to bundle the line set with the condensate drain pipe, and communication cable that connects the indoor unit to the outdoor unit (ex: to pass all of them through a hole in the wall so they can be connected to an outdoor unit). You may also be required to perform additional wrapping of this bundle with tape. If your installation or application requires this, please be sure to position the line set piping, communication cable, and condensate drain pipe in the orientation shown in the illustration below (with the condensate drain pipe at the bottom of the bundle).

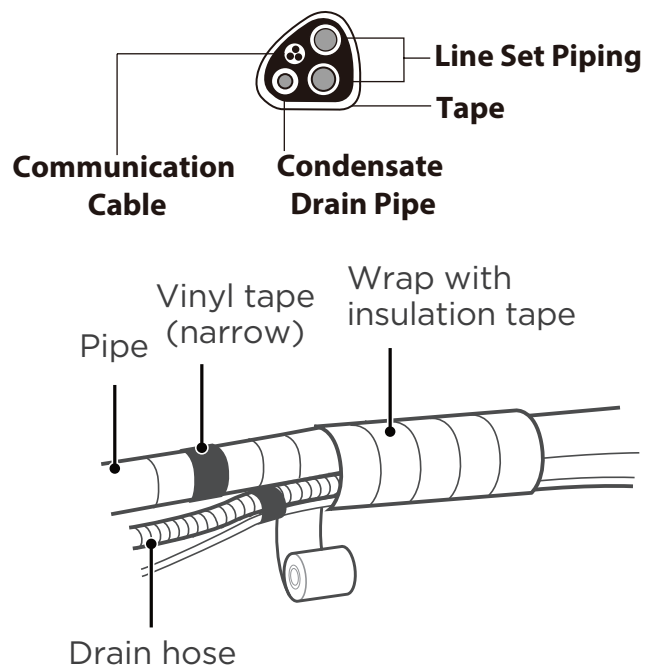

Electrical and Gas Leak Checks

Before Test Run

Only perform test run after you have completed the following steps:

- **Electrical Safety Checks** – Confirm that the unit's electrical system is safe and operating properly
- **Gas Leak Checks** – Check all flare nut connections and confirm that the system is not leaking
- Confirm that gas and liquid (high and low pressure) valves are fully open

Electrical Safety Checks

After installation, confirm that all electrical wiring is installed in accordance with local and national regulations, and according to the Installation Manual.

BEFORE TEST RUN

Check Grounding Work

Measure grounding resistance by visual detection and with grounding resistance tester. Grounding resistance must be less than 0.1 Ω .

Note: This may not be required for some locations in North America.

DURING TEST RUN

Check for Electrical Leakage

During the **Test Run**, use an electroprobe and multimeter to perform a comprehensive electrical leakage test.

If electrical leakage is detected, turn off the unit immediately and call a licensed electrician to find and resolve the cause of the leakage.

Note: This may not be required for some locations in North America.

WARNING – RISK OF ELECTRIC SHOCK

ALL WIRING MUST COMPLY WITH LOCAL AND NATIONAL ELECTRICAL CODES, AND MUST BE INSTALLED BY A LICENSED ELECTRICIAN.

Gas Leak Checks

There are two different methods to check for gas leaks.

Soap and Water Method

Using a soft brush, apply soapy water or liquid detergent to all pipe connection points on the indoor unit and outdoor unit. The presence of bubbles indicates a leak.

Leak Detector Method

If using leak detector, refer to the device's operation manual for proper usage instructions.

AFTER PERFORMING GAS LEAK CHECKS

After confirming that the all pipe connection points **DO NOT** leak, replace the valve cover on the outside unit.

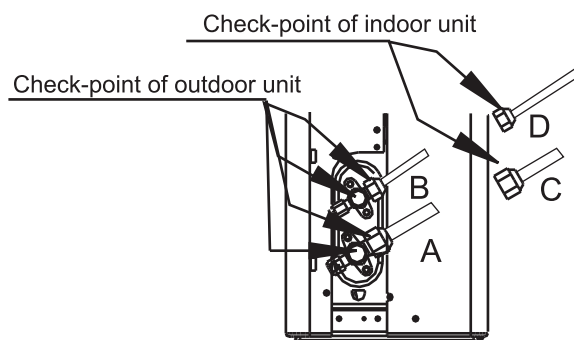

A: Low pressure stop valve
B: High pressure stop valve
C & D: Indoor unit flare nuts

Test Run

Test Run Instructions

You should perform the **Test Run** for at least 30 minutes.

1. Connect power to the unit.
2. Press the **ON/OFF** button on the remote controller to turn it on.
3. Press the **MODE** button to scroll through the following functions, one at a time:
 - COOL – Select lowest possible temperature
 - HEAT – Select highest possible temperature
4. Let each function run for 5 minutes, and perform the following checks:

List of Checks to Perform	PASS/FAIL	
No electrical leakage		
Unit is properly grounded		
All electrical terminals properly covered		
Indoor and outdoor units are solidly installed		
All pipe connection points do not leak	Outdoor (2):	Indoor (2):
Water drains properly from drain hose		
All piping is properly insulated		
Unit performs COOL function properly		
Unit performs HEAT function properly		
Indoor unit louvers rotate properly		
Indoor unit responds to remote controller		

DOUBLE-CHECK PIPE CONNECTIONS

During operation, the pressure of the refrigerant circuit will increase. This may reveal leaks that were not present during your initial leak check. Take time during the Test Run to double-check that all refrigerant pipe connection points do not have leaks. Refer to **Gas Leak Check** section for instructions.

5. After the Test Run is successfully completed, and you confirm that all checks points in List of Checks to Perform have PASSED, do the following:
 - a. Using remote control, return unit to normal operating temperature.
 - b. Using insulation tape, wrap the indoor refrigerant pipe connections that you left uncovered during the indoor unit installation process.

NOTES



STEALTH®

Any instructions, designs, or specifications contained in this manual for the products, systems, or any associated accessories covered within it, are subject to change without prior notice due to constant product improvement. Consult with the sales agency or manufacturer for details. All materials for Stealth products are available on the company website. Please consult the Stealth website to ensure you have the latest version of this manual.
