



OIL FIRED LOWBOY FURNACE SPECIFICATIONS

MODEL NO.	VLF-DBP (Front Flue) or VLR-DBP (Rear Flue) (BECKETT AFG)				VLF-DCP (Front Flue) or VLR-DCP (Rear Flue) (CARLIN EZ-1HP)			
	High Fire	Med-High Fire	Med-Low Fire [5]	Low Fire	High Fire	Med-High Fire	Med-Low Fire [5]	Low Fire
HEATING CAPACITY								
HEAT INPUT RATE (BTUH)	140,000	119,000	105,000	84,000	140,000	119,000	105,000	84,000
OUTPUT BTUH [1]	114,000	98,000	88,000	70,000	114,000	98,000	88,000	70,000
SEASONAL EFFICIENCY [2]	85.00%				86.00%			
LARGEST REC A/C	4 Tons				4 Tons			
NOMINAL TEMP RISE	70° F				70° F			
HEAT EXCHANGER AREA (SQ. FT.)	27.8 (front flue) / 30.0 (rear flue)				27.8 (front flue) / 30.0 (rear flue)			
CASING HEIGHT	41.5"				41.5"			
CASING WIDTH	22.25"				22.25"			
CASING DEPTH	47"				47"			
NOMINAL FLUE OUTLET DIA.	6"				6"			
APPROX SHIPPING WEIGHT (LBS)	300				300			
APPROVAL AGENCY	ETL				ETL			
QTY AND SIZE OF PERMANENT FILTERS	(2) 10" X 20"				(2) 10" X 20"			
ELECTRICAL REQUIREMENTS	120v / 60hz / 1ph				120v / 60hz / 1ph			
TOTAL CURRENT (AMPS)	11.2				11.2			
MAX FUSE SIZE (AMPS)	15				15			
HEIGHT FROM FLOOR TO CENTER OF FLUE	30.375"				30.375"			
SUPPLY AIR OUTLET SIZE	20" X 20"				20" X 20"			
RETURN AIR INLET SIZE	20" x 12.5"				20" x 12.5"			
	ACCESSORY ITEMS				ACCESSORY ITEMS			
FURNACE PARTS KIT	AOPS2695				-			
BURNER FRESH AIR VENT KIT	AOPS7482				AOPS7482			
BLOCKED VENT KIT [4]	AOPS2686				AOPS2686			

1 OUTPUT BTUH BASED ON ANNUAL FUEL UTILIZATION EFFICIENCY RATED BY MANUFACTURER.

2 SEASONAL EFFICIENCY (ALSO CALLED AFUE - ANNUAL FUEL UTILIZATION EFFICIENCY) RATINGS ARE BASED ON TESTS FOLLOWING U.S. DEPARTMENT OF ENERGY TEST PROCEDURES.

4 NOT TO BE USED IN SIDEWALL VENT APPLICATIONS, USE ONLY WHEN CHIMNEY VENTED.

5 AFUE RATINGS AS SHIPPED.

SEE NEXT PAGE FOR MORE DATA-

OIL FIRED HORIZONTAL/COUNTERFLOW FURNACE SPECIFICATIONS

MODEL NO.	VC-CBP (BECKETT AFG)			
HEATING CAPACITY		Med-High Fire	Med-Low Fire [5]	Low Fire
HEAT INPUT RATE (BTUH)		119,000	105,000	84,000
OUTPUT BTUH[1]		97,000	88,000	69,000
SEASONAL EFFICIENCY [2]	85.0%			
LARGEST REC A/C[3]	4 Tons			
NOMINAL TEMP RISE		70°	62°	70°
HEAT EXCHANGER AREA (SQ. FT.)	27.8			
CASING HEIGHT	22.25" (in horizontal configuration, flue exits horizontally forward)			
	61.25" (in counterflow /vertical configuration)			
CASING WIDTH	61.25" (in horizontal configuration)"			
	22.25" (in counterflow /vertical configuration)			
CASING DEPTH	22.25"			
NOMINAL FLUE OUTLET DIA.	6"			
APPROX SHIPPING WEIGHT (LBS)	280			
APPROVAL AGENCY	ETL			
QTY AND SIZE OF PERMANENT FILTERS	NONE SUPPLIED			
ELECTRICAL REQUIREMENTS	120v / 60hz / 1ph			
TOTAL CURRENT (AMPS)	10.2			
MAX FUSE SIZE (AMPS)	15			
HEIGHT FROM FLOOR TO CENTER OF FLUE SIDE/TOP	11" (in horizontal configuration flue exits horizontally forward)			
	30.5" (in counterflow /vertical configuration, flue exits horizontally)			
SUPPLY AIR OUTLET SIZE	16" X 16"			
RETURN AIR INLET SIZE	16" X 16"			
	ACCESSORY ITEMS			
FURNACE PARTS KIT	AOPS2695			
COMBUSTIBLE FLOOR BASE	VC-BASE			
OPTIONAL 4 TON AIRFLOW KIT	S00S4140			
BURNER FRESH AIR VENT KIT	AOPS7482			
BLOCKED VENT KIT[4]	AOPS2687			

1 OUTPUT BTUH BASED ON ANNUAL FUEL UTILIZATION EFFICIENCY RATED BY MANUFACTURER.

2 SEASONAL EFFICIENCY (ALSO CALLED AFUE - ANNUAL FUEL UTILIZATION EFFICIENCY) RATINGS ARE BASED ON TESTS FOLLOWING U.S. DEPARTMENT OF ENERGY TEST PROCEDURES.

3 TO PERMIT LARGEST RECOMMENDED AIR CONDITIONING (AT .5 STATIC PRESSURE), OPTIONAL BLOWER UPGRADE KIT IS REQUIRED

4 NOT TO BE USED IN SIDEWALL VENT APPLICATIONS, USE ONLY WHEN CHIMNEY VENTED.

5 AFUE RATINGS AS SHIPPED.

SEE NEXT PAGE FOR MORE DATA-

Model Number Digit	1	2	3		4	5	6
	Model	Configuration	Flue		Design Change	Burner	Blower Motor
Oil Furnace Model Nomenclature Example Model Numbers	V	L	F	-	D	B	P
V=Product Line Designation	V						
L = Lowboy, C = Counterflow/Horizontal		L					
F = Front, R = Rear (VL series option only)			F				
				-			
Design Change					D		
Burner Type: B = Beckett AFG, C = Carlin						B	
Motor Type: P=PSC, T= CTM (Constant torque ECM)							P

SEE NEXT PAGE FOR MORE DATA-

OIL FIRED LOWBOY FRONT FLUE FURNACE SPECIFICATIONS

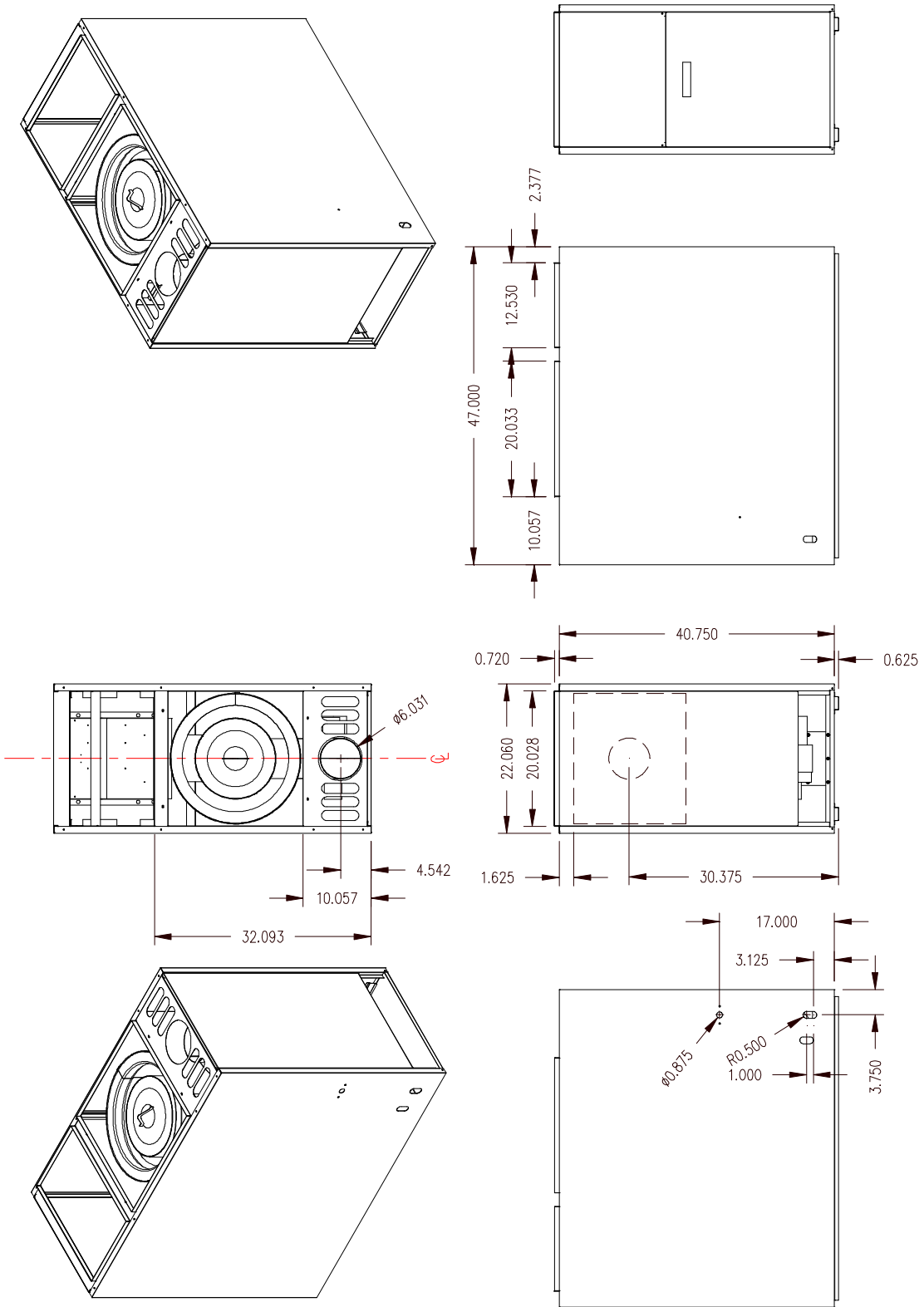

SEE NEXT PAGE FOR MORE DATA-

OIL FIRED LOWBOY REAR FLUE FURNACE SPECIFICATIONS

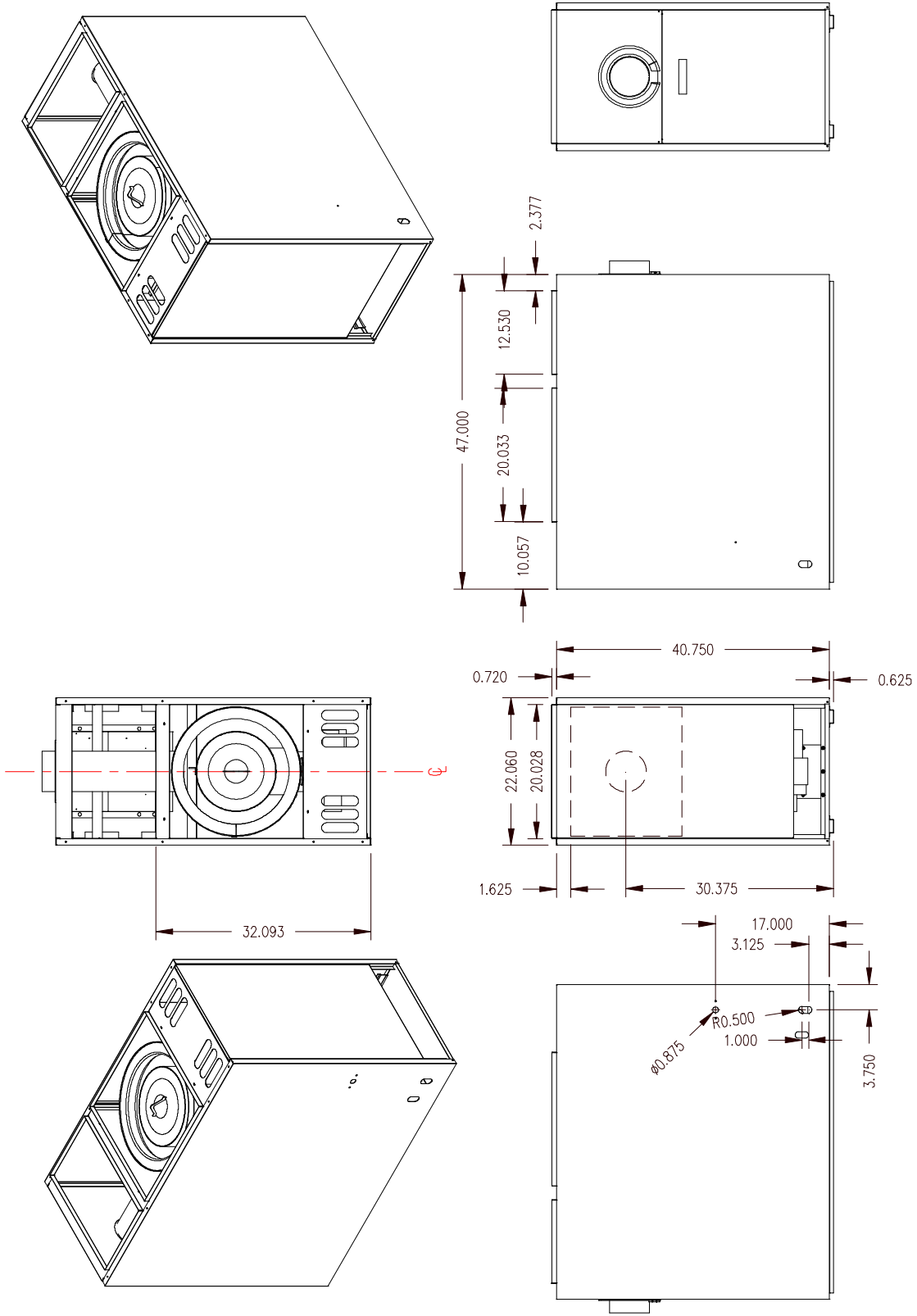

SEE NEXT PAGE FOR MORE DATA-

OIL FIRED HORIZONTAL/COUNTERFLOW FURNACE SPECIFICATIONS

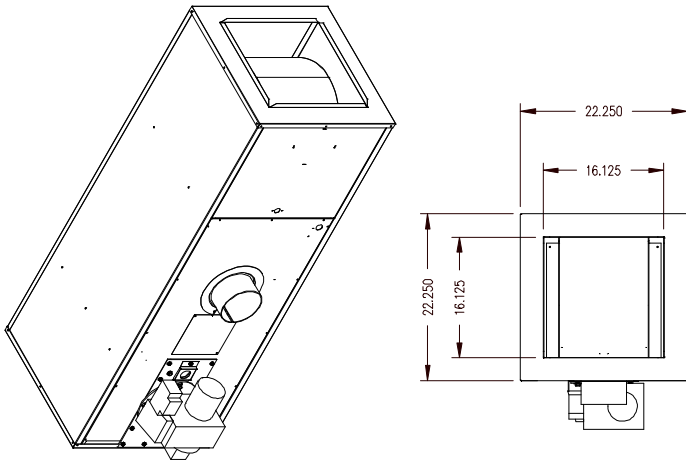

COMBUSTIBLE FLOOR BASE

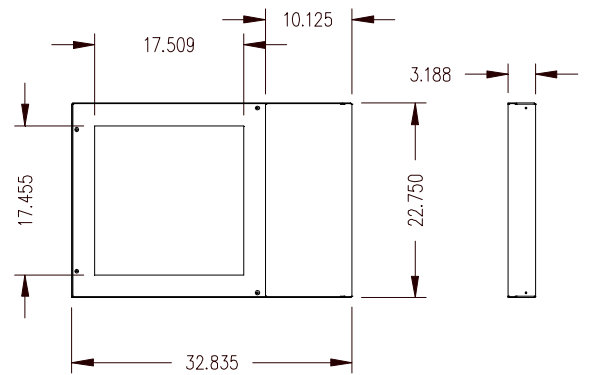
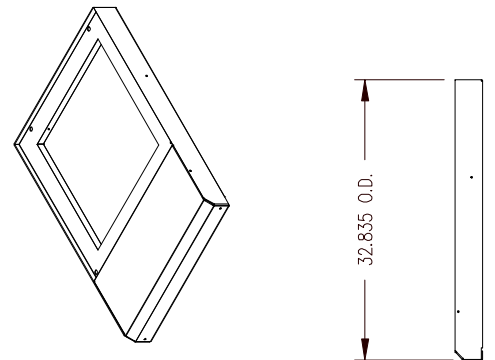
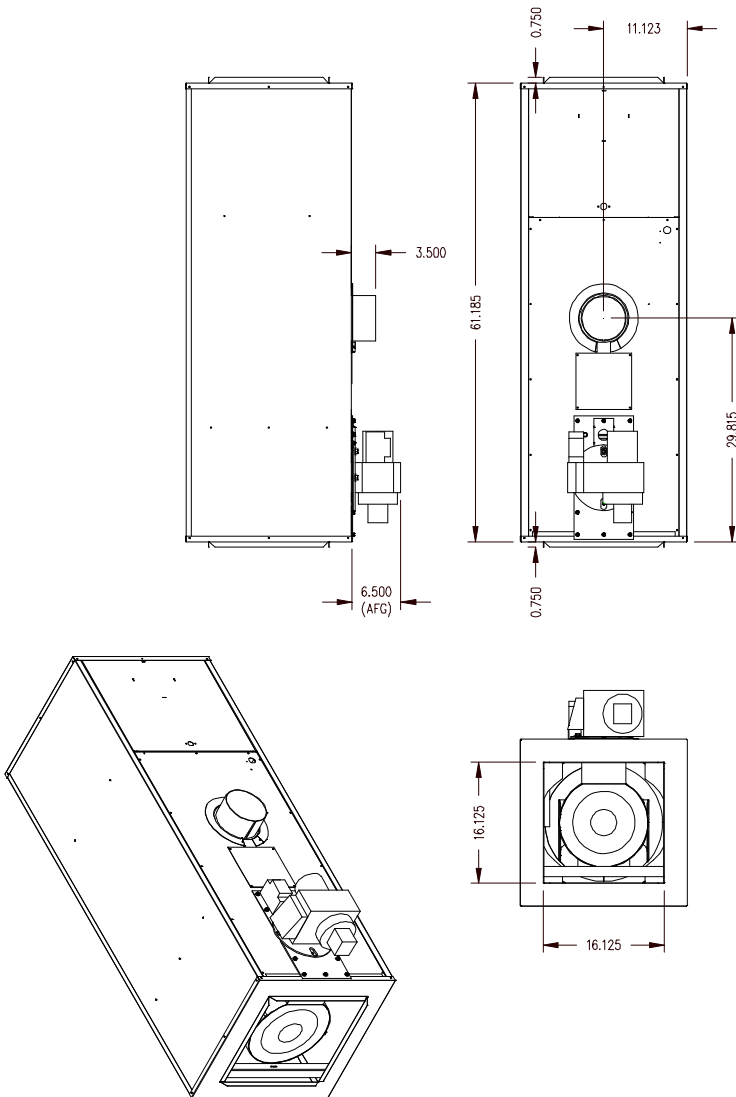

SEE NEXT PAGE FOR MORE DATA-

BLOWER DATA:	VLF-D*P	VLR-D*P	VC-CBP
BLOWER MODEL DIRECT DRIVE	10-9R		
MOTOR H.P.	3/4 HP	3/4 HP	1/2 HP
MOTOR TYPE & NUMBER OF SPEEDS	Permanent split capacitor, 4		
HIGH SPEED AIRFLOW (SCFM) @ 0.5 IN. W.G. EXTERNAL STATIC PRESSURE:	1500	1500	1350

BLOWER DATA:	N/A	N/A	VC-CBP
OPTIONAL 4TON AIRFLOW KIT			
BLOWER MODEL DIRECT DRIVE			12-9T
MOTOR H.P.			¾ HP
MOTOR TYPE & NUMBER OF SPEEDS			PSC-4
HIGH SPEED AIRFLOW (SCFM) @ 0.5 IN. W.G. EXTERNAL STATIC PRESSURE:			1648

BURNER DATA	R.W. BECKETT pressure atomizing type, Model AFG			
AIR TUBE LENGTH (IN.)	5.875, effective			
BURNER HEAD TYPE:	Fixed, flame retention			
FUEL TYPE:	#2 distillate (domestic heating oil)			
NOZZLE RATING (GPH):	1.0	0.85	0.75	0.6
SPRAY ANGLE (DEG.):	80°			
SPRAY PATTERN:	HOLLOW (A)			
OIL PUMP PRESSURE (PSIG):	130 PSI			
COMBUSTION CHAMBER TYPE:	Preformed, refractory (ceramic fiber matrix material)			

BURNER DATA	CARLIN EZ-1HP			
AIR TUBE LENGTH (IN.)	5.875, effective			
BURNER HEAD TYPE:	N/A			
FUEL TYPE:	#2 distillate (domestic heating oil)			
NOZZLE RATING (GPH):	0.85	0.75	0.65	0.55
SPRAY ANGLE (DEG.):	60°	60°	60°	70°
SPRAY PATTERN:	HOLLOW (A)			
OIL PUMP PRESSURE (PSIG):	140 PSI			
COMBUSTION CHAMBER TYPE:	Preformed, refractory (ceramic fiber matrix material)			

CLEARANCES	VLF-D*P	VLR-D*P	VC-CBP
	MINIMUM CLEARANCES TO COMBUSTIBLE MATERIALS:		
SIDES	3"	3"	3"
FRONT (SERVICE ACCESS)	8"	3"	22"
REAR	3"	3"	3"
FLUE	9"	9"	9"
TOP PLENUM	3"	3"	3"
SIDES PLENUM	3"	3"	3"

SEE NEXT PAGE FOR MORE DATA-

**VLF-D*P
4 Ton**

ALTERATIONS REQ'D FOR A/C @ DESIGN EXTERNAL STATIC PRESSURE					
COOLING UNIT	Heating Speed by Input				Recommended CLG Speed
	Low Fire	ML Fire	MH Fire	High Fire	
	84,000	105,000	119,000	140,000	
24,000	Low	ML	MH	High	Low
30,000	Low	ML	MH	High	Low
36,000	Low	ML	MH	High	ML
42,000	Low	ML	MH	High	MH
48,000	Low	ML	MH	High	High

Speed Tap\ Static Pressure	Furnace Airflow (CFM) vs. External Static pressure (in. WC.)						
	0.1	0.2	0.3	0.4	0.5	0.6	0.7
Low	1103	1106	1080	1056	1023	981	858
ML	1358	1339	1309	1264	1216	1167	1098
MH	1620	1572	1511	1443	1376	1311	1224
High	1920	1822	1730	1649	1564	1483	1397
	Blower Motor Current Draw (Amps) vs. External Static Pressure (in. WC.)						
	0.1	0.2	0.3	0.4	0.5	0.6	0.7
Low	5.39	5.12	4.86	4.64	4.37	4.16	3.70
ML	6.55	6.33	6.04	5.72	5.44	5.11	4.80
MH	7.68	7.24	6.92	6.56	6.21	5.93	5.54
High	11.3	11	10.7	10.5	10.3	10.1	9.98

SEE NEXT PAGE FOR MORE DATA -

VLF-D*P 4 Ton

Speed Tap\ Static Pressure	High Fire (140,000 BTU/HR Input) Temp Rise vs. External Static pressure (in. WC.)						
	0.1	0.2	0.3	0.4	0.5	0.6	0.7
Low	96	95	98	100	103	108	123
ML	78	79	81	84	87	90	96
MH	65	67	70	73	77	81	86
High	55	58	61	64	67	71	76

Speed Tap\ Static Pressure	Med-High Fire (119,000 BTU/HR Input) Temp Rise vs. External Static pressure (in. WC.)						
	0.1	0.2	0.3	0.4	0.5	0.6	0.7
Low	82	82	84	86	89	92	106
ML	67	68	69	72	75	78	83
MH	56	58	60	63	66	69	74
High	47	50	52	55	58	61	65

Speed Tap\ Static Pressure	Med-Low Fire (105,000 BTU/HR Input) Temp Rise vs. External Static pressure (in. WC.)						
	0.1	0.2	0.3	0.4	0.5	0.6	0.7
Low	73	73	75	76	79	82	94
ML	59	60	62	64	66	69	73
MH	50	51	53	56	59	61	66
High	42	44	47	49	52	54	58

Speed Tap\ Static Pressure	Low Fire (84,000 BTU/HR Input) Temp Rise vs. External Static pressure (in. WC.)						
	0.1	0.2	0.3	0.4	0.5	0.6	0.7
Low	59	59	60	61	63	66	76
ML	48	48	50	51	53	56	59
MH	40	41	43	45	47	49	53
High	34	36	37	39	41	44	46



Recommended Operation Range

SEE NEXT PAGE FOR MORE DATA –

**VLR-D*P
4 Ton**

ALTERATIONS REQ'D FOR A/C @ DESIGN EXTERNAL STATIC PRESSURE					
COOLING UNIT	Heating Speed by Input				Recommended CLG Speed
	Low Fire	ML Fire	MH Fire	High Fire	
	84,000	105,000	119,000	140,000	
24,000	Low	ML	MH	High	Low
30,000	Low	ML	MH	High	Low
36,000	Low	ML	MH	High	ML
42,000	Low	ML	MH	High	MH
48,000	Low	ML	MH	High	High

Speed Tap\ Static Pressure	Furnace Airflow (CFM) vs. External Static pressure (in. WC.)						
	0.1	0.2	0.3	0.4	0.5	0.6	0.7
Low	1110	1107	1091	1068	1031	973	887
ML	1366	1330	1303	1247	1187	1124	1046
MH	1622	1545	1484	1419	1356	1274	1172
High	1844	1771	1694	1612	1538	1451	1355
	Blower Motor Current Draw (Amps) vs. External Static Pressure (in. WC.)						
	0.1	0.2	0.3	0.4	0.5	0.6	0.7
Low	5.34	5.2	4.95	4.76	4.5	4.19	3.86
ML	6.33	6.15	5.86	5.48	5.18	4.83	4.57
MH	7.61	7.11	6.72	6.34	6.08	5.74	5.36
High	11	10.8	10.6	10.4	10.2	10	9.9

SEE NEXT PAGE FOR MORE DATA –

VLR-D*P 4 Ton

Speed Tap\ Static Pressure	High Fire (140,000 BTU/HR Input) Temp Rise vs. External Static pressure (in. WC.)						
	0.1	0.2	0.3	0.4	0.5	0.6	0.7
Low	95	95	97	99	102	108	119
ML	77	79	81	85	89	94	101
MH	65	68	71	74	78	83	90
High	57	60	62	65	69	73	78

Speed Tap\ Static Pressure	Med-High Fire (119,000 BTU/HR Input) Temp Rise vs. External Static pressure (in. WC.)						
	0.1	0.2	0.3	0.4	0.5	0.6	0.7
Low	82	82	83	85	88	93	102
ML	66	68	70	73	76	81	87
MH	56	59	61	64	67	71	77
High	49	51	54	56	59	63	67

Speed Tap\ Static Pressure	Med-Low Fire (105,000 BTU/HR Input) Temp Rise vs. External Static pressure (in. WC.)						
	0.1	0.2	0.3	0.4	0.5	0.6	0.7
Low	73	73	74	75	78	83	91
ML	59	61	62	65	68	72	77
MH	50	52	54	57	59	63	69
High	44	45	48	50	52	56	59

Speed Tap\ Static Pressure	Low Fire (84,000 BTU/HR Input) Temp Rise vs. External Static pressure (in. WC.)						
	0.1	0.2	0.3	0.4	0.5	0.6	0.7
Low	58	59	59	61	63	67	73
ML	47	49	50	52	55	58	62
MH	40	42	44	46	48	51	55
High	35	37	38	40	42	45	48



Recommended Operation Range

SEE NEXT PAGE FOR MORE DATA –

**VC-CBP
3.5 Ton**

ALTERATIONS REQ'D FOR A/C @ DESIGN EXTERNAL STATIC PRESSURE					
COOLING UNIT	Heating Speed by Input				Recommended CLG Speed
	Low Fire	ML Fire	MH Fire	High Fire	
	80,000	105,000	119,000		
24,000	Low	ML	MH		Low
30,000	Low	ML	MH		Low
36,000	Low	ML	MH		MH
42,000	Low	ML	MH		High
48,000					

Speed Tap\ Static Pressure	Furnace Airflow (CFM) vs. External Static pressure (in. WC.)						
	0.1	0.2	0.3	0.4	0.5	0.6	0.7
Low	1166	1139	1107	1064	1017	955	871
ML	1320	1274	1228	1176	1111	1043	950
MH	1447	1397	1343	1284	1209	1127	1043
High	1616	1550	1482	1406	1347	1231	1144
	Blower Motor Current Draw (Amps) vs. External Static Pressure (in. WC.)						
	0.1	0.2	0.3	0.4	0.5	0.6	0.7
Low	4.66	4.43	4.24	4.00	3.78	3.56	3.29
ML	5.19	4.87	4.63	4.39	4.14	3.91	3.65
MH	5.70	5.41	5.17	4.88	4.64	4.40	4.17
High	7.15	6.92	6.72	6.52	6.36	6.09	5.93

SEE NEXT PAGE FOR MORE DATA –

VC-CBP 3.5 Ton

Speed Tap\ Static Pressure	Med-High Fire (119,000 BTU/HR Input) Temp Rise vs. External Static pressure (in. WC.)						
	0.1	0.2	0.3	0.4	0.5	0.6	0.7
Low	78	80	82	85	89	95	104
ML	69	71	74	77	82	87	96
MH	63	65	68	71	75	81	87
High	56	59	61	65	67	74	79

Speed Tap\ Static Pressure	Med-Low Fire (105,000 BTU/HR Input) Temp Rise vs. External Static pressure (in. WC.)						
	0.1	0.2	0.3	0.4	0.5	0.6	0.7
Low	69	71	73	76	79	84	92
ML	61	63	66	68	73	77	85
MH	56	58	60	63	67	71	77
High	50	52	54	57	60	65	70

Speed Tap\ Static Pressure	Low Fire (84,000 BTU/HR Input) Temp Rise vs. External Static pressure (in. WC.)						
	0.1	0.2	0.3	0.4	0.5	0.6	0.7
Low	56	57	59	61	64	68	74
ML	49	51	53	55	58	62	68
MH	45	46	48	50	54	58	62
High	40	42	44	46	48	53	57



Recommended Operation Range

SEE NEXT PAGE FOR MORE DATA –

VC-CBP 4 Ton

ALTERATIONS REQ'D FOR A/C @ DESIGN EXTERNAL STATIC PRESSURE					
COOLING UNIT	Heating Speed by Input				Recommended CLG Speed
	Low Fire	ML Fire	MH Fire	High Fire	
	84,000	105,000	119,000		
24,000	Low	ML	MH		Low
30,000	Low	ML	MH		Low
36,000	Low	ML	MH		ML
42,000	Low	ML	MH		MH
48,000	Low	ML	MH		High

Speed Tap\ Static Pressure	Furnace Airflow (CFM) vs. External Static pressure (in. WC.)						
	0.1	0.2	0.3	0.4	0.5	0.6	0.7
Low	1116	1105	1084	1058	1038	1001	955
ML	1355	1342	1311	1273	1230	1183	1133
MH	1615	1572	1521	1468	1412	1355	1308
High	1901	1837	1790	1714	1648	1584	1496
	Blower Motor Current Draw (Amps) vs. External Static Pressure (in. WC.)						
	0.1	0.2	0.3	0.4	0.5	0.6	0.7
Low	5.21	5.05	4.91	4.73	4.62	4.40	4.18
ML	6.29	6.07	5.88	5.69	5.48	5.21	5.01
MH	7.47	7.18	6.93	6.63	6.33	6.15	5.92
High	11.1	11.0	10.8	10.6	10.5	10.4	10.1

SEE NEXT PAGE FOR MORE DATA –

VC-CBP 4 Ton

Speed Tap\ Static Pressure	Med-High Fire (119,000 BTU/HR Input) Temp Rise vs. External Static pressure (in. WC.)						
	0.1	0.2	0.3	0.4	0.5	0.6	0.7
Low	81	82	84	86	87	91	95
ML	67	68	69	71	74	77	80
MH	56	58	60	62	64	67	69
High	48	49	51	53	55	57	61

Speed Tap\ Static Pressure	Med-Low Fire (105,000 BTU/HR Input) Temp Rise vs. External Static pressure (in. WC.)						
	0.1	0.2	0.3	0.4	0.5	0.6	0.7
Low	72	73	74	76	78	80	84
ML	59	60	61	63	65	68	71
MH	50	51	53	55	57	59	62
High	42	44	45	47	49	51	54

Speed Tap\ Static Pressure	Low Fire (84,000 BTU/HR Input) Temp Rise vs. External Static pressure (in. WC.)						
	0.1	0.2	0.3	0.4	0.5	0.6	0.7
Low	58	59	60	61	62	65	68
ML	48	48	49	51	53	55	57
MH	40	41	43	44	46	48	50
High	34	35	36	38	39	41	43



Recommended Operation Range

SEE NEXT PAGE FOR MORE DATA –

A/C Evaporator Coil Applications

Furnace Model Number	AC Tonnage	Line Set	Cond. Model Number	Coil Model Number	Capacity	EER	SEER	AHRI Reference Number
VL*-CBP	2	LS01E-30 LS01E-50	TC4B2421H	HE33636PA212	23000	12.20	14.00	9136135
				HE47636PA212	23000	12.20	14.50	9136136
		TC7B2421S	HE33636PA212	23600	12.50	15.00	9136145	
			HE47636PA212	23600	13.00	16.00	9136146	
	2.5	LS01E-30 LS01E-50	TC4B3021H	HE33636PA212	29400	11.70	14.00	9136137
				HE47636PA212	29400	12.20	14.50	9136138
		TC7B3021S	HE33636PA212	28000	12.50	15.00	9136147	
			HE47636PA212	28400	13.00	16.00	9136148	
	3	LS01E-30 LS01E-50	TC4B3621H	HE33636PA212	34400	11.70	14.00	9136139
				HE47636PA212	34600	12.20	14.50	9136140
		TC7B3621S	HE33636PA212	34800	12.20	15.00	9136149	
			HE47636PA212	36000	13.00	16.00	9136150	
	3.5	LS02E-30 LS02E-50	TC7B4221S	-	-	-	-	-
				HE50660PA212	41500	13.00	16.00	9136152
	4 ¹	LS02E-30 LS02E-50	TC4B4821H	-	-	-	-	-
				HE50660PA212	47500	12.20	14.50	9136144
		TC7B4821S	-	-	-	-	-	
			HE50660PA212	45500	12.50	15.00	9136154	

¹ Blower upgrade kit, S00S4141 required for 4 ton cooling.

A/C Evaporator Coil Applications

	Furnace Model Number	AC Tonnage	Line Set	Cond. Model Number	Coil Cabinet	Coil Model Number	Capacity	EER	SEER	AHRI Reference Number
	C O U N T E R F L O W	VC-CBP	2	LS01E-30 LS01E-50	TC4B2421H	-	HE33636UA170	23000	12.20	14.00
-						HE47636UA205	23000	12.20	14.50	9136136
TC7B2421S				-	HE33636UA170	23600	12.50	15.00	9136145	
				-	HE47636UA205	23600	13.00	16.00	9136146	
2.5			LS01E-30 LS01E-50	TC4B3021H	-	HE33636UA170	29400	11.70	14.00	9136137
					-	HE47636UA205	29400	12.20	14.50	9136138
			TC7B3021S	-	HE33636UA170	28000	12.50	15.00	9136147	
				-	HE47636UA205	28400	13.00	16.00	9136148	
3			LS01E-30 LS01E-50	TC4B3621H	-	HE33636UA170	34400	11.70	14.00	9136139
					-	HE47636UA205	34600	12.20	14.50	9136140
			TC7B3621S	-	HE33636UA170	34800	12.20	15.00	9136149	
				-	HE47636UA205	36000	13.00	16.00	9136150	
3.5		LS02E-30 LS02E-50	TC7B4221S	-	-	-	-	-	-	
				-	HE50660UA205	41500	13.00	16.00	9136152	
4		LS02E-30 LS02E-50	TC4B4821H	-	-	-	-	-	-	
				-	HE50660UA205	47500	12.20	14.50	9136144	
		TC7B4821S	-	-	-	-	-	-		
			-	HE50660UA205	45500	12.50	15.00	9136154		