

TECHNICAL SPECIFICATIONS FOR MODEL VZ

COMMERCIAL/INDUSTRIAL GAS-FIRED LOW-INTENSITY RADIANT TUBE HEATER

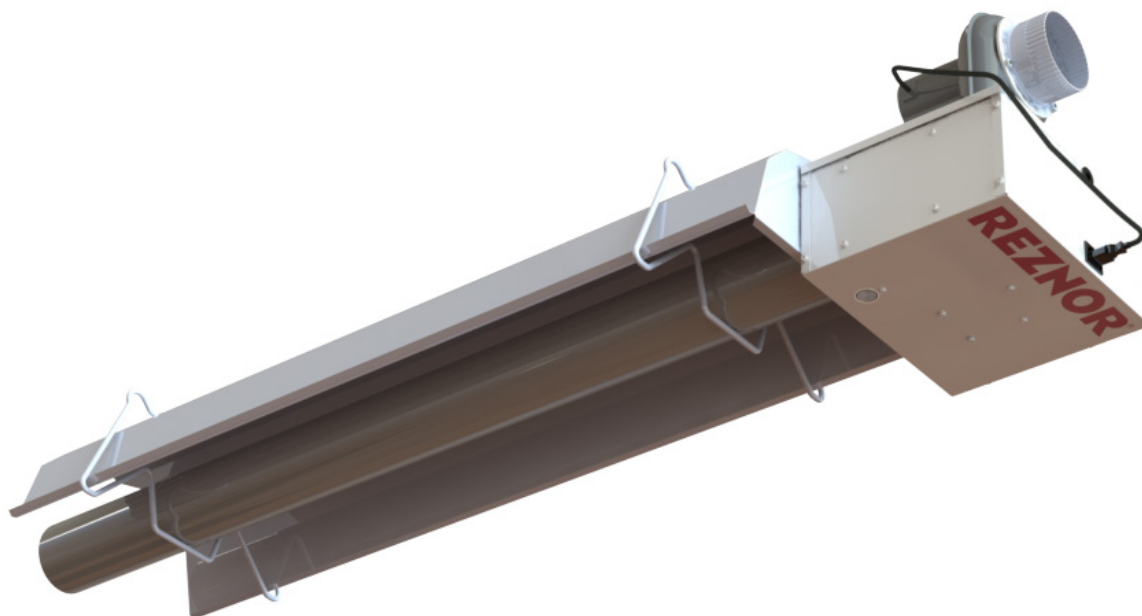

Table of Contents

Unit Sizes	2
Features	2
Factory-Installed Options	2
Field-Installed Options	2
Technical Data	3
Certification	3
Installation Codes	3
Heater Location	4
Mounting Height Requirements	4
Halogenated Hydrocarbons	4
Dimensions	4
Clearances	5
Weights	8
Venting Requirements	8
Combustion Air Requirements	8
Gas Supply Pressure	8
Gas Supply Piping	9
Wiring Requirements	9

In keeping with our policy of continuous product improvement, we reserve the right to alter, at any time, the design, construction, dimensions, weights, etc., of equipment information shown here.

TECHNICAL SPECIFICATIONS—CONTINUED

Unit Sizes

These heaters are available in ten unit sizes based on 40,000–200,000 BTUh input.

Features

- Voltage/phase/Hz: 120/1/60
- Natural gas or propane (unit size 200 available for natural gas only)
- Painted galvanized-steel burner cabinet with external blower and motor assembly
- 10-foot × 4-inch radiant tube sections of 16-gauge hot-rolled steel or heat-treated aluminized-steel
- U-tube and L-tube sections available for multiple configurations
- Aluminum reflectors
- Reflectors may be suspended level or angled at a 45-degree tilt
- Direct-spark ignition control system
- Single-stage combination gas valve
- Vertical or horizontal venting

Factory-Installed Options

Option	Description
AA1	Natural gas
AA2	Propane

Field-Installed Options

Systems are shipped disassembled and are comprised of a burner cabinet and a tube assembly along with any ordered field-installed option.

Option	Description
CC1	Vent cap, 4- or 6-inch
CC17	Vent terminal, 4-inch, Tjernlund
CC26	Vent terminal kit
CD28	Reflector side extension kit
CK53	Steel hanger kit
CK54	Stainless steel hanger kit
CK55	Steel turnbuckle kit
CK56	Stainless steel turnbuckle kit
CL1	Thermostat, 24V, single-stage, 50–90°F
CL5C	Thermostat, single-stage, line voltage, 120V/240V
CL65	Thermostat, analog, 120V, NEMA 4X moisture-resistant
CM1	Thermostat guard with locking cover
DE1	Outside combustion air kit, with steel hardware
DE2	Outside combustion air kit, with stainless steel hardware
DJ20	High-elevation conversion kit
DL2	Propane conversion kit
DN7	Protective grille kit
DO3	Protective (lower clearance) shield kit
IRT1	Transformer relay for multiple unit control

Technical Data

Parameter	Unit of Measure	Unit Size (MBTUh)									
		40	60	80	100	115	125	140	150	175	200
Heating capacity	BTUh	40,000	60,000	80,000	100,000	115,000	125,000	140,000	150,000	175,000	200,000
	kW	11.7	17.6	23.4	29.3	33.7	36.6	41.0	44.0	51.3	58.6

Parameter	Unit of Measure	Unit Size (MBTUh)		
		40, 60, 80, 100, 115, 125, 140, 150	175	200
Minimum gas supply pressure, natural gas	IN WC	4.6	5.0	
Maximum gas supply pressure, natural gas		14.0		
Required manifold (outlet) gas pressure, natural gas		3.5		
Minimum gas supply pressure, propane		11.0	—	
Maximum gas supply pressure, propane		14.0		
Required manifold (outlet) gas pressure, propane		10.5		
Maximum allowable pressure drop with flexible gas connector		0.50		
Full load amps	amp	1.0		
Gas connection	inch	1/2		
Combustion air inlet		4		
Vent connection				

Certification

These heaters are listed to ANSI Z83.20/CSA 2.34, 2.17, 2.20 for indoor use only in the US and Canada by the Canadian Standards Association (CSA). They are not approved for residential dwellings. They are approved without modification for installation elevations up to 2,000 feet (610 meters) in the US and up to 4,500 feet (1,370 meters) in Canada. A high-elevation conversion kit is available for higher installation elevations.

Installation Codes

- These units must be installed in accordance with local building codes. In the absence of local codes, in the United States, the unit must be installed in accordance with the *National Fuel Gas Code* (NFPA 54/ANSI Z223.1, latest edition). A Canadian installation must be in accordance with the *Natural Gas and Propane Installation Code* (CSA B149, latest edition). This code is available from CSA Information Services, 1-800-463-6727. Local authorities having jurisdiction should be consulted before installation is made to verify local codes and installation procedure requirements.
- Installations in aircraft hangars should be in accordance with the *Standard for Aircraft Hangars* (ANSI/NFPA 409, latest edition). Installations in public garages should be in accordance with the *Standard for Parking Structures* (ANSI/NFPA 88A, latest edition). Installations in repair garages should be in accordance with the *Standard for Repair Garages* (NFPA 88B), which has been incorporated into the *Code for Motor Fuel Dispensing Facilities and Repair Garages* (NFPA 30A, latest edition). In Canada, installations in aircraft hangars and public garages should be in accordance with CSA B149.
- If the heater is being installed in the Commonwealth of Massachusetts, installation must be performed by a licensed plumber or licensed gas fitter.

TECHNICAL SPECIFICATIONS—CONTINUED

Heater Location

⚠ CAUTION ⚠

- Heaters should not be used in an application where the heated space temperature is below 40°F (4°C). Operating under low ambient conditions may cause condensation to form in the heat exchanger.
- Do not locate the heater where it may be exposed to water spray, rain, or dripping water.

NOTE: The heater must be installed in a location that it is readily accessible for servicing.

Mounting Height Requirements

⚠ WARNING ⚠

The vent pipe and internal heater surfaces that are accessible from outside the heater may cause burns if touched. Suspend the heater a minimum of 8 feet (2.4 meters) above the floor.

NOTE: Suspended heaters are most effective when located as close to the working zone as possible, and this fact should be kept in mind when determining the mounting heights to be used.

Intended Heating Type	Unit Size (MBTUh)							
	40	60	80	100	115, 125	140, 150	175	200
	Feet (Meters)							
Space	8–10 (2.4–3)	10–12 (3–3.6)	12–15 (3.6–4.5)		15–20 (4.5–6)	20–25 (6–7.6)	25 (7.6)	
Spot	8 (2.4)	9 (2.7)	11 (3.3)	12 (3.7)	15 (4.6)	20 (6.1)	23 (7)	25 (7.6)

Halogenated Hydrocarbons

Halogenated hydrocarbons are a family of chemical compounds characterized by the presence of halogen elements (fluorine, chlorine, bromine, etc.). These compounds are used in refrigerants, cleaning agents, and solvents and are heavier than air, a fact that should be kept in mind when determining the installation location of heaters and building exhaust systems.

⚠ CAUTION ⚠

CORROSION HAZARD: Halogenated hydrocarbons, when exposed to flame, precipitate with any condensation present in the heater to form hydrochloric acid, which readily attacks all metals, including 300 grade stainless steel. Care should be taken to separate these vapors from the combustion process. An outside air supply **MUST BE** provided to the burner whenever the presence of these compounds is suspected.

Dimensions

Component	Unit of Measure	Unit Size (MBTUh)				
		40	60, 80	100, 115, 125	140, 150, 175	200
Minimum straight tube length	foot (meter)	10 (3)	20 (6.1)	30 (9.1)	40 (12.1)	50 (15.2)
Minimum U-tube length	foot, inch	—	11, 7	16, 7	21, 7	31, 7
	meter, cm		3, 54	5, 6	6, 58	9, 63
Reflector width	inch (cm)	14-3/16 (36)				
U-tube width with reflectors		32-3/16 (82)				

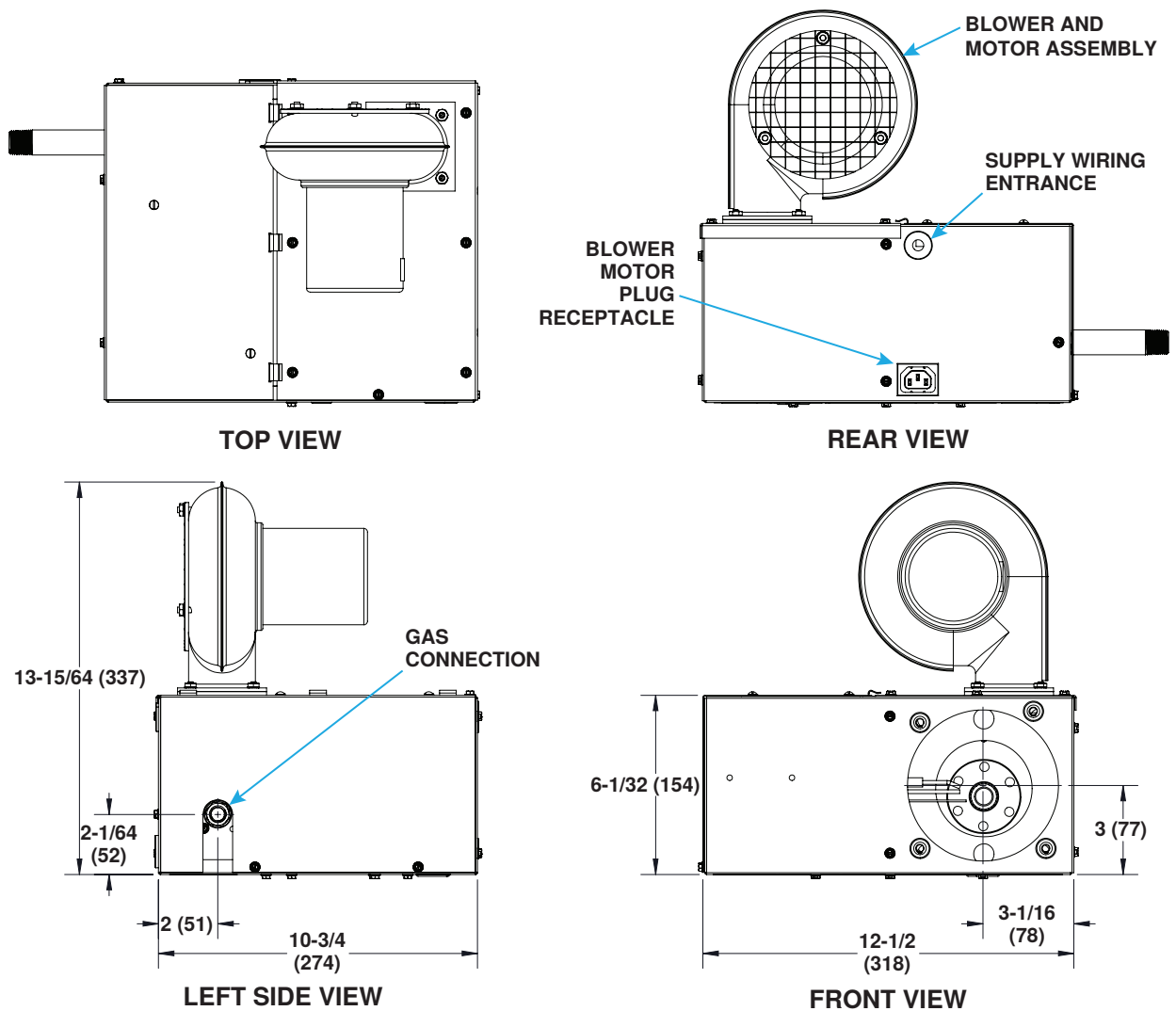

Clearances

⚠ DANGER ⚠

- All listed minimum clearances to combustibles **MUST BE** adhered to at all times. Adequate clearance **MUST BE** provided around air openings into the combustion chamber, and there **MUST BE** suitable clearance for service accessibility and for combustion/ventilation air.
- Minimum clearance from the heater must be maintained from vehicles parked below heater and from heat-sensitive equipment and workstations. In all situations, clearances to combustibles must be maintained. Signs should be posted in storage areas to specify maximum stacking height to maintain required clearance to combustibles. Such signs must either be posted adjacent to the heater thermostats or—in the absence of such thermostats—in a conspicuous location.

⚠ CAUTION ⚠

Building materials that have a low heat tolerance (plastics, vinyl siding, canvas, tri-ply, etc.) may be subject to degradation at lower temperatures. It is the installer's responsibility to ensure that adjacent materials are protected from degradation.

Clearance to combustibles is defined as the minimum distance from the heater to a surface or object for which it is necessary to ensure that a surface temperature of 90°F (50°C) above the surrounding ambient temperature is not exceeded. Units must be installed so that clearances are as follows:

TECHNICAL SPECIFICATIONS—CONTINUED

Clearances—Continued

Configuration (See Graphic Below)	Clearance*	Unit Size (MBTUh)							
		40	60	80	100	115, 125	140, 150	175	200
		Distance from Tube (Inches (cm))							
A. Straight tube with level reflector	Bottom	52 (133)	62 (158)	65 (166)	70 (178)	76 (194)	79 (201)	82 (209)	96 (244)
	Top	6 (16)						8 (21)	
	Sides	27 (69)	35 (89)	38 (97)	40 (102)	46 (117)	50 (127)	52 (133)	
B. Straight tube with level reflector and one extension reflector	Bottom	52 (133)	62 (158)	69 (176)	76 (194)	82 (209)	85 (216)	88 (224)	102 (260)
	Top	6 (16)						8 (21)	
	Extension reflector side	9 (23)							18 (46)
	Side opposite extension reflector	44 (112)	47 (120)	54 (138)	59 (150)	65 (166)	69 (176)	73 (186)	
C. Straight tube with level reflector and two extension reflectors	Bottom	52 (133)	65 (166)	71 (181)	77 (196)	83 (211)	87 (221)	91 (232)	102 (260)
	Top	6 (16)						8 (21)	
	Sides	15 (39)	23 (59)	25 (64)	27 (69)	32 (82)	35 (89)	40 (102)	
D. Straight tube with angled reflector	Bottom	50 (127)	59 (150)	65 (166)	73 (186)	77 (196)	83 (211)	85 (216)	85 (216)
	Top	8 (21)			10 (26)		12 (31)		
	Burner side	46 (117)	54 (138)	60 (153)	64 (163)	69 (176)	74 (188)	79 (201)	
	Side opposite burner	8 (21)							10 (26)
E. Straight tube with level reflector and optional protective grille	Bottom	52 (133)	62 (158)	65 (166)	70 (178)	76 (194)	79 (201)	82 (209)	96 (244)
	Top	6 (16)						8 (21)	
	Sides	27 (69)	35 (89)	38 (97)	40 (102)	46 (117)	50 (127)	52 (133)	
F. Straight tube with level reflector and optional protective shield**	Bottom	27 (69)	33 (84)	38 (97)	44 (112)	48 (122)	50 (127)	—	
	Top	6 (16)							
G. U-tube with level reflectors	Bottom	—	62 (158)	68 (173)	75 (191)	78 (199)	83 (211)	87 (221)	102 (260)
	Top	—	6 (16)					8 (21)	
	Burner side	—	35 (89)	38 (97)	40 (102)	46 (117)	50 (127)	54 (138)	
	Side opposite burner	—	30 (77)	37 (94)	39 (100)	43 (110)	47 (120)	51 (130)	51 (130)
H. Angled U-tube with level reflectors	Bottom	—	59 (150)	65 (166)	73 (186)	77 (196)	83 (211)	85 (216)	85 (216)
	Top and burner side	—	8 (21)						
	Side opposite burner	—	42 (107)	46 (117)	52 (133)	61 (155)	66 (168)	70 (178)	
J. U-tube with reflectors angled in opposite directions	Bottom	—	59 (150)	65 (166)	73 (186)	77 (196)	83 (211)	85 (216)	85 (216)
	Top	—	8 (21)		10 (26)		12 (31)		
	Burner side	—	54 (138)	60 (153)	64 (163)	70 (178)	74 (188)	76 (194)	
	Side opposite burner	—	22 (56)						
K. Unvented heater	Tube side	14 (36)		20 (51)					
	Tube end	18 (46)		24 (61)			30 (77)		30 (77)
K. Vented heater	Around vent pipe	18 (46)						18 (46)	

*Bottom and side clearances can be reduced by 50% at a point 25 feet (7.5 meters) downstream from burner.

**Clearances listed apply to when the protective shield is installed on the first 10 feet (3 meters) of tube extending from the burner cabinet. The bottom clearances from that point are the same as those for a straight tube with a level reflector (configuration A). The protective shield is not available for unit sizes 175 and 200.

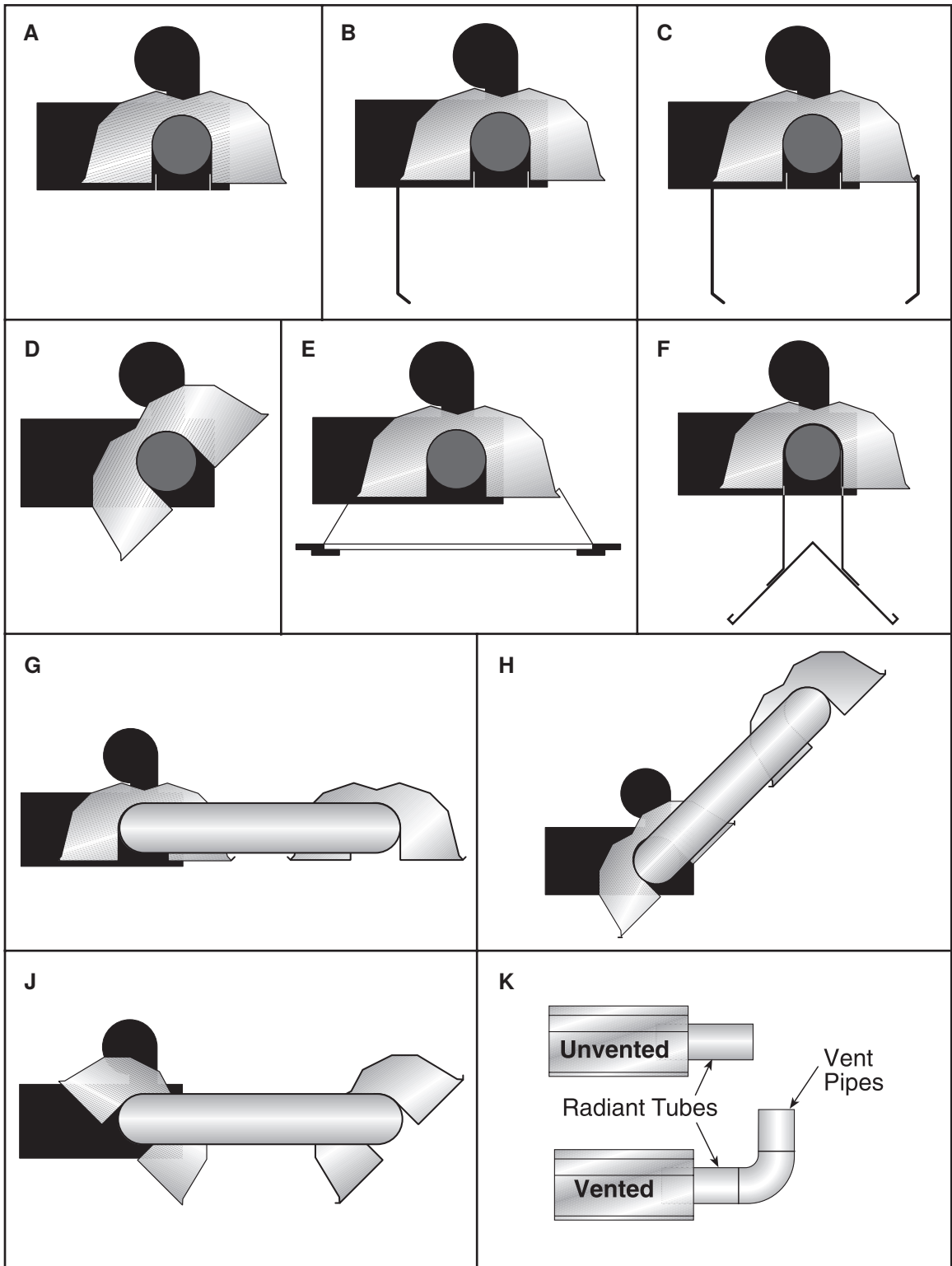

TECHNICAL SPECIFICATIONS—CONTINUED

Weights

Component	Tube Assembly Length (Feet)						
	10	20	30	40	50	60	70
	Pounds (kg)						
Straight tube assembly with aluminum reflectors*	52 (24)	86 (39)	120 (55)	161 (73)	206 (94)	240 (109)	281 (128)
Straight tube assembly with SST reflectors*	66 (30)	113 (53)	152 (69)	208 (95)	265 (121)	304 (138)	360 (164)
U-tube with aluminum reflectors	19 (8.7)						
U-tube with SST reflectors	20 (9.1)						
L-tube (90-degree elbow)	5.5 (2.5)						
Burner cabinet	18 (8.2)						

*Package includes reflectors, brackets, and hardware.

Venting Requirements

- The heater must be vented in accordance with the installation, operation, and maintenance manual provided with the unit and with the *National Fuel Gas Code* (NFPA 54/ANSI Z223.1, latest revision) in the US, with the *Natural Gas and Propane Installation Code* (CSA B149.1, latest revision) in Canada, and with any state, provincial, or local codes that may apply. Any portion of vent pipe passing through a combustible wall must have an approved thimble to conform with these codes.
- The heater may be individually vented or common vented. When venting vertically, a maximum of four heaters can be commonly vented. When venting horizontally, a maximum of two heaters can be commonly vented.
- All joints must be secured using #8 × 3/8 sheet metal screws and sealed using high-temperature (≥550°F (≥288°C)) silicone sealant.

Combustion Air Requirements

⚠ CAUTION ⚠

- **IMPORTANT:** If the building has a slight negative pressure or if corrosive contaminants such as halogenated hydrocarbons are present in the air, an outside supply of combustion air to the heater is required.
- Seal all combustion air pipe joints.
- The use of optional outside combustion air is not recommended with unvented heaters.
- The air supply duct may have to be insulated to prevent condensation on the outer surface.

NOTE: Heaters with a common combustion air pipe must be controlled by a common thermostat.

Gas Supply Pressure

- The unit is equipped for a maximum gas supply pressure of 1/2 psi, 3.5 kPa, or 14 IN WC for natural gas or propane. The minimum supply pressure, as measured while the unit is operating at full fire, is 4.6 IN WC (unit sizes 40-150) or 5 IN WC (unit sizes 175 and 200) for natural gas or 11 IN WC for propane.
- Supply pressure higher than 1/2 psi requires the installation of an additional service regulator external to the unit.
- **Pressure testing supply piping:** For test pressures *above* 1/2 psi, disconnect the heater and manual valve from the gas supply line to be tested and cap or plug the supply line. For test pressures *below* 1/2 psi, before testing, close the manual valve on the heater.

Gas Supply Piping

- All piping must be in accordance with requirements outlined in the *National Fuel Gas Code* (NFPA 54/ANSI Z223.1, latest edition) or the *Natural Gas and Propane Installation Code* (CSA B149.1, latest edition).
- Variables for sizing gas supply lines are listed in the table below. When sizing supply lines, consider the possibility of future expansion and increased requirements (refer to the *National Fuel Gas Code* for additional information).

Pipe Length (Feet)	Natural Gas						Propane					
	Pipe Diameter (Inches)											
	1/2	3/4	1	1-1/4	1-1/2	2	1/2	3/4	1	1-1/4	1-1/2	1-1/2
	Cubic Feet per Hour											
20	92	190	350	730	1100	2100	56	116	214	445	671	1281
30	73	152	285	590	890	1650	45	93	174	360	543	1007
40	63	130	245	500	760	1450	38	79	149	305	464	885
50	56	115	215	440	670	1270	34	70	131	268	409	775
60	50	105	195	400	610	1105	31	64	119	244	372	674
70	46	96	180	370	560	1050	28	59	110	226	342	641
80	43	90	170	350	530	990	26	55	104	214	323	604
90	40	84	160	320	490	930	24	51	98	195	299	567
100	38	79	150	305	460	870	23	48	92	186	281	531
125	34	72	130	275	410	780	21	44	79	168	250	476
150	31	64	120	250	380	710	19	39	73	153	232	433
175	28	59	110	225	350	650	17	36	67	137	214	397
200	26	55	100	210	320	610	16	34	61	128	195	372

Wiring Requirements

⚠ DANGER ⚠

- **Electrical shock can cause personal injury or death. Before making electrical connections, switch OFF the main electrical disconnect. There may be more than one disconnect switch. Lock out and tag the switch(es) using a suitable warning label.**
- **This appliance must be electrically grounded.**
- **120VAC supply is present at each burner when the thermostat is switched OFF. When servicing the heater, ensure that the electric supply is isolated from the mains supply.**

⚠ CAUTION ⚠

- **Ensure that all wiring is in accordance with the wiring diagram provided with the unit.**
- **All electrical wiring and connections, including electrical grounding MUST BE made by a qualified electrician in strict accordance with the *National Electric Code* (ANSI/NFPA No. 70, latest edition) or, in Canada, the *Canadian Electric Code* (Part 1, CSA C.22.1). In addition, the installer should be aware of any local ordinances or gas company requirements that might apply.**
- **If any of the original wire supplied with the appliance must be replaced, it MUST BE replaced with wiring material having a temperature rating of at least 220°F (105°C) and 600V.**

⚠ DANGER ⚠

FIRE OR EXPLOSION HAZARD

- Failure to follow safety warnings exactly could result in serious injury, death, or property damage.
- Improper installation, adjustment, alteration, service, or maintenance can cause serious injury, death, or property damage.
- Installation and service must be performed by a qualified installer, service agency, or the gas supplier.
- Do not store or use gasoline or other flammable vapors and liquids in the vicinity of this or any other appliance.

WHAT TO DO IF YOU SMELL GAS

- Do not try to light any appliance.
- Do not touch any electrical switch; do not use any phone in your building.
- Leave the building immediately.
- Immediately call your gas supplier from a phone remote from the building. Follow the gas supplier's instructions.
- If you cannot reach your gas supplier, call the fire department.

For more information on Reznor HVAC products:

- Contact your local Reznor representative at 1-800-695-1901
- Refer to the manuals and additional consumer materials found at www.reznorhvac.com

