

USER'S MANUAL

DVUT 300 HB EC
DVUE 300 HB EC



Single-room heat recovery air handling unit

CONTENTS

Safety requirements	2
Purpose	4
Delivery set	4
Designation key	4
Technical data	5
Design and operating principle	6
Mounting and set-up	7
Connection to power mains.....	9
Control.....	11
Technical maintenance.....	11
Troubleshooting	13
Storage and transportation regulations	13
Manufacturer's warranty	14
Certificate of acceptance.....	15
Seller information.....	15
Installation certificate	15
Warranty card	15

This user's manual is a main operating document intended for technical, maintenance, and operating staff.

The manual contains information about purpose, technical details, operating principle, design, and installation of the DVUT/DVUE 300 HB EC unit and all its modifications.

Technical and maintenance staff must have theoretical and practical training in the field of ventilation systems and should be able to work in accordance with workplace safety rules as well as construction norms and standards applicable in the territory of the country.

SAFETY REQUIREMENTS

All user's manual requirements as well as the provisions of all the applicable local and national construction, electrical, and technical norms and standards must be observed when installing and operating the unit.

Disconnect the unit from the power supply prior to any connection, servicing, maintenance, and repair operations.

Only qualified electricians with a work permit for electrical units up to 1000 V are allowed for installation. The present user's manual should be carefully read before beginning works.

Check the unit for any visible damage of the impeller, the casing, and the grille before starting installation. The casing internals must be free of any foreign objects that can damage the impeller blades.

While mounting the unit, avoid compression of the casing! Deformation of the casing may result in motor jam and excessive noise.

Misuse of the unit and any unauthorised modifications are not allowed.

Do not expose the unit to adverse atmospheric agents (rain, sun, etc.).

Transported air must not contain any dust or other solid impurities, sticky substances, or fibrous materials.

Do not use the unit in a hazardous or explosive environment containing spirits, gasoline, insecticides, etc.

Do not close or block the intake or extract vents in order to ensure the efficient air flow.

Do not sit on the unit and do not put objects on it.

The information in this user's manual was correct at the time of the document's preparation. The Company reserves the right to modify the technical characteristics, design, or configuration of its products at any time in order to incorporate the latest technological developments. Never touch the unit with wet or damp hands. Never touch the unit when barefoot.

This unit is not intended for use by persons (including children) with reduced physical, sensory or mental capabilities, or lack of experience and knowledge, unless they have been given supervision or instruction concerning use of the unit by a person responsible for their safety. Children should be supervised to ensure that they do not play with the unit.

If the supply cord is damaged, it must be replaced by the manufacturer, its service agent, or similarly qualified persons in order to avoid a safety hazard.

Ensure that the unit is switched off from the supply mains before removing the guard.

Precautions must be taken to avoid the back-flow of gases into the room from the open flue of gas or other fuel-burning appliances.



**THE PRODUCT MUST BE DISPOSED SEPARATELY AT THE END OF ITS SERVICE LIFE.
DO NOT DISPOSE THE UNIT AS UNSORTED DOMESTIC WASTE.**

PURPOSE

The unit is designed to ensure continuous mechanical air exchange in houses, offices, hotels, cafes, conference halls, and other utility and public spaces as well as to recover the heat energy contained in the air extracted from the premises to warm up the filtered stream of intake air.

The unit is not intended for organizing ventilation in swimming pools, saunas, greenhouses, summer gardens, and other spaces with high humidity.

Due to the ability to save heating energy by means of energy recovery, the unit is an important element of energy-efficient premises.

The unit is a component part and is not designed for stand-alone operation. It is rated for continuous operation.

Transported air must not contain any flammable or explosive mixtures, evaporation of chemicals, sticky substances, fibrous materials, coarse dust, soot and oil particles or environments favourable for the formation of hazardous substances (toxic substances, dust, pathogenic germs).



THE UNIT SHOULD NOT BE OPERATED BY CHILDREN OR PERSONS WITH REDUCED PHYSICAL, MENTAL, OR SENSORY CAPACITIES, OR THOSE WITHOUT THE APPROPRIATE TRAINING.

THE UNIT MUST BE INSTALLED AND CONNECTED ONLY BY PROPERLY QUALIFIED PERSONNEL AFTER THE APPROPRIATE BRIEFING.

THE CHOICE OF UNIT INSTALLATION LOCATION MUST PREVENT UNAUTHORISED ACCESS BY UNATTENDED CHILDREN.



FOR RESIDENTIAL INSTALLATION ONLY

THE UNIT IS INTENDED ONLY FOR FREE-AIR DISCHARGE OR FOR CONNECTION TO A DUCT SUPPLYING ONLY ONE ROOM



NOT FOR OUTDOORS USE

DELIVERY SET

NAME	NUMBER
Air handling unit	1
User's manual	1
Control panel	1
Key to a service panel	1
Packing box	1

DESIGNATION KEY

Designation key example: **DVUT 300 HB EC A18-1**

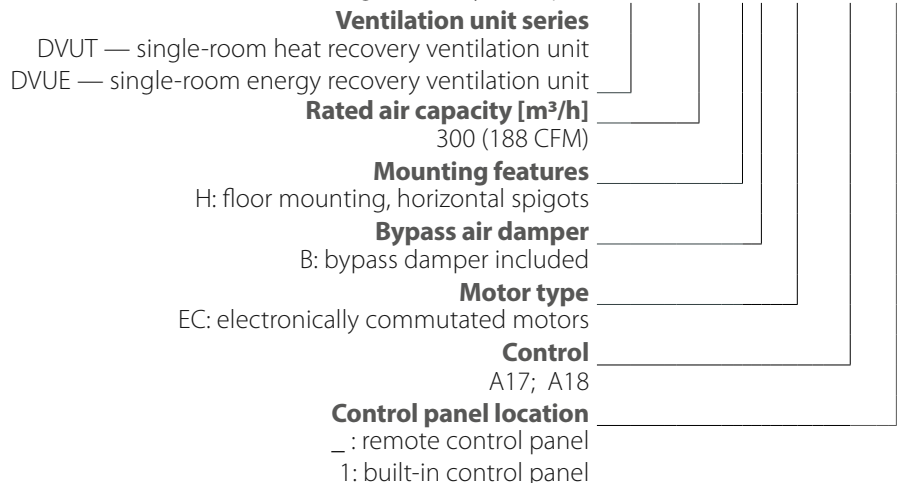

TECHNICAL DATA

The unit is designed for indoor application with the ambient temperature ranging from +33.8 °F to +104 °F and relative humidity up to 60 % without condensation. In cold, damp rooms, there is a possibility of freezing or condensation inside and outside the casing. In order to prevent condensation on the internal walls of the unit, it is necessary that the surface temperature of the casing is 35,6-37,4 °F above the dew point temperature of the transported air.

The unit should be operated continuously, and in cases where ventilation is not necessary, reduce the air flow of the fans to a minimum (20 %). This will ensure a favorable indoor climate and reduce the amount of condensation inside the unit, which can damage electronic components. Never use the unit for dehumidification, for example, of new buildings.

The unit is rated as a Class I electrical appliance.

Hazardous parts access and water ingress protection rating:

IP20 for the unit connected to the air ducts.

IP44 for the unit motors.

The unit design is constantly being improved, thus some models may be slightly different from those described in this manual.

UNIT OVERALL DIMENSIONS [Inch]

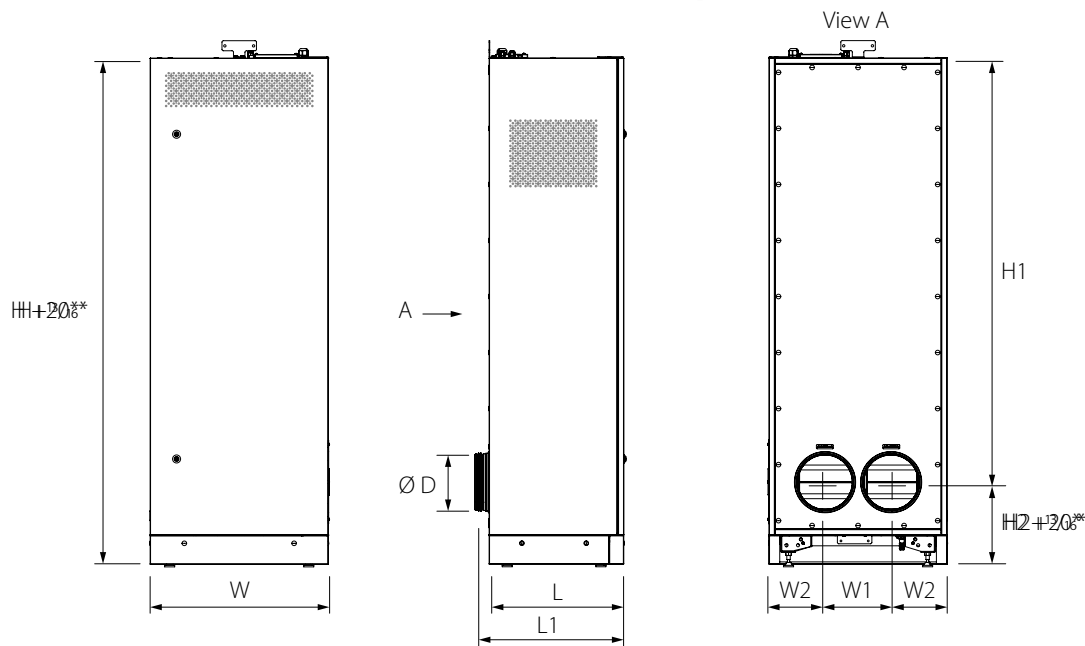

Model	D	W	W1	W2	L	L1	H	H1	H2
DVUT(E) 300 HB EC	7 7/8"	24 7/16"	9 1/16"	7 11/16"	18 1/2"	20 1/2"	69 11/16"	58 1/8"	11 9/16"

*The unit height may be adjusted by means of leveling feet.

Model	DVUT 300 HB EC	DVUE 300 HB EC
Power supply voltage, 60 Hz [V]	1~120	
Unit power consumption excl. electric heater [W]	132	
Maximum unit current [A]	1,8	
Maximum air flow [m³/h]	188	
Noise level, 3 m [Sones]	1.9	
Transported air temperature [°F]	-13 ... +104	
Casing material	painted steel	
Insulation	1 9/16 inch mineral wool	
Extract filter	MERV 6 x 2	
Supply filter	MERV 6 + MERV 14	
Optional supply filter	H11 + MERV 14	
Connected duct diameter [inch]	7 7/8"	
Weight [lbs]	304±3%	300±3%
Heat recovery efficiency [%]	78-92	73-89
Heat exchanger type	counter-flow	
Heat exchanger material	polystyrene	enthalpy
SEC class	A	

DESIGN AND OPERATING PRINCIPLE

The unit operation is as follows:

Warm extract air from the room flows into the unit and is cleaned in the extract filters. Then the air is moved through the heat exchanger and is exhausted outside through the air ducts with the extract fan. Cold fresh air from outside flows into the unit, where it is cleaned with the supply filters. Then the air flows through the heat exchanger and is moved to the room with the supply fan. Supply air is heated in the heat exchanger by transferring the heat energy of warm and humid extract air to the cold fresh air. The air flows are fully separated while flowing through the heat exchanger. Heat recovery minimizes heat losses, which reduces the cost of space heating in the cold season.

UNIT OPERATING PRINCIPLE

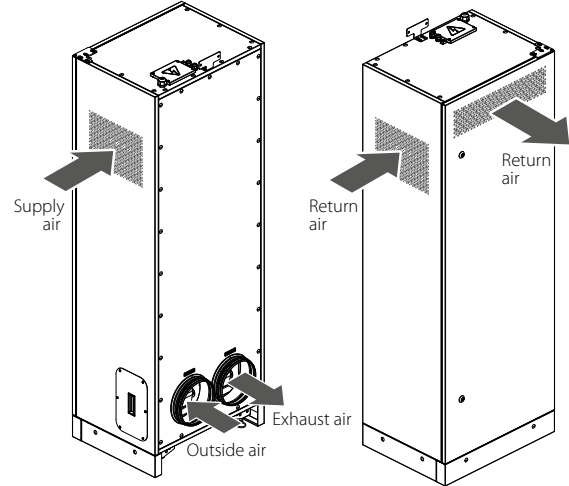

The unit is a frame structure made of rigidly fixed steel panels. The panels are made of painted steel sheets and a galvanized steel sheet with a layer of mineral wool between for heat- and sound-insulation.

The service door enables access for maintenance and service operations.

The power cables and grounding conductors must be routed through the cable glands to the terminal block located on the top casing panel.

The wiring diagram for wiring of the air handling unit is shown on the inner side of the terminal box lid.

The unit design enables installation of a bypass duct with a bypass damper to route the intake air stream without contacting the heat exchanger.

To protect the heat exchanger from freezing in the cold season, the unit has a Frost Protection mode.

If there is a risk of freezing, the supply fan is switched off.

After temperature increase the unit returns to the previous operation mode.

The supply and extract air temperature difference during heat recovery may lead to condensate formation in the units with a polystyrene heat exchanger. The condensate is collected in the drain pan and is removed outside to the exhaust air duct through the drain hose. No condensate is generated in the units with an enthalpy heat exchanger as the air moisture is transferred from one air stream to the other via the membrane.

UNIT DESIGN

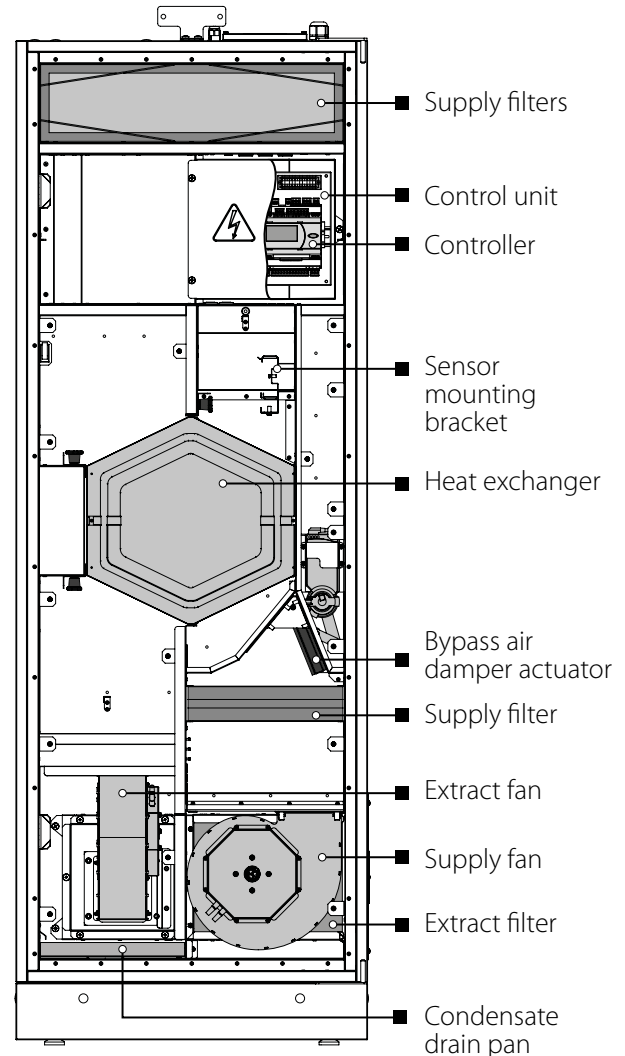

Additional equipment (available on a separate order)

- Humidity sensor. The unit with an installed humidity sensor maintains a set indoor humidity level. As the extract air humidity rises above the set point, the system automatically switches to the maximum speed. As the humidity drops down below the set point the unit returns to the previous mode.
- CO₂ sensor. Measures the level of concentration of carbon dioxide in the room and generates a signal that controls the performance of the fan. Air flow control based on CO₂ concentration is an efficient energy saving solution.

MOUNTING AND SET-UP



READ THE USER'S MANUAL BEFORE INSTALLING THE UNIT.

Sufficient service access to the unit for maintenance or repair operations must be provided.

The recommended minimum distances from the unit to the walls are shown below.

Make sure the unit has no foreign objects inside before starting it up.

The unit is designed for mounting to a horizontal surface adjacent to the wall with the ready-made holes for the air ducts.

The fixing brackets with a fastening hole enable fixation of the unit to the wall. The fixing brackets are not included in the delivery set.

The drain pan is equipped with two drain pipe for condensate removal outside the unit.

Connect the drain pipe, the U-trap or the U-trap (hydraulic seal) of the other type (not included in the standard delivery set) and the sewerage system with metal, plastic or rubber pipes.

While laying the connection pipes provide the slope of minimum 3° downwards.

Before starting operation, provide free drainage for the condensed water, otherwise it is accumulated inside the unit that may cause the equipment damage and condensate outflow to the room.

Fill up the U-trap with water before using it.

When using other hydraulic seal systems, carefully read the instructions for preparing the condensate drain system for operation.

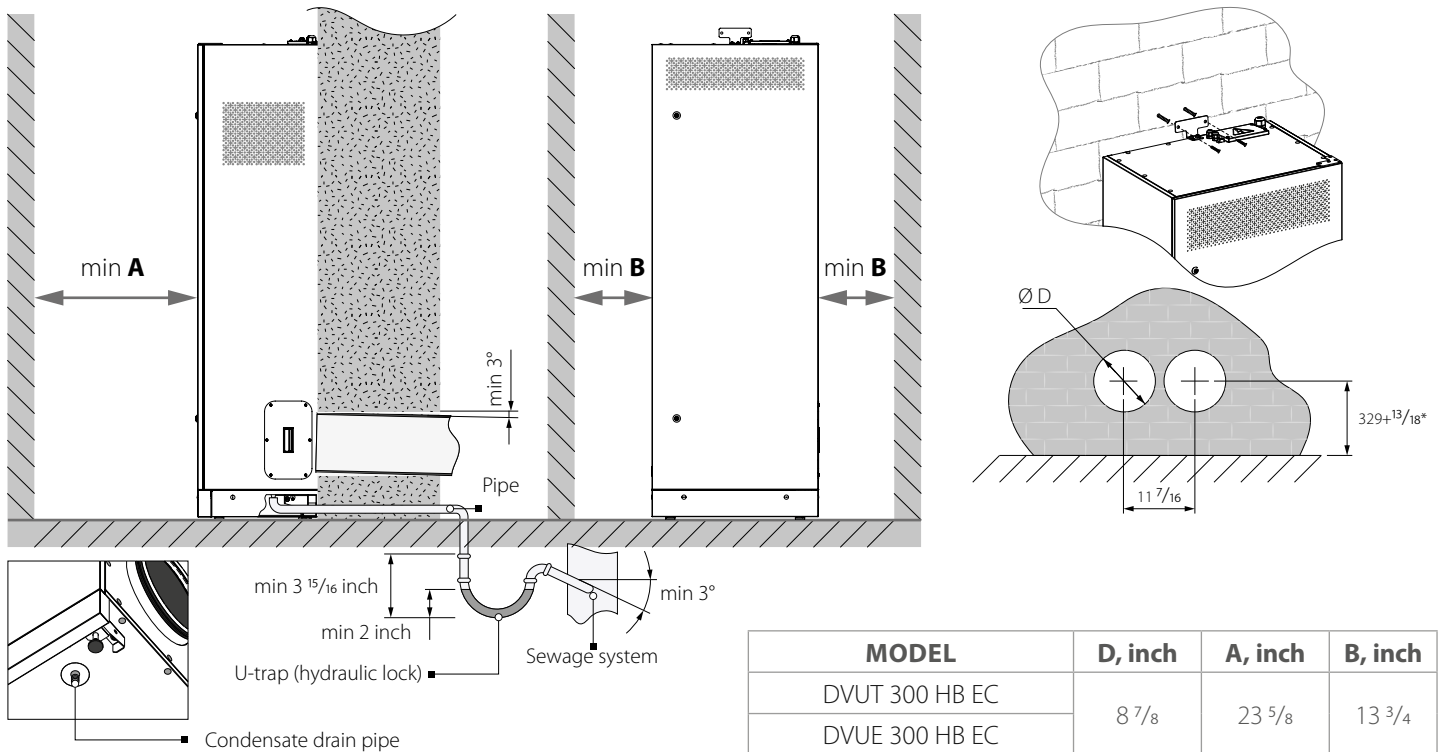

* the dimension may be increased during adjustment of the unit by means of the levelling feet

The leveling feet on the bottom of the unit ensure exact alignment of the unit during mounting.

For alignment of the unit loosen the nuts and adjust position of the support disc manually using a wrench. Then tighten the upper and the lower nut.

To attain the best performance of the unit and to minimize turbulence-induced air pressure losses while mounting, connect straight air duct sections to the unit spigots.

Minimum straight air duct length:
 equal to 1 air duct diameter on intake side
 equal to 3 air duct diameters on outlet side

If the air ducts are too short or not connected, protect the unit parts from ingress of foreign objects. To prevent uncontrollable access to the fan, the spigots may be covered with a protecting grille or other protecting device with mesh width not more than 1/2 inches.

Fasteners for the unit mounting are not included into delivery set and should be ordered separately.

While selecting appropriate fasteners consider material of the mounting surface as well as the weigh of the unit, refer to the technical data. For selection of the fasteners for unit mounting please refer to a service technician.

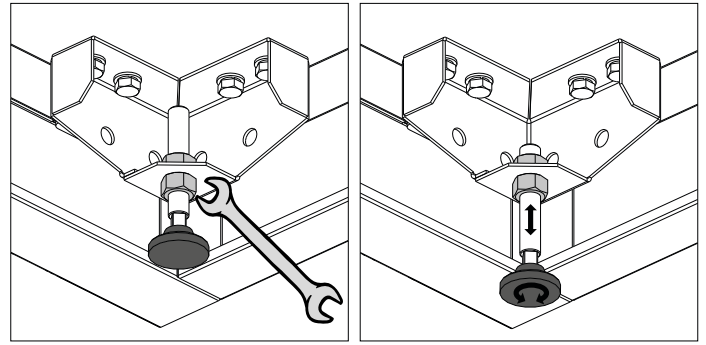

INSTALLATION AND CONNECTION OF SENSORS

The unit provides for the installation and connection of one of the sensors – an humidity sensor or a CO₂ sensor.

The sensors are not included in the delivery set and can be ordered separately.

Humidity sensor installation and connection

The humidity sensor must be attached inside of the extract air duct.

Attach the sensor to the insert. Open the unit, remove the upper part of the protective casing and install the insert with the sensor on the bracket located on the wall of the exhaust duct. Connect the sensor connector to the connector with the cable from the control unit (installed by the manufacturer).

After connecting the humidity sensor, it is necessary to change the control configuration in the controller. Contact the product Seller for doing that.

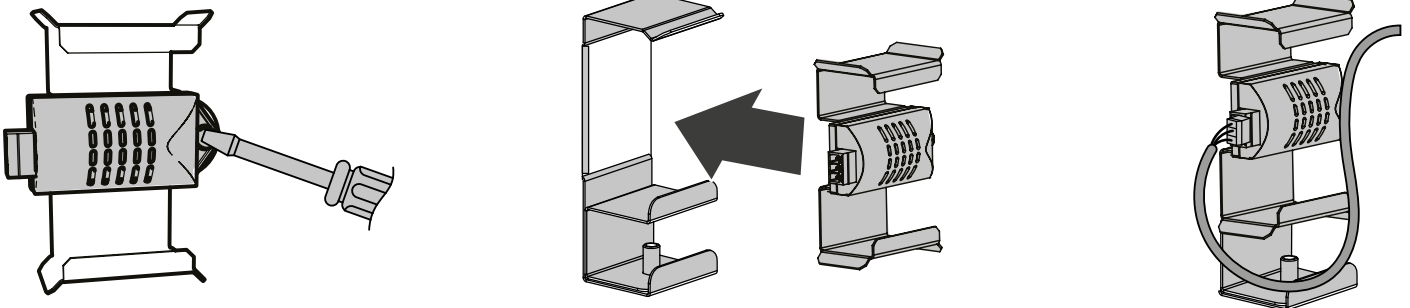

Humidity sensor wiring

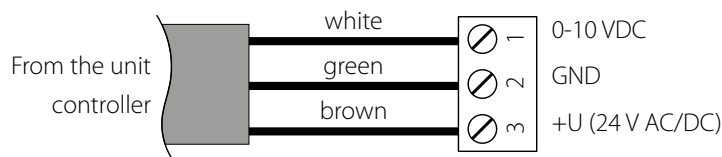

CO₂ sensor mounting and connection

The CO₂ sensor must be installed in the exhaust air duct upstream of the heat exchanger. Open the unit, remove the upper part of the protective cover. Using a screwdriver remove the screw on the bracket holding the insert. Then use a small screwdriver to disconnect the connector. Disassemble the CO₂ sensor in accordance with the instructions supplied with it and connect it in accordance with the provided diagram. Reassemble the sensor in the reverse order and install it on the bracket inside the unit.

Update the control configuration after connection of the humidity sensor. Contact the product Seller for doing that.

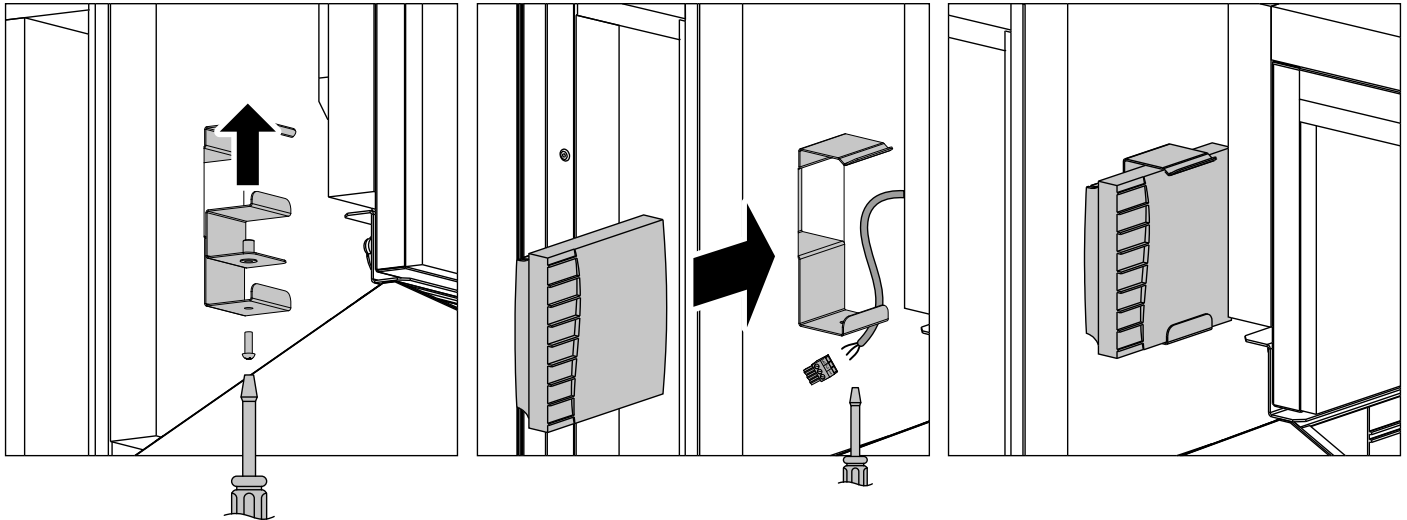

CO₂ sensor wiring

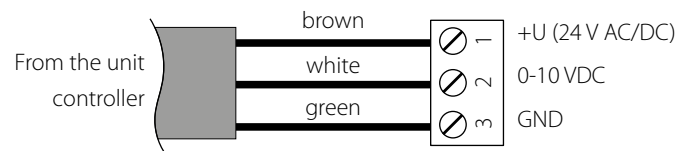

CONNECTION TO POWER MAINS



**POWER OFF THE POWER SUPPLY PRIOR TO ANY OPERATIONS WITH THE UNIT.
THE UNIT MUST BE CONNECTED TO POWER SUPPLY BY A QUALIFIED ELECTRICIAN.
THE RATED ELECTRICAL PARAMETERS OF THE UNIT ARE GIVEN ON THE
MANUFACTURER'S LABEL.**



**ANY TAMPERING WITH THE INTERNAL CONNECTIONS IS PROHIBITED
AND WILL VOID THE WARRANTY.**



USE COPPER CONDUCTORS ONLY

The unit is rated for connection to 1~120 V/60 Hz power mains.

The external power input must be equipped with an automatic circuit breaker built into the stationary wiring to open the electric circuit in case of overload or short-circuit. The circuit breaker installation place must provide quick access for emergency shutdown of the unit. The automatic circuit breaker rated current must exceed the ventilator current consumption, refer to the Technical data section.

It is recommended to select the nominal current of the circuit breaker from the standard series, following the maximum current of the connected unit. The circuit breaker is not included in the delivery set and can be ordered separately.

CONNECTION OF ADDITIONAL EXTERNAL CONTROLS

Connection of the external th-Tune control panel (A17)

To access the terminal block, unscrew the screws of the control unit cover and remove it.
Route the cables to the control unit through the sealed cable glands in the unit.
All the electric connections must be performed in compliance with the external wiring diagram and wired through the terminal block X1 in the control unit.

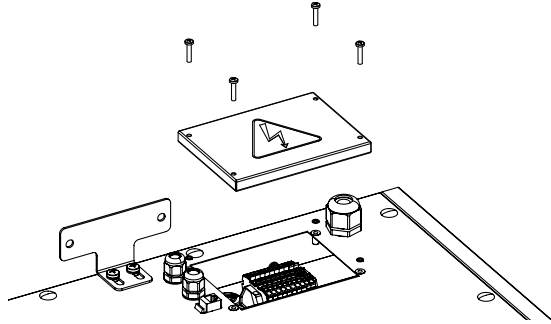

External wiring diagram of the th-Tune control panel

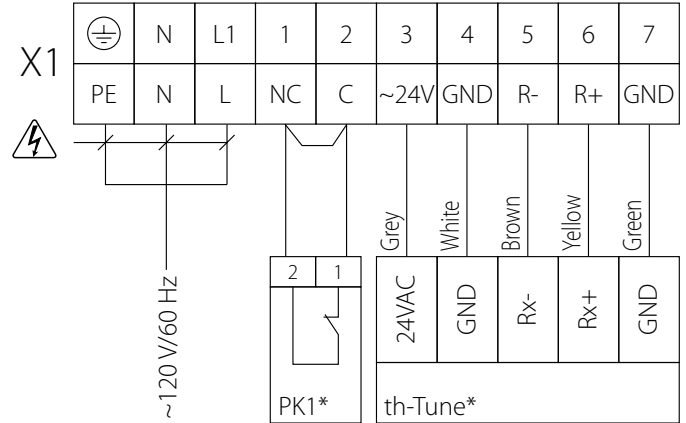

Designations	Name	Cable type	Maximum cable length	Note
PK1*	Fire alarm panel	NC	2xAWG20	Remove the jumper during connection
th-Tune*	Control panel	-	5xAWG22 (max. length up to 32 ft)	-
~120 V/60 Hz	Power input	-	3xAWG18(14)	-

*Additionally connected devices are not included in the delivery set, purchased separately.

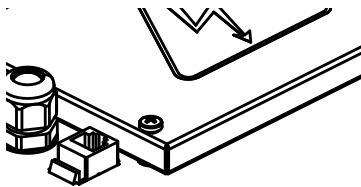

Connection of the external pGDE control panel (A18)

Connection of the pGDE control panel is carried out with the 6P6C* (PLUG-6P6C-P-C2) phone connector.
The connector is located on the top of the unit.

CONTROL

Depending on the model the unit can be controlled:

- via a built-in control panel A17/A18
- via a wired control panel A17/A18
- via a controller (located in the control unit)

The functions of the controller and the th-Tune and pGDE control panels are described in the respective user's manuals.

TECHNICAL MAINTENANCE



WARNING! ELECTRIC SHOCK HAZARD!
DISCONNECT THE UNIT FROM POWER SUPPLY BEFORE ANY MAINTENANCE OPERATIONS!

Maintenance operations of the unit are required 3-4 times per year. Maintenance includes general cleaning of the unit and the following operations:

1. Filter maintenance.

Clogged filters increase air resistance in the system and reduce supply air volume.

Clean the filters as required, but not less than 3-4 times per year.

Upon elapsing of the set time for filter replacement a signal for filter replacement or cleaning is generated. In this case clean or replace the filters and reset the operating hours.

The filter timer must be reset by a service engineer.

Filter cleaning with a vacuum cleaner is allowed.

After two consecutive cleanings the filters must be replaced.

For new filters of the type stated in the technical data, please contact to the unit Seller.

Steps for removal of the filters:

- Disconnect the unit from power supply.
- Open the service door using the key.
- Press slightly and release the retaining clips to remove the supply filters.
- Pull the filters to remove. Install the filters in the reverse order.

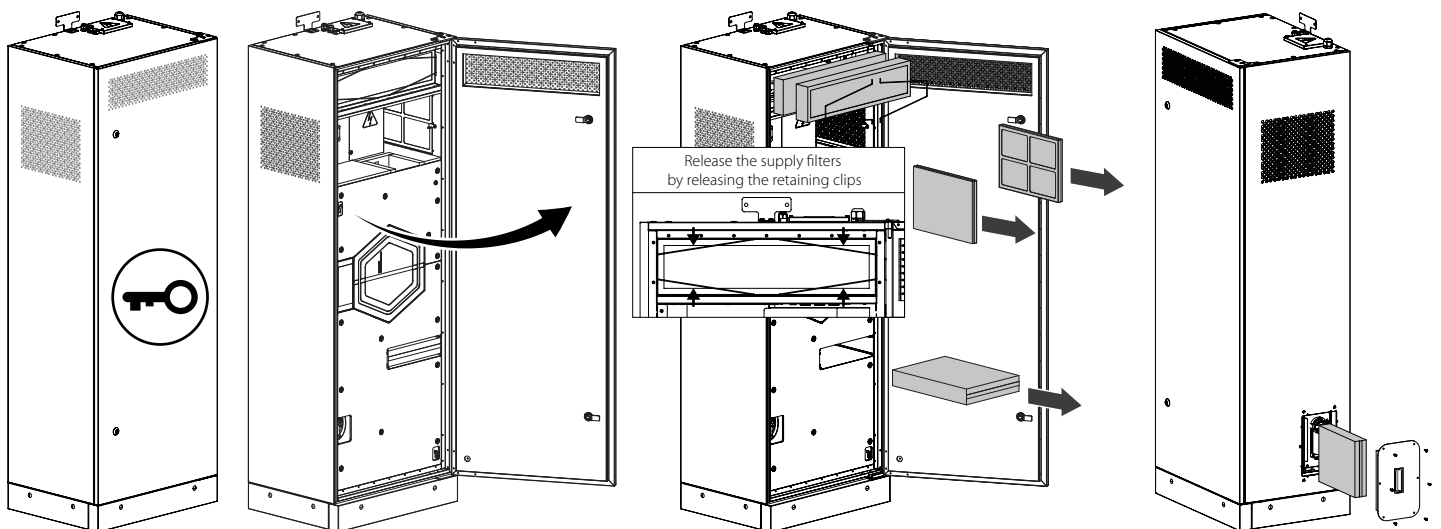

2. Heat exchanger maintenance (once per year).

Some dust may accumulate on the heat exchanger even in case of regular maintenance of the filters. Regular cleaning of the heat exchanger is required to maintain high heat recovery efficiency.

To clean the heat exchanger (**DVUE**), remove it from the unit and clean it with compressed air, a vacuum cleaner or rinse under low pressure with water.

To clean the polystyrene heat exchanger (**DVUT**), remove it from the unit and rinse it with warm water solution of neutral detergent. After cleaning and drying, install the heat exchanger back in place.

Steps for removal of the heat exchanger:

- Disconnect the unit from power supply.
- Open the service door using the key.
- Remove the 6 screws that retain the upper protective housing and take it off.
- Loosen the hand screws to release the heat exchanger, then pull the heat exchanger to remove.

After completion of maintenance install the heat exchanger in the reverse order.

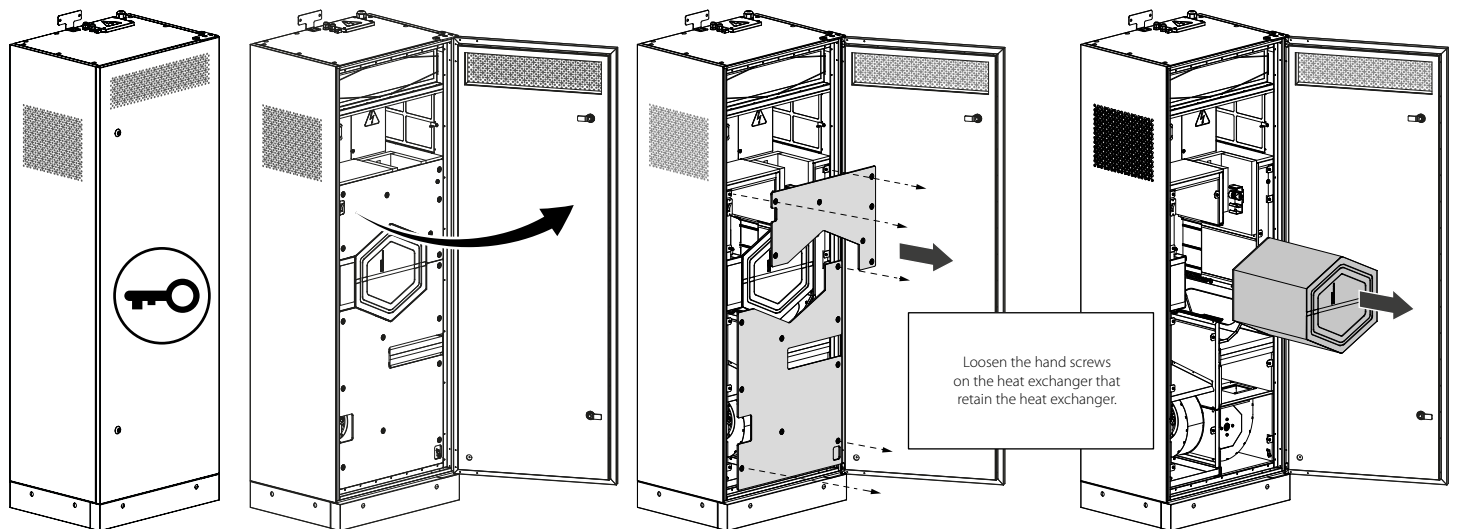

3. Fan maintenance (once a year).

Even in case of regular maintenance of the filters, some dust may accumulate inside the fans and reduce the fan performance and supply air flow. Clean the fans with a soft cloth, brush or compressed air.

Do not use water, aggressive solvents or sharp objects as they may damage the impeller.

4. Maintenance of air intake devices (twice per year).

The supply grille may get clogged with leaves and other objects, which reduces the unit performance and supply air delivery. Check the supply grille twice per year and clean it as required.

5. Air duct system maintenance (every 5 years).

Even regular fulfilling of all the maintenance operations described above may not completely prevent dust accumulation in the air ducts, which reduces the unit performance. Duct maintenance means regular cleaning or replacement.

6. Control unit maintenance (as required).

The control unit is located inside of the unit casing. For accessing the control unit remove the fixing screws on the panel and remove the control unit lid.

TROUBLESHOOTING

TROUBLE	POSSIBLE REASONS	TROUBLESHOOTING
The fan(s) do(es) not get started during activation of the unit.	No power supply.	Make sure the power supply line is connected correct. Otherwise troubleshoot a connection error.
	Motor or impeller clogging.	Turn the unit off. Troubleshoot the fan clogging. Clean the blades. Restart the unit.
	System failure.	Turn the unit off. Contact the product Seller.
Automatic circuit breaker tripping after the unit start-up.	Overcurrent as a result of short circuit in the electric circuit.	Turn the unit off. Contact the product Seller.
Low air flow.	Low set fan speed.	Set higher speed.
	Clogged filters, fans or heat exchanger.	Clean or replace the filters. Clean the fans and the heat exchanger.
	Clogged or damaged air ducts, diffusers, louver shutters, grilles or other ventilation system components.	Clean or replace the air ducts, diffusers, louver shutters, grilles or other ventilation system components.
Low supply air temperature.	Clogged extract filter.	Clean or replace the extract filter.
Noise, vibration.	The impeller(s) is soiled.	Clean the impeller(s).
	The fan or casing screw connection is loose.	Tighten the screw connection of the fans or the casing all the way.
	No anti-vibration connectors on air duct pipe flanges.	Install anti-vibration connectors.
The alarm indicator glows on the control panel.	Communication loss (cable or wire breakdown) between the control panel and the ventilation unit.	Check the power and connection cables and wires between the control panel and the air handling unit for integrity using a multimeter. If unassisted troubleshooting fails, please contact the product Seller.
	Wrong cable installation.	Make sure the cable installation is completed according to the requirements stated in the user's manual for the control panel. Otherwise install the cable as required.
	System failure.	Contact the product Seller.

STORAGE AND TRANSPORTATION REGULATIONS

- Store the unit in the manufacturer's original packaging box in a dry closed ventilated premise with temperature range from +41 °F to +104 °F and relative humidity up to 70 %.
- Storage environment must not contain aggressive vapors and chemical mixtures provoking corrosion, insulation, and sealing deformation.
- Use suitable hoist machinery for handling and storage operations to prevent possible damage to the unit.
- Follow the handling requirements applicable for the particular type of cargo.
- The unit can be carried in the original packaging by any mode of transport provided proper protection against precipitation and mechanical damage. The unit must be transported only in the working position.
- Avoid sharp blows, scratches, or rough handling during loading and unloading.
- Prior to the initial power-up after transportation at low temperatures, allow the unit to warm up at operating temperature for at least 3-4 hours.

MANUFACTURER'S WARRANTY

Production meets standard operating requirements in the USA and Canada.

Vents US warrants to the original purchaser of the unit that it will be free from defects in materials or workmanship for a period of 24 months from the date of original purchase. The Vents US warrants to the original purchaser of the unit that the integrated control unit will be free from defects in materials and workmanship for a period of 24 months from the date of original purchase.

THERE ARE NO OTHER WARRANTIES, EXPRESS OR IMPLIED, INCLUDING, BUT NOT LIMITED TO, IMPLIED WARRANTIES OF MERCHANTABILITY OR FITNESS FOR A PARTICULAR PURPOSE.

During the stated warranty period, Vents US will, at its option, repair or replace, without charge, any product or part which is found to be defective under normal use and service. This warranty does not cover (a) normal maintenance and normal service or (b) any products or parts which have been subject to misuse, negligence, accident, improper maintenance or repair (other than by Vents US), faulty installation or installation contrary to recommended installation instructions. Labor to remove and replace products is not covered. The duration of any implied warranty is limited to the time period specified for the express warranty. Some states do not allow limitations on how long an implied warranty lasts, so the above limitation may not apply to you.

VENTS US OBLIGATION TO REPAIR OR REPLACE, AT VENTS US OPTION, SHALL BE THE PURCHASER'S SOLE AND EXCLUSIVE REMEDY UNDER THIS WARRANTY. VENTS US SHALL NOT BE LIABLE FOR INCIDENTAL, CONSEQUENTIAL OR SPECIAL DAMAGES ARISING OUT OF OR IN CONNECTION WITH PRODUCT USE OR PERFORMANCE.

Some states do not allow the exclusion or limitations of incidental or consequential damages, so the above limitation or exclusion may not apply to you. This warranty gives you specific legal rights, and you may also have other rights which vary from state to state. This warranty supersedes all prior warranties. If proof of sales date is absent, warranty period is calculated from the production date. The unit can be exchanged at the following address:

Vents-US
400 Murray Road, Cincinnati, OH 45217, USA
Tel: 1-888-640-0925, 513-583-5786, Fax: 513-268-4597
E-mail: support@ventsus.com
www.vents-us.com

Please follow guidelines in this manual for product problem-free operation.



FOLLOWING THE REGULATIONS STIPULATED HEREIN WILL ENSURE A LONG AND TROUBLE-FREE OPERATION OF THE UNIT.



USER'S WARRANTY CLAIMS SHALL BE SUBJECT TO REVIEW ONLY UPON PRESENTATION OF THE UNIT, THE PAYMENT DOCUMENT AND THE USER'S MANUAL WITH THE PURCHASE DATE STAMP.

CERTIFICATE OF ACCEPTANCE

Unit Type	Single-room heat recovery air handling unit
Model	
Serial Number	
Manufacture Date	
Quality Inspector's Stamp	

SELLER INFORMATION

Seller	
Address	
Phone Number	
E-mail	
Purchase Date	
This is to certify acceptance of the complete unit delivery with the user's manual. The warranty terms are acknowledged and accepted.	
Customer's Signature	

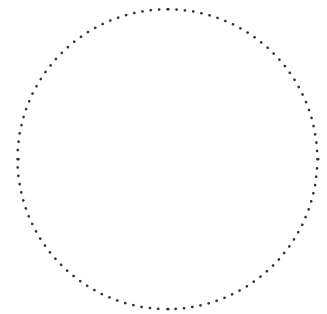

Seller's Stamp

INSTALLATION CERTIFICATE

The unit _____ is installed pursuant to the requirements stated in the present user's manual.	
Company name	
Address	
Phone Number	
Installation Technician's Full Name	
Installation Date:	Signature:
The unit has been installed in accordance with the provisions of all the applicable local and national construction, electrical and technical codes and standards. The unit operates normally as intended by the manufacturer.	
Signature:	

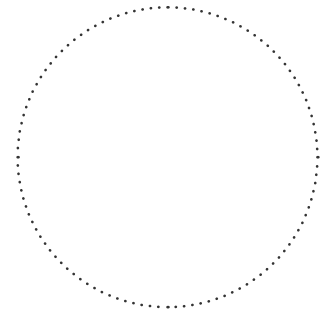

Installation Stamp

WARRANTY CARD

Unit Type	Single-room heat recovery air handling unit
Model	
Serial Number	
Manufacture Date	
Purchase Date	
Warranty Period	
Seller	

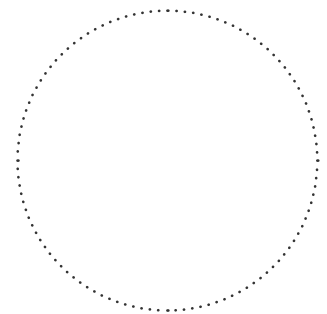

Seller's Stamp

