

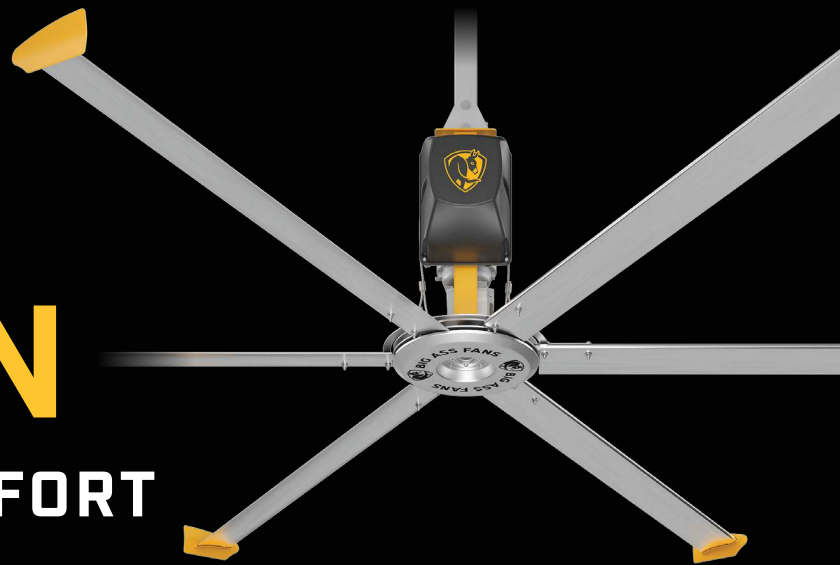

BIG ASS FANS

SHOPFAN

PLUG AND PLAY COMFORT



SERIOUS AIR. SIMPLE SETUP.

ShopFan isn't just easy—it's effortless. Pre-wired and plug-in ready, this DIY-friendly powerhouse installs fast and delivers big air to garages, workshops, and gyms. ShopFan was built for hardworking spaces that need premium airflow at a practical price. Marked with official Big Ass Fans branding, it brings a bold look that stands for quality and performance in every spin. No fluff, no fuss—just serious airflow without the complications.

BENEFITS

- Improves energy efficiency
- Variable speed operation
- Redundant, industry-leading safety systems
- Fully wired and factory tested
- Branded hub and VFD cover
- 1 year warranty



KEY FEATURES

- 100–120V with 3-prong plug
- Mounts to I-beams, purlins, bar joists, and solid beams
- Six aluminum airfoils with winglets
- 14' diameter
- Sealed helical gearbox and industrial motor



FOR MORE INFORMATION

Visit bigassfans.com/contact-us or call **877.BIG.FANS** to learn how ShopFan can transform your space.



BIG ASS FANS

SHOPFAN

TECHNICAL SPECIFICATIONS

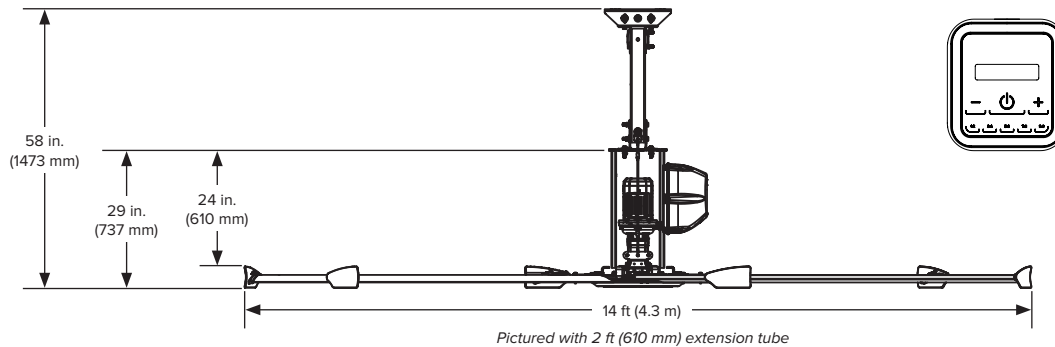
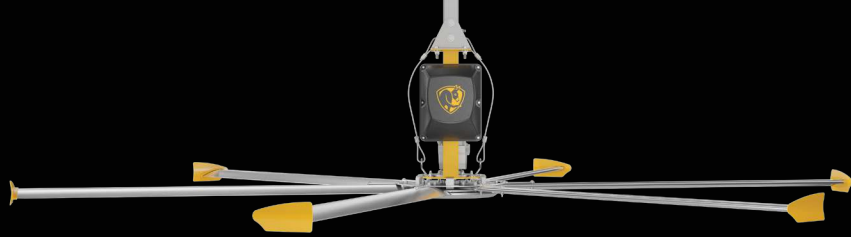

Wired Standard Control
 Height: 4.86 in. (123 mm)
 Width: 4.54 in. (115 mm)
 Depth: 1.3 in. (29 mm)

Technical Specifications

Diameter	Max Weight ¹	Max Speed	Input Power and Required Breaker	Motor Horsepower	Airfoil Clearances ²	Max Operating Temperature	Sound at Max Speed ³
14 ft (4.3 m)	172 lb (78 kg)	70.4 RPM	100–120 VAC, 50/60 Hz, 1 Φ, 15 A	1.0 hp (0.75 kW)	2 ft (0.6 m) on sides 5 ft (1.5 m) below ceiling	104°F (40°C)	< 55 dBA

Construction Features

Airfoils	Motor and Onboard VFD	Mounting	Multi-Point Safety ⁴	Colors
Six patented Powerfoil airfoils (mill finish) Powerfoil winglets eliminate wind noise (BAF yellow)	Industrial-grade motor and gearbox feature inline helical-cut gears for efficient, durable, and reliable operation; lubricated for life with synthetic oil Onboard, pre-wired NEMA 4X VFD housed in spacious ABS/PVC-based enclosure with built-in heatsink 15 ft (4.6 m) VFD power cord plugs into standard electrical outlet	Standard upper mount installs to I-beams and bar joists 2 ft (0.6 m) extension tube Optional kits allow for mounting to solid beams and purlins	Double safety cable system, airfoil retainers, hub safety clips, Grade 8 hardware, and fire relay	Silver and Yellow

Wired Standard Control

Construction	Controls
Made from durable UV-resistant materials Rated IP55 Intuitive touchscreen interface	On/Off and variable speed control Password protection Powered by fan drive

Wired Standard Control



¹ Weight does not include mount or extension tube.
² Measure the distance from the tip of the winglet to the ceiling or major obstruction.
³ Fans are sound tested at maximum speed in a laboratory environment. Actual results in field conditions may vary due to sound reflecting surfaces and environmental conditions.
⁴ The fire relay must be wired during install if required by local code.



Lead times may vary.
 See full warranty for coverage information.



USA
 BIGASSFANS.COM
 877.244.3267

CANADA
 BIGASSFANS.COM
 844.924.4277

AUSTRALIA
 BIGASSFANS.COM/AU
 1300.244.277

SINGAPORE
 BIGASSFANS.COM/SG
 65.6709.8500